



三合微科股份有限公司  
SAMHOP Microelectronics Corp.

SM7183  
ECHO

## GENERAL DESCRIPTIONS

SM7183 is an Audio Echo Processor using CMOS Technology. It has built-in AD/DA and 30KBits SRAM for time delay. Three sample rate selection and eight delay time selection. Many combination to fit your applications.

## FEATURES

- \* Built-in adjustable OSC.
- \* Built-in power on reset circuit.
- \* Built-in 30KBits SRAM for delay control.
- \* Adjustable delay time setting:  
Echo Mode: 20.5ms ~ 163.8ms  
Surround Mode: 4.1ms ~ 41.0ms  
(Based on 6MHz OSC)
- \* Direct control & Micro-processor control interface.
- \* Auto muting during power up and change mode.

## APPLICATIONS

- \* VCD
- \* Karaoke
- \* TV
- \* Audio System
- \* Car Stereo

## PIN ASSIGNMENT

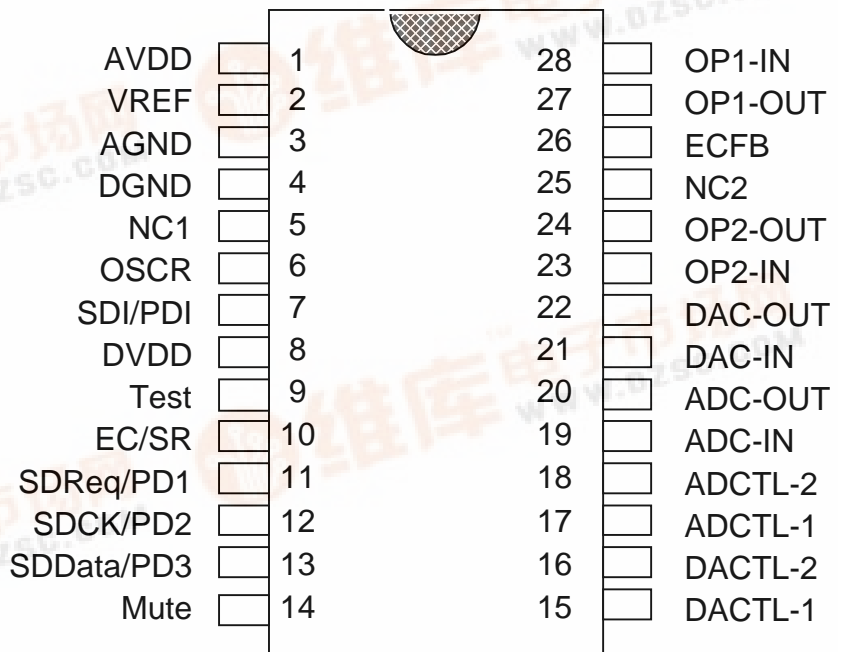



## PIN DESCRIPTION

Pin No.	Pin Name	I/O	Function
1	AVDD	Power	Analog positive power supply
2	VREF	AI/O	Analog reference voltage
3	AGND	Power	Analog negative power supply
4	DGND	Power	Digital negative power supply
5	NC1		No connection
6	OSCR	OSC	Add resistor to modify internal OSC
7	SDI/PDI	IN	Micro processor Serial interface or Parallel input selection
8	DVDD	Power	Digital positive power supply
9	Test	IN	Test mode input
10	EC/SR	IN	Echo or Surround mode selection
11	SDReq/PD1	IN	Micro processor Serial interface or Parallel input
12	SDCK/PD2	IN	
13	SDData/PD3	IN	
14	Mute	IN	Mute control
15	DACTL-1	AIN	DAC control pin1
16	DACTL-2	AIN	DAC control pin2
17	ADCTL-1	AIN	ADC control pin1
18	ADCTL-2	AIN	ADC control pin2
19	ADC-IN	AIN	ADC OP input
20	ADC-OUT	AOUT	ADC OP output
21	DAC-IN	AIN	DAC OP input
22	DAC-OUT	AOUT	DAC OP output
23	OP2-IN	AIN	OP2 input
24	OP2-OUT	AOUT	OP2 output
25	NC2		No connection
26	ECFB	AOUT	Echo feed back pin
27	OP1-OUT	AIN	OP1 output
28	OP1-IN	AOUT	OP2 input



BLOCK DIAGRAM

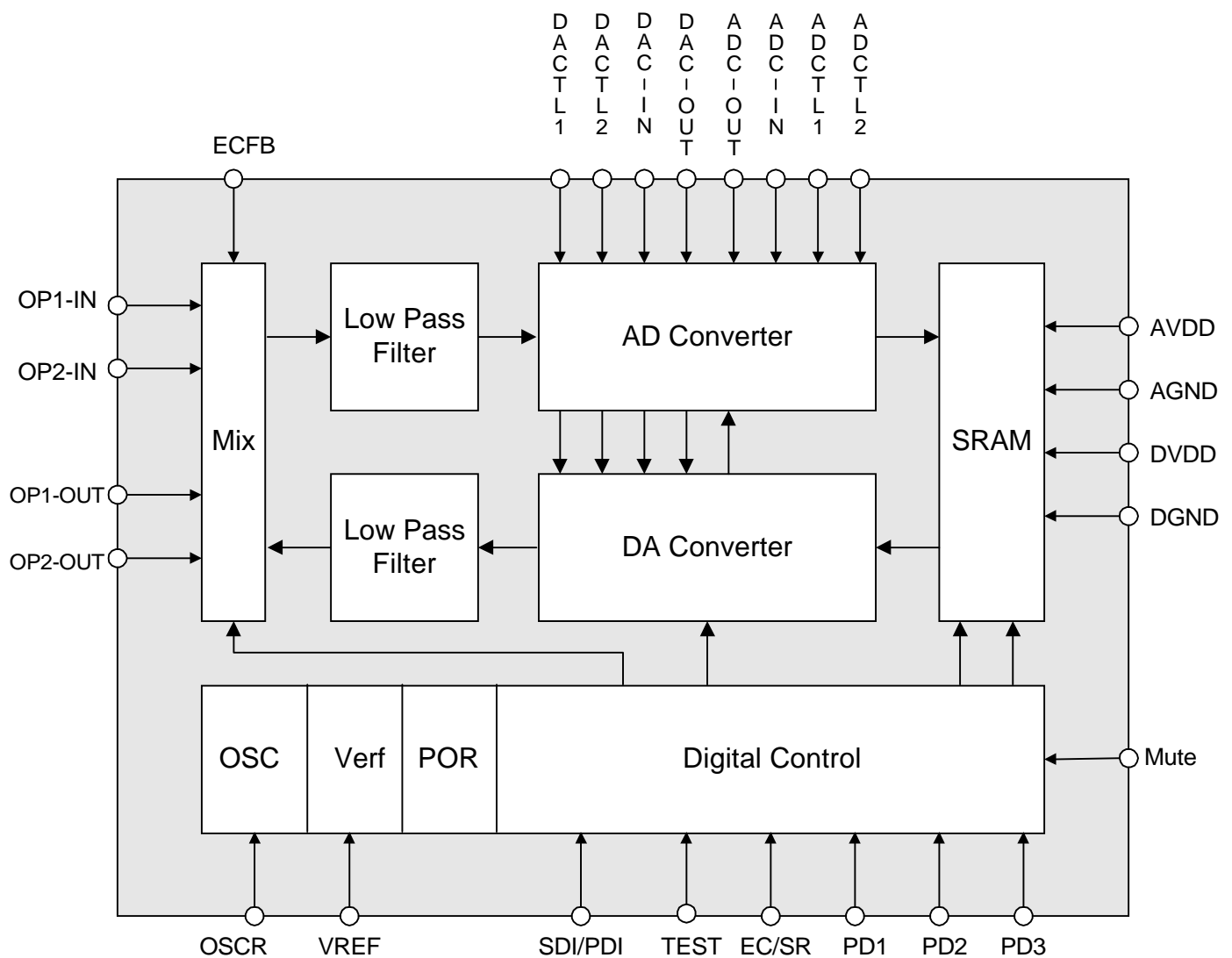



## FUNCTION DESCRIPTIONS:

Internal Control Register :

Serial Interface:

There is one register for SM7183's mode selection, mute control and delay time setting. This 5-bits register can only be access by tie SDI/PDI pin to VDD.

When SDI/PDI is tie to VDD, the SM7183's state is control by this internal 5 Bits register. These bits are Mode for select Echo/Surround, Mute, Delay 1, Delay 2, Delay 3 for control delay time.

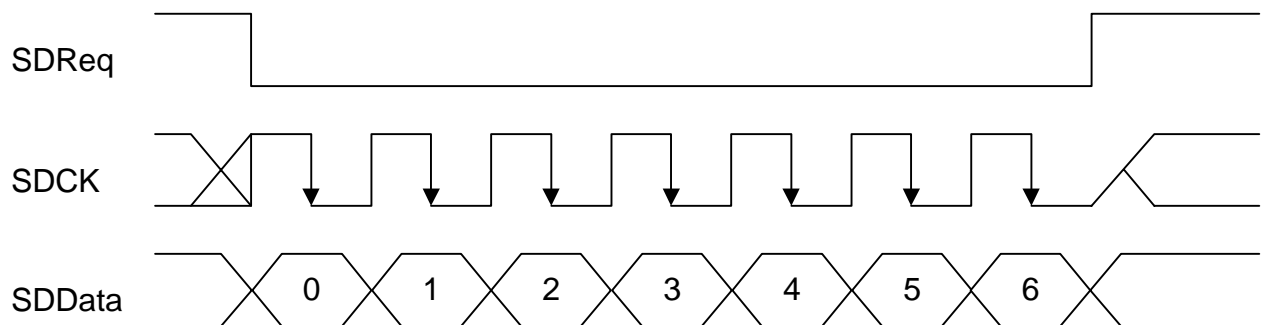

When SDREQ is low then SM7183 is ready for received data from SDDATA. SM7183 will latch the SDDATA using the SDCK's negative edge.

- BIT 0,1 are unused data.
- BIT 2 is Mode as EC/SR
- BIT 3 is Mute as MUTE
- BIT 4 is Delay 1 as PD1
- BIT 5 is Delay 2 as PD2
- BIT 6 is Delay 3 as PD3

Parallel Mode:

There are corresponding pin for the 5 bits when SDI/PDI is tie to VSS, the SM7183's state is control by external pins, like MUTE, Echo/Surround, PD1, PD2, PD3. The 5-Bits register can be access by SDReq, SDCK, SDData pin follow the following timing diagram.



### Echo Mode & Surround Mode

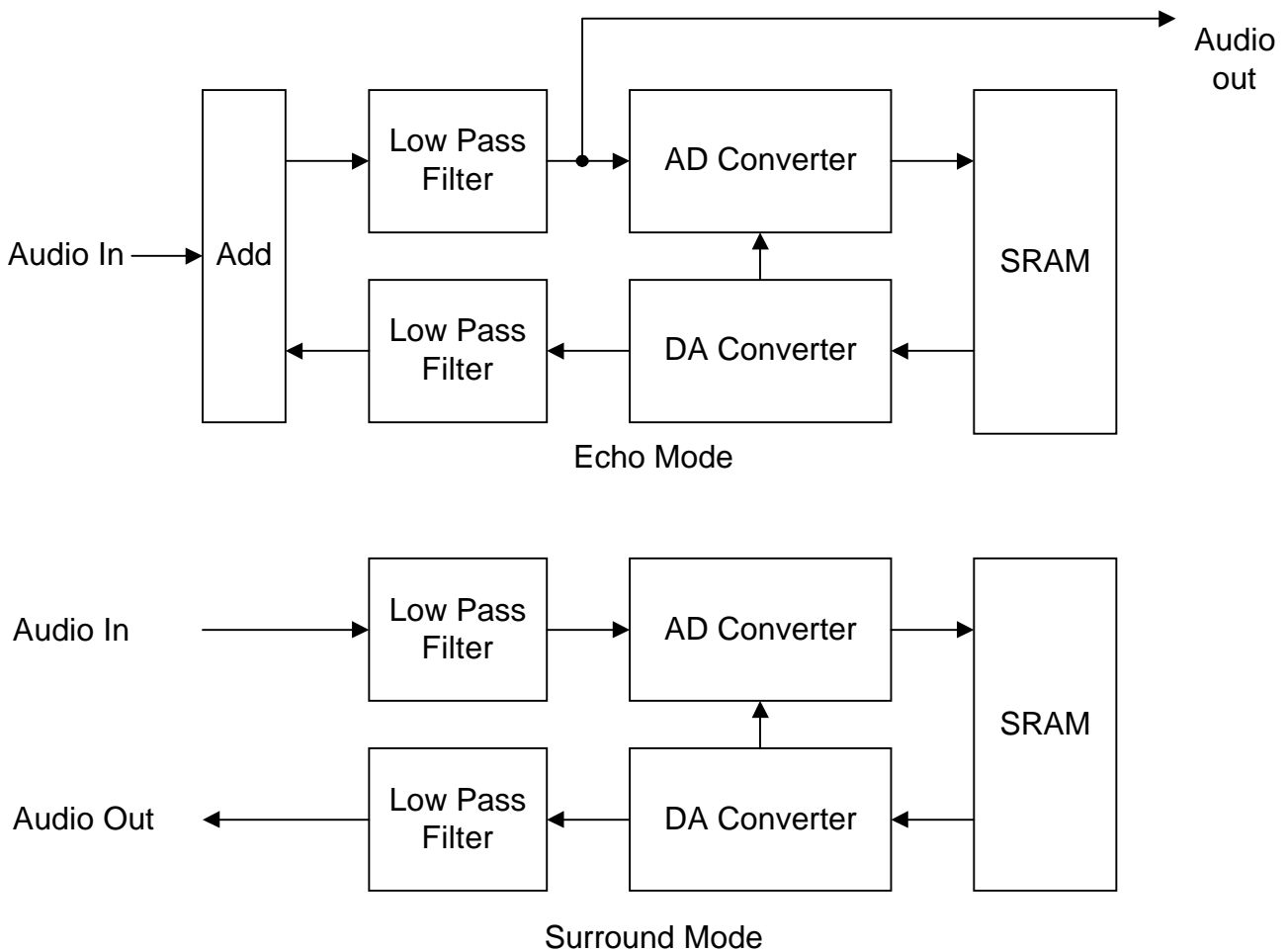

When EC/SR pin is tie to VDD then SM7183 is set to Echo Mode. When EC/SR pin is tie to GND then SM7183 is set to Surround Mode. The only difference between echo mode and surround mode are there is no feed back & add path inside the SM7183. And the delay time is shorter for surround mode then echo mode. But surround mode provide higher sampling rate and better sound quality then echo mode.

### MUTE CONTROL

After power up the SM7183 will turn off its output for 350 ms. Any change of the EC/SR, PD1~2 pin and internal register, SM7183 will mute and turn off its output for 350 ms.



**DELAY TIME TABLE**

Surround Mode	PD1	PD2	PD3	Sample Rate	Delay Time
0	0	0	0	750KHZ	4.1ms
0	1	1	0	750KHZ	10.2ms
0	1	0	0	750KHZ	14.3ms
0	0	1	0	750KHZ	20.5ms
0	1	0	1	750KHZ	24.6ms
0	0	0	1	750KHZ	30.7ms
0	0	1	1	750KHZ	34.8ms
0	1	1	1	750KHZ	41.0ms

Echo Mode	PD1	PD2	PD3	Sample Rate	Delay Time
1	0	0	0	375KHZ	20.5ms
1	1	1	0	375KHZ	41.0ms
1	1	0	0	375KHZ	61.4ms
1	0	1	0	375KHZ	81.9ms
1	1	0	1	187.5KHZ	98.3ms
1	0	0	1	187.5KHZ	122.9ms
1	0	1	1	187.5KHZ	139.3ms
1	1	1	1	187.5KHZ	163.8ms

NOTE: All the value are based on internal OSC is 6MHz



## AC CHARACTERISTICS

(  $V_{cc} = 5.0V$ ,  $f_{in} = 1KHz$ ,  $V_i = 100mV_{rms}$ ,  $f_{ck} = 6MHz$ ,  $T_a = 25^{\circ}C$ , unless otherwise noted )

Symbol	Parameter	Test Condition	Min.	Typ.	Max.	Unit	
I <sub>cco</sub>	Supply current			60	100	mA	
G <sub>v</sub>	Voltage gain	RL = 47K		-0.5	2.5	dB	
V <sub>omax</sub>	Maximum output voltage	THD = 10%	0.7	1.2		V <sub>rms</sub>	
THD	Output distortion	30KHz L.P.F.	Echo mode		1.5	3.0	%
			Surround mode		0.3	1.0	%
No	Output noise voltage	DIN Audio	Echo mode		-85	-60	dBV
			Surround mode		-90	-70	dBV
PSRR	Power supply rejection ratio	$\Delta V_{cc} = -20dBV$ $f = 100Hz$		-40	-25	dB	
T <sub>mute</sub>	Mute time	Echo mode	515	520	525	msec	
		Surround mode	122	127	132	msec	

## DC CHARACTERISTICS

Symbol	Parameter	Limits			Unit
		Min	Typ	Max	
V <sub>cc</sub>	Supply voltage	4.5	5	5.5	V
I <sub>cc</sub>	Supply current		60	100	mA
V <sub>IH</sub>	"H" input voltage	3V			V
V <sub>IL</sub>	"L" input voltage			1.5V	V



**ABSOLUTE MAXIMUM RATINGS**

( Ta = 25 , unless otherwise noted )

Symbol	Description	Limits	Unit
Vcc	Supply voltage	6.5	V
Icc	Supply current	100	mA
Pd	Power dissipation	1.7	W
Topr	Operation temperature	-20 ~ 75	
Tstg	Storage temperature	-25 ~ 125	





ECHO MODE APPLICATION CIRCUIT

Echo Mode

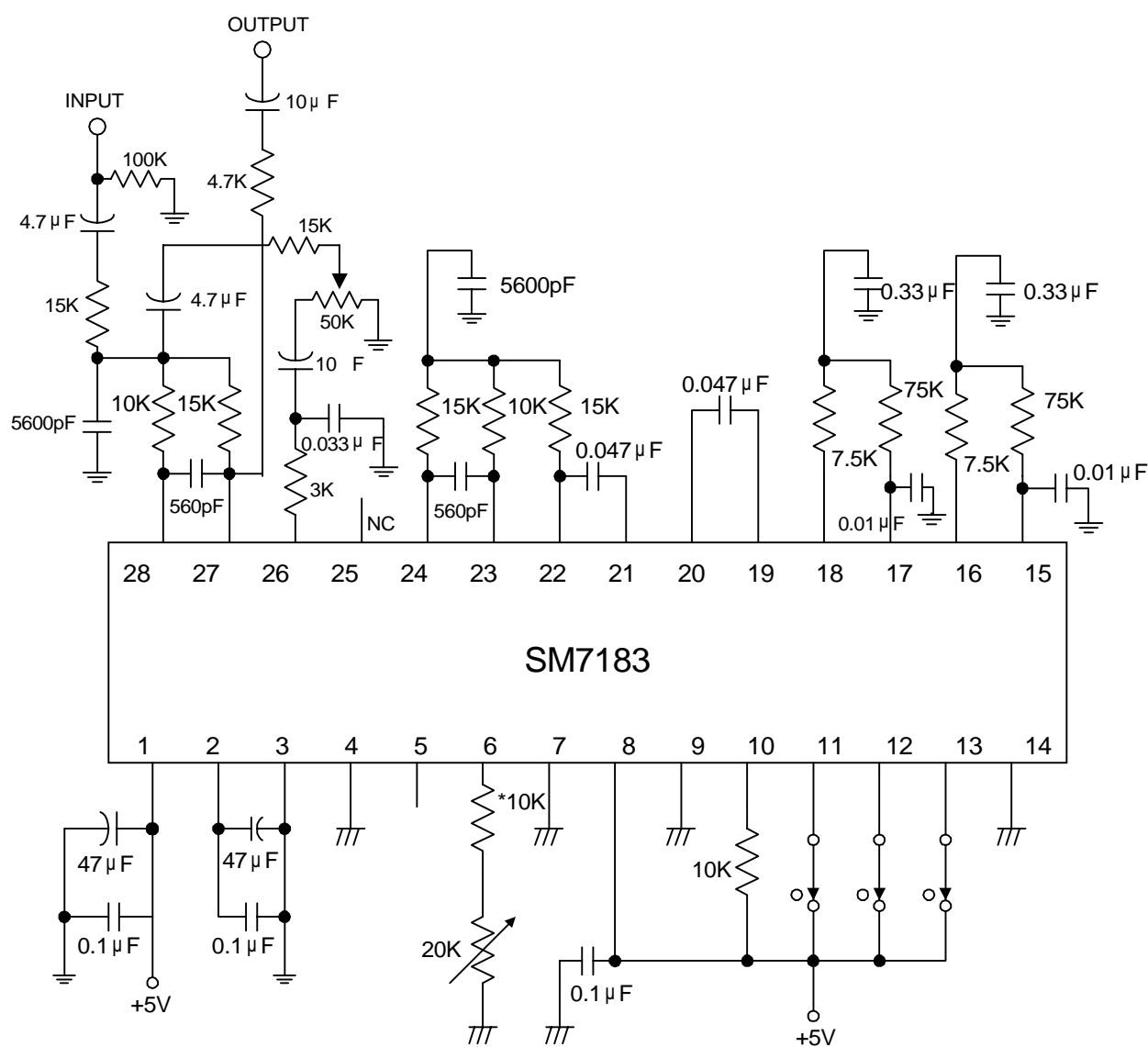

1. Pin 6 R is approximate 15K~25k .
2.  $\perp$  Represent Analog Ground.
3.  $\text{///}$  Represent Digital Ground.



MIC PRE-AMP CIRCUIT

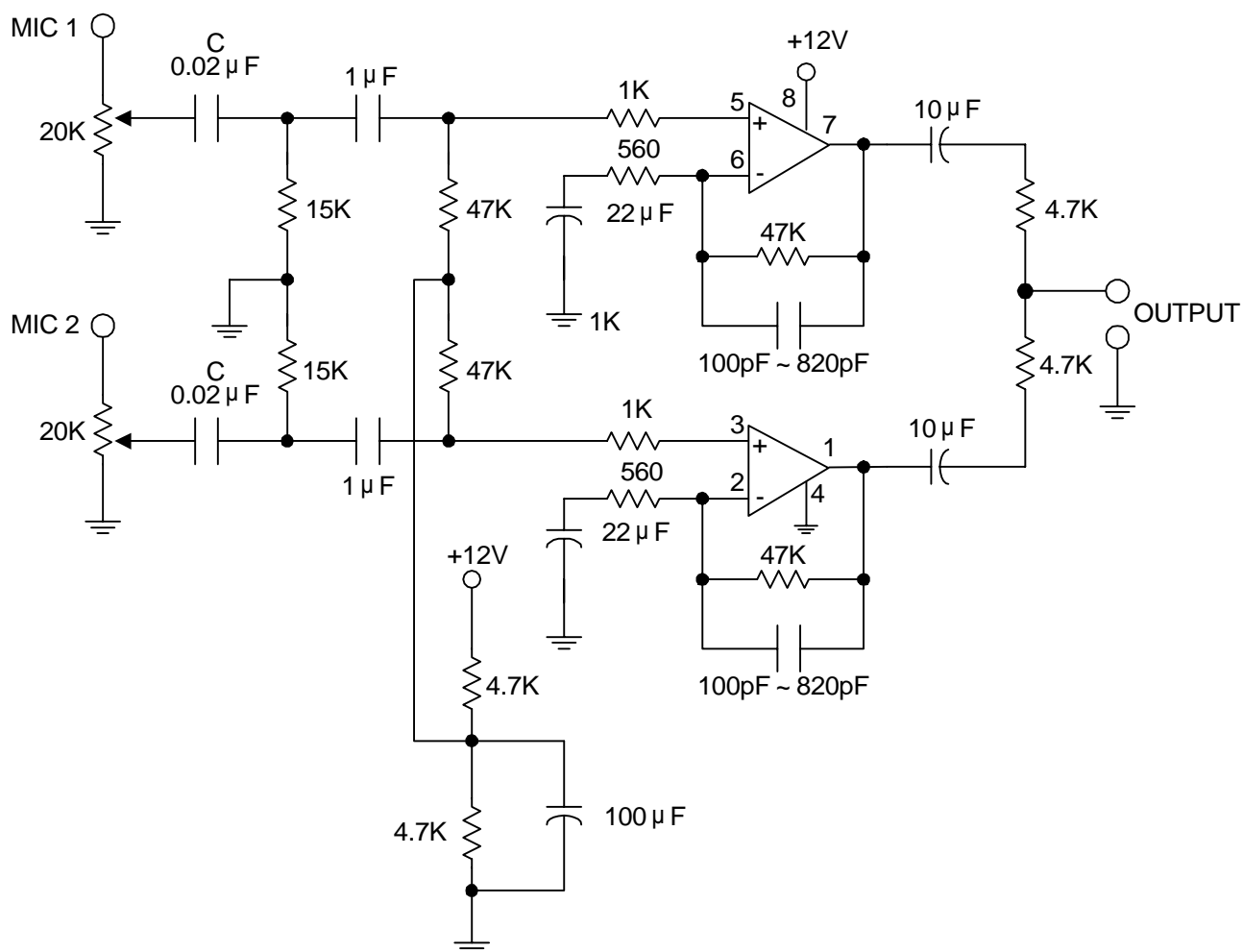



SURROUND MODE APPLICATION CIRCUIT

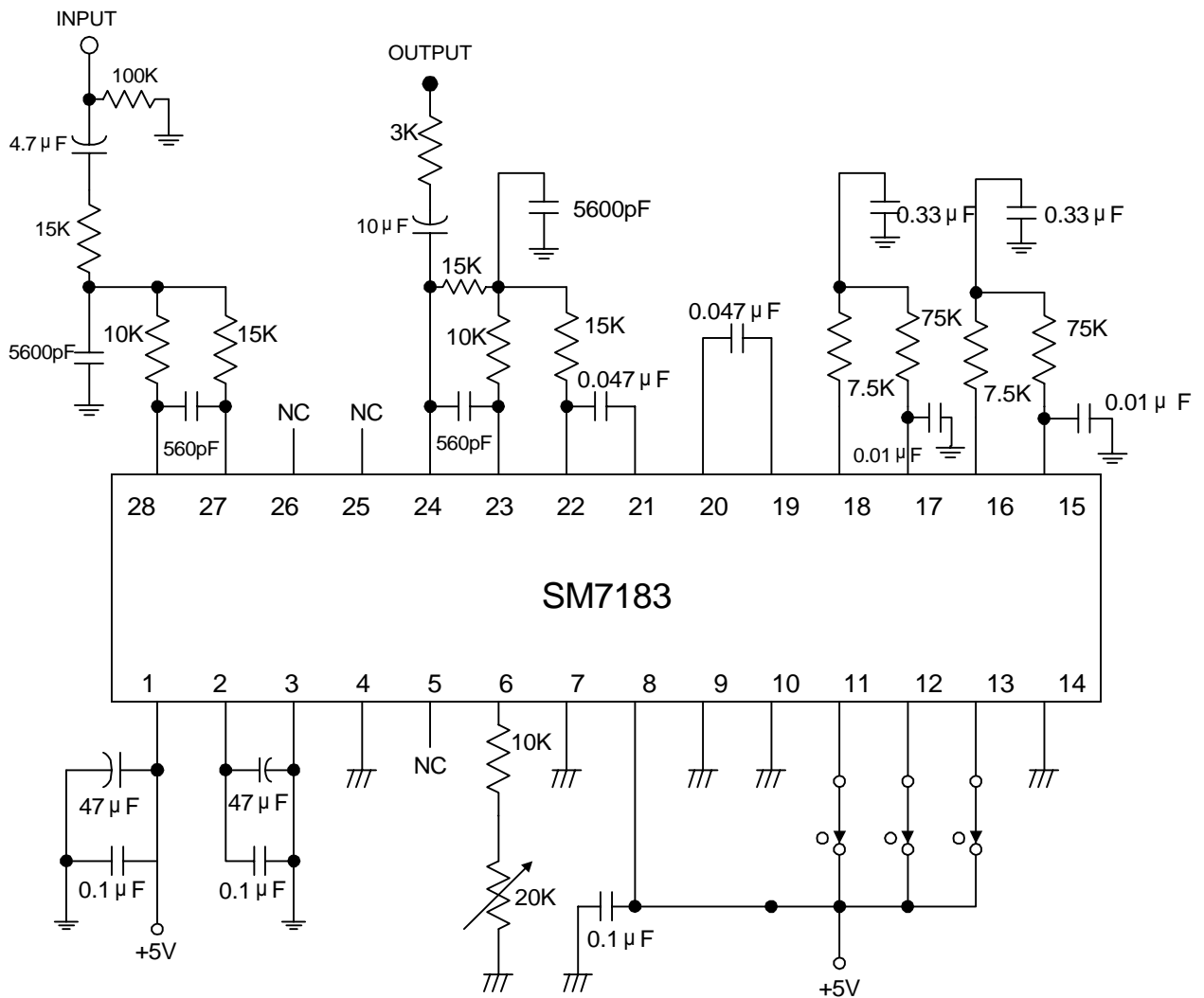



MUTE APPLICATION CIRCUIT

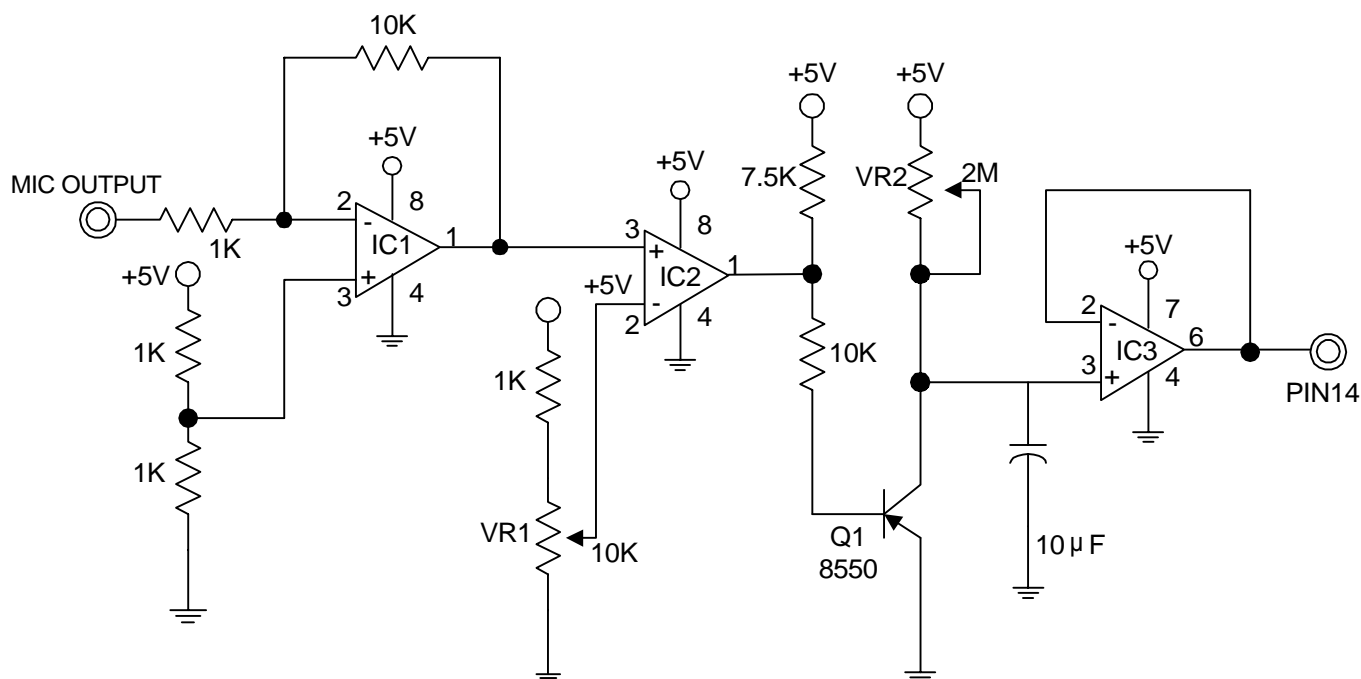

VR2	Time
1.46M	11.0S
1.2M	9.0S
1.0M	7.6S
0.8M	6.0S
0.6M	4.5S
0.4M	3.0S