



SMA427A

50 Ω / 50 Ω Low Noise Amplifier

PRELIMINARY DATA

- CASCADABLE 50 ohm-GAIN BLOCK
- UNCONDITIONALLY STABLE
- GAIN $|S_{21}|^2 = 17$ dB at 1.8 GHz
- $IP_{3out} = +7.4$ dBm at 1.575 GHz ($V_D = 3$ V, $I_D = 9.5$ mA)
- NOISE FIGURE $NF = 2.2$ dB at 1.8 GHz
- TYPICAL DEVICE VOLTAGE $V_D = 2$ V to 5 V
- ULTRA MINIATURE SOT323-4L PACKAGE (LEAD FREE)

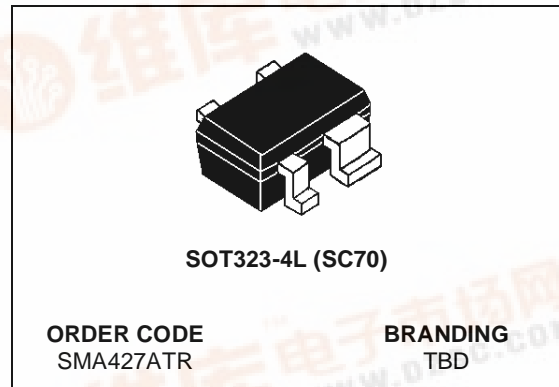

APPLICATIONS

LNA FOR 1-2 GHz APPLICATIONS (GPS, Cellular..)

DESCRIPTION

SMA427A is a product of the SMA Family (Silicon MMIC Amplifiers). Housed in the ultra miniature 4-lead SC-70 (SOT323-4L LEAD FREE) surface mount plastic package, it embeds the state of the art Silicon ST technology. The amplifier application shows excellent RF performance using only two external component in the 1000-2000MHz frequency range.

BLOCK DIAGRAM

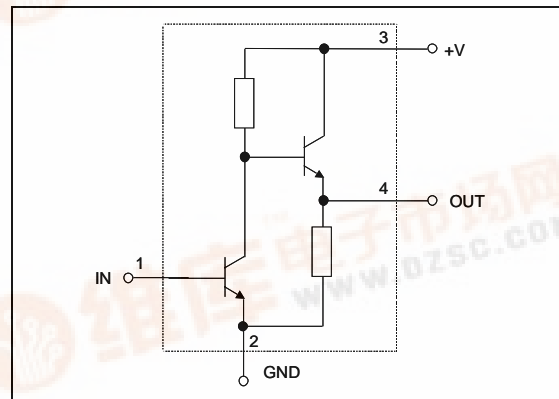

ABSOLUTE MAXIMUM RATINGS

Symbol	Parameter	Value	Unit
V_D	Device Voltage	6	V
I_D	Device Current	27	mA
P_{tot}	Total dissipation, $T_s = 120$ °C	TBD	mW
P_{RFIn}	RF Input Power	-10	dBm
T_{amb}	Ambient Temperature	-65 to +150	°C
T_{stg}	Storage temperature	-65 to +150	°C
T_j	Max. operating junction temperature	150	°C

THERMAL RESISTANCE

R_{thjs}	Thermal Resistance Junction soldering point	TBD	°C/W
------------	---	-----	------

SMA427A

ELECTRICAL CHARACTERISTICS

(Ta = +25°C, VD = 3V, Zo = 50Ω, tested in circuit shown in Appl.1, unless otherwise specified)

Symbol	Parameter	Test Conditions	Min.	Typ.	Max.	Unit
Id	Supply Current			9.5		mA
$ S_{21} ^2$	Insertion power gain	f = 1 GHz f = 1.575 GHz f = 1.8 GHz		22 18 17		dB
S12	Reverse Isolation	f = 1 GHz f = 1.575 GHz f = 1.8 GHz		27 25 20		dB
NF	Noise Figure	f = 1 GHz f = 1.575 GHz f = 1.8 GHz		1.8 2 2.2		dB
IP _{3out}	Intercept point at output	f = 1.575 GHz		7.4		dBm
RLin	Input Return Loss	f = 1 GHz f = 1.575 GHz f = 1.8 GHz		>12 >12 >12		dB
RLout	Output Return Loss	f = 1 GHz f = 1.575 GHz f = 1.8 GHz		>12 >12 >12		dB

PIN CONNECTION

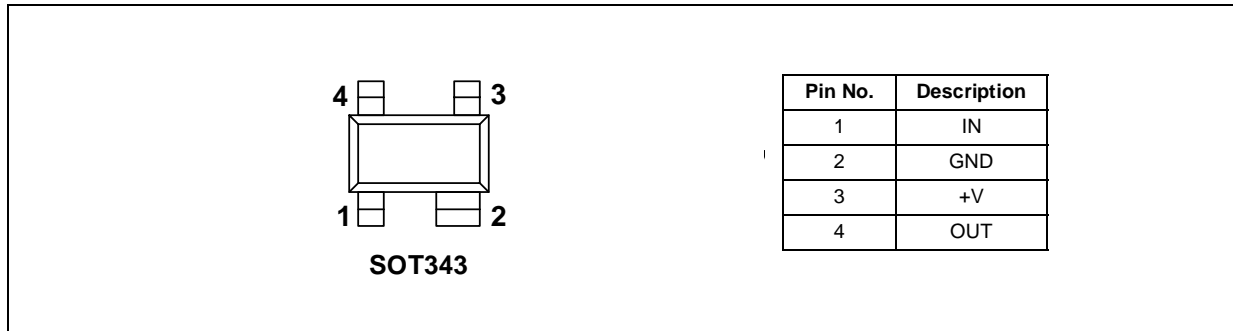

Typical configuration

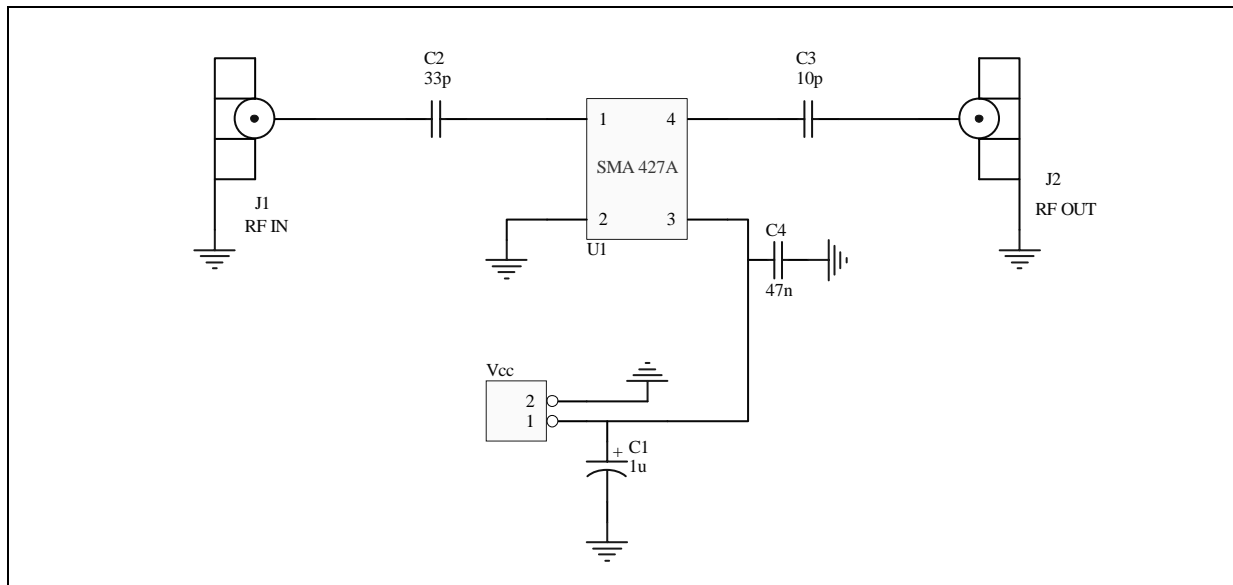

S-Parameters

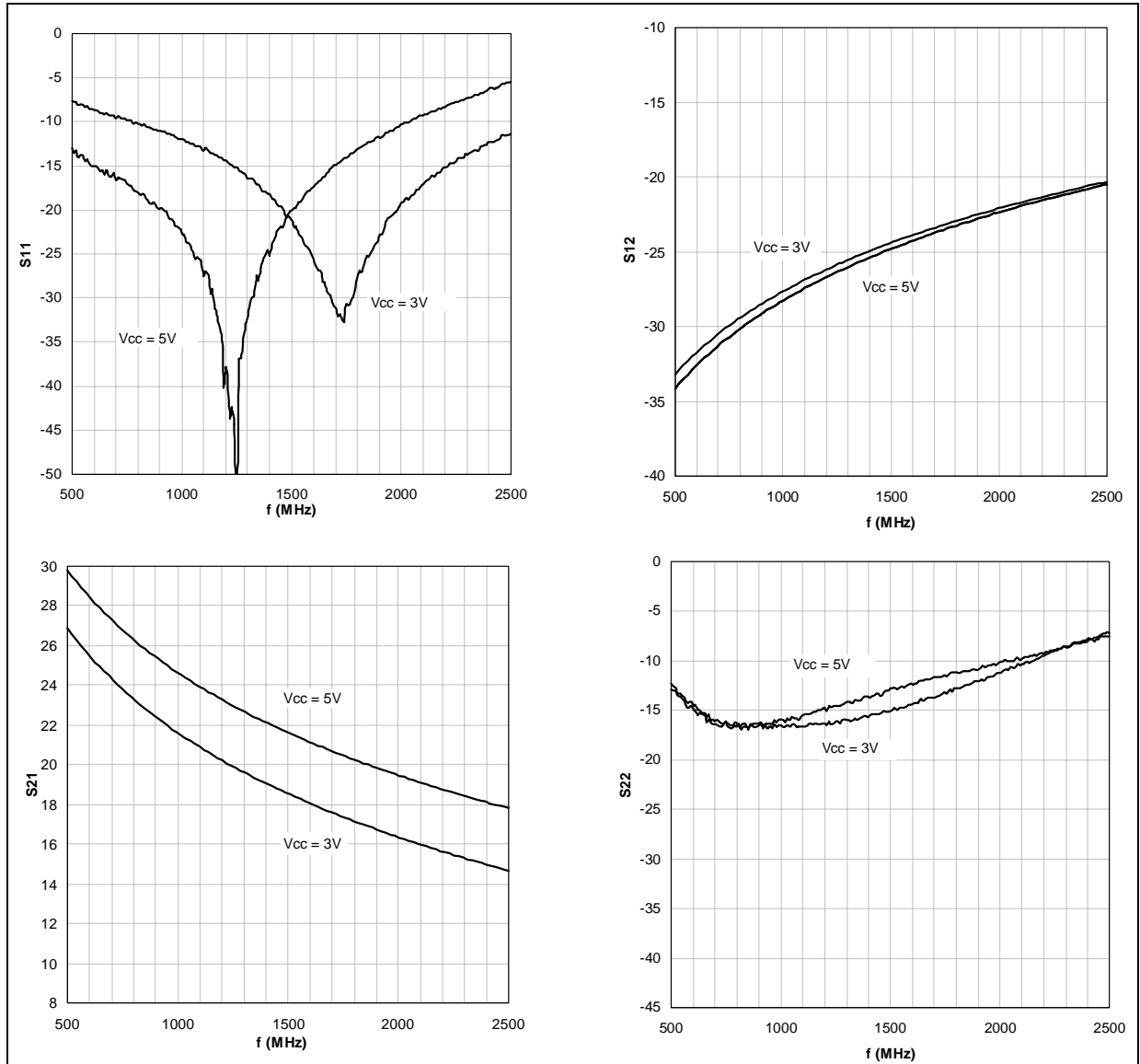

Noise Figure vs. Frequency

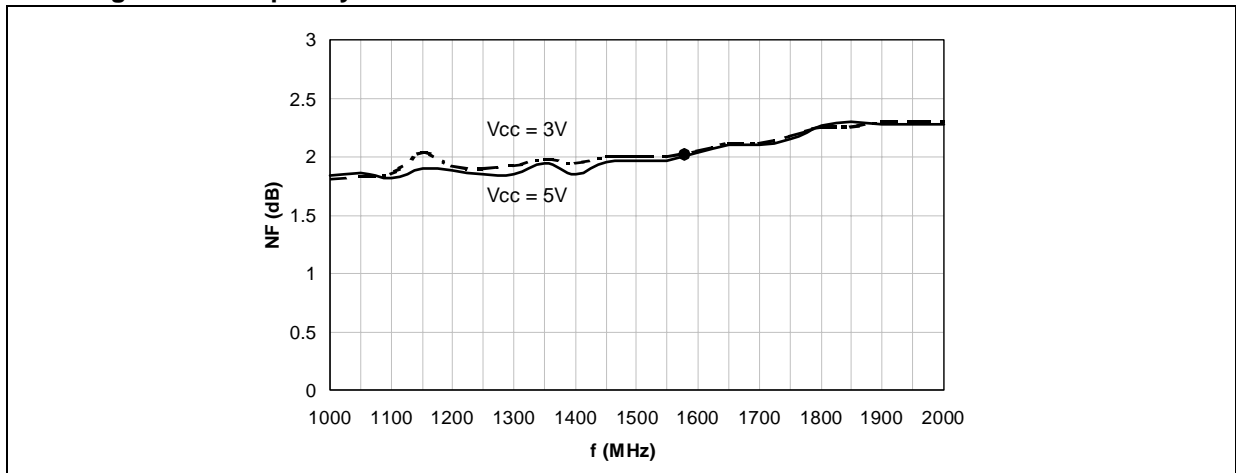

SMA427A

TAPE & REEL DIMENSIONS

	mm		
	MIN.	TYP.	MAX
A	178.5	179	179.5
C	12.8	13.0	13.5
D	20.2		
N	54.5	55	55.5
T			14.4
Ao		2.25	
Bo		2.7	
Ko		1.2	
Po	3.8 (cumulative 10 Po)	4.0	4.2 (cumulative 10 Po)
P		4.0	

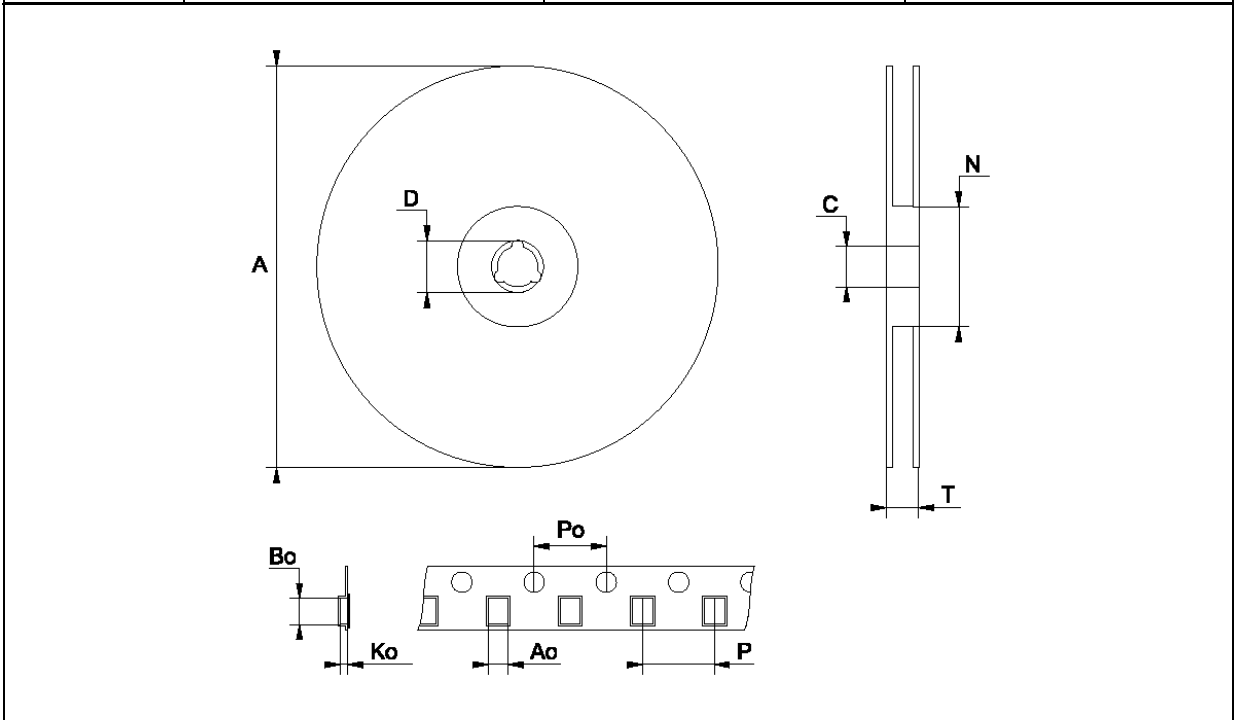

DEVICE ORIENTATION

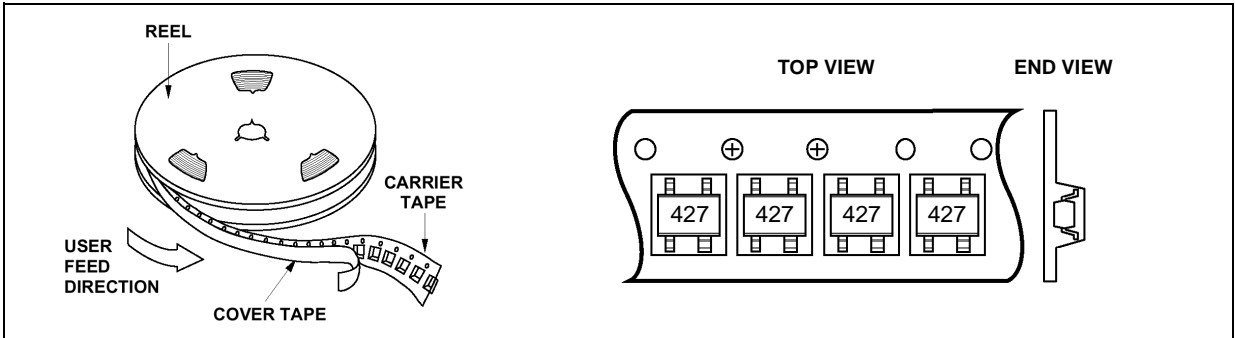

PACKAGE DIMENSIONS SOT323-4L (SC-70 4 leads)

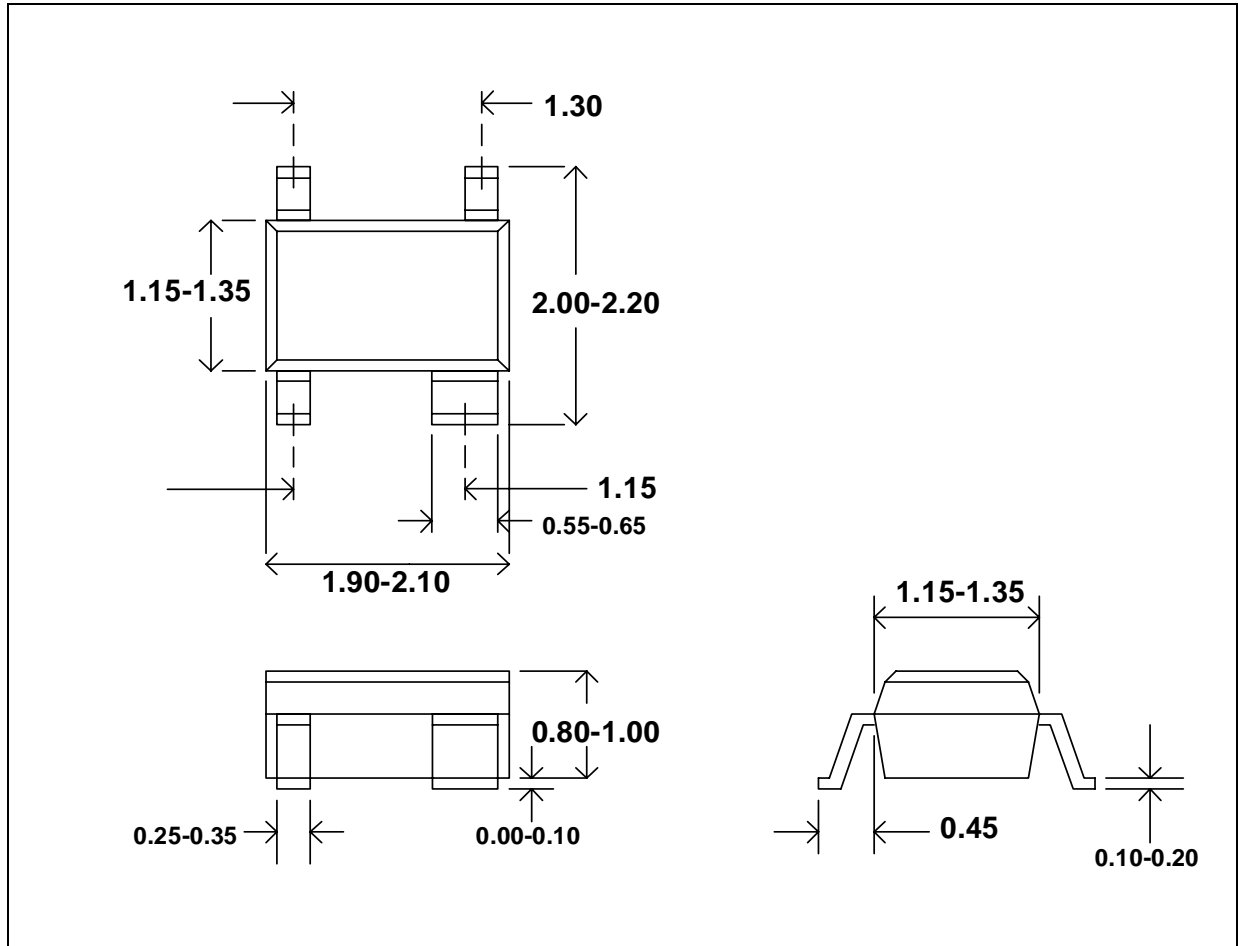

Information furnished is believed to be accurate and reliable. However, STMicroelectronics assumes no responsibility for the consequences of use of such information nor for any infringement of patents or other rights of third parties which may result from its use. No license is granted by implication or otherwise under any patent or patent rights of STMicroelectronics. Specifications mentioned in this publication are subject to change without notice. This publication supersedes and replaces all information previously supplied. STMicroelectronics products are not authorized for use as critical components in life support devices or systems without express written approval of STMicroelectronics.

The ST logo is registered trademark of STMicroelectronics
© 2003 STMicroelectronics - All Rights Reserved

All other names are the property of their respective owners.

STMicroelectronics GROUP OF COMPANIES
Australia - Brazil - Canada - China - Finland - France - Germany - Hong Kong - India - Israel - Italy - Japan -
Malaysia - Malta - Morocco - Singapore - Spain - Sweden - Switzerland - United Kingdom - U.S.A.
<http://www.st.com>