

SMA6501**Silicon NPN, PNP Epitaxial Planar****Maximum Ratings**

(Ta=25°C)

Item	Symbol	Ratings		Unit
		NPN	PNP	
Collector-to-Base Voltage	V _{CB0}	100±15	-50	V
Collector-to-Emitter Voltage	V _{CEO}	100±15	-50	V
Emitter-to-Base Voltage	V _{EBO}	6	-6	V
Collector Current	I _C	2	-4	A
Base Current	I _B	0.5	-0.5	A
Total Power Dissipation	P _T	4 (Ta=25°C)		W
		20 (Tc=25°C)		
Storage Temperature	T _{stg}	-40~+150		°C

Electrical Characteristics

(Ta=25°C)

Item	Symbol	Specification		Unit
		NPN	PNP	
Collector Cut-off Current	I _{CB0}	10max (V _{CB} =85V)	-10max (V _{CB} =-50V)	μA
Emitter Cut-off Current	I _{EBO}	5max (V _{EB} =6V)	-10max (V _{EB} =-6V)	mA
Collector-to-Emitter Voltage	V _{CEO}	100±15min (I _C =10mA)	-50min (I _C =-10mA)	V
DC Forward Current Transfer Ratio	h _{FE}	2000min (V _{CE} =4V, I _C =1A)	2000min (V _{CE} =-4V, I _C =-2A)	
Collector-to-Emitter Saturation Voltage	V _{CE(sat)}	1.5max (I _C =1A, I _B =2mA)	-1.5max (I _C =-2A, I _B =-4mA)	V

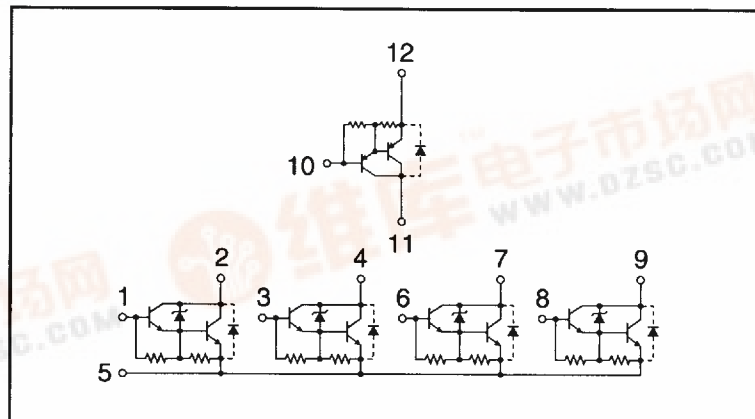
Equivalent Circuit Diagram

Notes on using products

Outline Drawings (Unit:in mm)

STA Family

STA300 Series

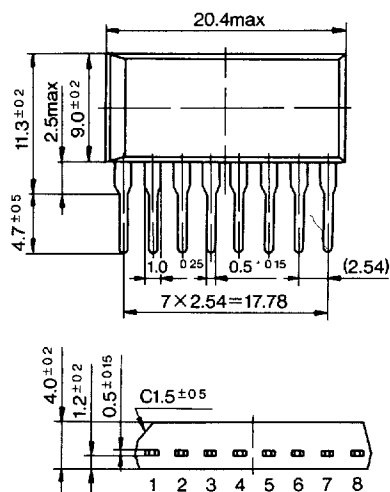

Weight Approx. 2.0g

STA400 Series

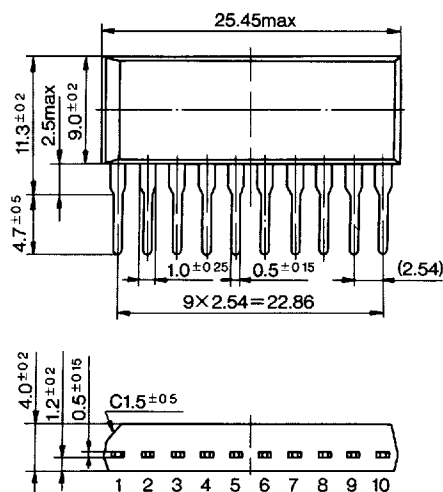

Weight Approx. 2.6g

SMA Family

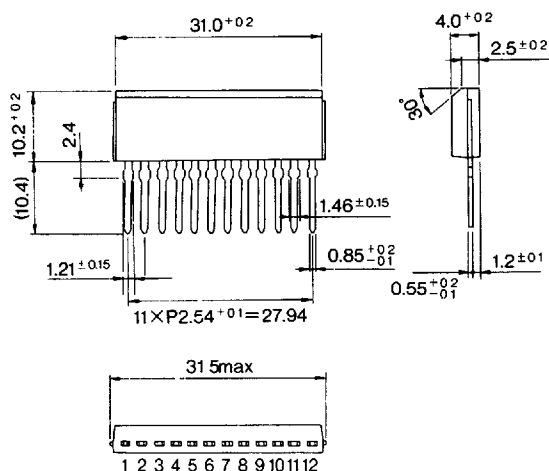

Weight Approx. 4.0g

SLA Family

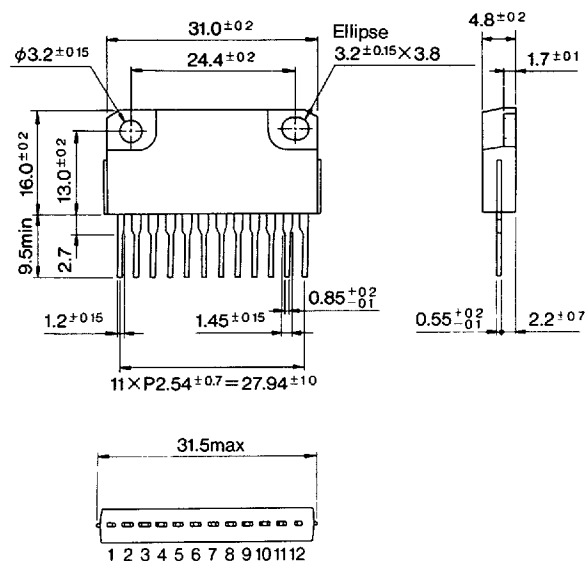

Weight Approx. 6.0g