

- High-Resolution, Solid-State Image Sensor for NTSC B/W TV Applications
- 8-mm Image-Area Diagonal, Compatible With 1/2" Vidicon Optics
- 755 (H) x 242 (V) Active Elements in Image-Sensing Area
- Advanced On-Chip Signal Processing
- Low Dark Current
- Electron-Hole Recombination Antiblooming
- Dynamic Range . . . More Than 70 dB
- High Sensitivity
- High Photoresponse Uniformity
- High Blue Response
- Single-Phase Clocking
- Solid-State Reliability With No Image Burn-in, Residual Imaging, Image Distortion, Image Lag, or Microphonics

DUAL-IN-LINE PACKAGE
(TOP VIEW)

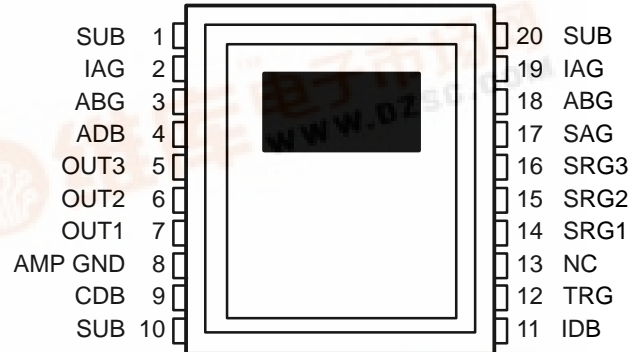

NC – No internal connection

description

The TC245 is a frame-transfer charge-coupled device (CCD) image sensor designed for use in single-chip B/W NTSC TV applications. The device is intended to replace a 1/2-inch vidicon tube in applications requiring small size, high reliability, and low cost.

The image-sensing area of the TC245 is configured into 242 lines with 786 elements in each line. Twenty-nine elements are provided in each line for dark reference. The blooming-protection feature of the sensor is based on recombining excess charge with charge of opposite polarity in the substrate. This antiblooming is activated by supplying clocking pulses to the antiblooming gate, which is an integral part of each image-sensing element. The sensor is designed to operate in an interlace mode, electronically displacing the image-sensing elements in alternate fields by one-half of a vertical line during the charge integration period, effectively increasing the vertical resolution and minimizing aliasing. The device can also be operated as a 755 (H) by 242 (V) noninterlaced sensor with significant reduction in the dark signal.

A gated floating-diffusion detection structure with an automatic reset and voltage reference incorporated on-chip converts charge to signal voltage. The signal is further processed by a low-noise, state-of-the-art correlated clamp-sample-and-hold circuit. A low-noise, two-stage, source-follower amplifier buffers the output and provides high output-drive capability. The image is read out through three outputs, each of which reads out every third image column.

The TC245 is built using TI-proprietary virtual-phase technology, which provides devices with high blue response, low dark signal, good uniformity, and single-phase clocking. The TC245 is characterized for operation from -10°C to 45°C.



This MOS device contains limited built-in gate protection. During storage or handling, the device leads should be shorted together or the device should be placed in conductive foam. In a circuit, unused inputs should always be connected to SUB. Under no circumstances should pin voltages exceed absolute maximum ratings. Avoid shorting OUTn to ADB during operation to prevent damage to the amplifier. The device can also be damaged if the output terminals are reverse-biased and an excessive current is allowed to flow. Specific guidelines for handling devices of this type are contained in the publication *Guidelines for Handling Electrostatic-Discharge-Sensitive (ESDS) Devices and Assemblies* available from Texas Instruments.

TC245 786- × 488-PIXEL CCD IMAGE SENSOR

SOCS019A – DECEMBER 1991

functional block diagram

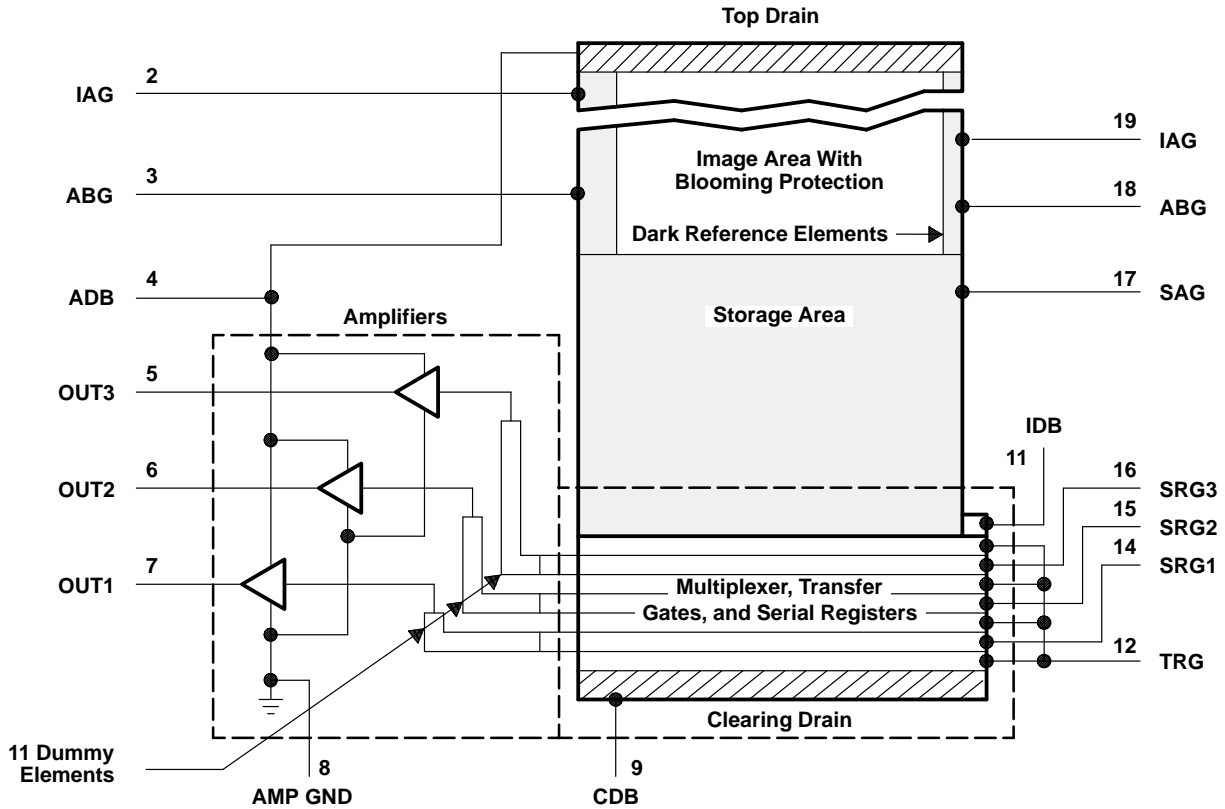

detailed description

The TC245 consists of four basic functional blocks: (1) the image-sensing area, (2) the image-storage area, (3) the multiplexer block with serial registers and transfer gates, and (4) the low-noise signal-processing amplifier block with charge-detection nodes. The location of each of these blocks is identified in the functional block diagram.

TC245 786- × 488-PIXEL CCD IMAGE SENSOR

SOCS019A – DECEMBER 1991

sensor topology diagram

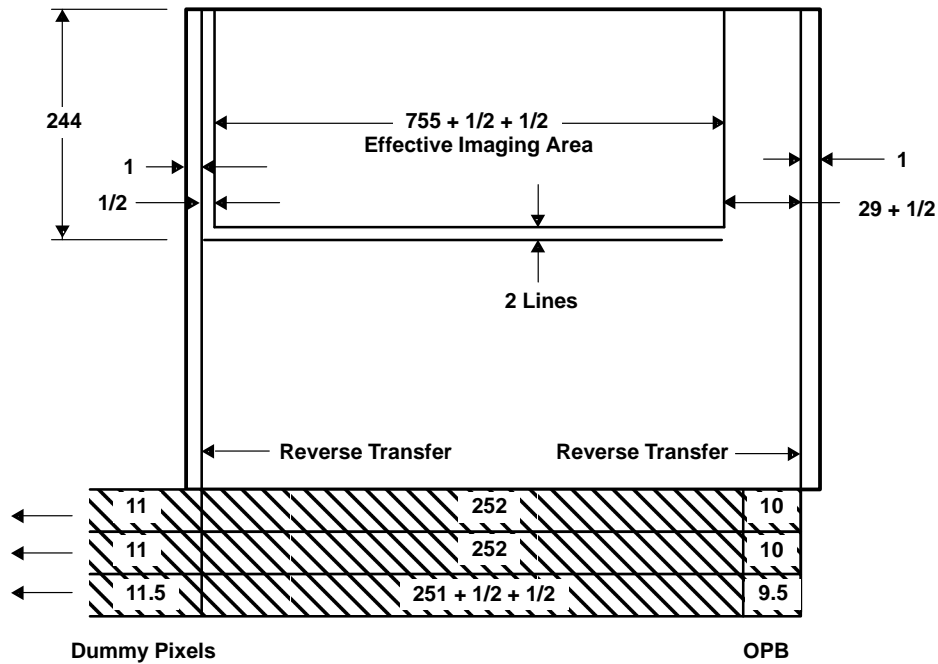

Terminal Functions

NAME	PIN		I/O	DESCRIPTION
	NO.			
ABG†	3		I	Antiblooming gate
ABG†	18		I	Antiblooming gate
ADB	4		I	Supply voltage for amplifier drain bias
AMP GND	8			Amplifier ground
CDB	9		I	Supply voltage for clearing drain bias
IAG†	2		I	Image-area gate
IAG†	19		I	Image-area gate
IDB	11		I	Supply voltage for input diode bias
OUT1	7		O	Output signal 1
OUT2	6		O	Output signal 2
OUT3	5		O	Output signal 3
SAG	17		I	Storage-area gate
SRG1	14		I	Serial-register gate 1
SRG2	15		I	Serial-register gate 2
SRG3	16		I	Serial-register gate 3
SUB†	1			Substrate and clock return
SUB†	10			Substrate and clock return
SUB†	20			Substrate and clock return
TRG	12		I	Transfer gate

† All pins of the same name should be connected together externally.

TC245

786- × 488-PIXEL CCD IMAGE SENSOR

SOCS019A – DECEMBER 1991

image-sensing and storage areas

Figure 1 and Figure 2 show cross sections with potential well diagrams and top views of image-sensing and storage-area elements. As light enters the silicon in the image-sensing area, free electrons are generated and collected in the potential wells of the sensing elements. During this time, blooming protection is activated by applying a burst of pulses to the antiblooming gate inputs every horizontal blanking interval. This prevents blooming caused by the spilling of charge from overexposed elements into neighboring elements. After integration is complete, the signal charge is transferred into the storage area.

There are 29 full columns and one half-column of elements at the right edge of the image-sensing area that are shielded from incident light; these elements provide the dark reference used in subsequent video processing circuits to restore the video black level. There are also one full column and one half-column of light-shielded elements at the left edge of the image-sensing area and two lines of light-shielded elements between the image-sensing and image-storage areas (the latter prevent charge leakage from the image-sensing area into the image-storage area).

multiplexer with transfer gates and serial registers

The multiplexer and transfer gates transfer charge line by line from the storage-area columns into the corresponding serial registers and prepare it for readout. Figure 3 illustrates the layout of the multiplexing gate that vertically separates the pixels for input into the serial registers. Figure 4 shows the layout of the interface region between the serial-register gates and the transfer gates. Multiplexing is activated during the horizontal blanking interval by applying appropriate pulses to the transfer gates and serial registers; the required pulse timing is shown in Figure 5. A drain is also included to provide the capability to clear the image-sensing and storage areas of unwanted charge. Such charge can accumulate in the imager during the start-up of operation or under special circumstances when nonstandard TV operation is desired.

correlated clamp-sample-and-hold amplifier with charge-detection nodes

Figure 6 illustrates the correlated clamp-sample-and-hold amplifier circuit. Charge is converted into a video signal by transferring the charge onto a floating diffusion structure in detection node1 that is connected to the gate of MOS transistor Q1. The proportional charge-induced signal is then processed by the circuit shown in Figure 6. This circuit consists of a low-pass filter formed by Q1 and C2, coupling capacitor C1, dummy detection node 2, which restores the dc bias on the gate of Q3, sampling transistor Q5, holding capacitor C3, and output buffer Q6. Transistors Q2, Q4, and Q7 are current sources for each corresponding stage of the amplifier. The parameters of this high-performance signal-processing amplifier have been optimized to minimize noise and maximize the video signal.

The signal processing begins with a reset of detection node 1 and restoration of the dc bias on the gate of Q3 through the clamping function of dummy detection node 2. After the clamping is completed, the new charge packet is transferred onto detection node 1. The resulting signal is sampled by the sampling transistor Q5 and is stored on the holding capacitor C3. This process is repeated periodically and is correlated to the charge transfer in the registers. The correlation is achieved automatically since the same clock lines used in registers ϕ -S2 and ϕ -S3 for charge transport serve for reset and sample. The multiple use of the clock lines significantly reduces the number of signals required to operate the sensor. The amplifier also contains an internal voltage reference generator that provides the reference bias for the reset and clamp transistors. The detection nodes and the corresponding amplifiers are located some distance away from the edge of the storage area. Therefore, eleven dummy elements are incorporated at the end of each serial register to span the distance. The location of the dummy elements, which are considered to be part of the amplifiers, is shown in the functional block diagram.

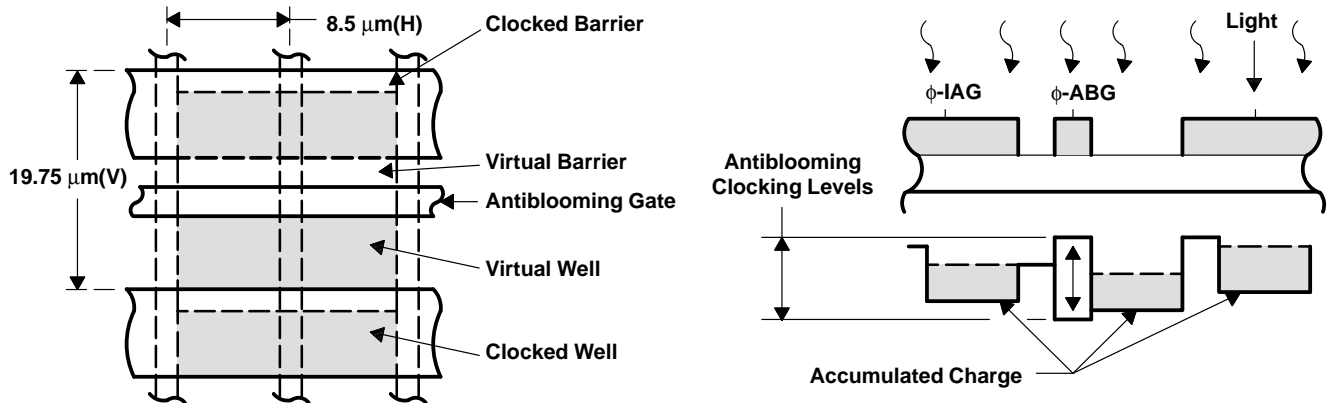

Figure 1. Charge-Accumulation Process

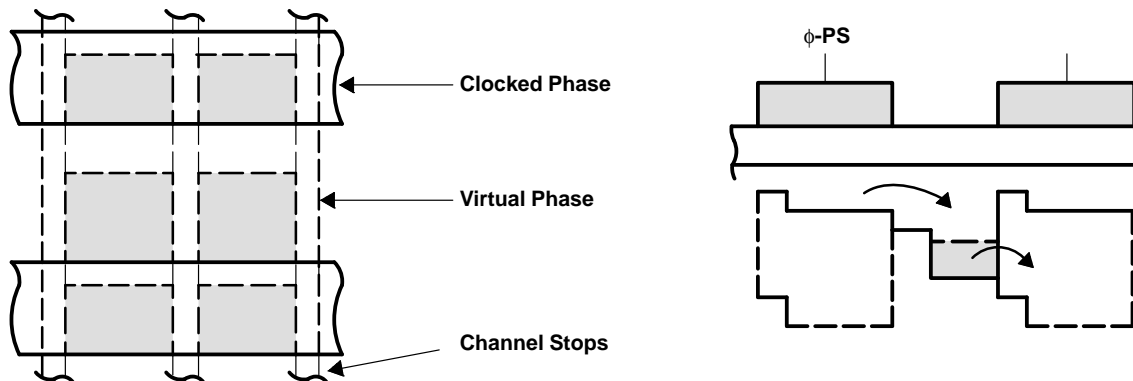

Figure 2. Charge-Transfer Process

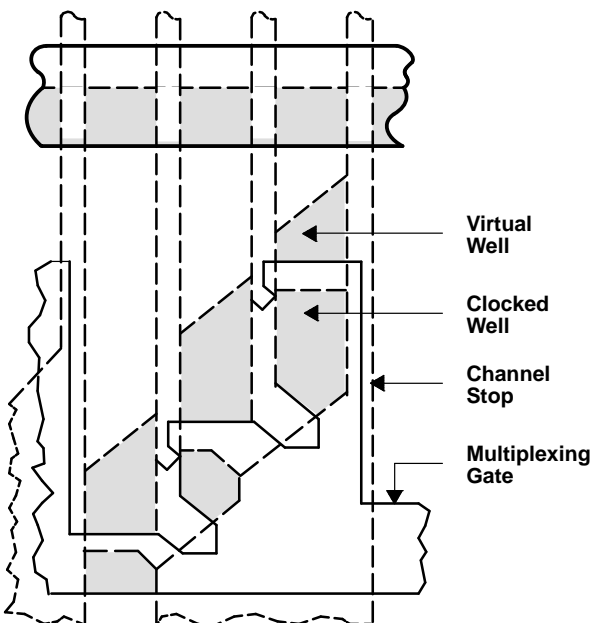

Figure 3. Multiplexing-Gate Layout

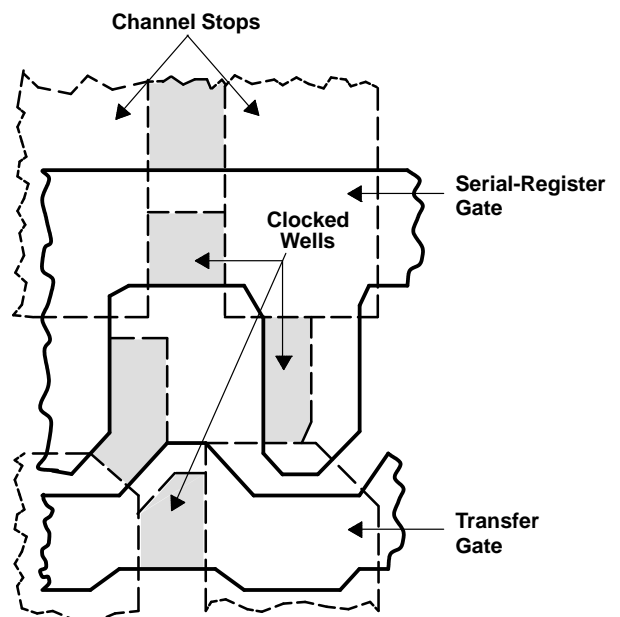

Figure 4. Interface-Region Layout

TC245
786- × 488-PIXEL CCD IMAGE SENSOR

SOCS019A – DECEMBER 1991

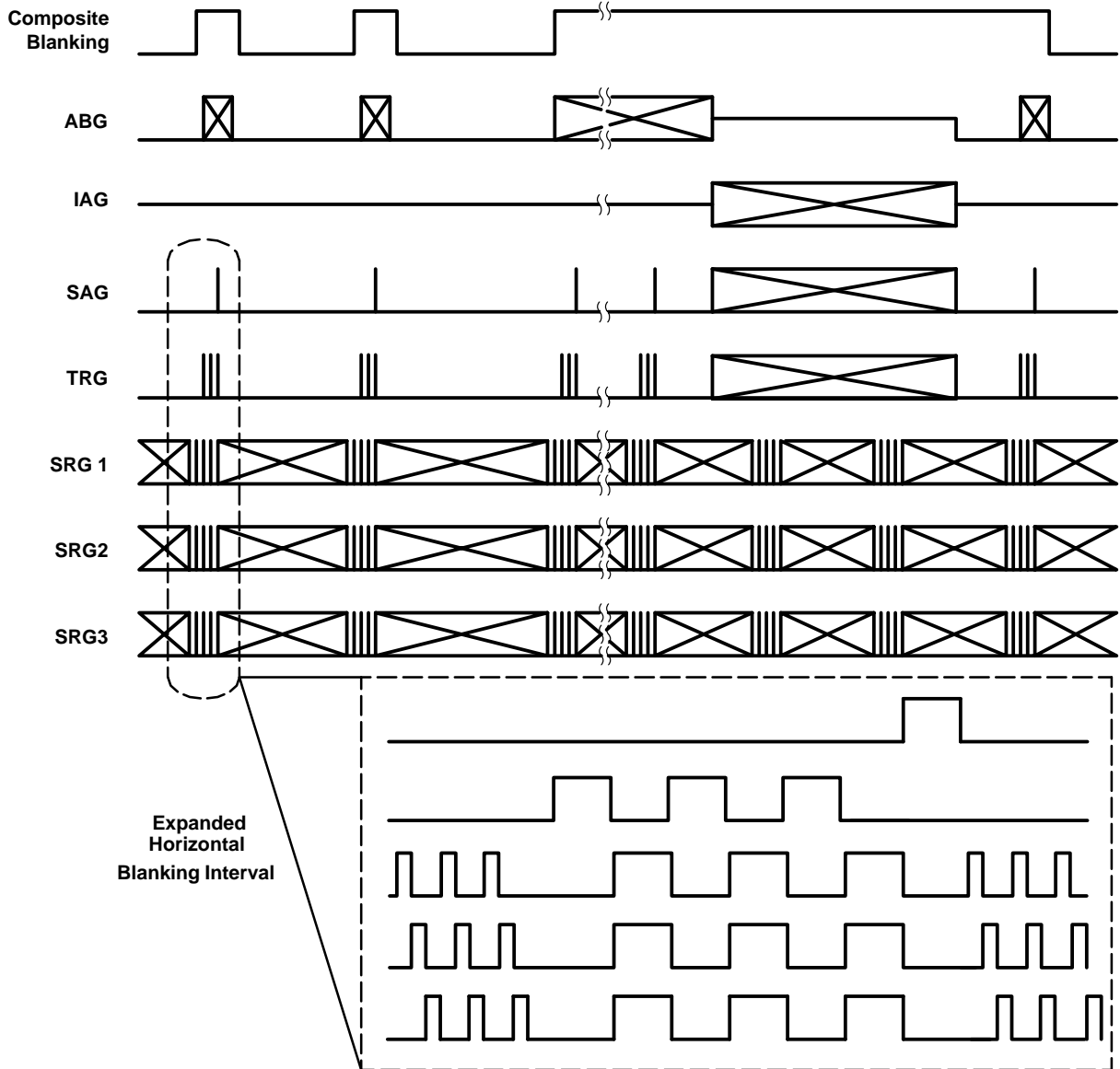

Figure 5. Timing Diagram

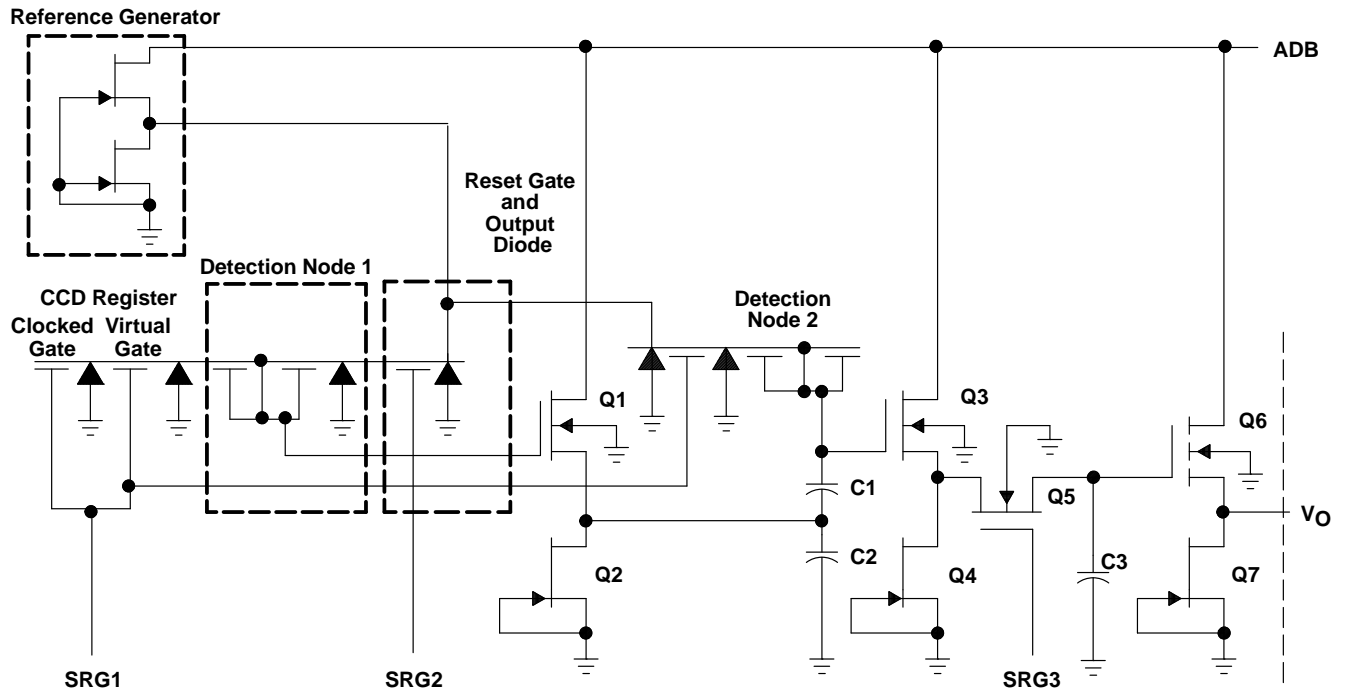

Figure 6. Correlated Clamp-Sample-and-Hold Amplifier Circuit Diagram

TC245 786- × 488-PIXEL CCD IMAGE SENSOR

SOCS019A – DECEMBER 1991

spurious nonuniformity specification

The spurious nonuniformity specification of the TC245 CCD grades –10, –20, –30, and –40 is based on several sensor characteristics:

- Amplitude of the nonuniform pixel
- Polarity of the nonuniform pixel
 - Black
 - White
- Location of the nonuniformity (see Figure 7)
 - Area A
 - Element columns near horizontal center of the area
 - Element rows near vertical center of the area
 - Area B
 - Up to the pixel or line border
 - Up to area A
 - Other
 - Edge of the imager
 - Up to area B
- Nonuniform pixel count
- Distance between nonuniform pixels
- Column amplitude

The CCD sensors are characterized in both an illuminated condition and a dark condition. In the dark condition, the nonuniformity is specified in terms of absolute amplitude as shown in Figure 8. In the illuminated condition, the nonuniformity is specified as a percentage of the total illumination as shown in Figure 9.

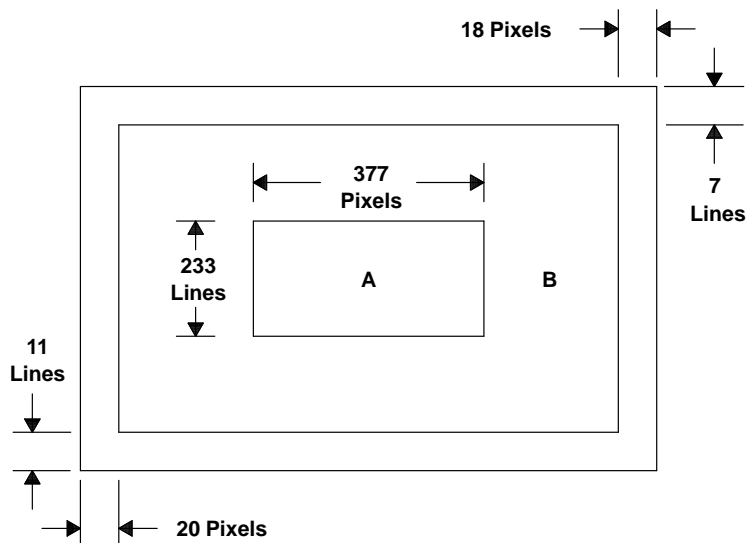

Figure 7. Sensor Area Map

TC245 786- × 488-PIXEL CCD IMAGE SENSOR

SOCS019A – DECEMBER 1991

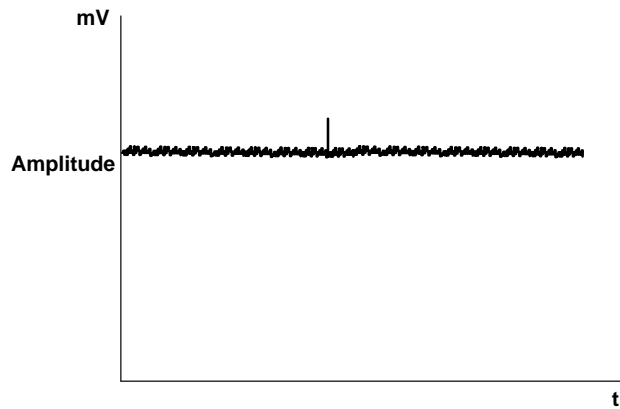

Figure 8. Pixel Nonuniformity, Dark Condition

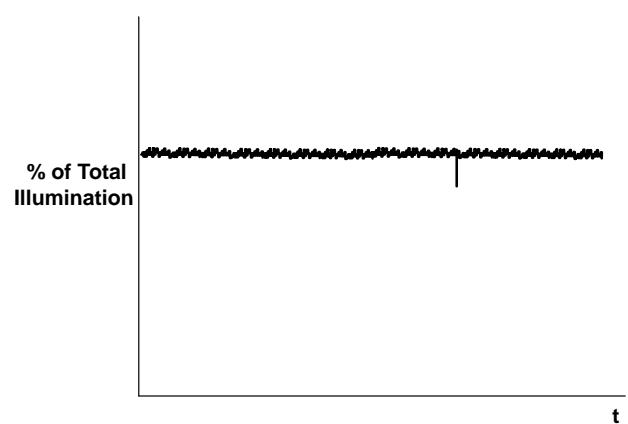

Figure 9. Pixel Nonuniformity, Illuminated Condition

The grade specification for the TC245 is as follows (CCD video-output signal is 50 mV ±10 mV):

Pixel nonuniformity:

PART NUMBER	DARK CONDITION							ILLUMINATED CONDITION			TOTAL COUNT‡	DISTANCE SEPARATION		
	PIXEL AMPLITUDE, x (mV)	NONUNIFORM PIXEL TYPE						% OF TOTAL ILLUMINATION	AREA A	AREA B		X	Y	AREA
		WHITE		BLACK		W/B†								
		AREA		AREA		AREA								
	A	B	A	B	A	B								
TC245-20	$x > 3.5$	0	0	0	0	0	0	$x > 5$	0	0	—	—	—	—
TC245-30	$2.5 < x \leq 3.5$	2	5	2	5	2	5	$5.0 < x \leq 7.5$	2	5	12	100	80	A
	$x > 3.5$	0	0	0	0	0	0	$x > 7.5$	0	0				
TC245-40	$3.5 < x \leq 7$	3	7	3	7	3	7	$7.5 < x \leq 15$	3	7	15	—	—	—
	$x > 7$	0	0	0	0	0	0	$x > 15$	0	0				

† White and black nonuniform pixel pair

‡ The total spot count is the sum of all nonuniform white, black, and white/black pairs in the dark condition added to the number of nonuniform black pixels in the illuminated condition. The sum of all nonuniform combinations will not exceed the total count.

Column nonuniformity:

PART NUMBER	COLUMN AMPLITUDE, x (mV)	WHITE	BLACK
		AREAS A AND B	AREAS A AND B
TC245-20	$x > 0.3$	0	0
TC245-30	$x > 0.5$	0	0
TC245-40	$x > 0.7$	0	0

TC245

786- × 488-PIXEL CCD IMAGE SENSOR

SOCS019A – DECEMBER 1991

absolute maximum ratings over operating free-air temperature range (unless otherwise noted)†

Supply voltage range for ADB, CDB, IDB (see Note 1)	0 V to 15 V
Input voltage range for ABG, IAG, SAG, SRG, TRG	-15 V to 15 V
Operating free-air temperature range, T_A	-30°C to 85°C
Storage temperature range	-30°C to 85°C
Lead temperature 1,6 mm (1/16 inch) from case for 10 seconds	260°C

† Stresses beyond those listed under “absolute maximum ratings” may cause permanent damage to the device. These are stress ratings only, and functional operation of the device at these or any other conditions beyond those indicated under “recommended operating conditions” is not implied. Exposure to absolute-maximum-rated conditions for extended periods may affect device reliability.

NOTE 1: All voltage values are with respect to the substrate terminal.

recommended operating conditions

		MIN	NOM	MAX	UNIT	
Supply voltage, ADB		11	12	13	V	
Substrate bias voltage		0			V	
Input voltage, V_I ‡	IAG	High level	1.5	2	2.5	V
		Intermediate level§	-5.7			
		Low level	-11	-9		
	SRG1, SRG2, SRG3	High level	1.5	2	2.5	
		Low level	-11	-9		
	ABG	High level	2	4	6	
		Intermediate level§	-2.3			
		Low level	-7.5	-7	-6.5	
	SAG	High level	1.5	2	2.5	
		Low level	-11	-9		
	TRG	High level	1.5	2	2.5	
		Low level	-11	-9		
Clock frequency, f_{clock}	IAG, SAG	3.58			MHz	
	SRG1, SRG2, SRG3, TRG	4.77				
	ABG	2				
Capacitive load	OUT1, OUT2, OUT3	6			pF	
Operating free-air temperature, T_A		-10	45		°C	

‡ The algebraic convention, in which the least-positive (most negative) value is designated minimum, is used in this data sheet for clock voltage levels.

§ Adjustment is required for optimal performance.

TC245

786- × 488-PIXEL CCD IMAGE SENSOR

SOCS019A – DECEMBER 1991

electrical characteristics over recommended operating range of supply voltage, $T_A = -10^\circ\text{C}$ to 45°C

PARAMETER		MIN	TYP†	MAX	UNIT
Dynamic range (see Note 2)	Antiblooming disabled (see Note 3)	60	70		dB
Charge conversion factor		3.8	4	4.2	$\mu\text{V}/e$
Charge transfer efficiency (see Note 4)		0.99990	0.99995	1	
Signal response delay time, τ (see Note 5 and Figure 13)		18	20	22	ns
Gamma (see Note 6)		0.97	0.98	0.99	
Output resistance			700	800	Ω
Noise voltage	1/f noise (5 kHz)		0.1		$\mu\text{V}/\sqrt{\text{Hz}}$
	Random noise (f = 100 kHz)		0.08		
Noise equivalent signal			30		electrons
Rejection ratio at 4.77 MHz	ADB (see Note 7)		20		dB
	SRG1, SRG2, SRG3 (see Note 8)		40		
	ABG (see Note 9)		20		
Supply current			5		mA
Input capacitance, C_i	IAG		6500		pF
	SRG1, SRG2, SRG3		68		
	ABG		2400		
	TRG		180		
	SAG		6800		

† All typical values are at $T_A = 25^\circ\text{C}$

- NOTES:
- Dynamic range is -20 times the logarithm of the mean noise signal divided by the saturation output signal.
 - For this test, the antiblooming gate must be biased at the intermediate level.
 - Charge transfer efficiency is one minus the charge loss per transfer in the output register. The test is performed in the dark using an electrical input signal.
 - Signal-response delay time is the time between the falling edge of the SRG clock pulse and the output signal valid state.
 - Gamma (γ) is the value of the exponent in the equation below for two points on the linear portion of the transfer function curve (this value represents points near saturation):

$$\left(\frac{\text{Exposure (2)}}{\text{Exposure (1)}}\right)^\gamma = \left(\frac{\text{Output signal (2)}}{\text{Output signal (1)}}\right)$$

- ADB rejection ratio is -20 times the logarithm of the ac amplitude at the output divided by the ac amplitude at ADB.
- SRGn rejection ratio is -20 times the logarithm of the ac amplitude at the output divided by the ac amplitude at SRGn.
- ABG rejection ratio is -20 times the logarithm of the ac amplitude at the output divided by the ac amplitude at ABG.

TC245

786- × 488-PIXEL CCD IMAGE SENSOR

SOCS019A – DECEMBER 1991

optical characteristics, $T_A = 40^\circ\text{C}$, integration time = 16.67 ms (unless otherwise noted)

PARAMETER			MIN	TYP	MAX	UNIT
Sensitivity	No IR Filter	Measured at V_U (see Notes 10 and 11)	197			mV/lx
	With IR Filter		24			
Saturation signal, V_{sat} (see Note 12)	Antiblooming disabled, interlace off		320			mV
Maximum usable signal, V_{use}	Antiblooming enabled, interlace on		180			mV
Blooming overload ratio (see Note 13)		Interlace on	100			
		Interlace off	200			
Image-area well capacity			80 x 10 ³			electrons
Smear (see Note 14)		See Note 15	0.0004			
Dark current	Interlace off	$T_A = 21^\circ\text{C}$	0.027		nA/cm ²	
Dark signal (see Note 16)	$T_A = 45^\circ\text{C}$	TC245-30	5.5		mV	
		TC245-40	6			
Pixel uniformity	Output signal = 50 mV ±10 mV	TC245-30	3.5		mV	
		TC245-40	5			
Column uniformity	Output signal = 50 mV ±10 mV	TC245-30	0.5		mV	
		TC245-40	0.7			
Shading	Output signal = 100 mV		15%			

NOTES: 10. Sensitivity is measured at an integration time of 16.67 ms with a source temperature of 2856 K. A CM-500 filter is used.

11. V_U is the output voltage that represents the threshold of operation of antiblooming. $V_U \approx 1/2$ saturation signal.

12. Saturation is the condition in which further increase in exposure does not lead to further increase in output signal.

13. Blooming overload ratio is the ratio of blooming exposure to saturation exposure.

14. Smear is a measure of the error induced by transferring charge through an illuminated pixel in shutterless operation. It is equivalent to the ratio of the single-pixel transfer time during a fast dump to the exposure time using an illuminated section that is 1/10 of the image- area vertical height with recommended clock frequencies.

15. Exposure time is 16.67 ms, the fast-dump clocking rate during vertical timing is 3.58 MHz, and the illuminated section is 1/10 of the height of the image section.

16. Dark-signal level is measured from the dummy pixels.

PARAMETER MEASUREMENT INFORMATION

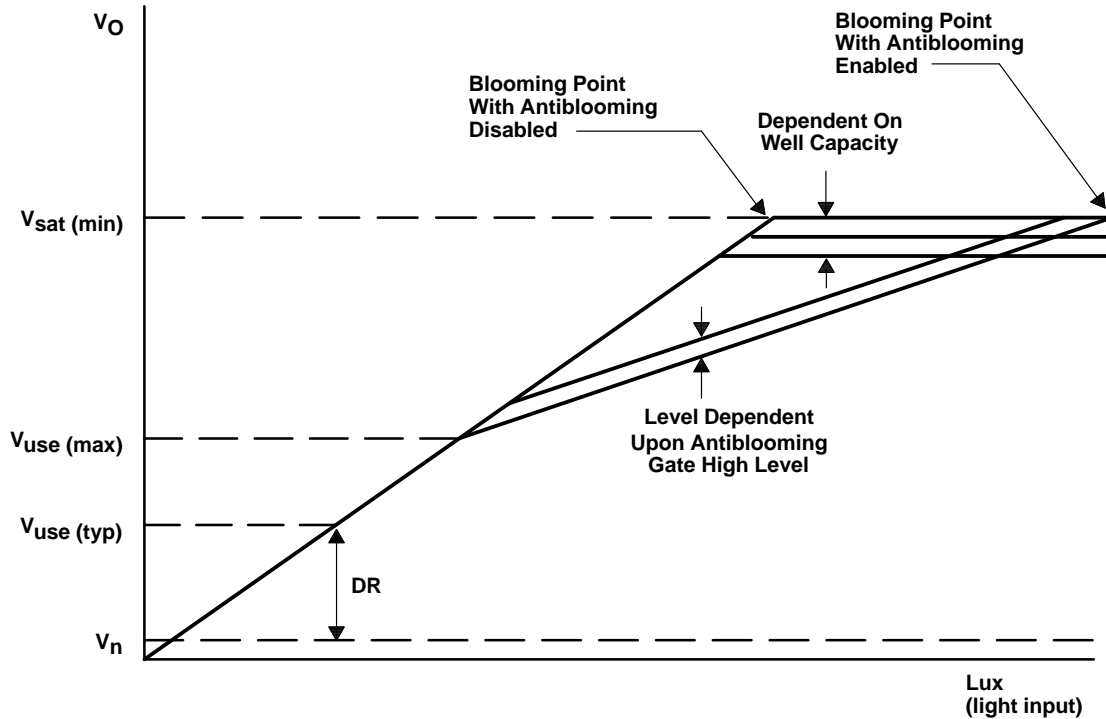

$$DR \text{ (dynamic range)} = \frac{\text{camera white clip voltage}}{V_n}$$

V_n = noise floor voltage

$V_{sat} \text{ (min)}$ = minimum saturation voltage

$V_{use} \text{ (max)}$ = maximum usable voltage

$V_{use} \text{ (typ)}$ = typical user voltage (camera white clip)

- NOTES: A. $V_{use} \text{ (typ)}$ is defined as the voltage determined to equal the camera white clip. This voltage must be less than $V_{use} \text{ (max)}$.
 B. A system trade-off is necessary to determine the system light sensitivity versus the signal/noise ratio. By lowering the $V_{use} \text{ (typ)}$, the light sensitivity of the camera is increased; however, this sacrifices the signal/noise ratio of the camera.

Figure 10. Typical V_{sat} , V_{use} Relationship

TC245 786- × 488-PIXEL CCD IMAGE SENSOR

SOCS019A – DECEMBER 1991

PARAMETER MEASUREMENT INFORMATION

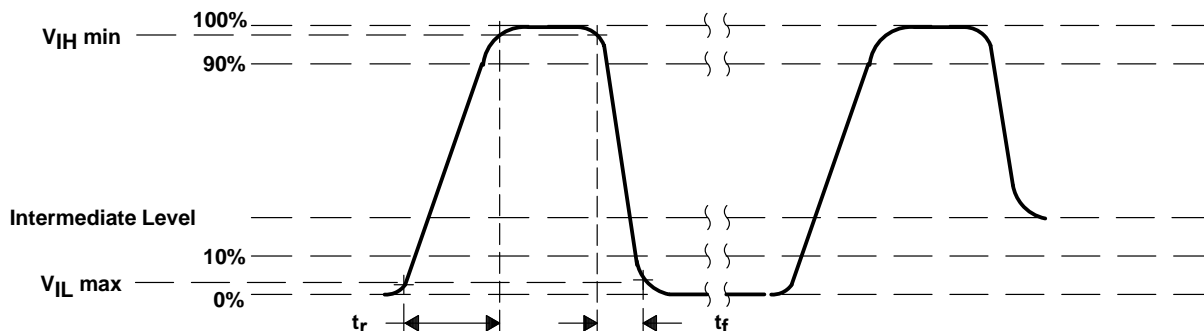

Slew rate between 10% and 90% = 70 to 120 V/ μ s, t_r = 150 ns, t_f = 90 ns.

Figure 11. Typical Clock Waveform for IAG, ABG and SAG

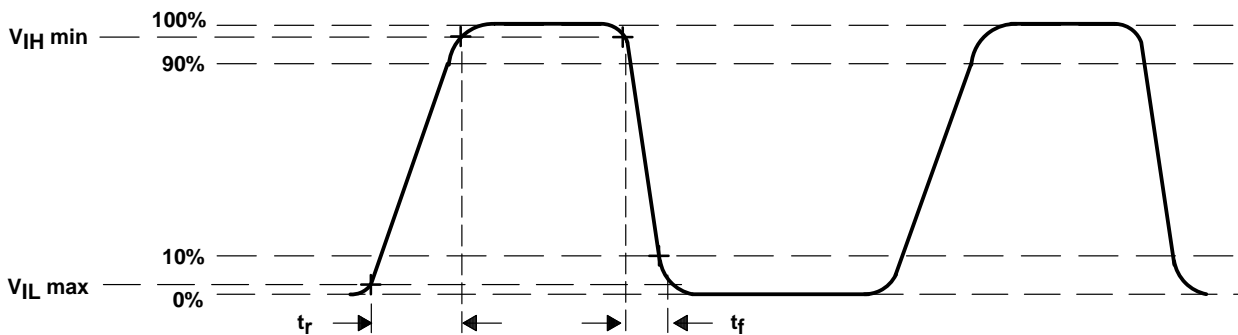

Slew rate between 10% and 90% = 300 V/ μ s, t_r = t_f = 15 ns.

Figure 12. Typical Clock Waveform for SRG and TRG

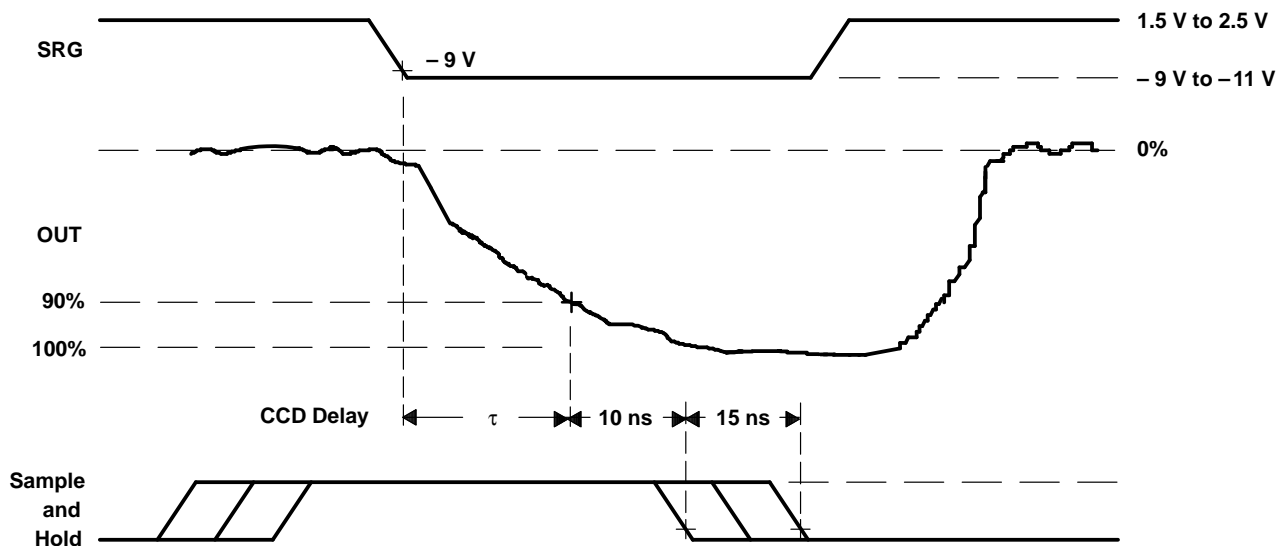

Figure 13. SRG and CCD Output Waveforms

TYPICAL CHARACTERISTICS

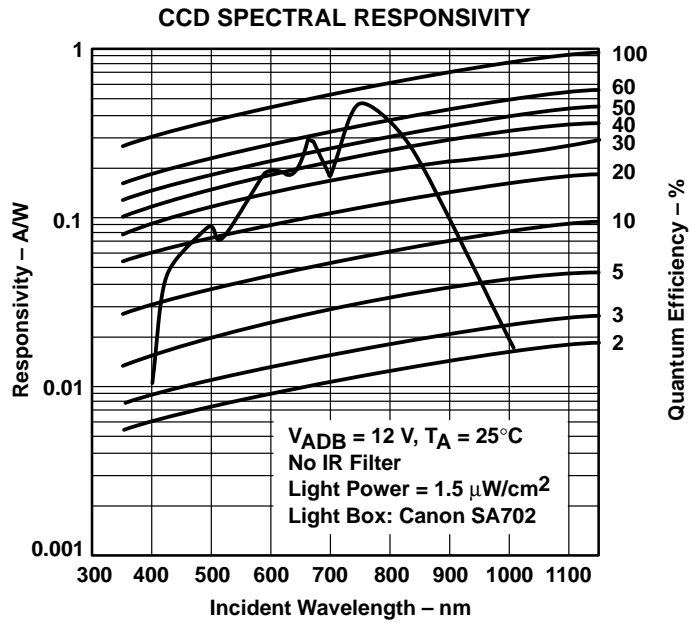

Figure 14

TC245

786- × 488-PIXEL CCD IMAGE SENSOR

SOCS019A – DECEMBER 1991

APPLICATION INFORMATION

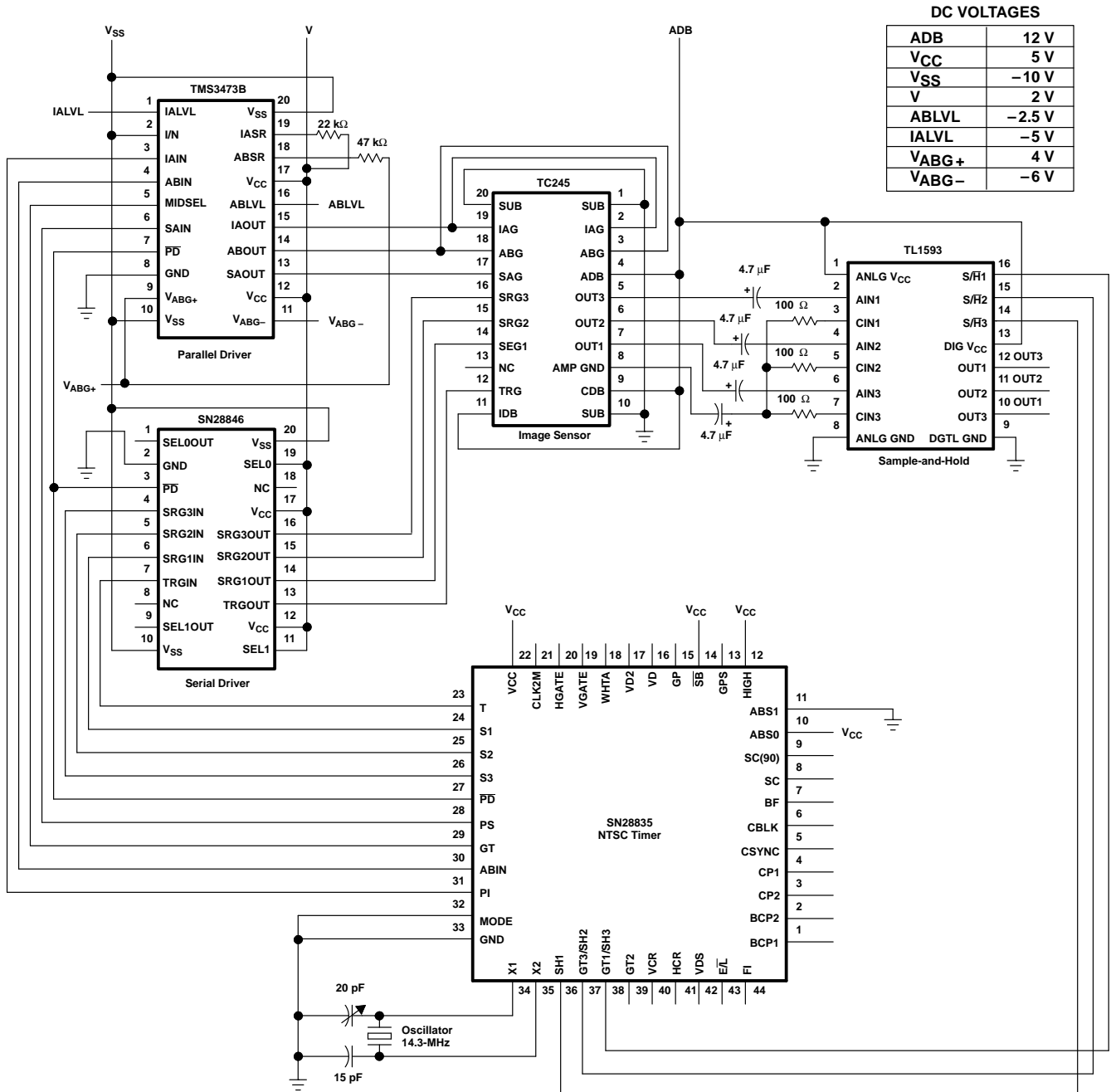

SUPPORT CIRCUITS			
DEVICE	PACKAGE	APPLICATION	FUNCTION
SN28835FS	44 pin flatpack	Timing generator	NTSC timing generator (CCD, S/H, processing)
SN28846DW	20 pin small outline	Serial driver	Driver for TRG, SRG1, SRG2, SRG3
TMS3473BDW	20 pin small outline	Parallel driver	Driver for IAG, SAG, ABG
TL1593CNS	16 pin small outline (EIAJ)	Sample and hold	Three-channel sample-and-hold IC

Figure 15. Typical Application Circuit Diagram

TC245 786- × 488-PIXEL CCD IMAGE SENSOR

SOCS019A – DECEMBER 1991

MECHANICAL DATA

The package for the TC245 consists of a ceramic base, a glass window, and a 20-lead frame. The glass window is sealed to the package by an epoxy adhesive. The package leads are configured in a dual in-line organization and fit into mounting holes with 1,78 mm (0.070 in) center-to-center spacings.

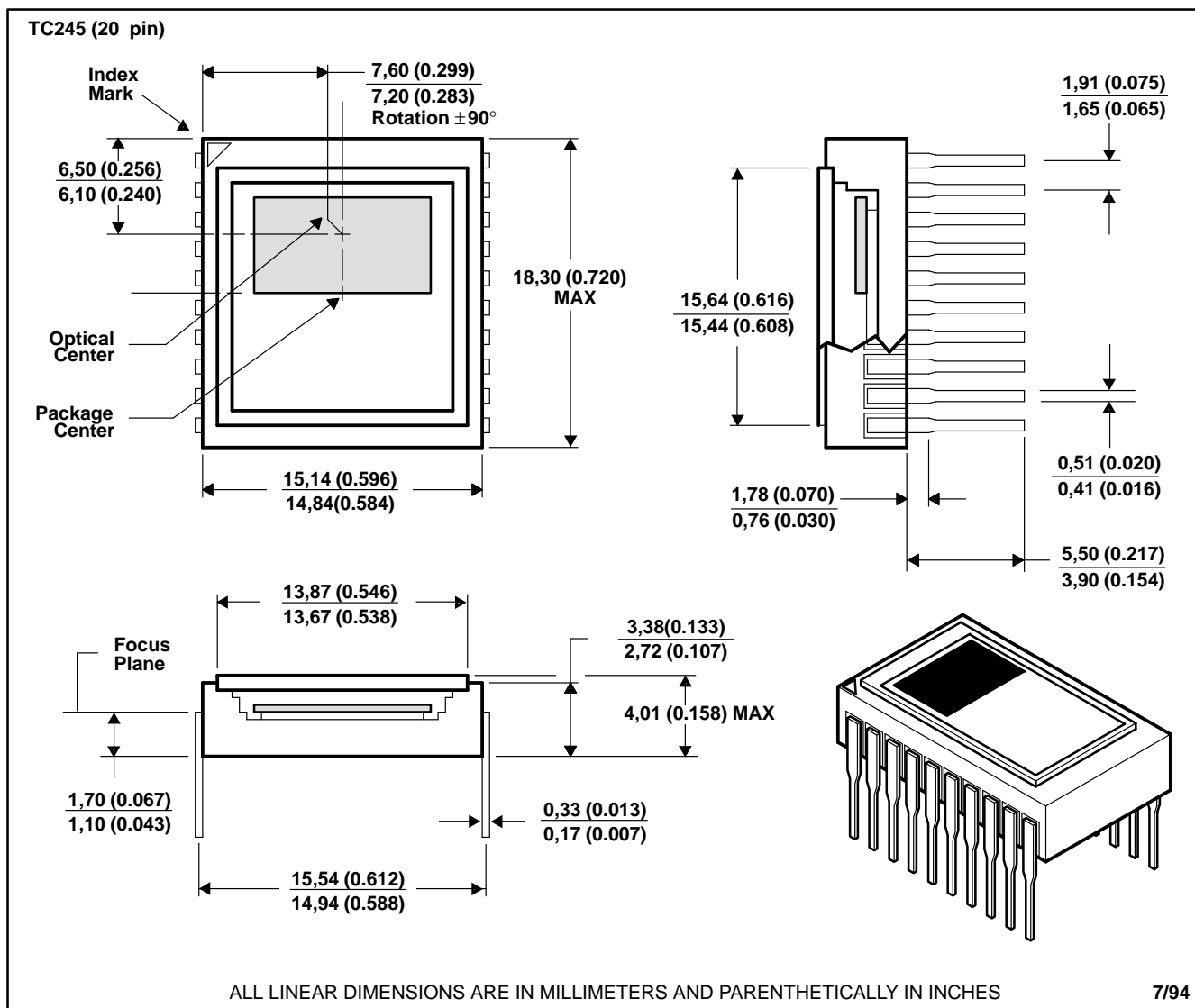

- NOTES: A. The center of the package and the center of image area not coincident.
 B. The distance from the top of the glass to the image sensor surface is typically 1 mm (0.04 inch). The glass is 0.95 ± 0.08 mm thick and has an index of refraction of 1.53.
 C. Each pin centerline is located within 0.18 mm of its true longitudinal position.
 D. Maximum rotation of the sensor within the package is 1.5°.

IMPORTANT NOTICE

Texas Instruments (TI) reserves the right to make changes to its products or to discontinue any semiconductor product or service without notice, and advises its customers to obtain the latest version of relevant information to verify, before placing orders, that the information being relied on is current.

TI warrants performance of its semiconductor products and related software to the specifications applicable at the time of sale in accordance with TI's standard warranty. Testing and other quality control techniques are utilized to the extent TI deems necessary to support this warranty. Specific testing of all parameters of each device is not necessarily performed, except those mandated by government requirements.

Certain applications using semiconductor products may involve potential risks of death, personal injury, or severe property or environmental damage ("Critical Applications").

TI SEMICONDUCTOR PRODUCTS ARE NOT DESIGNED, INTENDED, AUTHORIZED, OR WARRANTED TO BE SUITABLE FOR USE IN LIFE-SUPPORT APPLICATIONS, DEVICES OR SYSTEMS OR OTHER CRITICAL APPLICATIONS.

Inclusion of TI products in such applications is understood to be fully at the risk of the customer. Use of TI products in such applications requires the written approval of an appropriate TI officer. Questions concerning potential risk applications should be directed to TI through a local SC sales office.

In order to minimize risks associated with the customer's applications, adequate design and operating safeguards should be provided by the customer to minimize inherent or procedural hazards.

TI assumes no liability for applications assistance, customer product design, software performance, or infringement of patents or services described herein. Nor does TI warrant or represent that any license, either express or implied, is granted under any patent right, copyright, mask work right, or other intellectual property right of TI covering or relating to any combination, machine, or process in which such semiconductor products or services might be or are used.