



Product Description

Sirenza Microdevices' SNA-486 is a GaAs HBT MMIC Amplifier housed in a low-cost, surface-mountable plastic package. The heterojunction increases breakdown voltage and minimizes leakage current between junctions. Cancellation of emitter junction non-linearities results in higher suppression of intermodulation products.

The use of an external resistor allows for bias flexibility and stability. These unconditionally stable amplifiers are designed for use as general purpose 50 ohm gain blocks.

Also available in chip form (SNA-400), its small size (0.38mm x 0.38mm) and gold metallization make it an ideal choice for use in hybrid circuits.

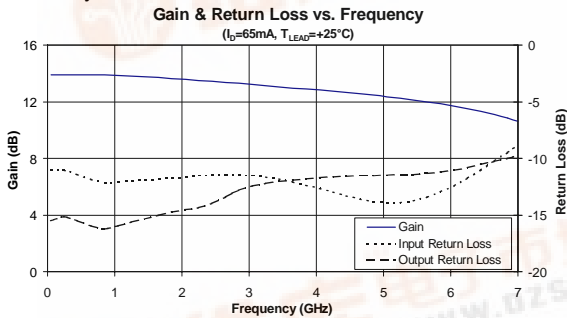

SNA-486

DC-6.5 GHz, Cascadable GaAs MMIC Amplifier

Not Recommended for New Designs
See Application Note AN-017 for Alternates



Product Features

- Patented GaAs HBT Technology
- Cascadable 50 Ohm Gain Block
- +32dBm Output IP3 at 850MHz
- Operates From Single Supply
- Low Cost Surface Mount Plastic Package

Applications

- Cellular, PCS, CDPD, Wireless Data, SONET

Symbol	Parameter	Frequency	Units	Min.	Typ.	Max.
P_{1dB}	Output Power at 1dB Compression	850 MHz	dBm	15.5	17.1	17.5
		1950 MHz	dBm			
		2400 MHz	dBm			
OIP ₃	Output Third Order Intercept Point	850 MHz	dBm	27.9	32.3	30.9
		1950 MHz	dBm			
		2400 MHz	dBm			
S_{21}	Small Signal Gain	850 MHz	dB	12.5	13.9	15.3
		1950 MHz	dB			
		2400 MHz	dB			
Bandwidth	(Determined by S_{11} , S_{22} Values)		MHz		6500	
VSWR _{IN}	Input VSWR	DC-6500 MHz	-		1.7:1	
VSWR _{OUT}	Output VSWR	DC-6500 MHz	-		1.6:1	
S_{12}	Reverse Isolation	850 MHz	dB	18.3	18.2	18.2
		1950 MHz	dB			
		2400 MHz	dB			
NF	Noise Figure	1950 MHz	dB		5.0	6.5
V_D	Device Operating Voltage		V	4.5	5.0	5.5
I_D	Device Operating Current		mA	58	65	72
$R_{\theta JC}$	Thermal Resistance (junction - lead)		$^\circ\text{C/W}$		254	

$V_S = 8\text{V}$

$I_D = 65\text{ mA Typ.}$

OIP₃ Tone Spacing = 1 MHz, Pout per tone = 0 dBm

$R_{BIAS} = 47\text{ Ohms}$

$T_L = 25^\circ\text{C}$

$Z_S = Z_L = 50\text{ Ohms}$

Typical RF Performance at Key Operating Frequencies

Symbol	Parameter	Unit	Frequency (MHz)					
			100	500	850	1950	2400	3500
G	Small Signal Gain	dB	13.9	13.9	13.9	13.6	13.5	13.1
OIP ₃	Output Third Order Intercept Point	dBm		32.0	32.3	30.9	30.6	
P _{1dB}	Output Power at 1dB Compression	dBm		17.0	17.1	17.5	17.5	
IRL	Input Return Loss	dB	11.0	11.6	12.2	11.7	11.5	11.9
ORL	Output Return Loss	dB	15.4	15.6	16.2	14.7	14.1	12.0
S ₁₂	Reverse Isolation	dB	18.3	18.3	18.3	18.2	18.2	18.2
NF	Noise Figure	dB		5.0	5.0	5.0		

Test Conditions: V_G = 8v I_D = 65mA Typ. OIP3 Tone Spacing = 1 MHz, Pout per tone = 0 dBm
R_{BIAS} = 47 Ohms T_L = 25°C Z_S = Z_L = 50 Ohms

Absolute Maximum Ratings

Operation of this device beyond any one of these limits may cause permanent damage. For reliable continuous operation, the device voltage and current must not exceed the maximum operating values specified in the table on page one.

Bias Conditions should also satisfy the following expression:

$$I_D V_D < (T_J - T_L) / R_{TH}, \text{ J}$$

Parameter	Absolute Limit
Max. Device Current (I _D)	110 mA
Max. Device Voltage (V _D)	7 V
Max. RF Input Power	+16 dBm
Max. Junction Temp. (T _J)	+175°C
Operating Temp. Range (T _L)	-40°C to +85°C
Max. Storage Temp.	+150°C

NOTE: While the SNA-486 can be operated at different bias currents, 65 mA is the recommended bias for lower junction temperature and longer life. This reflects typical operating conditions which we have found to be an optimal balance between high IP3 and MTTF. In general, MTTF is improved to more than 100,000 hours when biasing at 65 mA and operating up to 85°C ambient temperature.

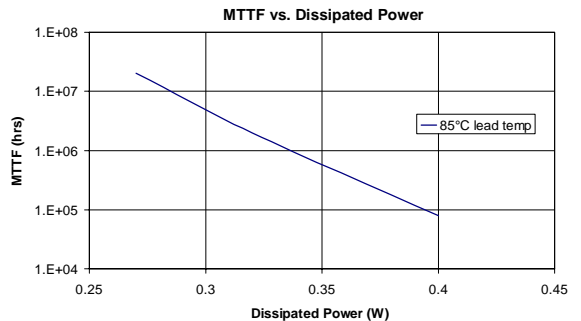
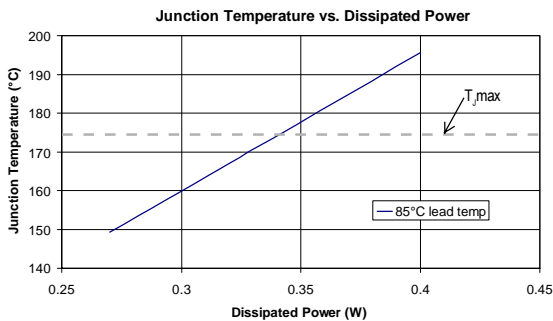

Typical RF Performance ($V_{DS} = 5.0V$, $I_{DS} = 65mA$, $T_{LEAD} = 25^{\circ} C$)

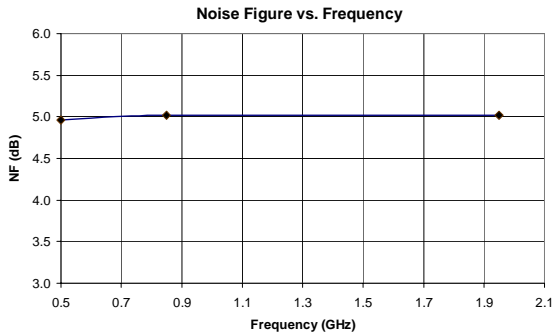
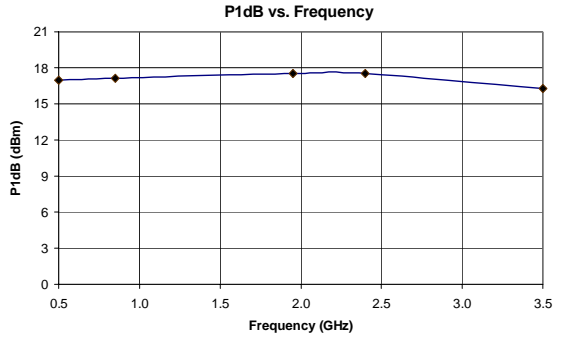
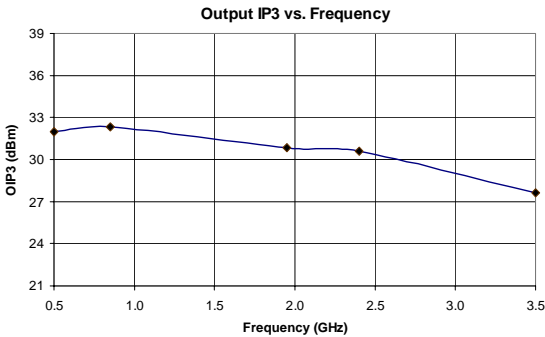
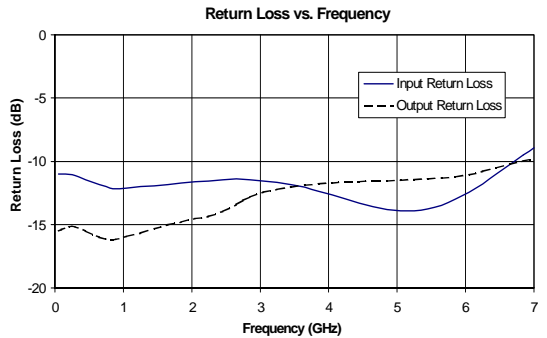
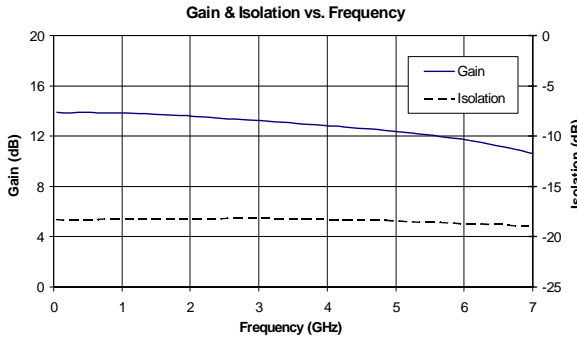

Typical Application Circuit

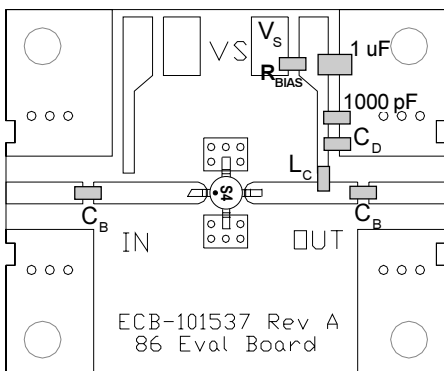
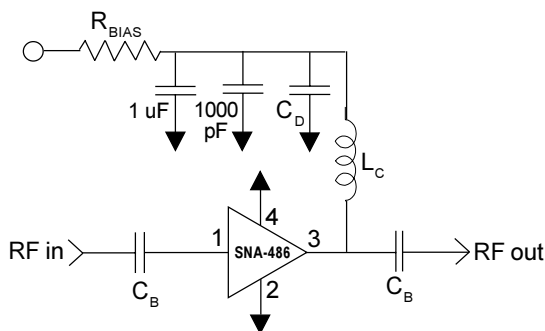

Part Identification Marking

The part will be marked with an "S4" designator on the top surface of the package.

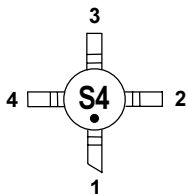

Caution: ESD sensitive

Appropriate precautions in handling, packaging and testing devices must be observed.

Application Circuit Element Values

Reference Designator	Frequency (Mhz)				
	500	850	1950	2400	3500
C _B	220 pF	100 pF	68 pF	56 pF	39 pF
C _D	100 pF	68 pF	22 pF	22 pF	15 pF
L _C	68 nH	33 nH	22 nH	18 nH	15 nH

Recommended Bias Resistor Values for I_D=65mA

$$R_{BIAS} = (V_S - V_D) / I_D$$

Supply Voltage(V _S)	8 V	9 V	12 V	15 V
R _{BIAS}	47 Ω	62 Ω	110 Ω	150 Ω

Note: R_{BIAS} provides DC bias stability over temperature.

Mounting Instructions

1. Use a large ground pad area under device pins 2 and 4 with many plated through-holes as shown.
2. We recommend 1 or 2 ounce copper. Measurements for this data sheet were made on a 31 mil thick FR-4 board with 1 ounce copper on both sides.

Pin #	Function	Description
1	RF IN	RF input pin. This pin requires the use of an external DC blocking capacitor chosen for the frequency of operation.
2, 4	GND	Connection to ground. For optimum RF performance, use via holes as close to ground leads as possible to reduce lead inductance.
3	RF OUT/BIAS	RF output and bias pin. DC voltage is present on this pin, therefore a DC blocking capacitor is necessary for proper operation.

Part Number Ordering Information

Part Number	Reel Size	Devices/Reel
SNA-486-TR1	7"	1000

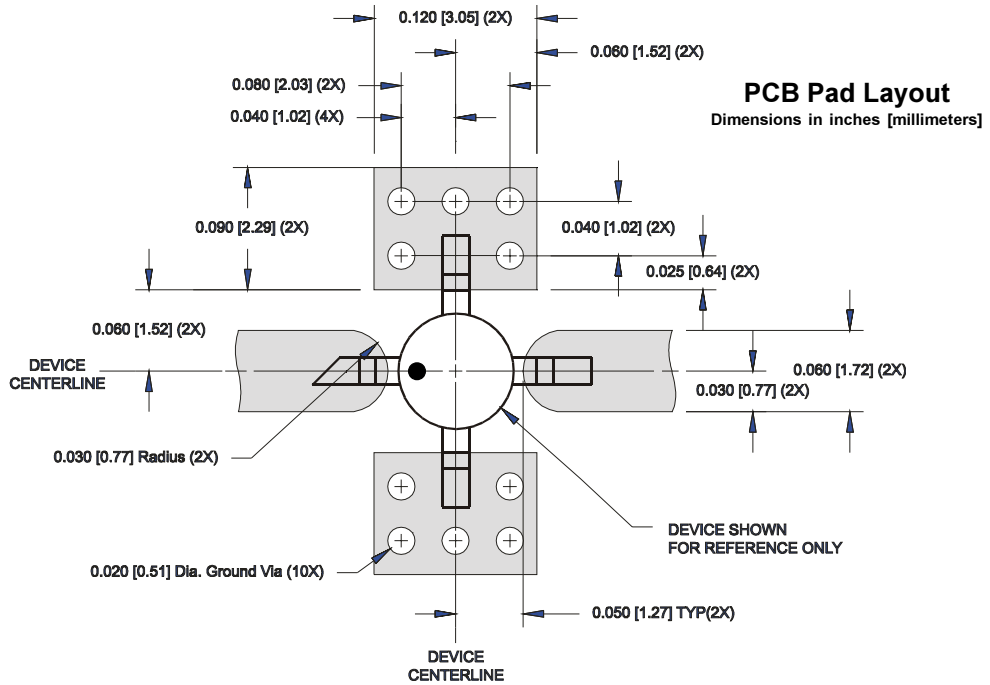

Nominal Package Dimensions

Dimensions in inches [millimeters]

Refer to drawing posted at www.sirenza.com for tolerances.

