

[查询SP2026供应商](#)

[捷多邦, 专业PCB打样工厂, 24小时加急](#)



SP2026

+2.7V to +5.5V USB Power Control Switch

- Compliant to USB Specifications
- +2.7V to +5.5V Input Voltage Range
- Two Independent Power Switches
- Two Error Flag Outputs, Open Drain
- 2.4V Undervoltage Lockout
- 500mA Minimum Continuous Load Current Per Switch
- 1.25A Short Circuit Current Limit
- 140mΩ Maximum On-Resistance
- 100μA On-State Supply Current
- 1μA Shutdown Current
- Output Can Be Forced Higher Than Input (Off-State)
- Thermal Shutdown
- 1ms Soft-Start Power Up
- Active-High Version: SP2026-1
- Active-Low Version: SP2026-2

DESCRIPTION

The SP2026 is a dual +2.7V to +5.5V supervisory power control switch that is current limited to 1.25A and has thermal shutdown to protect itself and the load. A device is disabled in thermal shutdown until the excessive current load is removed, the appropriate enable pins are toggled, or the die temperature cools to 120°C. The undervoltage lockout feature disables the output switches until a valid input voltage, $V_{IN} = 2.4V$, is present. Once a valid input voltage is present and the SP2026 is enabled, a 1ms soft start prevents momentary voltage drops caused by charging a capacitive load. The SP2026 has a low on resistance, 100mΩ, and supplies a 500mA minimum output current per switch. In overcurrent and thermal shutdown, error flags may be asserted for overtemperature.

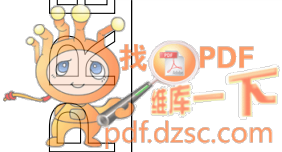
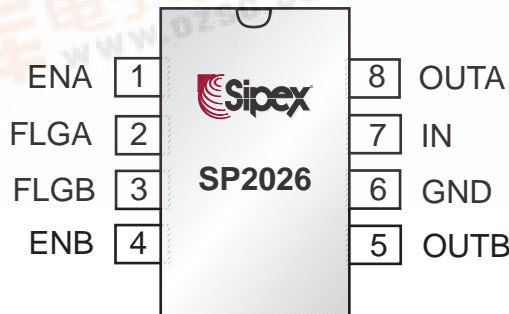

ABSOLUTE MAXIMUM RATINGS

These are stress ratings only and functional operation of the device at these ratings or any other above those indicated in the operation sections of the specifications below is not implied. Exposure to absolute maximum rating conditions for extended periods of time may affect reliability.

Supply Voltage -0.3V, +6.0V
 Operating Temperature -40°C to +85°C
 Storage Temperature -65°C to +150°C

Power Dissipation Per Package
 8-pin NSOIC
 (derate 6.14mW/°C above+70°C) 500mW

8-pin PDIP
 (derate 11.8mW/°C above+70°C). 1000mW
 Fault Flag Voltage +6V
 Fault Flag Current 25mA
 Output Voltage +6V
 Output Current Internally Limited
 Enable Input -0.3V to VIN +3V

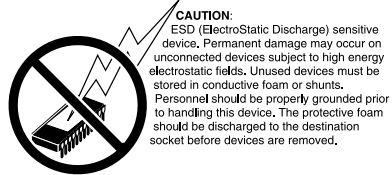

SPECIFICATIONS

Unless otherwise noted, the following specifications apply for $V_{IN} = +5.0V$, $T_A = 25^\circ C$.

PARAMETER	MIN.	TYP.	MAX.	UNITS	CONDITIONS
Operating Voltage Range, V_{IN}	2.7		5.5	V	
Supply Current, I_{IN}		0.75 100	5.0 160	μA μA	enable off, no output load enable on, no output load
Enable Input Threshold Voltage	0.8	1.7 1.45	2.4	V V	low to high transition high to low transition
Enable Input Current	-1.0	0.01	1.0	μA	$V_{EN} = 0V$ to 5.5V
Enable Input Capacitance		1		pF	
Switch Resistance		90 100	140 170	m Ω m Ω	$V_{IN} = 5V$, $I_{OUT} = 500mA$ $V_{IN} = 3.3V$, $I_{OUT} = 500mA$
Output Turn-On Delay		1.3	5.0	ms	$R_L = 10\Omega$ each output, $C_L = 1\mu F$
Output Turn-On Rise Time		1.15	4.9	ms	$R_L = 10\Omega$ each output, $C_L = 1\mu F$
Output Turn-Off Delay		35	100	μs	$R_L = 10\Omega$ each output, $C_L = 1\mu F$
Output Turn-Off Fall Time		32	100	μs	$R_L = 10\Omega$ each output, $C_L = 1\mu F$
Output Leakage Current			10	μA	$V_{EN} \leq 0.8V$
Current Limit Threshold		1.0	1.25	A	ramped load applied to output
Short Circuit Current Limit	0.5	0.9	1.25	A	each output, $V_{OUT} = 0V$
Over-Temperature Shutdown Threshold		140 120 160 150		$^\circ C$ $^\circ C$ $^\circ C$ $^\circ C$	temperature increasing each switch temperature decreasing each switch temperature increasing both switches temperature decreasing both switches
Error Flag Output Resistance		10 15	25 40	Ω Ω	$V_{IN} = 5V, I_L = 10mA$ $V_{IN} = 3.3V, I_L = 10mA$
Error Flag Off Current			10	μA	$V_{FLAG} = 5V$
UVLO Threshold	2.2 2.0	2.4 2.15	2.7 2.3	V V	V_{IN} increasing, T_{MIN} to T_{MAX} V_{IN} decreasing T_{MIN} to T_{MAX}
Enable Input Hysteresis		250		mV	
Off Current in Latched Thermal Shutdown		50			During thermal shutdown state
Short Circuit Response Time		20		μs	$V_{OUT} = 0V$ to $I_{OUT} = 1$ limit
Overcurrent Flag Response Delay	1.5	3.0	7.0	ms	$V_{IN} = 5V$, apply $V_{OUT} = 0V$ until FLG low
		3.0		ms	$V_{IN} = 3.3V$, apply $V_{OUT} = 0V$ until FLG low

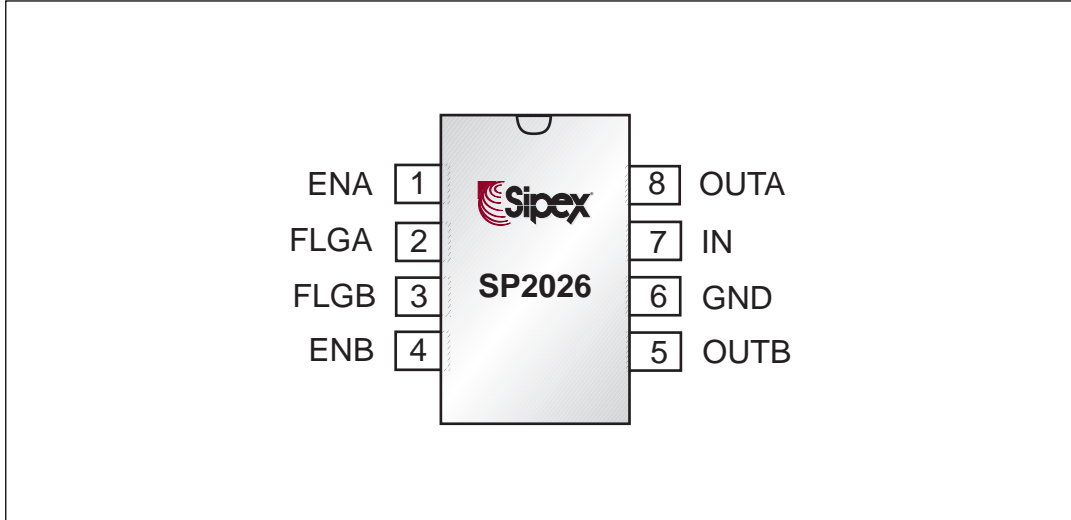

PIN ASSIGNMENTS

PIN NUMBER	PIN SYMBOL	DESCRIPTION
1	ENA	Enable Input for MOSFET Switch A. This input pin is active high for the SP2026-1 and active low for the SP2026-2.
2	FLGA	Fault Flag Output for Switch Channel A. This open drain output pin pulls low to indicate overcurrent and thermal shutdown conditions.
3	FLGB	Fault Flag Output for Switch Channel B. This open drain output pin pulls low to indicate overcurrent and thermal shutdown conditions.
4	ENB	Enable Input for MOSFET Switch B. This input pin is active high for the SP2026-1 and active low for the SP2026-2.
5	OUTA	Output for MOSFET Switch Channel A. This is the output pin of the MOSFET source of channel A, typically connected to the switched side of the load.
6	GND	Ground reference. Supply return.
7	IN	Supply Input. This input pin is connected to the MOSFET drain of both switches. Connect +2.7V to +5.5V to this input pin. The voltage at this input pin also supplies the internal circuitry.
8	OUTB	Output for MOSFET Switch Channel B. This is the output pin of the MOSFET source of channel B, typically connected to the switched side of the load.

FEATURES

Features of the SP2026 device include current limiting, a +2.4V undervoltage lockout, overtemperature shutdown, error flag output, soft start, a switch-on resistance of 100mΩ and a supply current of 100μA. The SP2026-1 device has an active-high enable. The SP2026-2 device has an active-low enable.

THEORY OF OPERATION

The SP2026 is a dual integrated high-side power switch optimized for self-powered and bus-powered Universal Serial Bus (USB) applications. There are operational conditions that will enable or disable one or more of the output MOSFET switches, depending on the type of hazard. Certain conditions will activate the open-drain error flag transistors forcing the flag outputs to ground. The SP2026 provides the following functions:

- 1) Independent Solid State Switches: Independent MOSFET switches connect the IN pin to the OUTA and OUTB pins when enabled by logic signals at the ENA and ENB control pins.
- 2) Fault Flag Conditions: Both the FLGA and FLGB pins are N-channel, open-drain MOSFET outputs capable of sinking a 10mA load to typically 100mV above ground.
- 3) Undervoltage Lockout: The lockout mechanism monitors the input voltage and will enable the MOSFET switches only when the voltage at the V_{IN} pin is greater than +2.4V.
- 4) Current Limiting Threshold: A current limiting threshold prevents damage to the device and external load.
- 5) Thermal Shutdown: The SP2026 has dual sensors to detect overtemperature. If the die temperature reaches 140°C and channel A is in current limit, output switch A is disabled and flag A is asserted. Unless channel B current limits, switch B remains enabled and flag B is not asserted. If the die temperature reaches 140°C and channel B is in current limit, output switch B is disabled and flag B is asserted. Unless channel A current limits, switch A remains enabled and flag A is not asserted. If the die exceeds 160°C, both output switches are disabled and both flags are asserted. A device is

disabled in thermal shutdown until the excessive current load is removed, the appropriate enable pins are toggled, or the temperature cools to 120°C.

Input and Output

The independent solid state MOSFET switches connect the USB +5.0V supply voltage at the IN pin to the OUTA and OUTB pins when enabled by logic signals at ENA and ENB. The IN pin is the power supply connection to the device and the drain of the output MOSFET switches.

Typically, the current will flow through the switches from IN to OUTA and OUTB towards the load. If V_{OUT} is greater than V_{IN} when a switch is enabled, the current will flow from OUTA or OUTB to the IN pin because the MOSFET channels are bidirectional when switched on.

Under normal operating condition, the MOSFET switches will present 100mΩ resistance when closed. The output MOSFETs and driver circuitry are designed to allow the MOSFET source to be externally forced to a higher voltage than the drain when the switch is off.

Fault Flag Conditions

Fault conditions disable one or both MOSFET switches, depending on the type of fault. FLGA and FLGB are N-channel, open-drain MOSFET outputs. The active low fault flag occurs when one of the following conditions exist:

1. Overcurrent
2. Overtemperature

Undervoltage Lockout

This voltage lockout mechanism prevents the MOSFET switches from turning on until V_{IN} is greater than +2.4V.

After the switch turns on, if the voltage at V_{IN} drops below +2.15V, the lockout circuitry shuts off both switches. This detection functions only when at least one MOSFET switch is enabled.

Output Current Limiting

The SP2026 has a preset current-limit threshold. These switch control circuits will implement current limiting which prevents damage to the SP2026 and the external load while allowing a minimum current of 0.5A to be delivered to the load.

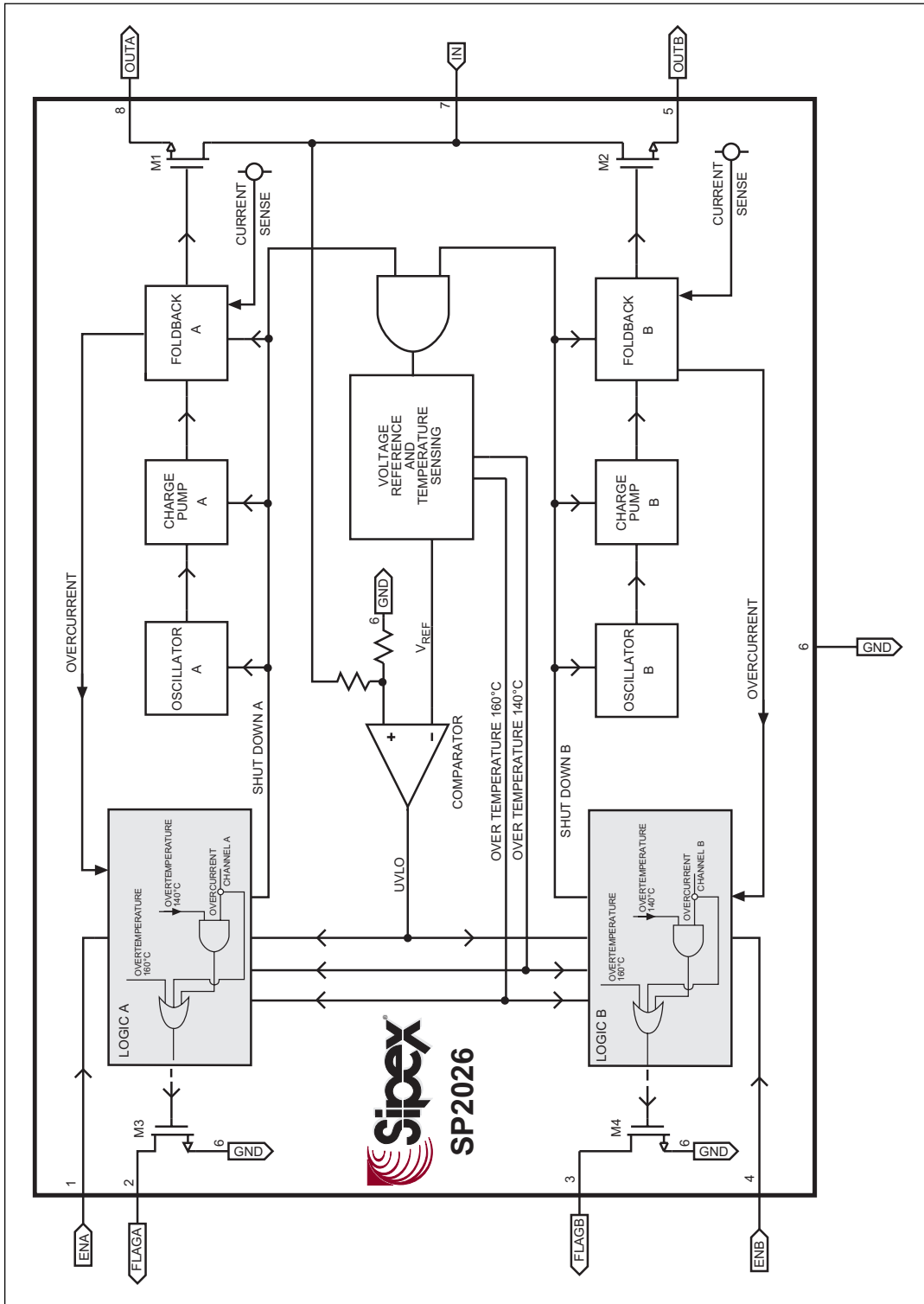

Figure 1. Internal Block Diagram for the SP2026

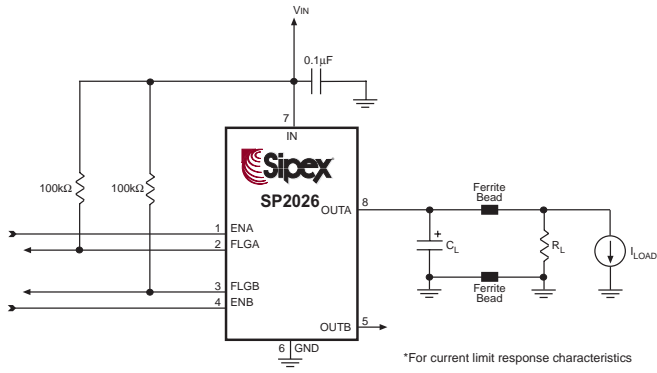

Figure 2. Test Circuit for the SP2026

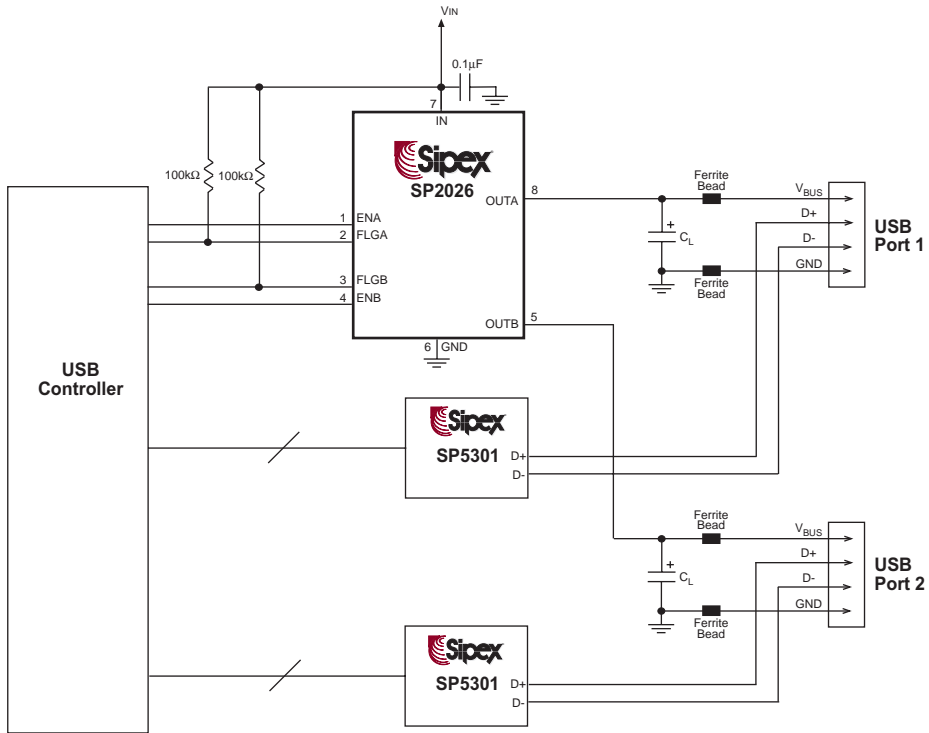

Figure 3. Typical Application Circuit for the SP2026

The SP2026 MOSFET switches will exhibit very low resistance (100m Ω) or voltage drop until the current limit is reached. The fold back current is the current that is delivered into a short circuit at the output.

If the SP2026 MOSFET switch is enabled into a heavy load or short-circuit, the switch will immediately go into a constant-current mode, reducing the output voltage. The respective fault flag will pull low until the condition is removed.

When a heavy load is connected to the SP2026 switch output, a large transient current may flow until the current limiting circuitry responds.

The SP2026 will provide a low resistance switch (100m Ω) between the input and output pins. This low resistance will be maintained with increasing current until the 1.25A limit is reached. If load current exceeds this limit, the switches will increase their resistance. The foldback current (500mA minimum) is reached when there is a short applied to either output. The 100m Ω switch resistance is guaranteed for all load currents, increasing or decreasing, that are below 500mA.

Thermal Shutdown

Under nominal load conditions, the switch resistances are very low and internal power dissipation is low. Under short circuit conditions, current is limited and internal power dissipation is higher but not extreme. Under intermediate load conditions, both the voltage across the switch and the current through the switch are at intermediate values and internal power dissipation is highest. In this last condition, the die temperature will reach the thermal limit and the switches in both channels will be shut off. As the die subsequently cools, the switch will turn on again. If the load is not removed, the device will thermal cycle in this manner to protect itself from damage.

The SP2026 has dual sensors to detect overtemperature. If the die temperature reaches 140°C and channel A is in current limit, output switch A is disabled and flag A is asserted. Unless channel B current limits, switch B remains enabled and flag B is not asserted. If the die temperature reaches 140°C and channel B is in current limit, output switch B is disabled and flag B is asserted. Unless channel A current limits, switch A remains enabled and flag A is not asserted. If the die exceeds 160°C, both

output switches are disabled and both flags are asserted. A device is disabled in thermal shutdown until the excessive current load is removed, the appropriate enable pins are toggled, or the temperature cools to 120°C.

The delay between a current limit fault and thermal shutdown will vary with ambient temperature, board layout, and load impedance, but is typically several hundred milliseconds. A designer can command a USB controller to recognize the fault and disable the appropriate channel within this time.

TYPICAL APPLICATIONS

Bypass Capacitors

A 0.1 μ F to 1.0 μ F bypass capacitor from the IN pin to the GND pin is recommended to control power supply transients. Refer to *Figure 4*. Without a bypass capacitor, an output short may cause sufficient ringing and damage the device. Without a bypass capacitor, excessive supply lead inductance is also a concern.

Input or output transients must not exceed the absolute maximum supply voltage of $V_{IN(MAX)} = +6.0V$ even for a short duration to avoid risk of damage to the device.

Soft Start Condition

The soft start feature of the SP2026 is implemented by holding the output turn-on rise time to 1ms. When off, the device has high impedance MOSFET channels that slowly become low impedance as the device powers on. This prevents an inrush current from causing voltage drops that result from charging a capacitive load and can pull the USB voltage bus below specified levels. This satisfies the USB voltage droop requirements for bus-powered applications. Refer to the circuit in *Figure 6*.

The SP2026 can provide inrush current limiting for applications with large load capacitances where $C_{BULK} > 10\mu F$. Refer to the circuit in *Figure 7* for a configuration that will meet USB transient regulation specifications with large load capacitances.

Enable Input

The ENA and ENB control pins must be driven to a logic high or logic low for a clearly defined signal input. Floating these control lines may cause unpredictable operation.

USB Compliance

The SP2026 is ideal for self-powered and bus-powered Universal Serial Bus (USB) applications. A USB port provides a +5.0V bus and ground return line in addition to a twisted pair for data.

The SP2026 will comply with the following USB requirements:

- 1) The fault current is well below the UL 25VA safety requirements;
- 2) The Flag Outputs are available to indicate fault conditions to USB controllers;
- 3) The MOSFET switches' low on-resistance meets USB voltage drop requirements;
- 4) Each MOSFET switch channel can supply 500mA as required by USB downstream devices;
- 5) Soft start eliminates any momentary voltage drops on the upstream port that may occur when the switches are enabled in bus-powered applications.

Refer to *Table 1* for a USB compliance summary of the SP2026. Additional features include the following:

- 6) An Undervoltage Lockout ensures that the device remains off unless there is a valid input supply voltage present;
- 7) +2.7V and +5.0V logic compatible enable inputs;
- 8) Thermal Shutdown prevents the possibility of catastrophic switch failure from high-current loads;
- 8) The device is available in both active-high and active-low versions.

Refer to *Figures 7 to 14* for typical performance characteristics of the SP2026.

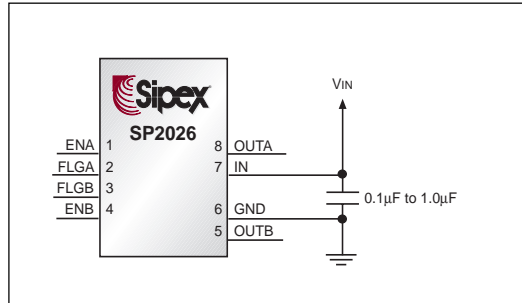

Figure 4. Bypass Capacitor at the Supply Pins

USB REQUIREMENT	SP2026 COMPLIANT FEATURE
Inrush current limiting required	Soft start turns on in 1ms
Suspend State of <500µA Required	Suspend Current of 1µA maximum
Bus powered hubs must have 350mV drop from cable plug to port	Switch on resistance of 140mΩ maximum (translates to 70mV at 500mA)
Voltage supplied to host or hub port is +4.75V to +5.25V	Operating range of +2.7V to +5.5V
A device that draws bus power must have a stable supply within 100ms of VBUS reaching +4.4V	Turns on in 1ms
Over-current reporting capability required	Open drain fault flags

Table 1. USB Protocol Compliance of the SP2026 device

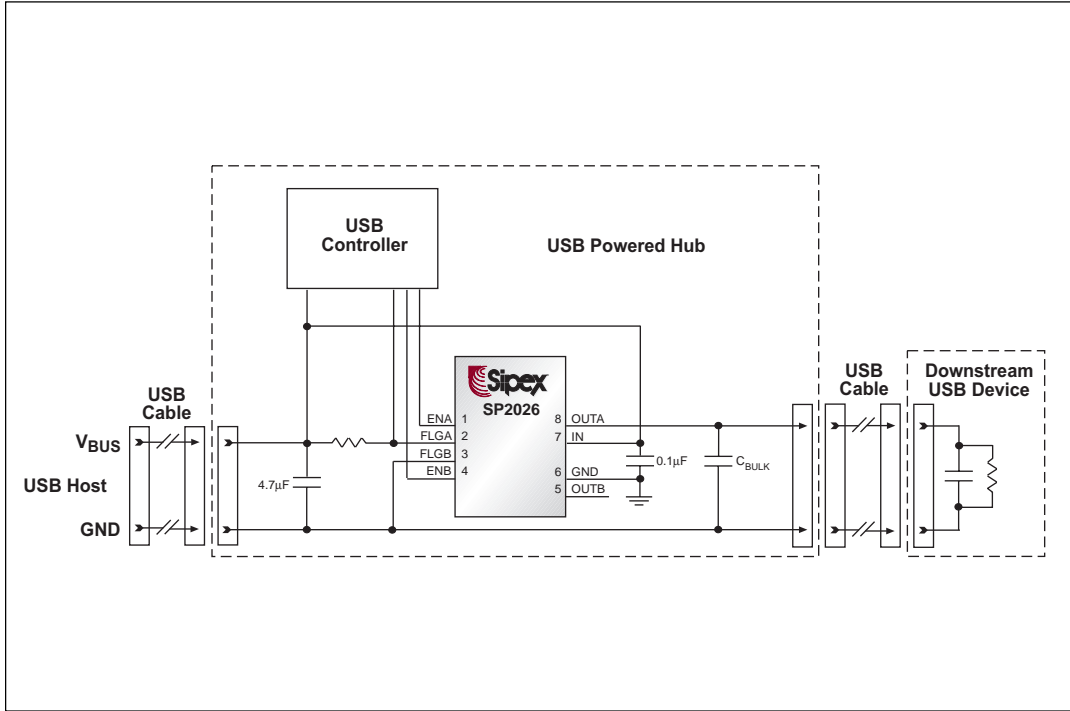

Figure 5. Soft Start Circuit Configuration for a Single Channel USB-powered Application with the SP2026

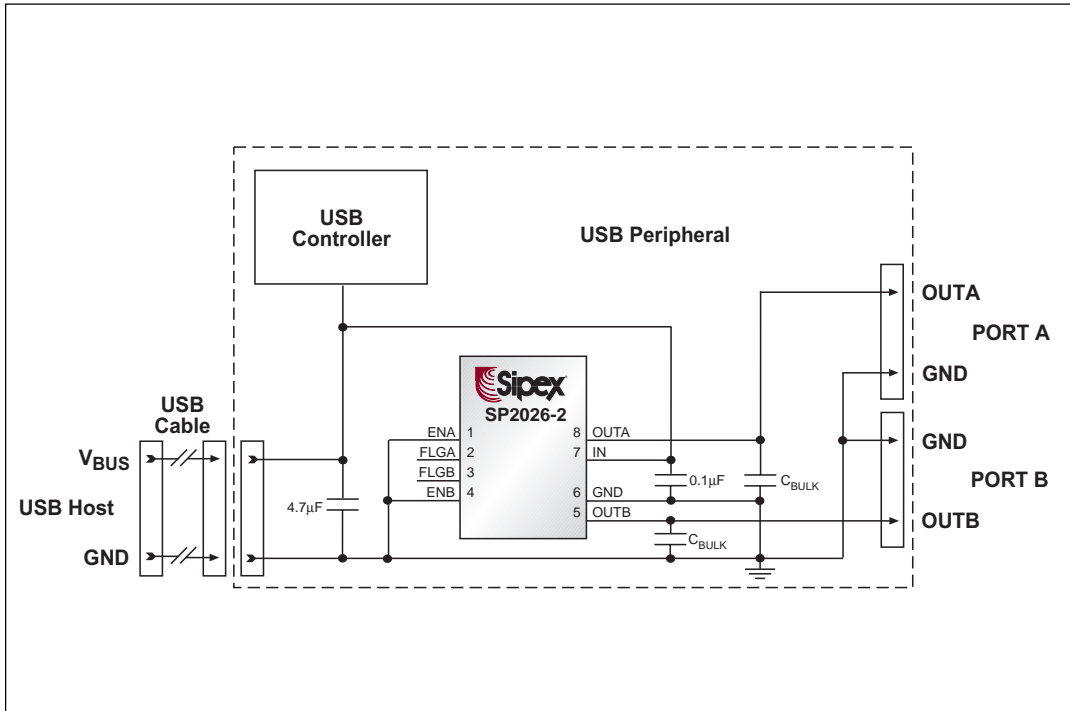

Figure 6. Soft Start Circuit Configuration for SP2026 Applications with Large Load Capacitances

PERFORMANCE CHARACTERISTICS

$V_{IN} = +5.0V$, single MOSFET switch section, and $T_{AMB} = +25^{\circ}C$ unless otherwise noted.

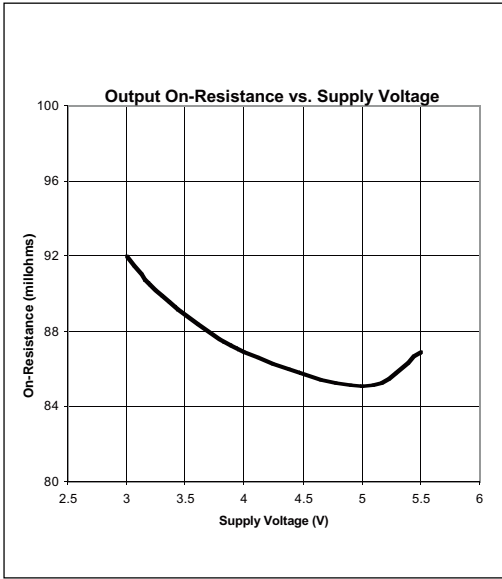

Figure 7. Output On-Resistance vs. Supply Voltage

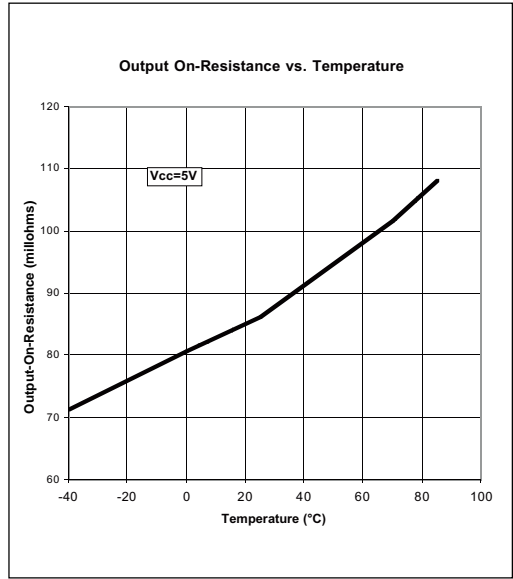

Figure 8. Output On-Resistance vs. Temperature

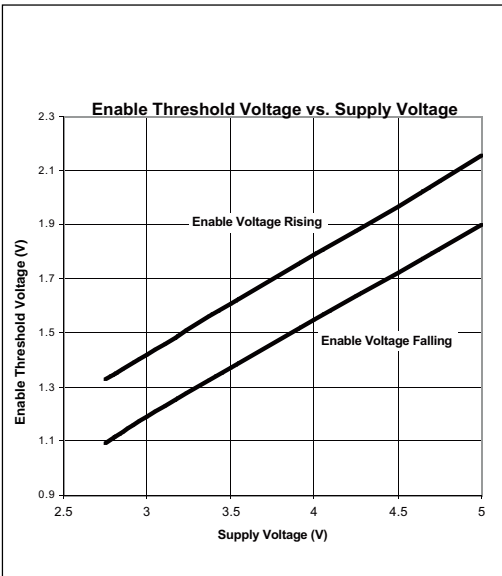

Figure 9. Control Threshold vs. Supply Voltage

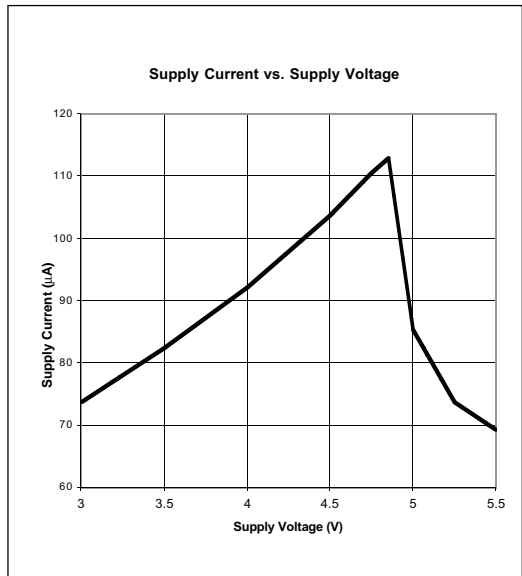

Figure 10. On-state Supply Current vs. Supply Voltage

PERFORMANCE CHARACTERISTICS (continued)

$V_{IN} = +5.0V$, single MOSFET switch section, and $T_{AMB} = +25^{\circ}C$ unless otherwise noted.

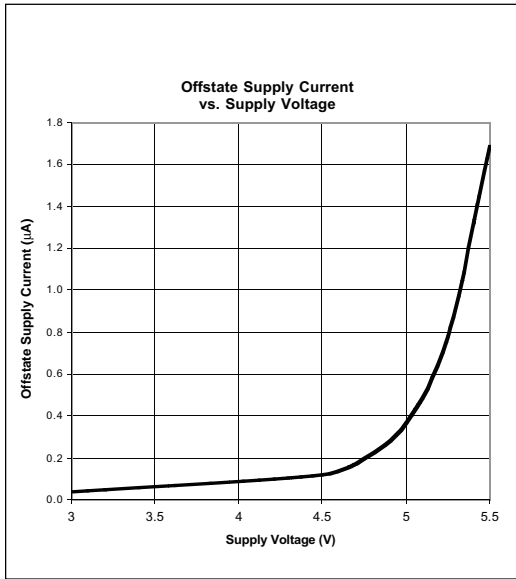

Figure 11. Off-state Supply Current vs. Supply Voltage

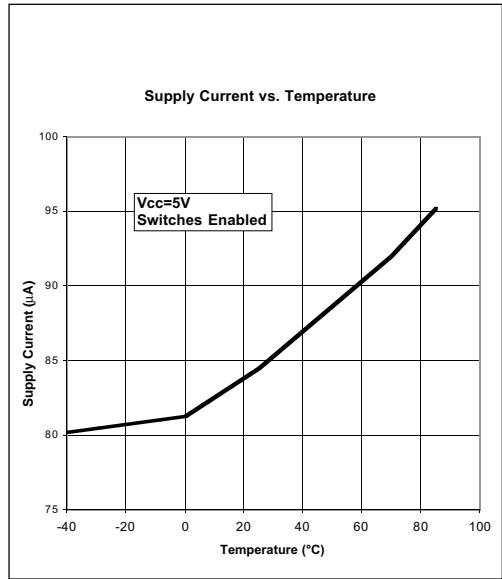

Figure 12. On-state Supply Current vs. Temperature

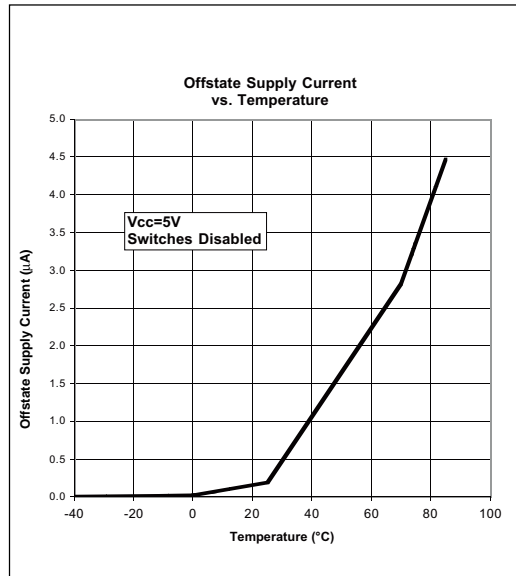

Figure 13. Off-state Supply Current vs. Temperature

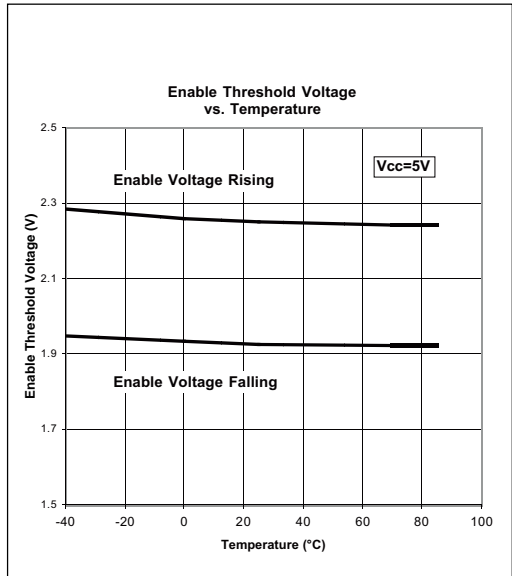
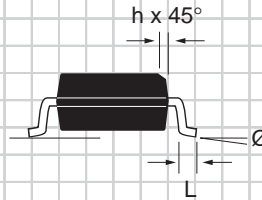
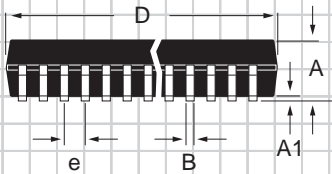
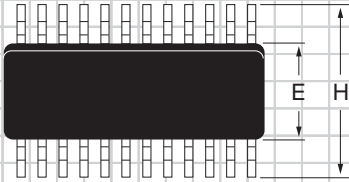

Figure 14. Control Threshold vs. Temperature

**PACKAGE: PLASTIC
SMALL OUTLINE (SOIC)
(NARROW)**



DIMENSIONS (Inches) Minimum/Maximum (mm)	8-PIN	14-PIN	16-PIN
A	0.053/0.069 (1.346/1.748)	0.053/0.069 (1.346/1.748)	0.053/0.069 (1.346/1.748)
A1	0.004/0.010 (0.102/0.249)	0.004/0.010 (0.102/0.249)	0.004/0.010 (0.102/0.249)
B	0.014/0.019 (0.35/0.49)	0.013/0.020 (0.330/0.508)	0.013/0.020 (0.330/0.508)
D	0.189/0.197 (4.80/5.00)	0.337/0.344 (8.552/8.748)	0.386/0.394 (9.802/10.000)
E	0.150/0.157 (3.802/3.988)	0.150/0.157 (3.802/3.988)	0.150/0.157 (3.802/3.988)
e	0.050 BSC (1.270 BSC)	0.050 BSC (1.270 BSC)	0.050 BSC (1.270 BSC)
H	0.228/0.244 (5.801/6.198)	0.228/0.244 (5.801/6.198)	0.228/0.244 (5.801/6.198)
h	0.010/0.020 (0.254/0.498)	0.010/0.020 (0.254/0.498)	0.010/0.020 (0.254/0.498)
L	0.016/0.050 (0.406/1.270)	0.016/0.050 (0.406/1.270)	0.016/0.050 (0.406/1.270)
Ø	0°/8° (0°/8°)	0°/8° (0°/8°)	0°/8° (0°/8°)

PRELIMINARY INFORMATION

ORDERING INFORMATION

Model	Temperature Range	Package Types
SP2026-1EN	-40°C to +85°C	8-pin NSOIC
SP2026-1EN/TR	-40°C to +85°C	(Tape & Reel) 8-pin NSOIC
SP2026-2EN	-40°C to +85°C	8-pin NSOIC
SP2026-2EN/TR	-40°C to +85°C	(Tape & Reel) 8-pin NSOIC



SIGNAL PROCESSING EXCELLENCE

Sipex Corporation

Headquarters and Sales Office

22 Linnell Circle
Billerica, MA 01821
TEL: (978) 667-8700
FAX: (978) 670-9001
e-mail: sales@sipex.com

Sales Office

233 South Hillview Drive
Milpitas, CA 95035
TEL: (408) 934-7500
FAX: (408) 935-7600

Sipex Corporation reserves the right to make changes to any products described herein. Sipex does not assume any liability arising out of the application or use of any product or circuit described herein; neither does it convey any license under its patent rights nor the rights of others.