

FAIRCHILD
SEMICONDUCTOR®

SPT9713

12-BIT, 100 MWPS TTL D/A CONVERTER

TECHNICAL DATA

FEBRUARY 15, 2001

FEATURES

- 12-Bit, 100 MWPS digital-to-analog converter
- TTL compatibility
- Low power: 640 mW
- 1/2 LSB DNL
- 40 MHz multiplying bandwidth
- Industrial temperature range
- Superior performance over AD9713
 - Improved settling time of 13 ns
 - Improved glitch energy 15 pV-s
 - Master-slave latches

APPLICATIONS

- Fast frequency hopping spread spectrum radios
- Direct sequence spread spectrum radios
- Microwave and satellite modems
- Test & measurement instrumentation

GENERAL DESCRIPTION

The SPT9713 is a 12-bit, 100 MWPS digital-to-analog converter designed for direct digital synthesis, high resolution imaging, and arbitrary waveform generation applications.

This device is pin-for-pin compatible with the AD9713 with significantly improved performance. The only difference between the SPT9713 and the AD9713 is that the Latch Enable (LE, pin 26) for the SPT9713 is rising-edge triggered

(see figure 1), whereas the Latch Enable (LE, pin 26) for the AD9713 functions in the transparent mode.

The SPT9713 is a TTL-compatible device. It features a fast settling time of 13 ns and low glitch impulse energy of 15 pV-s, which results in excellent spurious-free dynamic range characteristics.

The SPT9713 is available in a 28-lead PLCC package in the industrial temperature range (-40 to +85 °C).

BLOCK DIAGRAM

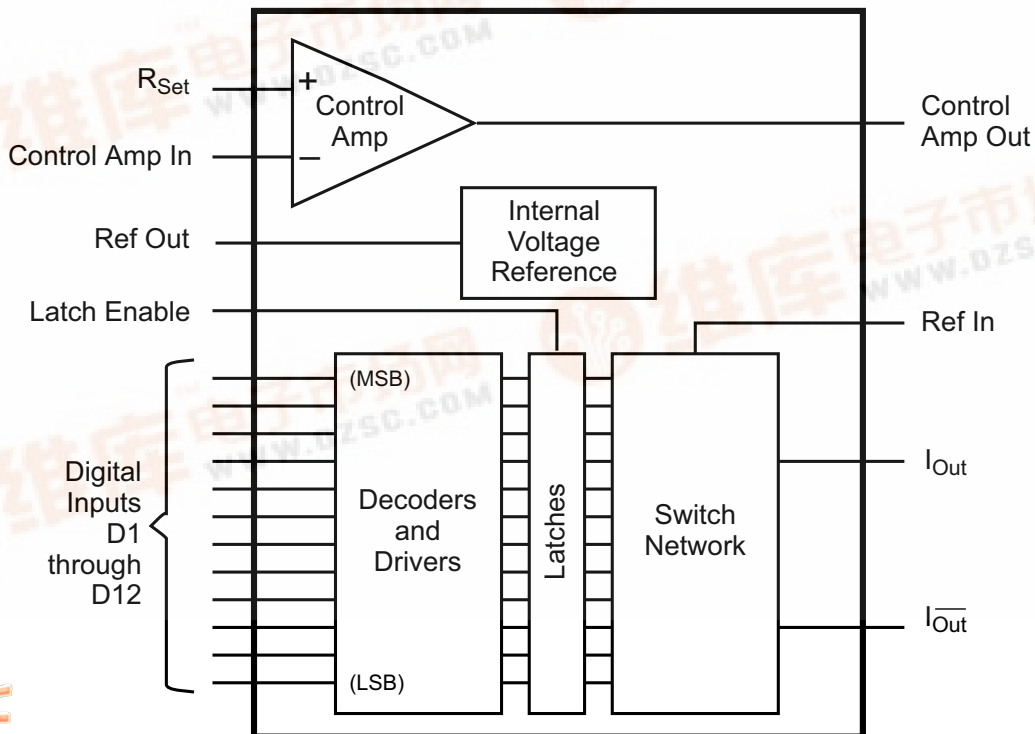

ABSOLUTE MAXIMUM RATINGS (Beyond which damage may occur)¹ 25 °C

Supply Voltages

Positive Supply Voltage (V _{CC})	+7 V
Negative Supply Voltage (V _{EE})	-7 V
A/D Ground Voltage Differential	0.5 V

Input Voltages

Digital Input Voltage (D1–D12, Latch Enable)	0 V to V _{CC}
Control Amp Input Voltage Range	0 V to -4 V
Reference Input Voltage Range (V _{REF})	0 V to V _{EE}

Output Currents

Internal Reference Output Current	500 µA
Control Amplifier Output Current	±2.5 mA

Temperature

Operating Temperature	-40 to +85 °C
Junction Temperature	+150 °C
Lead, Soldering (10 seconds)	+300 °C
Storage	-65 to +150 °C

Note: 1. Operation at any Absolute Maximum Rating is not implied. See Electrical Specifications for proper nominal applied conditions in typical applications.

ELECTRICAL SPECIFICATIONS

T_A = T_{MIN} – T_{MAX}, V_{CC} = +5.0 V, V_{EE} = -5.2 V, R_{Set} = 7.5 kΩ, Control Amp In = Ref Out, V_{OUT} = 0 V, unless otherwise specified.

PARAMETERS	TEST CONDITIONS	TEST LEVEL	SPT9713A			SPT9713B			UNITS
			MIN	TYP	MAX	MIN	TYP	MAX	
DC Performance									
Resolution				12			12		Bits
Differential Linearity		I		±0.5	±0.75		±1.0	±1.25	LSB
Differential Linearity	Max at Full Temp.	VI			±1.5			±2.0	LSB
Integral Linearity	Best Fit	I		±0.75	±1.0		±1.0	±1.5	LSB
Integral Linearity	Max at Full Temp.	VI			±1.75			±2.0	LSB
Output Capacitance	+25 °C	V		10			10		pF
Gain Error ¹	+25 °C	I		1.0	5.0		1.0	5.0	% FS
	Full Temp.	VI			8.0			8.0	% FS
Gain Error Tempco	Full Temp.	V		150			150		PPM/°C
Zero-Scale Offset Error	+25 °C	I		0.5	2.5		0.5	2.5	µA
	Full Temp.	VI			5.0			5.0	µA
Offset Drift Coefficient	Full Temp.	V		0.01			0.01		µA/°C
Output Compliance Voltage	+25 °C	IV	-1.2		+2.0	-1.2		+2.0	V
Equivalent Output Resistance	+25 °C	IV	0.8	1.0	1.2	0.8	1.0	1.2	kΩ
Dynamic Performance									
Conversion Rate	+25 °C	IV	100			100			MWPS
Settling Time t _{ST} ²	+25 °C	V		13			13		ns
Output Propagation Delay t _D ³	+25 °C	V		2			2		ns
Glitch Energy ⁴	+25 °C	V		15			15		pV-s
Full Scale Output Current ⁵	+25 °C	V		20.48			20.48		mA
Spurious-Free Dynamic Range ⁶	+25 °C								
1.23 MHz; 10 MWPS	2 MHz Span	V		70			70		dBc
5.055 MHz; 20 MWPS	2 MHz Span	V		68			68		dBc
10.1 MHz; 50 MWPS	2 MHz Span	V		68			68		dBc
16 MHz; 40 MWPS	10 MHz Span	V		68			68		dBc
Rise Time / Fall Time	R _L = 50 Ω	V		2			2		ns

¹Gain is measured as a ratio of the full-scale current to I_{Set}. The ratio is nominally 128.

²Measured as voltage at mid-scale transition to ±0.024%; R_L=50 Ω.

³Measured from the rising edge of Latch Enable to where the output signal has left a 1 LSB error band.

⁴Glitch is measured as the largest single transient.

⁵Calculated using I_{FS} = 128 x (Control Amp In / R_{Set})

⁶SFDR is defined as the difference in signal energy between the fundamental and worst case spurious frequencies in the output spectrum window, which is centered at the fundamental frequency and covers the indicated span.

ELECTRICAL SPECIFICATIONS

$T_A = T_{MIN} - T_{MAX}$, $V_{CC} = +5.0\text{ V}$, $V_{EE} = -5.2\text{ V}$, $R_{SET} = 7.5\text{ k}\Omega$, Control Amp In = Ref Out, $V_{OUT} = 0\text{ V}$, unless otherwise specified.

PARAMETERS	TEST CONDITIONS	TEST LEVEL	SPT9713A			SPT9713B			UNITS
			MIN	TYP	MAX	MIN	TYP	MAX	
Power Supply Requirements									
Positive Supply Voltage		IV	4.75	5.0	+5.25	4.75	5.0	+5.25	V
Negative Supply Voltage		IV	-5.46	-5.2	-4.94	-5.46	-5.2	-4.94	V
Positive Supply Current (+5.0 V)	+25 °C	I		8	14		8	14	mA
	Full Temp.	VI			16			16	mA
Negative Supply Current (-5.2 V)	+25 °C	I		115	140		115	140	mA
	Full Temp.	VI			148			148	mA
Nominal Power Dissipation		V		640			640		mW
Power Supply Rejection Ratio	$\pm 5\%$ of V_{EE} and V_{CC} External Ref, +25 °C	I		30	100		30	100	$\mu\text{A/V}$
Voltage Input and Control									
Reference Input Impedance	+25 °C	V		3			3		k Ω
Ref. Multiplying Bandwidth	+25 °C	V		40			40		MHz
Internal Reference Voltage		VI	-1.15	-1.20	-1.25	-1.15	-1.20	-1.25	V
Internal Reference Voltage Drift	Full	V		50			50		ppm/°C
Amplifier Input Impedance	+25 °C	V		3			3		M Ω
Amplifier Input Bandwidth	+25 °C	V		1			1		MHz
Digital Inputs									
Logic 1 Voltage	Full Temp.	VI	2.0			2.0			V
Logic 0 Voltage	Full Temp.	VI			0.8			0.8	V
Logic 1 Current	Full Temp.	VI			20			20	μA
Logic 0 Current	Full Temp.	VI			600			600	μA
Input Capacitance	+25 °C	V		3			3		pF
Input Setup Time – t_S	+25 °C	IV	3	2		3	2		ns
Input Setup Time – t_S	Full Temp.	IV	3.5			3.5			ns
Input Hold Time – t_H	+25 °C	IV	0.5	0		0.5	0		ns
Input Hold Time – t_H	Full Temp.	IV	0.5			0.5			ns
Latch Pulse Width – t_{PWL} , t_{PWH}	+25 °C	IV	5.0	4.0		5.0	4.0		ns

TEST LEVEL CODES

All electrical characteristics are subject to the following conditions:

All parameters having min/max specifications are guaranteed. The Test Level column indicates the specific device testing actually performed during production and Quality Assurance inspection. Any blank section in the data column indicates that the specification is not tested at the specified condition.

LEVEL

TEST PROCEDURE

- | | |
|-----|---|
| I | 100% production tested at the specified temperature. |
| II | 100% production tested at $T_A = +25\text{ °C}$, and sample tested at the specified temperatures. |
| III | QA sample tested only at the specified temperatures. |
| IV | Parameter is guaranteed (but not tested) by design and characterization data. |
| V | Parameter is a typical value for information purposes only. |
| VI | 100% production tested at $T_A = +25\text{ °C}$. Parameter is guaranteed over specified temperature range. |

THEORY OF OPERATION

The SPT9713 uses a segmented architecture incorporating most significant bit (MSB) decoding. The four MSBs (D1–D4) are decoded to thermometer code lines to drive 15 discrete current sinks. For the eight least significant bits (LSBs), D5 and D6 are binary weighted and D7–D12 are applied to the R-2R network. The 12-bit decoded data is input to internal master/slave latches. The latched data is input to the switching network and is presented on the output pins as complementary current outputs.

TYPICAL INTERFACE CIRCUIT

The SPT9713 requires few external components to achieve the stated operation and performance. Figure 2 shows the typical interface requirements when using the SPT9713 in normal circuit operation. The following sections provide descriptions of the pin functions and outline critical performance criteria to consider for achieving optimal device performance.

POWER SUPPLIES AND GROUNDING

The SPT9713 requires the use of +5 V and –5.2 V supplies. All supplies should be treated as analog supply sources. This means the ground returns of the device should be connected to the analog ground plane. All supply pins should be bypassed with .01 μF and 10 μF decoupling capacitors as close to the device as possible.

The two grounds available on the SPT9713 are DGND and AGND. These grounds are not tied together internal to the device. The use of ground planes is recommended to achieve the best performance of the SPT9713. All ground, reference and analog output pins should be tied directly to the DAC ground plane. The DAC and system ground planes should be separate from each other and only connected at a single point through a ferrite bead to reduce ground noise pickup.

DIGITAL INPUTS AND TIMING

The SPT9713 uses TTL logic drivers for each data input D1–D12 and Latch Enable. It also employs master/slave latches to simplify digital interface timing requirements and reduce glitch energy by synchronizing the current switches. This is an improvement over the AD9713, which typically requires external latches for digital input synchronization.

Referring to figure 1, data is latched into the DAC on the rising edge of the latch enable clock with the associated setup and hold times. The output transition occurs after a typical 2 ns propagation delay and settles to within ± 1 LSB in typically 13 ns. Because of the SPT9713's rising-edge triggering, no timing changes are required when replacing an AD9713 operating in the transparent mode.

VOLTAGE REFERENCE

When using the internal reference, Ref Out should be connected to Control Amp In and decoupled with a 0.1 μF capacitor. Control Amp Out should be connected to Ref In and decoupled to the analog supply. (See figure 2.)

Full-scale output current is determined by Control Amp In and R_{Set} using the following formula:

$$I_{\text{Out}}(\text{FS}) = (\text{Control Amp In} / R_{\text{Set}}) \times 128$$

(Current Out is a constant 128 factor of the reference current)

The internal reference is typically –1.20 V with a tolerance of ± 0.05 V and a typical drift of 50 ppm/ $^{\circ}\text{C}$. If greater accuracy or temperature stability is required, an external reference can be utilized.

OUTPUTS

The output of the SPT9713 is comprised of complementary current sinks, I_{Out} and $\overline{I_{\text{Out}}}$. The output current levels at either I_{Out} or $\overline{I_{\text{Out}}}$ are based upon the digital input code. The sum of the two is always equal to the full-scale output current minus one LSB.

By terminating the output current through a resistive load to ground, an associated voltage develops. The effective resistive load (R_{Eff}) is the output resistance of the device (R_{Out}) in parallel with the resistive load (R_{L}). The voltage which develops can be determined using the following formulas:

$$\begin{aligned} \text{Control Amp Out} &= -1.2 \text{ V, and } R_{\text{Set}} = 7.5 \text{ k}\Omega \\ I_{\text{Out}}(\text{FS}) &= (-1.2 \text{ V} / 7.5 \text{ k}\Omega) \times 128 = -20.48 \text{ mA} \\ R_{\text{L}} &= 51 \Omega \\ R_{\text{Out}} &= 1.0 \text{ k}\Omega \\ R_{\text{Eff}} &= 51 \Omega \parallel 1.0 \text{ k}\Omega = 48.52 \Omega \\ V_{\text{Out}} &= R_{\text{Eff}} \times I_{\text{Out}}(\text{FS}) = 48.52 \Omega \times -20.48 \text{ mA} \\ &= -0.994 \text{ V} \end{aligned}$$

The resistive load of the SPT9713 can be modified to incorporate a wide variety of signal levels. However, optimal device performance is achieved when the outputs are equivalently loaded.

Figure 1 – Timing Diagram

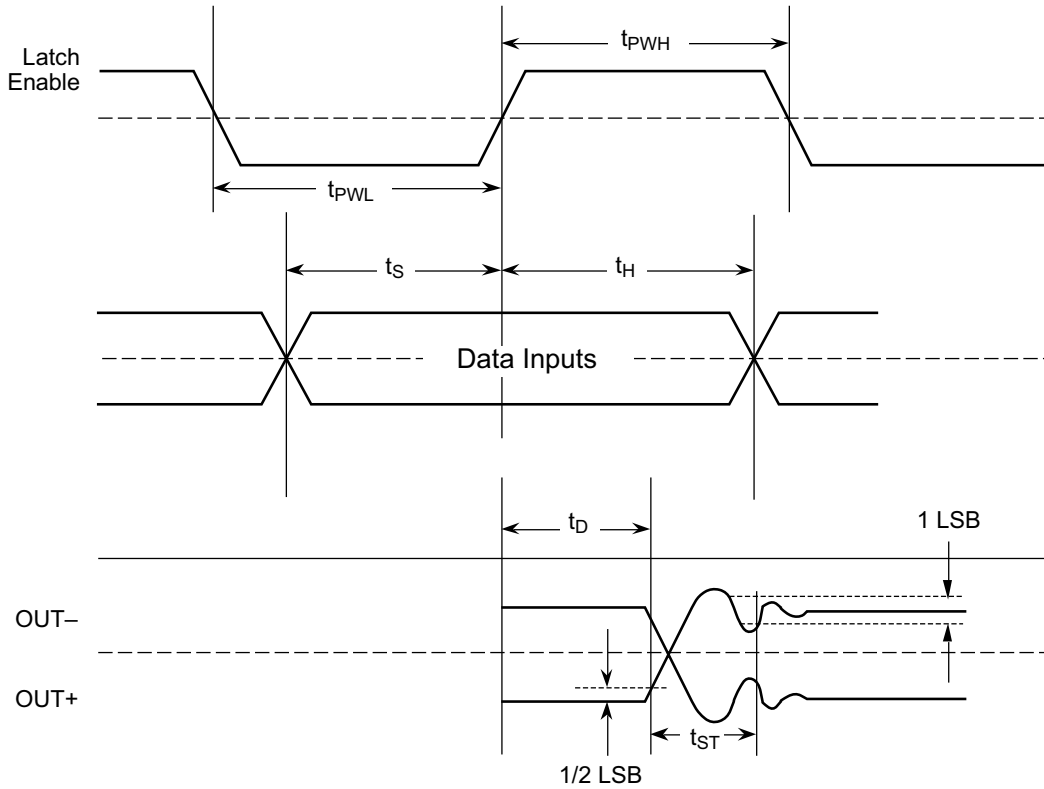
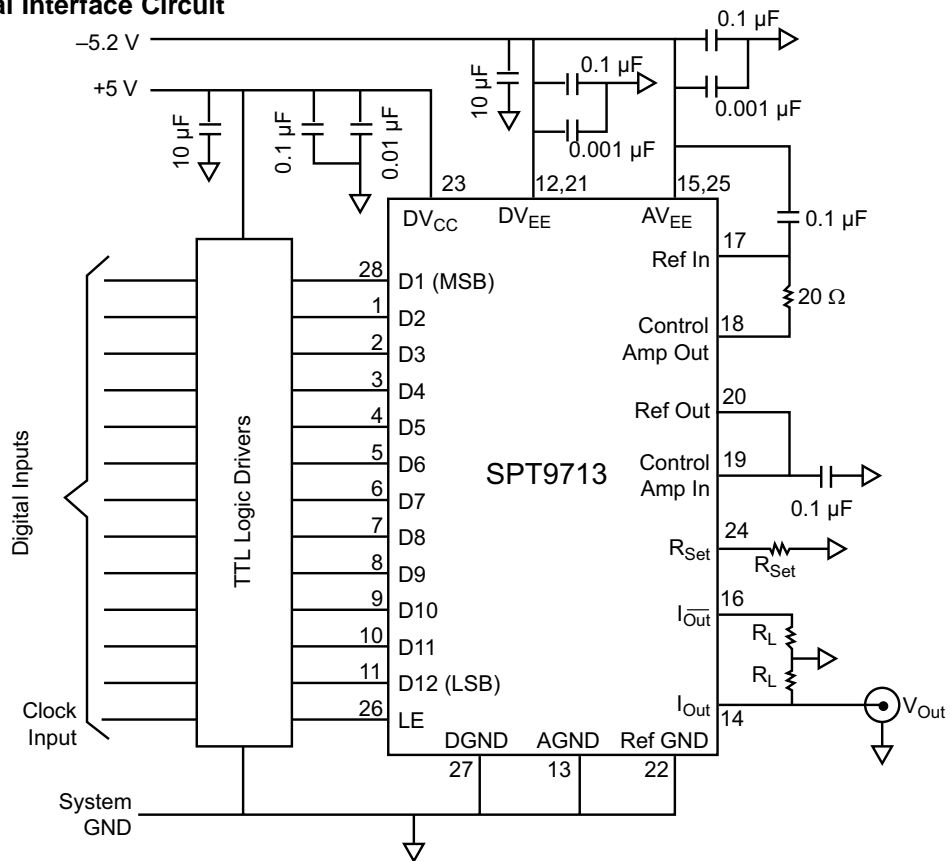
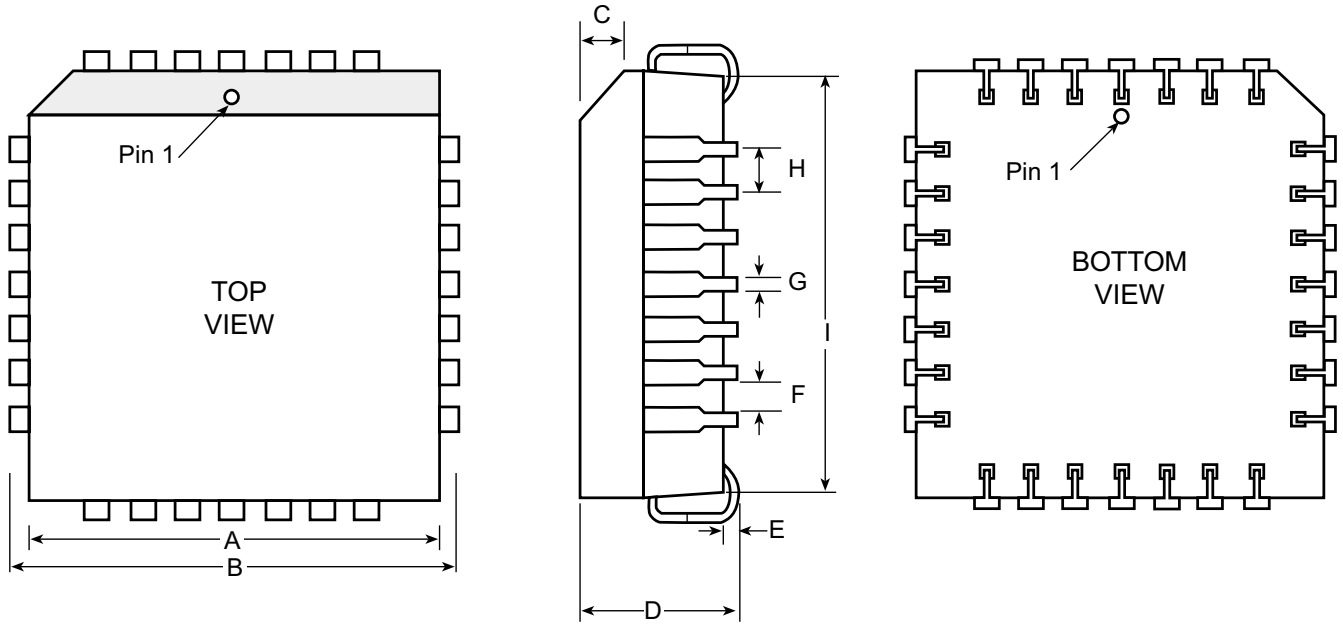

Figure 2 – Typical Interface Circuit



PACKAGE OUTLINE

28-Lead PLCC



SYMBOL	INCHES		MILLIMETERS	
	MIN	MAX	MIN	MAX
A	0.452	0.456	11.48	11.58
B	0.485	0.495	12.32	12.57
C	30°		30°	
D	0.170	0.179	4.32	4.55
E	0.020	0.025	0.51	0.64
F	0.031	0.035	0.79	0.89
G	0.013	0.021	0.33	0.53
H	0.048	0.052	1.22	1.32
I	0.410	0.430	10.41	10.92

PIN ASSIGNMENTS

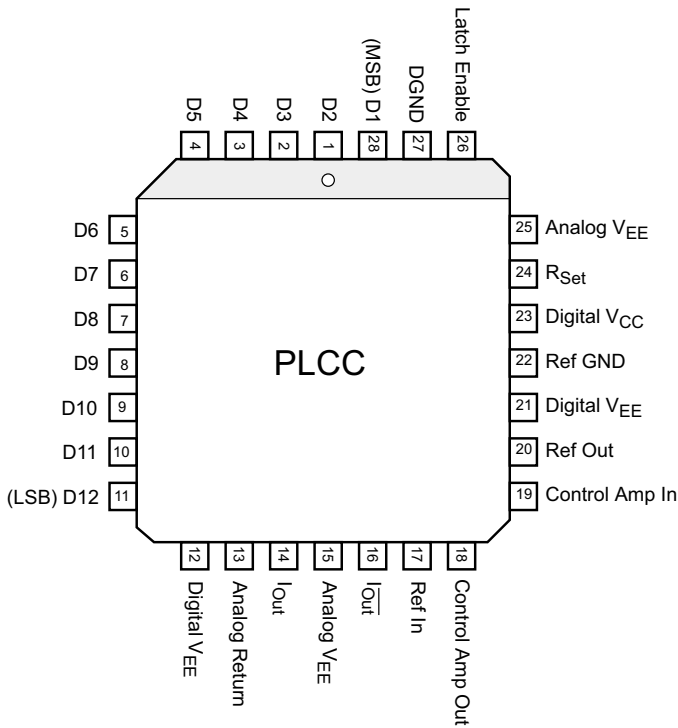

PIN FUNCTIONS

Name	Function
Out+	Analog Current Output
Out-	Complementary Analog Current Output
D1–D12	Digital Input Bits (D12 is the LSB)
Latch Enable	Latch Control Line
Ref In	Voltage Reference Input
Ref Out	Internal Voltage Reference Output Normally Connected to Control Amp In
Ref GND	Ground Return For Internal Voltage Reference and Amplifier
Control Amp In	Normally Connected to Ref Out If Not Connected to External Reference
Control Amp Out	Output of Internal Control Amplifier Normally Connected to Ref In
RSet ¹	Connection for External Resistance Reference When Using Internal Amplifier Nominally 7.5 kΩ
Analog Return	Analog Return Ground
Analog V _{EE}	Analog Negative Supply (–5.2 V)
Digital V _{EE}	Digital Negative Supply (–5.2 V)
Digital V _{CC}	Digital Positive Supply (+5.2 V)
DGND	Digital Ground Return

¹Full-Scale Current Out = 128 (Control Amp In / RSet)

ORDERING INFORMATION

PART NUMBER	DNL/INL	TEMPERATURE RANGE	PACKAGE
SPT9713AIP	±0.75/±1.0	–40 to +85 °C	28L PLCC
SPT9713BIP	±1.25/±1.5	–40 to +85 °C	28L PLCC

DISCLAIMER

FAIRCHILD SEMICONDUCTOR RESERVES THE RIGHT TO MAKE CHANGES WITHOUT FURTHER NOTICE TO ANY PRODUCTS HEREIN TO IMPROVE RELIABILITY, FUNCTION OR DESIGN. FAIRCHILD DOES NOT ASSUME ANY LIABILITY ARISING OUT OF THE APPLICATION OR USE OF ANY PRODUCT OR CIRCUIT DESCRIBED HEREIN; NEITHER DOES IT CONVEY ANY LICENSE UNDER ITS PATENT RIGHTS, NOR THE RIGHTS OF OTHERS.

LIFE SUPPORT POLICY

FAIRCHILD'S PRODUCTS ARE NOT AUTHORIZED FOR USE AS CRITICAL COMPONENTS IN LIFE SUPPORT DEVICES OR SYSTEMS WITHOUT THE EXPRESS WRITTEN APPROVAL OF THE PRESIDENT OF FAIRCHILD SEMICONDUCTOR CORPORATION. As used herein:

1. Life support devices or systems are devices or systems which, (a) are intended for surgical implant into the body, or (b) support or sustain life, and whose failure to perform, when properly used in accordance with instructions for use provided in the labeling, can be reasonably expected to result in a significant injury to the user.
2. A critical component is any component of a life support device or system whose failure to perform can be reasonably expected to cause the failure of the life support device or system, or to affect its safety or effectiveness.