



# SR5311-V / SR5311-V(B)

High Brightness LED Lamp

## Features

- Colorless transparency lens type
- $\phi 5\text{mm}$ (T-13/4) all plastic mold type
- High luminosity

## Outline Dimensions

unit : mm

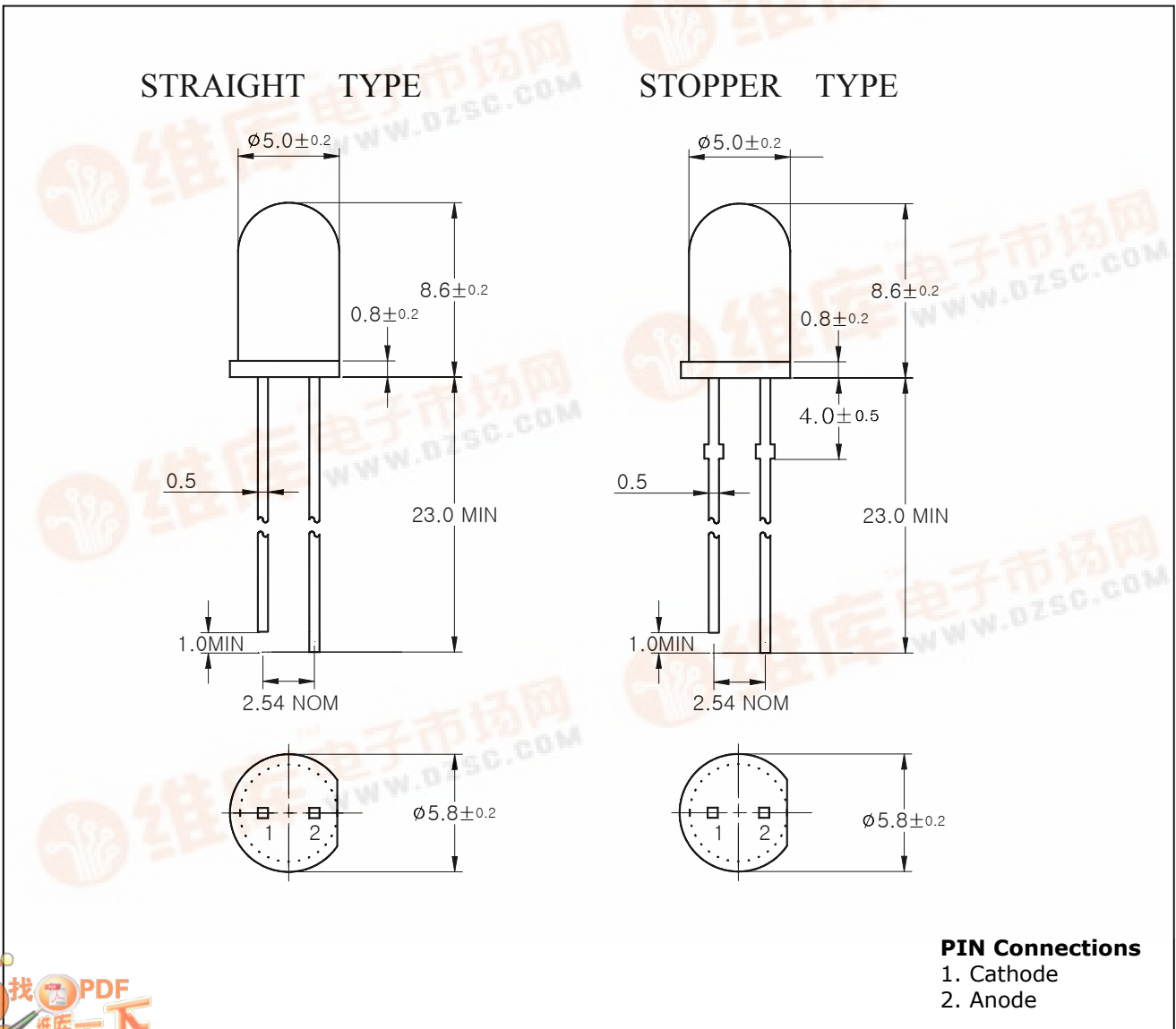

## Absolute maximum ratings

Characteristic	Symbol	Ratings	Unit
Power Dissipation	$P_D$	70	mW
Forward Current	$I_F$	30	mA
* <sup>1</sup> Peak Forward Current	$I_{FP}$	50	mA
Reverse Voltage	$V_R$	4	V
Operating Temperature	$T_{opr}$	-20 ~ 85	°C
Storage Temperature	$T_{stg}$	-30 ~ 100	°C
* <sup>2</sup> Soldering Temperature	$T_{sol}$	260°C for 5 seconds	

\*1. Duty ratio = 1/16, Pulse width = 0.1ms

\*2. Keep the distance more than 2.0mm from PCB to the bottom of LED package

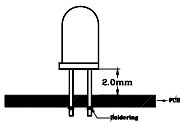

## Electrical Characteristics

Characteristic	Symbol	Test Condition	Min.	Typ.	Max.	Unit
Forward Voltage	$V_F$	$I_F = 20\text{mA}$	-	1.8	2.5	V
* <sup>3</sup> Luminous Intensity	$I_V$	$I_F = 20\text{mA}$	230	505	780	mcd
Peak Wavelength	$\lambda_P$	$I_F = 20\text{mA}$	-	660	-	nm
Spectrum Bandwidth	$\Delta \lambda$	$I_F = 20\text{mA}$	-	20	-	nm
Reverse Current	$I_R$	$V_R = 4\text{V}$	-	-	10	uA
* <sup>4</sup> Half Angle	$\theta_{1/2}$	$I_F = 20\text{mA}$	-	±11	-	deg

\*3. Luminous Intensity Maximum tolerance for each Grade Classification limit is ±18%

\*3. Luminous Intensity classification

N	O	P
230~350	350~520	520~780

\*4.  $\theta_{1/2}$  is the off-axis angle where the luminous intensity is 1/2 the peak intensity

Characteristic Diagrams

Fig. 1  $I_F - V_F$

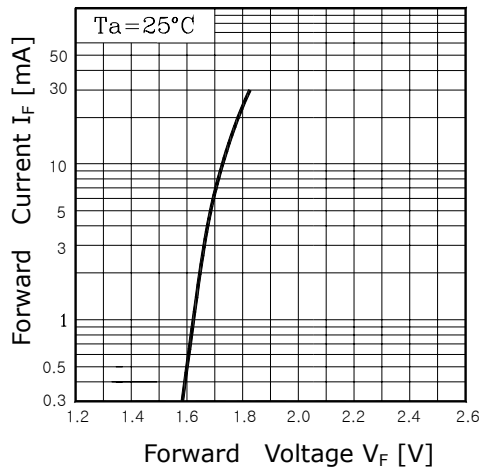

Fig. 2  $I_V - I_F$

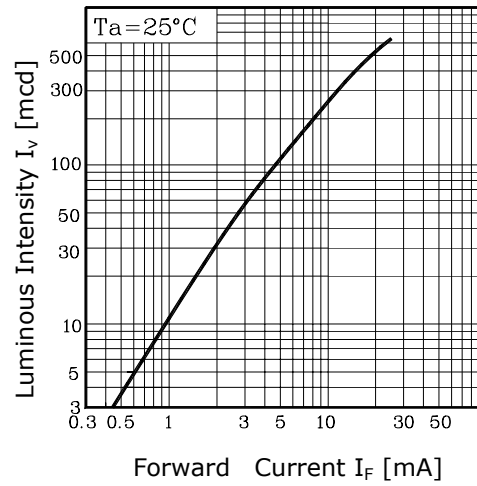

Fig. 3  $I_F - T_a$

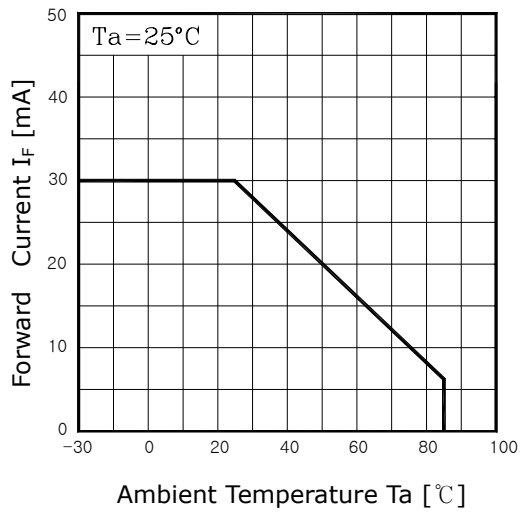

Fig. 4 Spectrum Distribution

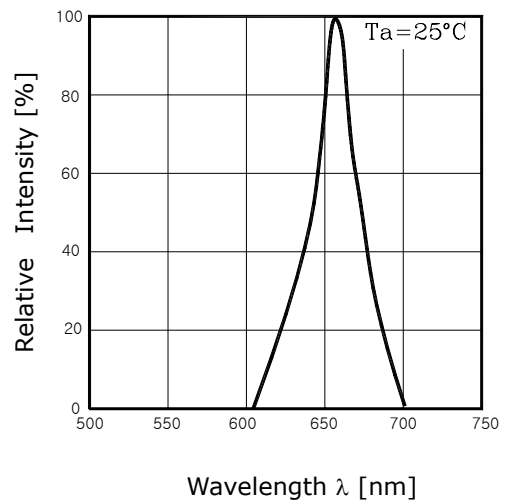

Fig. 5 Radiation Diagram

