



SRA2210

PNP Silicon Transistor

Descriptions

- Switching application
- Interface circuit and driver circuit application

Features

- With built-in bias resistors
- Simplify circuit design
- Reduce a quantity of parts and manufacturing process
- High packing density

Ordering Information

Type NO.	Marking	Package Code
SRA2210	SRA2210	TO-92

Outline Dimensions

unit : mm

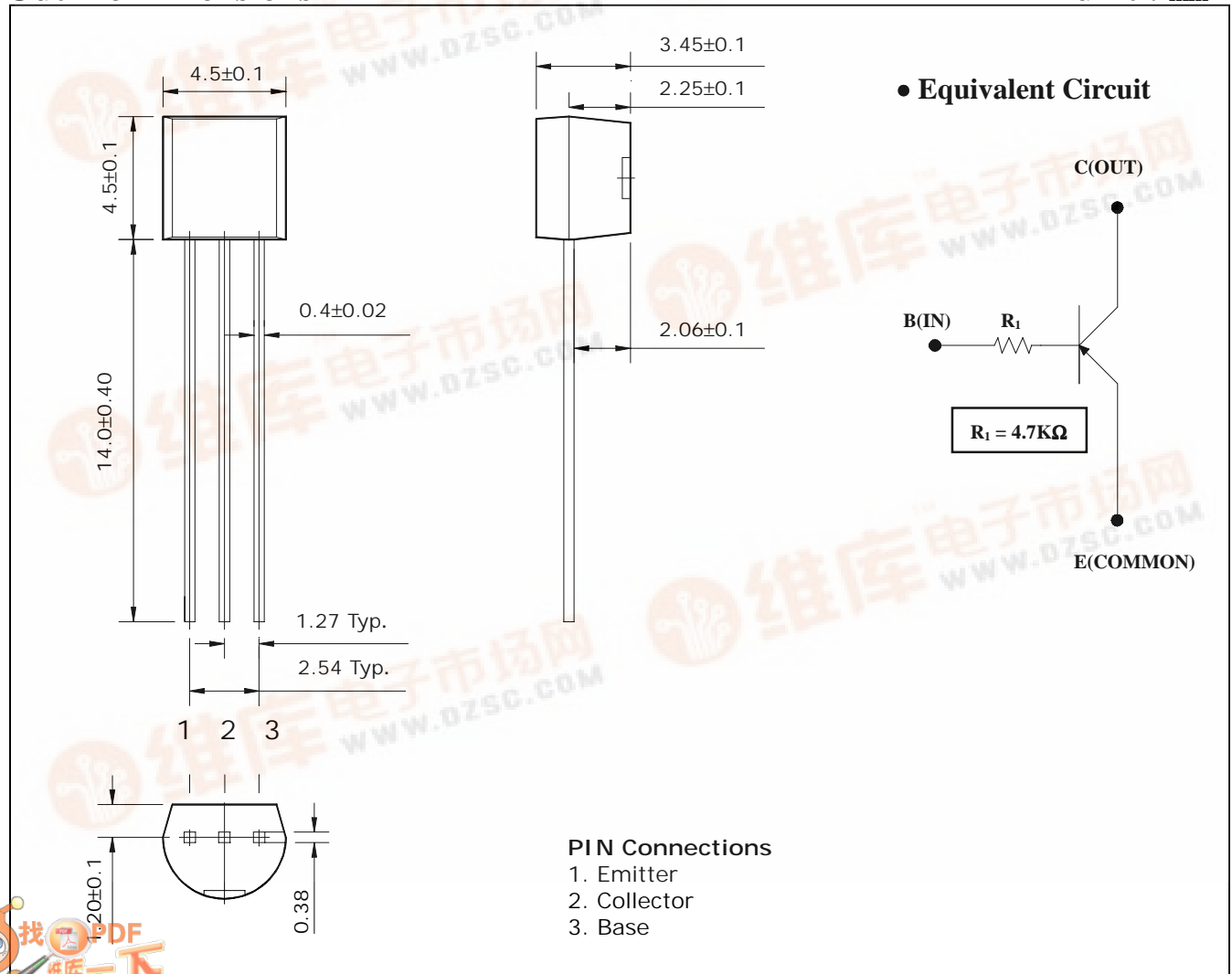

Absolute maximum ratings

(Ta=25°C)

Characteristic	Symbol	Ratings	Unit
Collector-Base Voltage	V_{CBO}	-50	V
Collector-Emitter Voltage	V_{CEO}	-50	V
Emitter-Base Voltage	V_{EBO}	-5	V
Collector Current	I_C	-100	mA
Power Dissipation	P_D	625	mW
Junction Temperature	T_J	150	°C
Storage Temperature	T_{STG}	-55 ~ 150	°C

Electrical Characteristics

(Ta=25°C)

Characteristic	Symbol	Test Condition	Min.	Typ.	Max.	Unit
Collector Cut-off Current	I_{CBO}	$V_{CB} = -50V, I_E = 0$	-	-	-500	nA
Emitter Cut-off Current	I_{EBO}	$V_{EB} = -5V, I_C = 0$	-	-	-500	nA
DC Current Gain	h_{FE}	$V_{CE} = -5V, I_C = -1mA$	120	-	-	-
Collector-Emitter Saturation Voltage	$V_{CE(SAT)}$	$I_C = -10mA, I_B = -0.5mA$	-	-0.1	-0.3	V
Transition Frequency	f_T^*	$V_{CE} = -10V, I_C = -5mA$	-	250	-	MHz
Input Resistance	R_1	-	-	4.7	-	KΩ

* : Characteristic of Transistor Only

Electrical Characteristic Curves

Fig. 1 $h_{FE} - I_C$

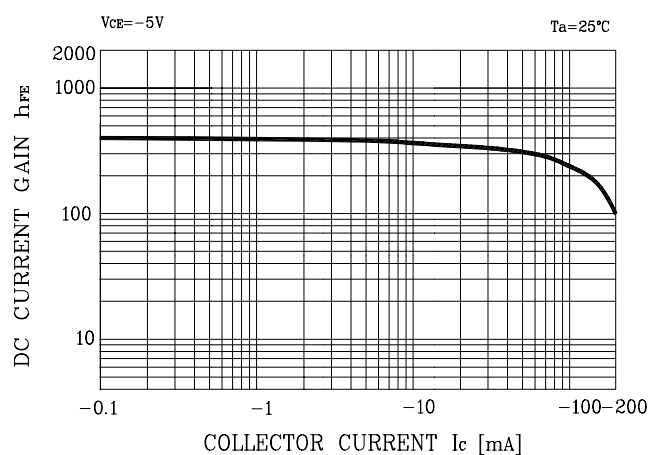

Fig. 2 $V_{CE(SAT)} - I_C$

