

[SmartHeat®](#)

Hand Soldering

[SMT Rework](#)

[Desoldering](#)

[BGA Rework](#)

[CSP Rework](#)

[Fume Extraction](#)

[Fluid Dispensing](#)

[Terms & Conditions](#)

[metcal](#) > [products](#) > [hand soldering](#) > [SP200 system](#) > **SSC tips**

Selecting an SSC tip cartridge

Each Metcal tip cartridge is designed for high power delivery, so you can often solder 100°F or more lower than with a conventional iron. For most applications, a 600 Series tip cartridge will provide enough power and flexibility to do the job. Switch to a 700 Series only where absolutely necessary; for example, when working with heavy ground planes. When working with no-cleans or thermally sensitive applications, Metcal's 500 Series tip cartridges are an excellent choice.

x= 5 for 500 Series, 6 for 600 Series, and 7 for 700 Series.

Tip Geometry

For maximum performance, pick a tip geometry which will maximize contact with the connection. A flat, blunt tip will transfer more heat than a fine, pointed one. Choosing the largest tip possible will improve performance (enabling you to conduct more heat at lower temperatures), and enhance tip life.

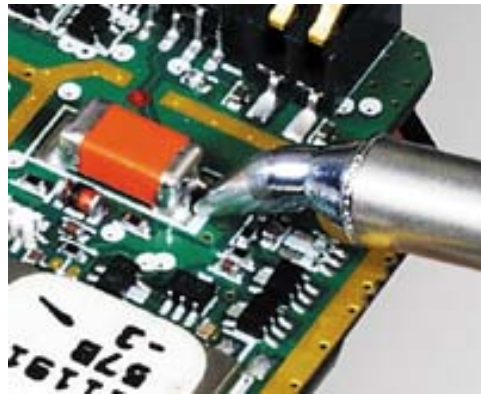

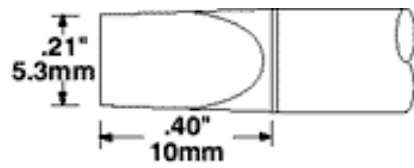

SSC-X17A
Extra Large Chisel
.21" (5.3mm)

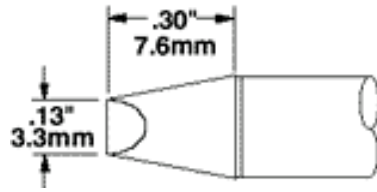

SSC-X13A
Chisel 90°
.13" (3.3mm)

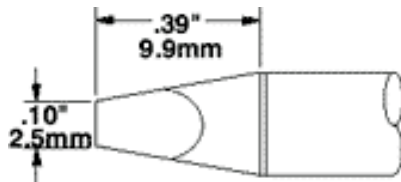

SSC-X36A
Chisel 30°
.10" (2.5mm)

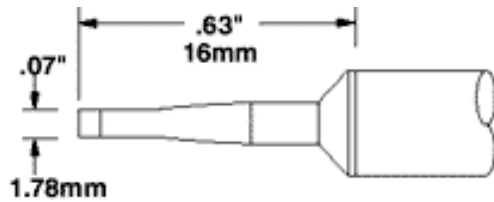

SSC-X42A
Long Reach Chisel 60°
.07" (1.78mm)

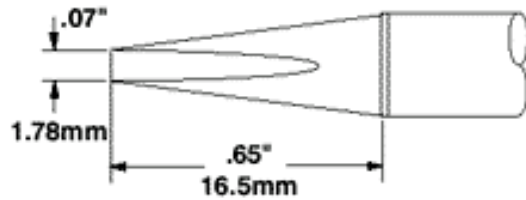

SSC-X70A
Long Chisel
.07" (1.78mm)

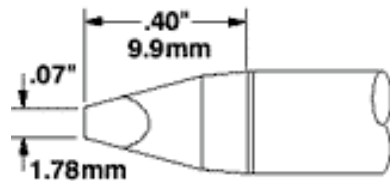

SSC-X37A
Chisel 30°
.07" (1.78mm)

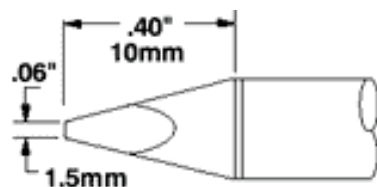

SSC-X38A
Chisel 30°
.06" (1.5mm)

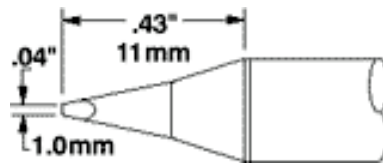

SSC-X25A

Chisel 30°
.04" (1.0mm)

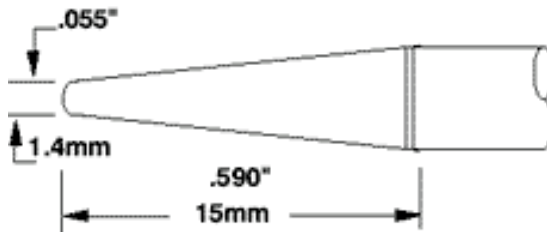

SSC-X74A

Conical Sharp
.055" (1.4mm)

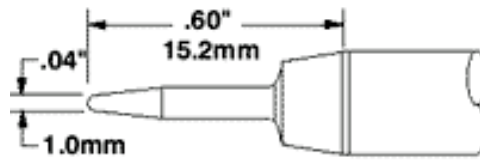

SSC-X01A

Conical Sharp
.04" (1.0mm)

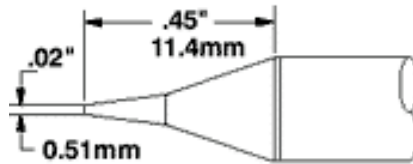

SSC-X22A

Conical Sharp
.02" (0.51mm)

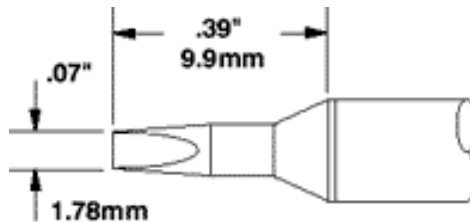

SSC-X72A

Conical Chisel
.07" (1.78mm)

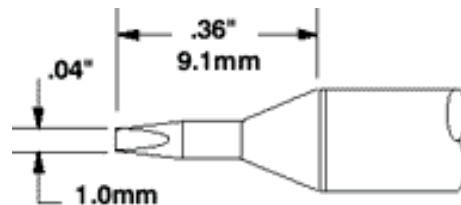

SSC-X71A

Conical Chisel
.04" (1.0mm)

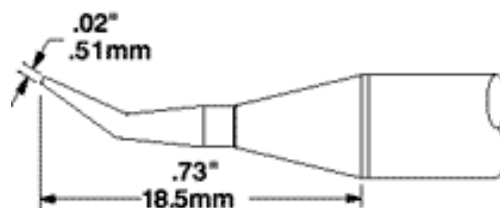

SSC-X54A

Sharp Bent 30°
.02" (0.51mm)

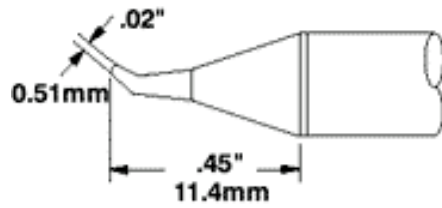

SSC-X26A
Sharp Bent 30°
.02" (0.51mm)

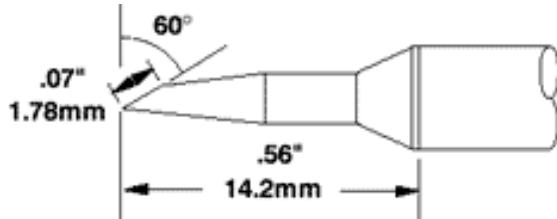

SSC-X47A
Bevel 60°
.07" (1.78mm)

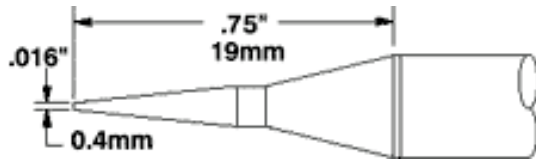

SSC-X45A
Bevel 60°
.016" (0.4mm)

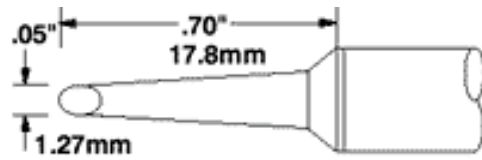

SSC-X67A
Drag Soldering Tip
(Mini-Hoof)

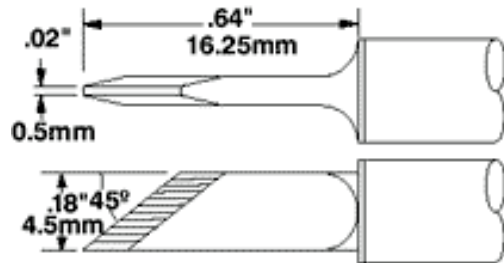

SSC-X61A
Drag Soldering Tip
(Knife)

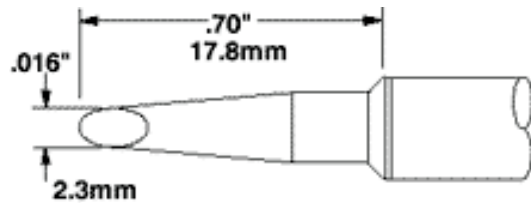

SSC-X39A
Drag Soldering Tip
(Hoof)

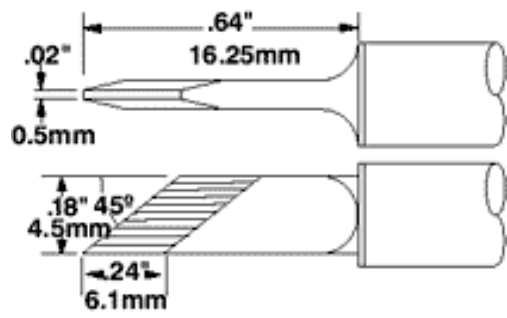

SSC-X73A
Drag Soldering Tip
(Increased Tinned
Area, .24~ 6.1mm)

500 series x=5 600 series x=6 700 series x=7

[Top](#)