



CS-5.1[®] Decoder 5.1-Channel Soundfield Generator

SSM2005

FEATURES

- Generates 5.1-Channel Soundfield from All Stereo Sources
- No Pre-Encoding Required
- Excellent Decoding of Pre-Encoded Sources
- 4- or 5-Speaker Operation
- Subwoofer Output
- Full Bandwidth on All Channels
- Optimized Modes for Video and Music
- Excellent Surround Image at All Positions
- Independent Left and Right Surround Steering
- No Surround Channel Delay Required
- Built-In White Noise Generator

APPLICATIONS

- Home Theater Receivers
- VCD/DVD Players
- Auto Sound Receivers and Amplifiers
- Surround Sound Decoders
- Karaoke
- Computer Audio Boards
- Video Games

GENERAL DESCRIPTION

The SSM2005 Circle Surround[®] decoder produces true 5.1-channel surround soundfield from any stereo source, including VCD, DVD, VCR, CD and FM stereo broadcasts. The SSM2005 is also compatible with encoded sources, such as Dolby ProLogic[®] and Circle Surround encoded movies and music. External delays and noise reduction processors are not required for the surround channels.

Circle Surround encoded stereo signals will produce a full 360° soundfield when played through the SSM2005. Recording engineers can encode sounds to any of the five speakers surrounding the listener. Left Front, Right Front, Center, and differentiated Left and Right surround channels are generated, providing a realistic ambiance effect with either 4- or 5-speaker configurations.

The SSM2005 is available from Analog Devices, subject to the License and Royalty requirements as described on the following page of the data sheet.

PIN CONFIGURATIONS

48-Lead SSOP
(RS Suffix)

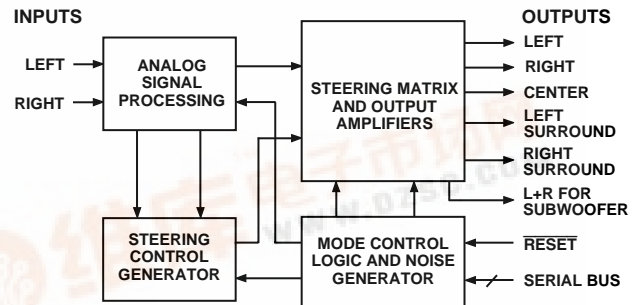
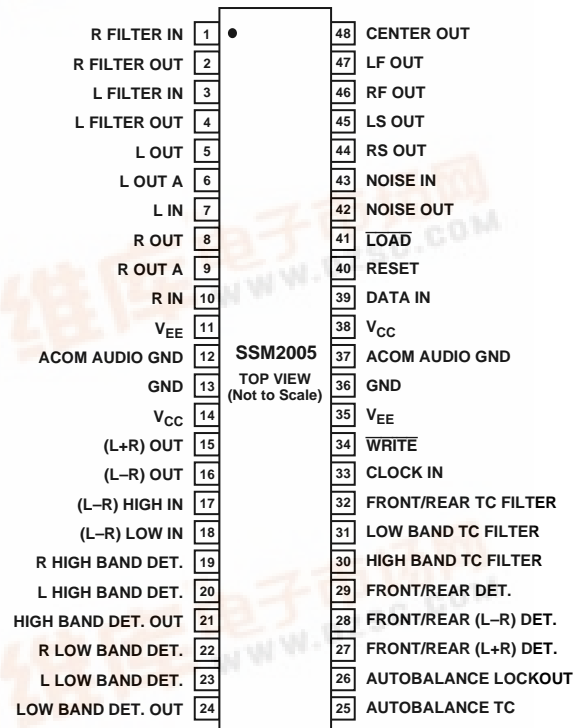

Figure 1. Simplified Block Diagram

CS-5.1 and CS are registered trademarks of SRS Labs, Inc. and ValenceTechnology Ltd.

Circle Surround is a registered trademark of SRS Labs, Inc. and Valence Technology Ltd.

Dolby ProLogic is a registered trademark of Dolby Laboratories Licensing Corporation, San Francisco, California.

Circle Surround technology is protected under one or more of the following U.S. Patents and corresponding patents worldwide: 5,319,713; 5,333,201; 5,638,452; 5,771,295.

REV. 0

Information furnished by Analog Devices is believed to be accurate and reliable. However, no responsibility is assumed by Analog Devices for its use, nor for any infringements of patents or other rights of third parties which may result from its use. No license is granted by implication or otherwise under any patent or patent rights of Analog Devices.

One Technology Way, P.O. Box 9106, Norwood, MA 02062-9106, U.S.A.

Tel: 781/329-4700

World Wide Web Site: <http://www.analog.com>

Fax: 781/326-8702

© Analog Devices, Inc. 1998

SSM2005—SPECIFICATIONS

ELECTRICAL CHARACTERISTICS ($V_S = \pm 6.0\text{ V}$, $T_A = +25^\circ\text{C}$, $f = 2\text{ kHz}$, Modes: Video, 5-2-5, Center On, Sound Spread Off, Autobalance Off, Noise Off)

Parameter	Symbol	Conditions	Min	Typ	Max	Units
INPUT CHARACTERISTICS						
Level ¹	V_L, V_R	$Z_{SOURCE} < 10\ \Omega$		0		dBd
Input Impedance	Z_{IN}	L and R Inputs		10		k Ω
OUTPUT CHARACTERISTICS						
Level						
Left Front		$L_T = 0\text{ dBd}$, $R_T = \text{Off}$		0		dBd
Right Front		$R_T = 0\text{ dBd}$, $L_T = \text{Off}$		0		dBd
Center		$L_T = R_T = 0\text{ dBd}$, In Phase, Video Mode		+6		dBd
Left Rear, Right Rear		$L_T = R_T = 0\text{ dBd}$, Out of Phase		+3		dBd
Channel Separation						
Left Front and Right Front / Center		$L_T = R_T$, In Phase, Video Mode		30		dBd
Left Rear and Right Rear / Center		$L_T = R_T$, Out of Phase		40		dBd
Left Rear, Left Front		$L_T = R_T$, Out of Phase		30		dBd
Left Rear, Right Rear		$L_T = R_T$, Out of Phase		30		dBd
Output Impedance	Z_{OUT}			10		Ω
DYNAMIC PERFORMANCE						
Total Harmonic Distortion + Noise	THD+N	All Channels		0.04		%
Signal-to-Noise Ratio	SNR			88		dB
Dynamic Range, Output	DR	Noise Floor to 1% THD		100		dB
Headroom	HR	All Channels		12		dB
NOISE GENERATOR						
Output Level ²		Noise Mode On, A-Weighted		-10		dBd
Matching		All Channels		0.5	1.5	dB
AUTOBALANCE						
Capture Range		$ V_H - V_L $		± 4		dB
Capture Time		$V_L = V_R > -10\text{ dBd}$, $ V_{LEFT} - V_{RIGHT} < 3\text{ dB}$		5		s
CONTROL LOGIC						
Logic Thresholds		Logic Levels Referenced to ACOM				
High (1)			2.4			V
Low (0)					0.8	V
Input Current				1		μA
Timing Characteristics		See Timing Diagrams				
POWER SUPPLIES						
Operating Voltage Range ³	V_S	Single Supply	+10		+12	V
	$+V_S, -V_S$	Dual Supply	± 5		± 6	V
Current	I_S	$V_L = V_R = \text{ACOM}$, $V_S = 12\text{ V}$		18	30	mA

NOTES

¹0 dBd = 300 mV rms

²With filter shown in Figure 8.

³Specifications apply for $V_S = \pm 6\text{ V}$.

Specifications subject to change without notice.

LICENSING INFORMATION

The CIRCLE SURROUND® TECHNOLOGY rights incorporated in the SSM2005 are owned by SRS Labs, Inc. and by Valence Technology Ltd., and licensed to Analog Devices, Inc.

Users of any SSM2005 Circle Surround decoder must first sign a free use license to purchase OEM quantities for consumer electronics applications which may be granted upon submission of a preproduction sample to, and the satisfactory passing of performance verification tests performed by SRS Labs, Inc. or Valence Technology Ltd. SRS Labs, Inc. and Valence Technology Ltd. reserve the right to decline a use license for any submission that does not pass performance specifications or is not in the consumer electronics classification.

All equipment manufactured using any SSM2005 Circle Surround decoder must carry the Circle Surround logo on the front panel in a manner approved in writing by SRS Labs, Inc. or Valence Technology Ltd. If the Circle Surround logo is printed in users manuals, service manuals or advertisements, it must appear in a form approved in writing by SRS Labs, Inc. or Valence Technology Ltd. The rear panel of Circle Surround products, users manuals, service manuals, and all advertisements must all carry the Circle Surround legend as specified in the Circle Surround trademark manual published by SRS Labs, Inc. and Valence Technology Ltd.

SSM2005

ABSOLUTE MAXIMUM RATINGS*

Supply Voltage, V_S	± 8 V or +16 V
Logic Inputs	V_S
Storage Temperature Range	-65°C to $+150^{\circ}\text{C}$
Operating Temperature Range	-20°C to $+70^{\circ}\text{C}$
Junction Temperature Range	$+150^{\circ}\text{C}$
Lead Temperature Range (Soldering, 60 sec)	$+300^{\circ}\text{C}$

*Stresses above those listed under Absolute Maximum Ratings may cause permanent damage to the device. This is a stress rating only; functional operation of the device at these or any other conditions above those listed in the operational sections of this specification is not implied. Exposure to absolute maximum rating conditions for extended periods may affect device reliability.

Package Type	θ_{JA}^1	θ_{JC}	Units
48-Lead SSOP (RS)	100	50	$^{\circ}\text{C}/\text{W}$

NOTE
¹ θ_{JA} is specified for worst case conditions.

ORDERING GUIDE

Model	Temperature Range	Package Description	Package Option
SSM2005RS-Reel	-20°C to $+70^{\circ}\text{C}$	48-Lead SSOP	RS-48

CAUTION

ESD (electrostatic discharge) sensitive device. Electrostatic charges as high as 4000 V readily accumulate on the human body and test equipment and can discharge without detection. Although the SSM2005 features proprietary ESD protection circuitry, permanent damage may occur on devices subjected to high energy electrostatic discharges. Therefore, proper ESD precautions are recommended to avoid performance degradation or loss of functionality.



SSM2005 – Typical Performance Characteristics

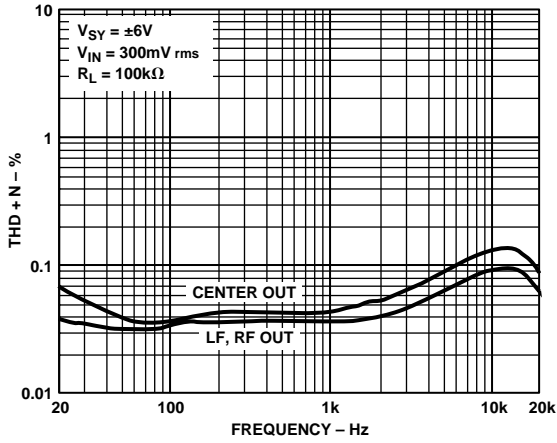

Figure 2. THD + N vs. Frequency; Front Channels

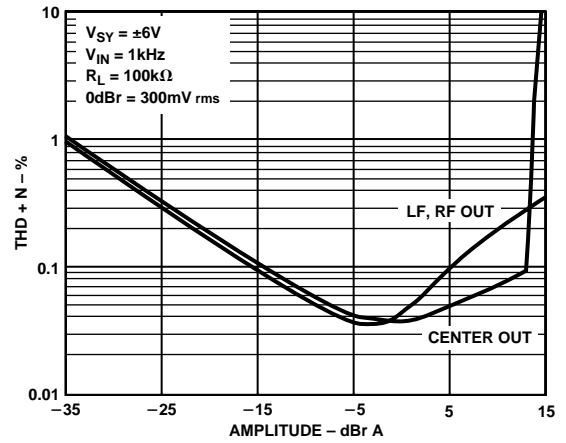

Figure 4. THD + N vs. Amplitude; Front Channels

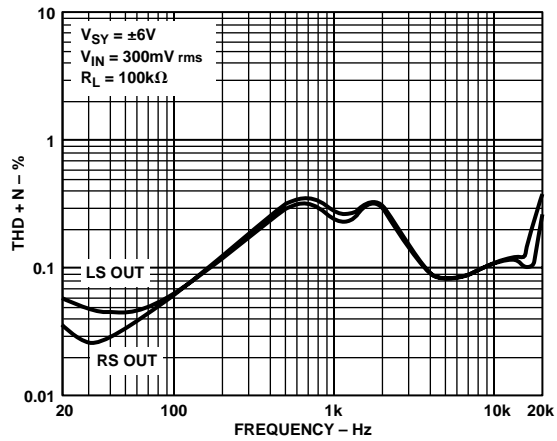

Figure 3. THD + N vs. Frequency; Surround Channels

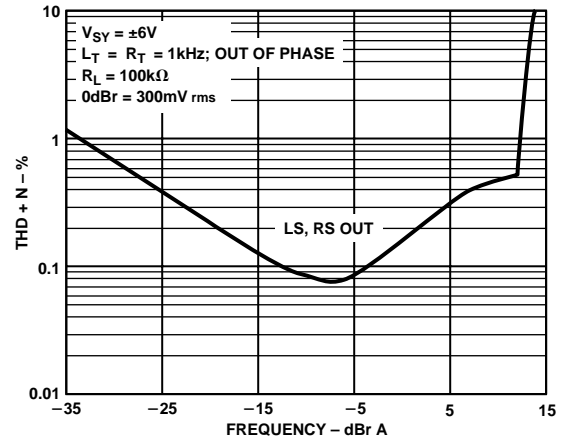

Figure 5. THD + N vs. Frequency; Surround Channels

PIN CONFIGURATIONS

48-Lead SSOP
(RS Suffix)

R FILTER IN	1	SSM2005 TOP VIEW (Not to Scale)	48	CENTER OUT
R FILTER OUT	2		47	LF OUT
L FILTER IN	3		46	RF OUT
L FILTER OUT	4		45	LS OUT
L OUT	5		44	RS OUT
L OUT A	6		43	NOISE IN
L IN	7		42	NOISE OUT
R OUT	8		41	LOAD
R OUT A	9		40	RESET
R IN	10		39	DATA IN
V _{EE}	11		38	V _{CC}
ACOM AUDIO GND	12		37	ACOM AUDIO GND
GND	13		36	GND
V _{CC}	14		35	V _{EE}
(L+R) OUT	15		34	WRITE
(L-R) OUT	16		33	CLOCK IN
(L-R) HIGH IN	17		32	FRONT/REAR TC FILTER
(L-R) LOW IN	18		31	LOW BAND TC FILTER
R HIGH BAND DET.	19		30	HIGH BAND TC FILTER
L HIGH BAND DET.	20		29	FRONT/REAR DET.
HIGH BAND DET. OUT	21		28	FRONT/REAR (L-R) DET.
R LOW BAND DET.	22		27	FRONT/REAR (L+R) DET.
L LOW BAND DET.	23		26	AUTOBALANCE LOCKOUT
LOW BAND DET. OUT	24		25	AUTOBALANCE TC

SSM2005

PIN FUNCTION DESCRIPTION

Pin #	Name	Connected to / Function:
1	R Filter In	3-Pole Active Low-Pass Filter Output; used for Center Cancelling Correction
2	R Filter Out	3-Pole Active Low-Pass Filter Input
3	L Filter In	3-Pole Active Low-Pass Filter Output; used for Center Cancelling Correction
4	L Filter Out	3-Pole Active Low-Pass Filter Input
5	L Out	Connect to Pin 6
6	L Out A	Connect to Pin 5
7	L In	Left Stereo Source Line Input; Should be 0 dBd (300 mV rms)
8	R Out	Connect to Pin 9
9	R Out A	Connect to Pin 8
10	R In	Right Stereo Source Line Input; Should be 0 dBd (300 mV rms)
11	V _{EE}	Negative Supply
12	ACOM Audio GND	Audio Ground
13	GND	Power Ground
14	V _{CC}	Positive Supply
15	(L+R) Out	RC to Front/Rear Detector Input
16	(L-R) Out	RC to Front/Rear Detector Input and Input of Crossover
17	(L-R) High In	Output of High-Pass Crossover
18	(L-R) Low In	Output of Low-Pass Crossover
19	R High Band Det.	RC Network Fed by Right Stereo Source Line Input
20	L High Band Det.	RC Network Fed by Left Stereo Source Line Input
21	High Band Det. Out	Capacitor to ACOM; Controls Rear High Frequency Output Steering
22	R Low Band Det.	Right Input, used for Autobalance and Low Band Steering
23	L Low Band Det.	Left Input, used for Autobalance and Low Band Steering
24	Low Band Det. Out	Capacitor to ACOM; Controls Left-to-Right Output Steering
25	Autobalance TC	RC Network to ACOM
26	Autobalance Lockout	RC Network to ACOM
27	Front/Rear (L+R) Det.	RC Network Fed by (L+R) Out (Pin 15)
28	Front/Rear (L-R) Det.	RC Network Fed by (L-R) Out (Pin 16)
29	Front/Rear Det.	Capacitor to ACOM; Controls Front-to-Back Output Steering
30	High Band TC Filter	RC Network to ACOM
31	Low Band TC Filter	RC Network to ACOM
32	Front/Rear TC Filter	RC Network to ACOM
33	Clock In	Clock from Serial Bus
34	<u>WRITE</u>	Chip Select from Serial Bus
35	V _{EE}	Negative Supply
36	GND	Power Ground
37	ACOM Audio GND	Audio Ground
38	V _{CC}	Positive supply
39	Data In	Data from Serial Bus
40	<u>Reset</u>	Reset from Serial Bus
41	<u>LOAD</u>	Load from Serial Bus
42	Noise Out	Connect to RC Filter; White Noise Output
43	Noise In	Connect to RC Filter Output; Filtered White Noise
44	RS Out	Connect to Right Surround (Rear) Amplifier Input
45	LS Out	Connect to Left Surround (Rear) Amplifier Input
46	RF Out	Connect to Right Front Amplifier Input
47	LF Out	Connect to Left Front Amplifier Input
48	Center Out	Connect to Center Amplifier Input

Table I. Abbreviations and Notations Used in the Text

L	Left	LF	Left Front Output	C	Center Output
R	Right	RF	Right Front Output	dBd	0 dBd = 300 mV rms
L _T	Surround Encoded Left Input	LS	Left Surround Output	ACOM	Quality Audio Ground
R _T	Surround Encoded Right Input	RS	Right Surround Output	VCA	Voltage Controlled Amplifier

SIMPLIFIED THEORY OF OPERATION

General

The SSM2005 Circle Surround decoder processes stereo input signals, and outputs 5 channels of surround sound, plus an L+R output for a subwoofer low-pass filter. The SSM2005 provides signal processing, steering control, input autobalance, and a digital interface for mode control. This device uses analog circuits such as amplifiers, rms detectors, VCAs and digital logic to carry out the circle surround algorithm in real time. No artificial reverberation or delay effects are used, preserving the natural sound of the original stereo recording.

The SSM2005 can decode any existing media including CD, VCD, DVD, cassette tapes, VHS, FM radio and television stereo broadcasts. For convenience in balancing the system, an on-chip digital noise generator is available. The net result is outstanding 5.1 channel surround sound from all stereo sources, which reveals the hidden ambiance already contained in existing music and cinematic recordings. The listening experience is greatly enhanced and made more enjoyable when compared to ordinary stereo. In the following description, please refer to Figure 6.

Input Signal Processing

Stereo inputs L and R are fed to both the Steering Control Generator, and the Autobalance circuitry. The balanced signals are passed through the Center Channel Cancel circuitry to the Channel Steering VCAs.

The autobalance output signals also feed the Precision Sum and Difference Amplifiers. The sum (L+R) and difference (L-R) signals form the basis for the center and surround channels, respectively. The center channel signal is fed to the center channel cancel circuitry, and to the channel steering VCAs. The surround channel signal is separated by an external Crossover Network into the Surround High and Surround Low bands and fed to the channel steering VCAs.

Steering Control Generator

The purpose of the steering control generator is to analyze the dynamic characteristics of music, dialog, or special effects, using proprietary high speed analog computing circuits. Control voltages for all VCAs are then computed, and the soundfield expansion performed in accordance with the circle surround decoding algorithm. The control signals depend upon the SSM2005 modes selected, and will differ for video mode vs. music mode, 5.2.5 mode vs. 4.2.4 mode, etc.

Channel Steering VCAs

Command signals from the steering control generator are fed to the channel steering VCAs, which control the amplitude of the five output channels. High performance, low distortion VCAs with typically 12 dBd headroom are used for all channels.

Output Amplifier

The Output Amplifiers receive signals from the VCAs and the internal Noise Generator. Each amplifier has a multiplexer switch which will enable it to output a white noise waveform under control of the Serial Bus. This simplifies balancing of the listening system. The output amplifiers provide load drive capability with typically 12 dBd of headroom. The overall gain from L and R inputs to Circle Surround Outputs is unity; the Noise Generator gives an output level of -10 dBd (100 mV rms).

Mode Control Logic

The various SSM2005 modes are shown in Figure 7. There are modes for different types of source material, such as video sound tracks or music. Other modes include 5.2.5/4.2.4, Sound Spread, Phantom Center mode, autobalance, and Noise Generation. Each mode's status is stored in the Mode Control Logic, as determined by the data sent via the serial bus. Refer to the Typical Outputs In Various Modes section for a more detailed explanation of the various modes.

Applying a logic low to the Reset input will override the Mode Control Logic and put the SSM2005 into its Default mode. Default modes for the device are video/5.2.5/center active/sound spread on/autobalance on/noise off. See Figure 9 for logic timing diagrams.

Autobalance Feature

The autobalance circuitry is activated when the SSM2005 is placed into autobalance On Mode. In this mode, the device will adjust the gains of its input amplifiers to balance the stereo inputs to equal loudness. With a mono input signal, the autobalance circuitry will typically balance L and R to within ± 0.5 dB. A 22 μ F external capacitor connected to Pin 25 sets a 5 second averaging period for comparing the levels between the stereo inputs.

Using autobalance will slightly degrade the maximum channel separation from the SSM2005. The autobalance mode can be left off without fear of degrading the soundfield, unless the stereo input signal is expected to be off balance by more than ± 1.5 dB. Most CD, VCD and DVD player outputs are specified to within ± 0.25 dB balance.

Noise Generator

When the noise mode is selected, the audio inputs are muted. Noise will be available from the output of the channel determined by the mode control logic. The noise generator uses a feedback shift register that generates a pseudo-random digital output waveform with a repeat time of three seconds. This digital noise waveform is band-pass filtered externally to approximate white noise.

Power Supplies

The SSM2005 may be operated from regulated ± 5 V to ± 6 V supplies that can supply 45 mA each. The recommended operating voltage is ± 6 V, which will give a typical headroom of 12 dBd.

SSM2005

Power-Up

The SSM2005 will be in an undefined mode on power-up. Reset should be applied to the SSM2005, or the mode control logic should be loaded to put the device into a definite mode state.

Serial Data Control Inputs

The SSM2005 provides a simple 3- or 4-wire serial interface to control the mode settings for the device. Data is input on the DATA IN pin, while CLOCK IN is the serial clock. Data can be shifted into the SSM2005 at clock rates up to 1 MHz.

The shift register clock at CLOCK IN is enabled when the $\overline{\text{WRITE}}$ input is low. The $\overline{\text{WRITE}}$ pin can therefore be used as a chip select input. However, the shift register contents are not transferred into the register banks until the rising edge of $\overline{\text{LOAD}}$. For a traditional 3-wire serial interface, $\overline{\text{WRITE}}$ and $\overline{\text{LOAD}}$ should be tied together. Figure 7 shows the timing diagram and minimum timing requirements for the digital interface.

To enable a data transfer, the $\overline{\text{WRITE}}$ and $\overline{\text{LOAD}}$ inputs are driven low. The 8-bit serial data, formatted MSB first, should be fed to DATA IN and clocked into the shift register on the rising edge of CLOCK IN. The new mode setting will then activate on the rising edge of $\overline{\text{WRITE}}$ and $\overline{\text{LOAD}}$.

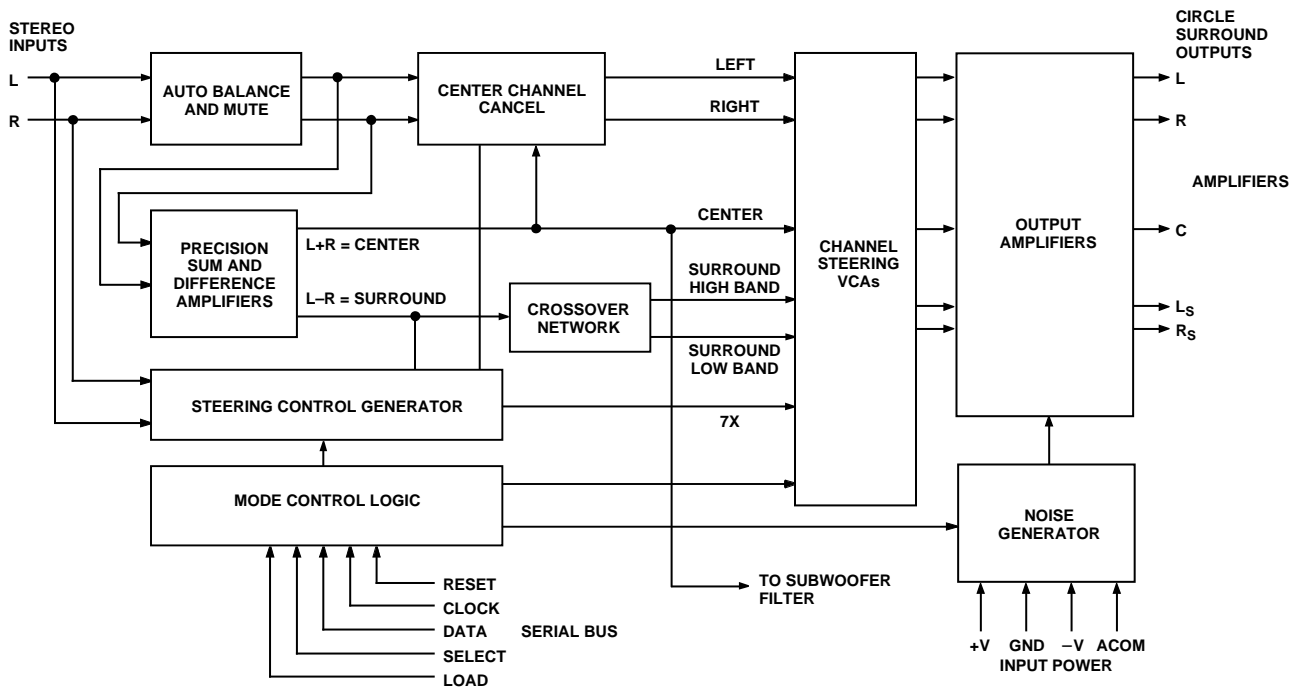

Figure 6. Block Diagram

Table II. Modes List

Modes	Effect
Video Music	Center Channel Cancellation Active Center Cancel Cancellation Off; Center Reduced by -4 dB.
5-2-5 4-2-4	5-Channel Circle Surround Enabled 4-Channel Matrix Enabled
Center On Phantom Center	Center Channel Output On Center Channel Output Off; Divided and Added to LF and RF
Sound Spread On Sound Spread Off	Hard Panned Input Steered to Front and Rear Side Hard Panned Input Steered to Front Side Only
Autobalance On Autobalance Off	Balances L and R to ± 1 dB Autobalance Disabled
Noise Off Noise On	Noise Generator Disabled Noise Generator On; Inputs Muted

Table III. Data Decoding Truth Table

Reset	MSB D0	D1	D2	D3	D4	D5	D6	LSB D7	Mode
1	0	0	1	X	X	X	X	X	C Noise On
1	1	0	1	X	X	X	X	X	LF Noise On
1	1	1	0	X	X	X	X	X	RF Noise On
1	0	1	0	X	X	X	X	X	LS Noise On
1	1	0	0	X	X	X	X	X	RS Noise On
1	0	0	0	X	X	X	X	X	All Mute
1	1	1	1	1	X	X	X	X	Autobalance On
1	1	1	1	0	X	X	X	X	Autobalance Off
1	1	1	1	X	1	X	X	X	Center Active
1	1	1	1	X	0	X	X	X	Phantom Center
1	1	1	1	X	X	1	X	X	Sound Spread On
1	1	1	1	X	X	0	X	X	Sound Spread Off
1	1	1	1	X	X	X	1	X	5.2.5 Mode
1	1	1	1	X	X	X	0	X	4.2.4 Mode
1	1	1	1	X	X	X	X	1	Video Mode
1	1	1	1	X	X	X	X	0	Music Mode
0	X	X	X	X	X	X	X	X	Noise Off, Autobalance On, Center Active, Sound Spread On, 5.2.5 Mode, Video Mode

SSM2005

Table IV. Timing Description

Timing Symbol	Description	Min	Typ	Max	Units
t_{CL}	Input Clock Pulsewidth	50			ns
t_{CH}	Input Clock Pulsewidth	50			ns
t_{DS}	Data Setup Time	25			ns
t_{DH}	Data Hold Time	35			ns
t_{CW}	Positive CLK Edge to End of Write	25			ns
t_{WC}	Write to Clock Setup Time	35			ns
t_{LW}	End of Load Pulse to Next Write (4-Wire Mode)	20			ns
t_{WL}	End of Write to Start of Load (4-Wire Mode)	20			ns
t_L	Load Pulsewidth (4-Wire Mode)	250			ns
t_{W3}	Load Pulsewidth (3-Wire Mode)	250			ns

NOTES:

1. An idle HI (CLK-HI) or idle LO (CLK-LO) clock may be used. Data is latched on the positive edge.
2. For SPI™ or MICROWIRE™ 3-wire bus operation, tie \overline{LD} to \overline{WRITE} and use \overline{WRITE} pulse to drive both pins. (This generates an automatic internal \overline{LD} signal.)
3. If an idle HI clock is used, t_{CW} and t_{WL} are measured from the final negative transition to the idle state.
4. The first data byte selects an address (MSB HI), and subsequent MSB LO states set gain levels. Refer to the Address/Data Decoding Truth Table.
5. Data must be sent MSB first.

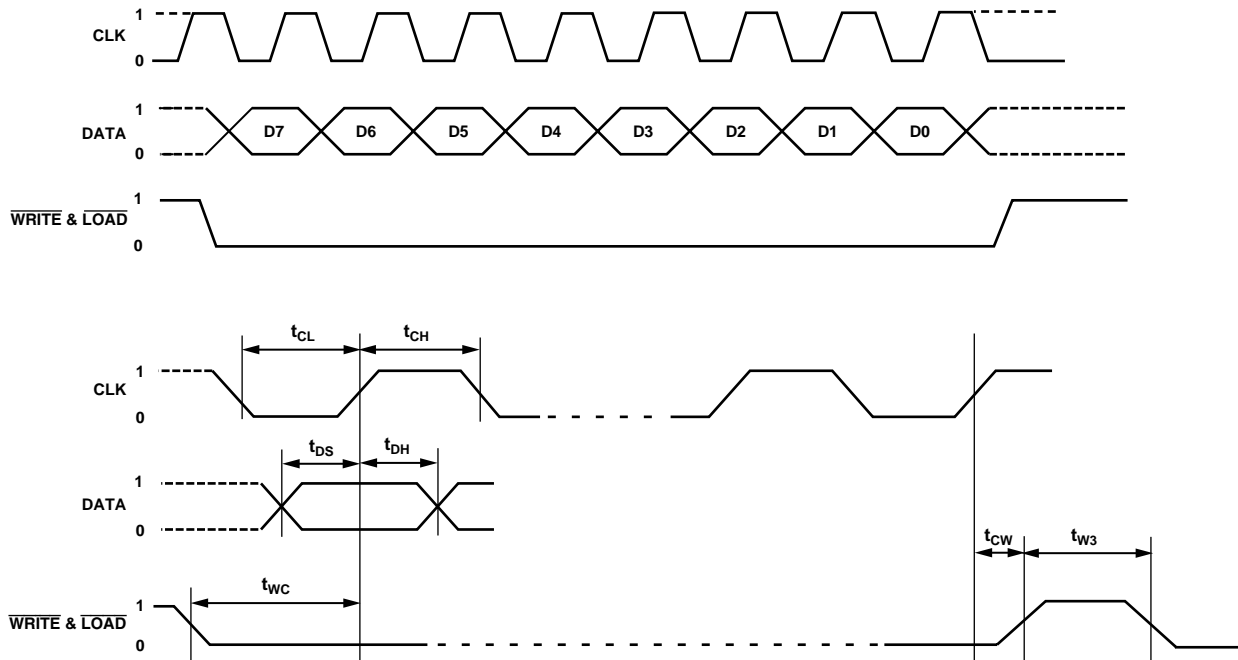

Figure 7. Logic Timing Diagram

TYPICAL OUTPUTS IN VARIOUS MODES

The SSM2005 Circle Surround decoder uses ambiance and directional information already present in a stereo signal, and does not require the audio signal to be encoded. The device requires no delay generators or noise reduction. Fully differentiated rear channels provide rear stereo separation for enhanced spatial perception, a feature unique to Circle Surround.

Video mode provides the highest degree of channel separation between the front and center speakers. Video mode cancels common center channel material from the left and right front channels. This restores a wide stereo image to matrix encoded sound tracks, while maintaining a solid center channel for dialogue and mono information.

The Music mode is optimized for unencoded stereo music reproduction, with full bandwidth on all channels. The steering for the LF and RF channels is deactivated to prevent any stereo image wandering. The independent two-band rear channel steering provides excellent surround imaging, even in car audio applications. Well balanced sound is obtained everywhere within a 4- or 5-speaker setup.

The 5.2.5 mode provides the maximum channel separation to the surround channels, and should be used with any encoded stereo input signal. The 4.2.4 mode can be used to reduce the dynamic steering of the surround channels, allowing the SSM2005 to simulate a 4-channel surround sound decoder.

Sound Spread OFF allows the maximum channel separation between the surround and front speakers. With Sound Spread OFF, a hard panned left input signal will produce an output only in the left front output. In Sound Spread ON mode, a hard panned left input signal will produce equal output from the left front and left surround outputs.

The following tables demonstrate the differences between the modes of the SSM2005 under various input conditions. The L_T and R_T inputs are at 2 kHz, and are shown in terms of their differences in magnitude (in dB) and phase (in degrees). For example, a $0 \angle 180^\circ$ input means L_T is exactly equal in magnitude, but opposite in phase to R_T .

Table V. Video/5.2.5/Sound Spread OFF/Center ON

Input $ L_T - R_T $	Output (dB)				
	LF	RF	C	LS	RS
$0 \angle 0^\circ$	-30	-30	+6	-40	-40
$0 \angle 180^\circ$	-35	-35	-45	+6	+6
L_T Only	0	-60	-30	-30	-35
R_T Only	-60	0	-30	-35	-30
$-6 \angle 0^\circ$	0	-15	-4	-25	-30
$-6 \angle 180^\circ$	-30	-36	-26	0	-15

Table VI. Video/5.2.5/Sound Spread ON/Center ON

Input $ L_T - R_T $	Output (dB)				
	LF	RF	C	LS	RS
$0 \angle 0^\circ$	-30	-30	+6	-40	-40
$0 \angle 180^\circ$	-35	-35	-45	+6	+6
L_T Only	0	-60	-30	0	-30
R_T Only	-60	0	-30	-30	0
$-6 \angle 0^\circ$	0	-15	-4	0	-25
$-6 \angle 180^\circ$	-30	-36	-26	0	-15

Table VII. Music/5.2.5/Sound Spread ON/Center ON

Input $ L_T - R_T $	Output (dB)				
	LF	RF	C	LS	RS
$0 \angle 0^\circ$	0	0	+2	-40	-40
$0 \angle 180^\circ$	0	0	-45	+6	+6
L_T Only	0	-60	-30	0	-30
R_T Only	-60	0	-30	-30	0
$-6 \angle 0^\circ$	0	-6	-4	0	-25
$-6 \angle 180^\circ$	0	-6	-26	0	-15

Table VIII. Video/5.2.5/Sound Spread ON/Phantom Center

Input $ L_T - R_T $	Output (dB)				
	LF	RF	C	LS	RS
$0 \angle 0^\circ$	+3	+3	Off	-40	-40
$0 \angle 180^\circ$	-35	-35	Off	+6	+6
L_T Only	0	-60	Off	0	-30
R_T Only	-60	0	Off	-30	0
$-6 \angle 0^\circ$	0	-15	Off	0	-25
$-6 \angle 180^\circ$	-30	-36	Off	0	-15

Table IX. Video/4.2.4/Sound Spread OFF/Center ON

Input $ L_T - R_T $	Output (dB)				
	LF	RF	C	LS	RS
$0 \angle 0^\circ$	-30	-30	+6	-40	-40
$0 \angle 180^\circ$	-35	-35	-45	+6	+6
L_T Only	0	-60	-30	-32	-32
R_T Only	-60	0	-30	-32	-32
$-6 \angle 0^\circ$	0	-15	-4	-26	-26
$-6 \angle 180^\circ$	-30	-36	-26	0	-2

SSM2005

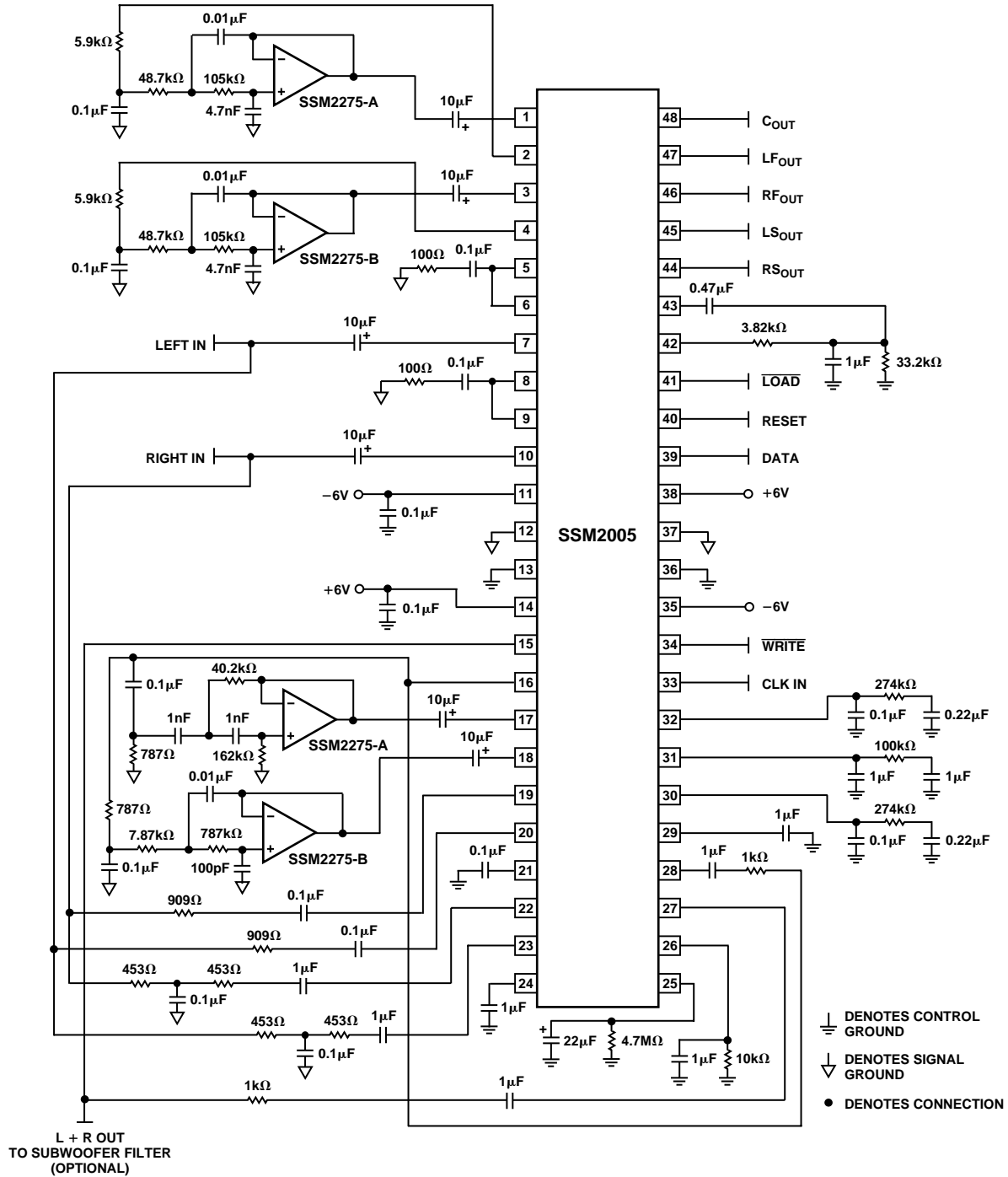

Figure 8. Typical Application Schematic

APPLICATION NOTES

Figure 8 shows a typical SSM2005 application schematic. The stereo source signal is connected to the SSM2005 audio signal inputs at Pins 7 and 10, as well as the Left/Right level detectors at Pins 19, 20, 22, and 23. The input signal goes through the autobalance circuitry and can be accessed at Pins 6 and 9. A sum (L+R) and difference (L-R) signal is available at Pins 15 and 16, respectively. These signals are fed into the Front/Rear level detector at Pins 27 and 28.

The L+R signal is also fed internally to the center channel VCA to produce the center channel output at Pin 48. In addition, the L-R signal is fed into two external filters, creating a low-band and high-band signal with a crossover frequency of 2 kHz. The crossover filters are both 3rd order Bessel filters, providing a minimum group delay to the surround channels. The L-R high-band signal is connected to Pin 17, and the L-R low-band signal is connected to Pin 18. These two pins provide the multiband steering to the two surround outputs.

Low-pass filters are inserted between Pins 1 and 2, and Pins 3 and 4. These filters are used for the center-canceling circuitry, which removes center channel information from the left front and right front outputs. This circuitry is only active in Video mode, providing maximum channel separation between the center and front outputs. In an application that will only use Music mode, these active filters can be removed and replaced with a 1 μ F capacitor between Pins 1 and 2, and Pins 3 and 4.

The capacitors and resistors connected to Pins 21, 24, 25, 26, 29, 30, 31 and 32 are used to create the time constants for the steering circuitry. The values shown in Figure 8 are strongly recommended. Variation from these values will result in improper operation of the Circle Surround decoder, and may result in the assembled unit failing SRS Labs approval.

The noise generator output is at Pin 42, and the input to the noise steering circuit is at Pin 43. The R-C network connected between Pins 42 and 43 is used to remove dc voltage and high frequencies, which could damage speakers. Other noise-shaping circuitry could be used here to create noise patterns other than white, or to further attenuate the noise output with a resistor divider.

Adding a Subwoofer Output

The SSM2005 provides an output of the summed Left In and Right In signals. This L+R signal is used to drive the center channel output, and it can also be used to provide a subwoofer channel by connecting the output from Pin 15 to a low-pass filter. The schematic for such a configuration is shown in Figure 9.

Here, Pin 15 is connected to a 2nd order Bessel low-pass filter. The circuit uses the SSM2275, a low noise audio op amp that can run from the same ± 6 V that power the SSM2005. Using the component values shown in Figure 9, the filter's cutoff frequency is 100 Hz.

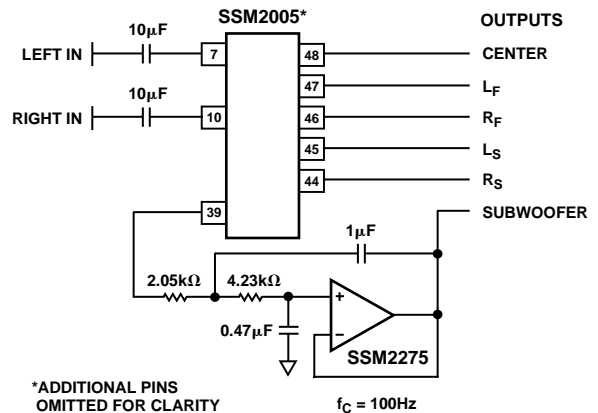

Figure 9. Adding a Subwoofer Output

Implementing a Stereo Bypass Mode

Figure 10 shows a schematic for implementing a clickless stereo bypass around the SSM2005. The stereo bypass mode allows the user to defeat the Circle Surround decoding and listen to two-channel stereo from the left front and right front speakers.

The SSM2402 is a clickless dual audio single-pole single-throw (SPST) switch. When the control voltage, V_{BYP} , is low (below +0.8 V) the switch is open, and the five channel outputs are connected to the outputs of the SSM2005. When V_{BYP} goes high (above +2.0 V) the SSM2402 switch closes, connecting the LF and RF outputs to Left In and Right In respectively. At the same time, a data byte should be loaded into the SSM2005, placing the Circle Surround decoder into Mute Mode. The data byte required for Mute Mode can be found in Table III, and the logic timing diagrams can be found in Figure 7.

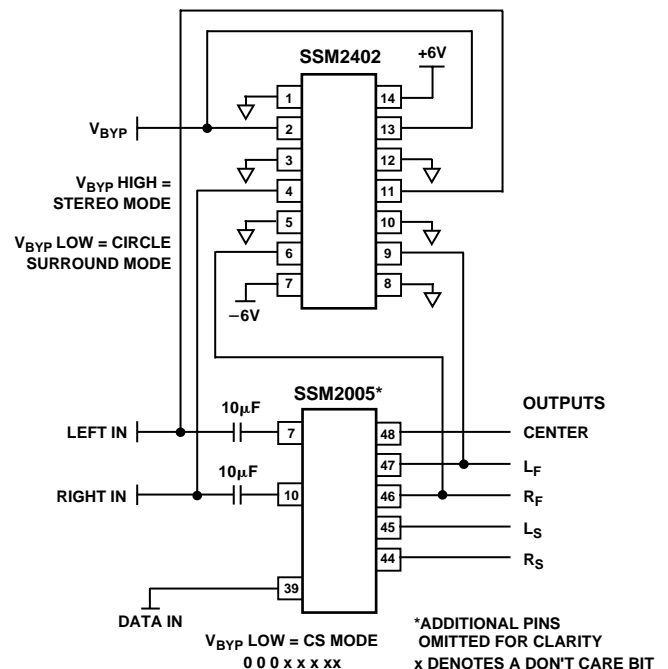

Figure 10. Implementing a Clickless Stereo Bypass Mode

SSM2005

Using the SSM2005 for Karaoke

In Video mode, the SSM2005 removes centered vocal information from the LF and RF speakers. This allows the device to be used in Karaoke applications, where the user can sing along with any music recording. Figure 11 shows a circuit diagram for such an application.

The OP179 is the microphone preamplifier with a gain of +20 dB. A 2.2 kΩ resistor connects the microphone to the +6 V supply rail, providing proper biasing for an electret microphone.

The SSM2402 is used as a clickless switch, connecting the center output to either the center out from the SSM2005 or the microphone. In Circle Surround mode, the control voltages to the SSM2402 connect the output from the SSM2005 to the center output.

In Karaoke Mode, this connection is opened, and the microphone is directed to the center output. At the same time, the SSM2005 should be loaded with data byte (MSB first):

1 1 1 0 1 0 1 1. This activates the center canceling circuitry in the SSM2005, removing centered vocal information from the left front and right front speakers.

The overall result is the microphone output comes out of the center speaker, with the vocals-removed music coming from the remaining speakers.

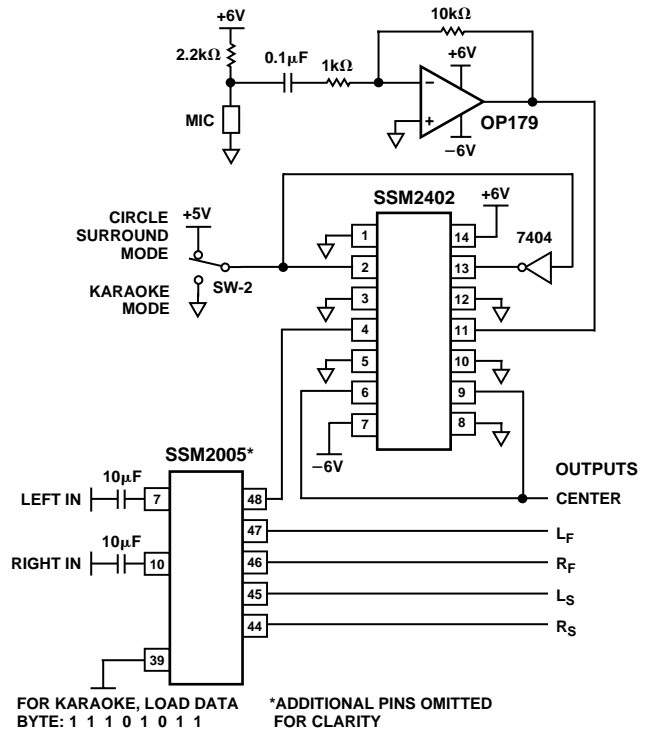

Figure 11. Using the SSM2005 for Karaoke

OUTLINE DIMENSIONS

Dimensions shown in inches and (mm).

**48-Lead SSOP
(RS Suffix)**

