



查询SSM2020供应商

**Solid State
Micro Technology**
for Music

捷多邦, 专业PCB打样工厂, 24小时加急出货

**SSM
2020**

DUAL LINEAR-ANTILOG VOLTAGE CONTROLLED AMPLIFIER

DESCRIPTION

The SSM 2020 is a dual two quadrant multiplier designed to be used with op amps in a wide variety of precision audi-frequency applications including AGC circuits, Dividers and as a Biquad tuning element. Each channel has separate control and differential signal inputs and a current output. The device offers an exceptionally flexible control circuit for each channel which allows simultaneous linear and exponential voltage control of gain or either polarity of current control. Both channels are fully temperature compensated and have 86 dB signal-to-noise ratios at less than 0.1% distortion

FEATURES

- Max Supplies $\pm 18V$
- Dual Design (Independent Control Selection)
- 2% Channel Gain Matching
- 100 dB Control Range
- Simultaneous Linear and Exponential Gain Control
- Differential Signal Inputs
- Current Output
- 86db Signal-to-Noise
- 0.1% Distortion
- Fully Temperature Compensated

APPLICATIONS

- 2 and 4 Quadrant Multipliers
- Dividers
- AGC Circuits
- Voltage Controlled Filters
- Voltage Controlled Quadrature Oscillators
- Volume Controls
- Equalizers
- Companders
- Antilog Amplifiers
- Voltage Controlled Current Sources



Pin Diagram

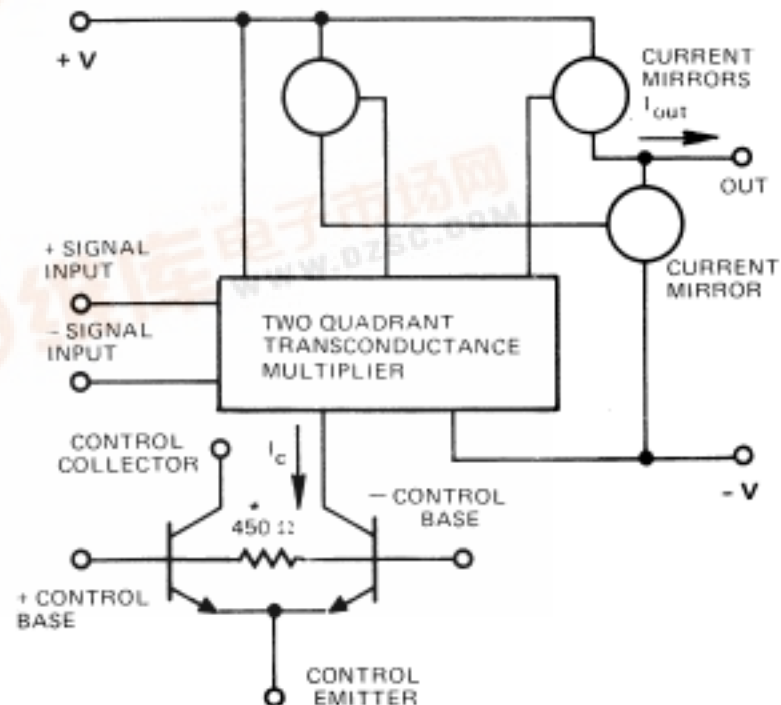

Equivalent Schematic (One Side)



SPECIFICATIONS

$V_S = \pm 15V$, $I_{c1} = I_{c2} = 500 \mu A$ and $T_A = 25^\circ C$, unless otherwise specified.

PARAMETERS	MIN	TYP	MAX	CONDITIONS
Signal Input Bias I_b Supply Voltage V_S Supply Current I_S Control Current	± 6	500 nA ± 15 6 mA	2.2 μA ± 18 8 mA 1 mA	$V_{ee} + 3V \leq V_+, V_- \leq V_{cc} - 3V$ $I_{c1} = I_{c2} = 1 \text{ mA}$
Transconductance g_m gm match gm Tempco	1/12k Ω	1/14 k Ω +2% 100 ppm/ $^\circ C$	1/16 k Ω $\pm 5\%$	$I_{c1} = I_{c2} = 1 \text{ mA}$
Control Circuit V_{os}		1 mV	3 mV	
Output Offset I_o/I_c Control Rejection		$\pm 2\%$ 60 dB	$\pm 10\%$	$V_+ = V_- = \text{GND}$ (untrimmed) $0 \leq I_c \leq 1 \text{ mA}$ (trimmed)
450 Ω Resistor 450 Ω Temp Coef	350 Ω	450 Ω +2000 ppm/ $^\circ C$	550 Ω	
Channel Separation		100 dB		$F = 1 \text{ kHz}$
Bandwidth (3 dB)		1 MHz 300 kHz 30 kHz		$I_c = 1 \text{ mA}^*$ $I_c = 10 \mu A$ $I_c = 100 \text{ nA}$
<i>Feedthrough:</i> -Input to Output + Input to Output		90 dB 100 dB		$F = 1 \text{ kHz}, I_c = 0$ $F = 1 \text{ kHz}, I_c = 0$
Signal/Noise		86 dB		$V_s = 6 \text{ V}_{pp}, I_c = 1 \text{ mA}$
Distortion (THD) VCA (Open Loop) VCF (Closed Loop) As below		0.1% 0.02%		$V_s = 6 \text{ V}_{pp}, I_c = 1 \text{ mA}$ $V_s = 6 \text{ V}_{pp}, I_c = 1 \text{ mA}$

*Output at Virtual GND

OPERATING TEMPERATURE

-25 $^\circ C$ to +75 $^\circ C$ – Commercial

-55 $^\circ C$ to +125 $^\circ C$ – Military

STORAGE TEMPERATURE

-55 $^\circ C$ to 125 $^\circ C$

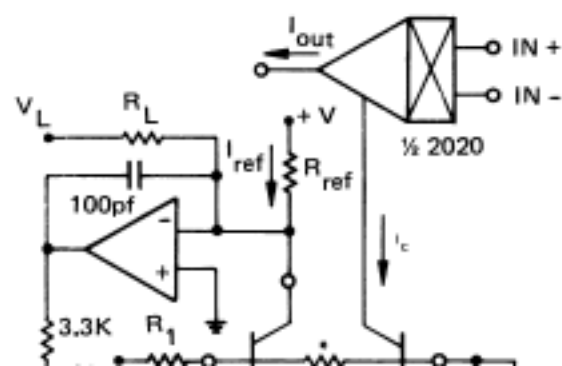

Basic Control Circuit

$$1) I_{out} = g_m (V_+ - V_-)$$

$$2) I_{out} = \frac{I_c (V_+ - V_-)}{14 \text{ volts}}$$

$$3) I_c = e^{-V_b q / KT} (+V/R_{ref} + V_L/R_L)$$

where $V_b = \frac{V_c 450 \Omega}{R_1 + 450 \Omega}$

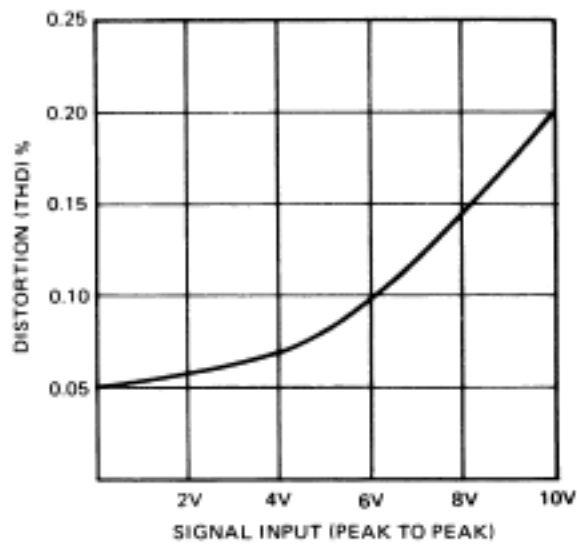

Distortion vs Signal Input

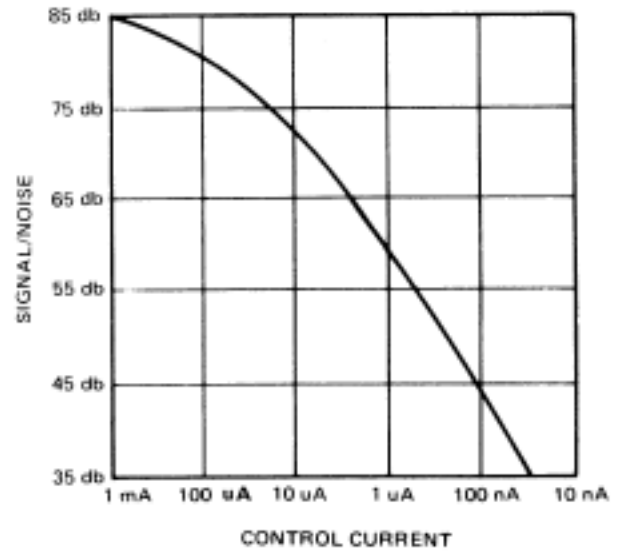

Signal Noise vs Control Current (6 Vpp in)

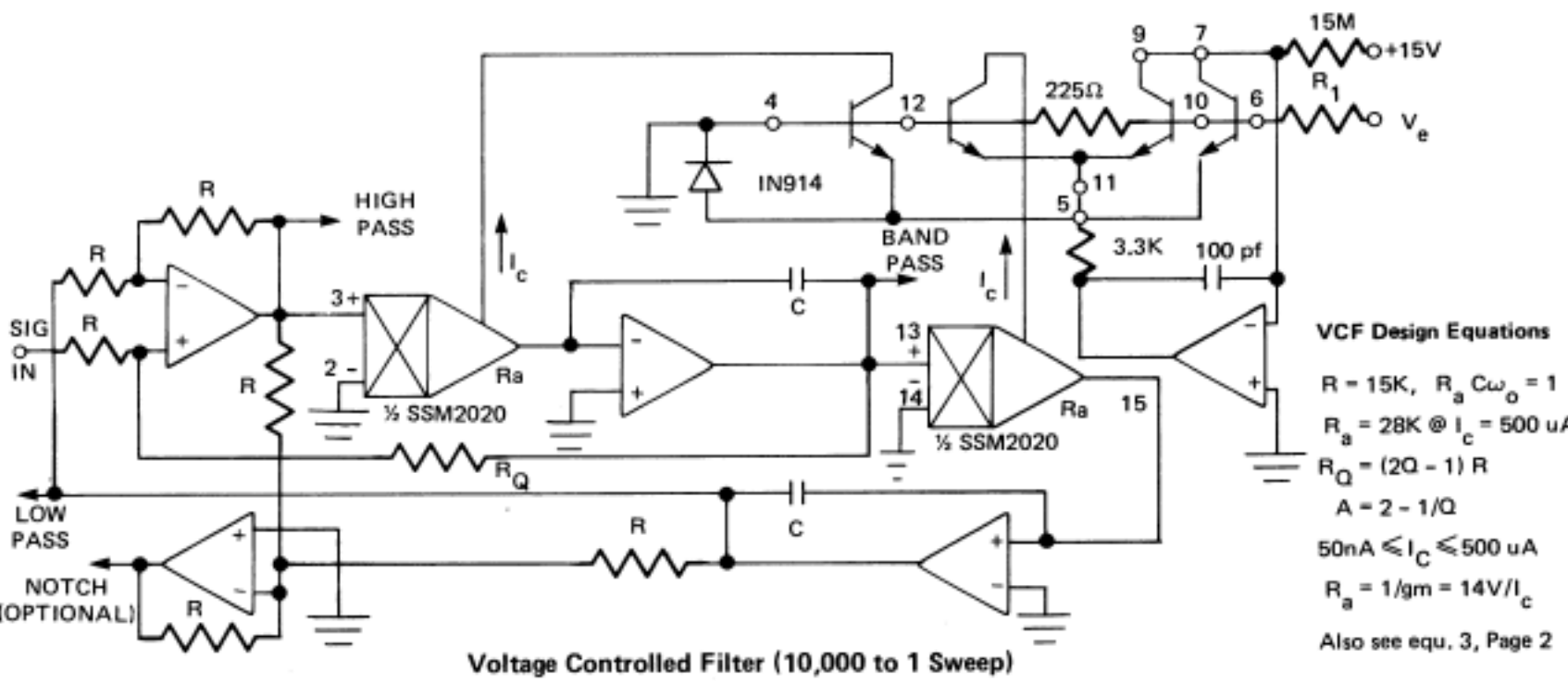

Voltage Controlled Filter (10,000 to 1 Sweep)

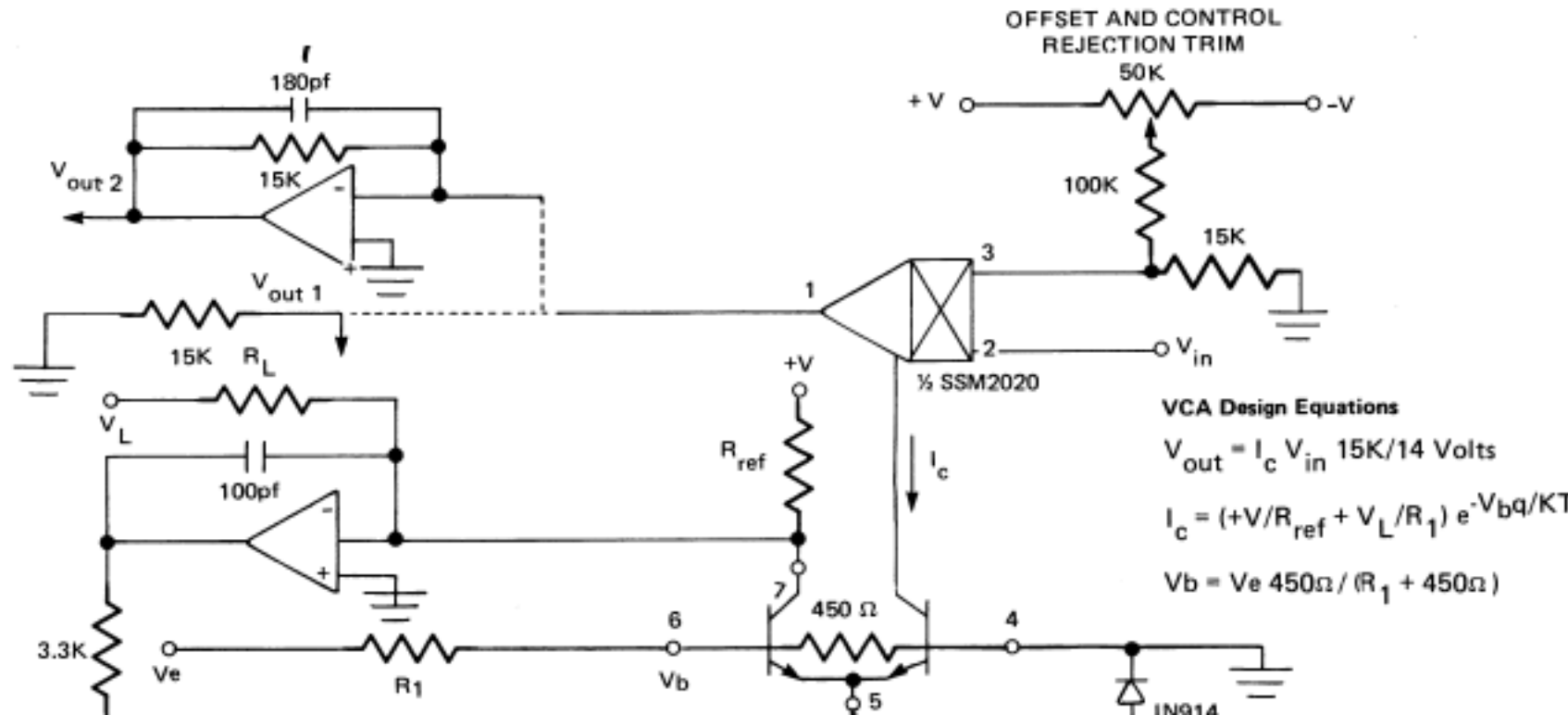

OFFSET AND CONTROL REJECTION TRIM

VCA Design Equations

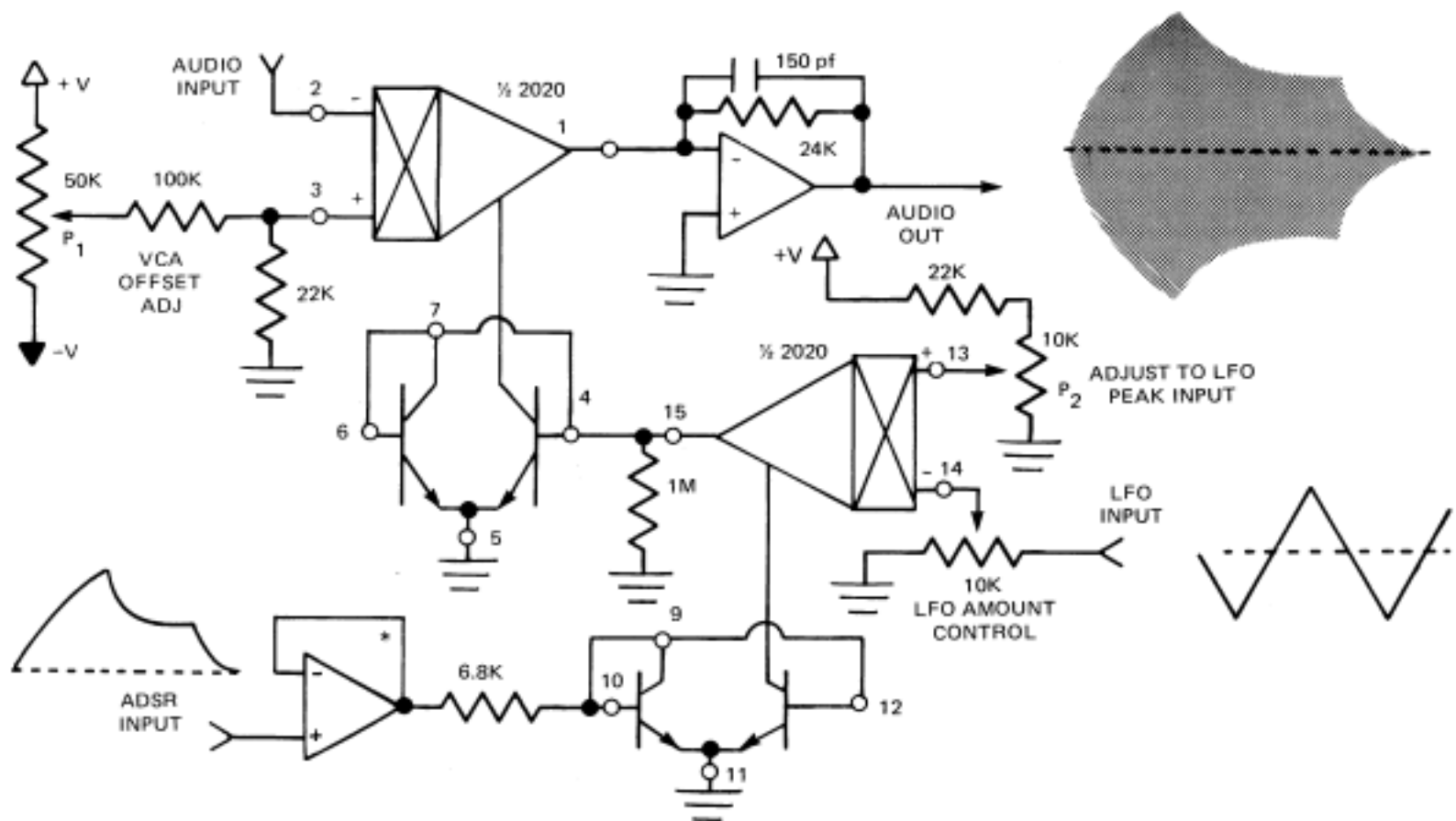

A single 2020 can be connected to add tremello to the output envelope of a VCA. Tremello depth can be controlled from 0 to 100%. The adjustment procedure is to apply an audio input to the VCA, turn the LFO amount control all the way on and gate and hold on the ADSR. Trimpot P₂ is then adjusted to give 100% modulation at the VCA output. The VCA offset trimpot P₁ is then adjusted to center the VCA output about ground.

VCA Control Envelopes

0% LFO MODULATION

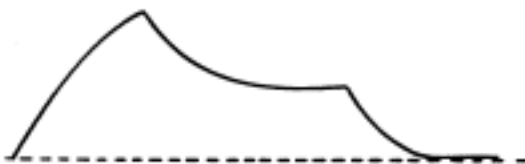

30% LFO MODULATION

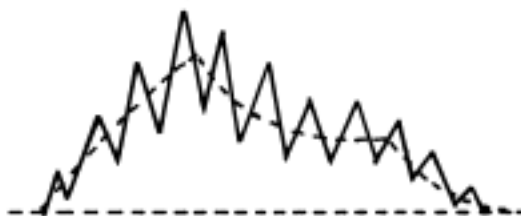

100% LFO MODULATION

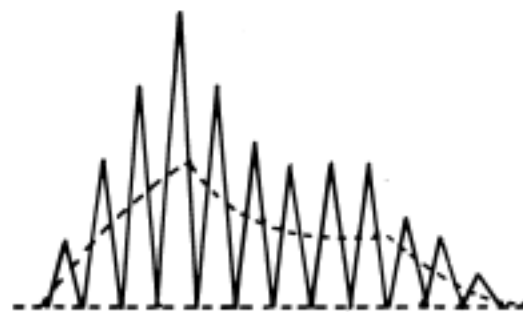

*Buffer required if driving 6.8K load from output of SSM 2050. Not needed for SSM 2055.

