



High Common-Mode Rejection Differential Line Receiver

SSM2141

FEATURES

High Common-Mode Rejection

DC: 100 dB typ

60 Hz: 100 dB typ

20 kHz: 70 dB typ

40 kHz: 62 dB typ

Low Distortion: 0.001% typ

Fast Slew Rate: 9.5 V/ μ s typ

Wide Bandwidth: 3 MHz typ

Low Cost

Complements SSM2142 Differential Line Driver

APPLICATIONS

Line Receivers

Summing Amplifiers

Buffer Amplifiers—Drives 600 Ω Load

FUNCTIONAL BLOCK DIAGRAM

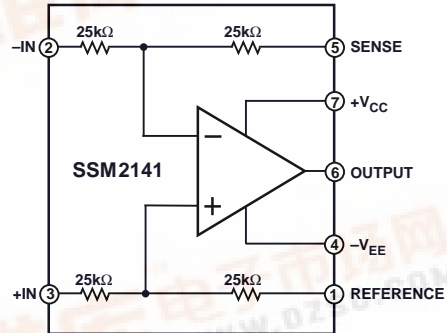

PIN CONNECTIONS

8-Pin Plastic Mini-DIP

(P Suffix)

Narrow Body SO

(S Suffix)

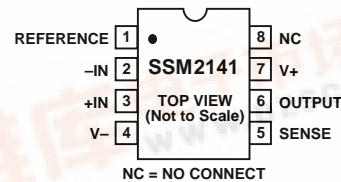

GENERAL DESCRIPTION

The SSM2141 is an integrated differential amplifier intended to receive balanced line inputs in audio applications requiring a high level of noise immunity and optimum common-mode rejection. The SSM2141 typically achieves 100 dB of common-mode rejection (CMR), whereas implementing an op amp with four off-the-shelf precision resistors will typically achieve only 40 dB of CMR—inadequate for high-performance audio.

The SSM2141 achieves low distortion performance by maintaining a large slew rate of 9.5 V/ μ s and high open-loop gain. Distortion is less than 0.002% over the full audio bandwidth. The SSM2141 complements the SSM2142 balanced line driver. Together, these devices comprise a fully integrated solution for equivalent transformer balancing of audio signals without the problems of distortion, EMI fields, and high cost.

Additional applications for the SSM2141 include summing signals, differential preamplifiers, and 600 Ω low distortion buffer amplifiers. For similar performance with $G = 1/2$, see SSM2143.

REV. B

Information furnished by Analog Devices is believed to be accurate and reliable. However, no responsibility is assumed by Analog Devices for its use, nor for any infringements of patents or other rights of third parties which may result from its use. No license is granted by implication or otherwise under any patent or patent rights of Analog Devices.

SSM2141–SPECIFICATIONS

ELECTRICAL CHARACTERISTICS (@ $V_S = \pm 18\text{ V}$, $T_A = +25^\circ\text{C}$, unless otherwise noted)

| Parameter | Symbol | Conditions | SSM2141 | | | Units |
|----------------------------------|----------|---|----------|---------------|------|------------------|
| | | | Min | Typ | Max | |
| OFFSET VOLTAGE | V_{OS} | $V_{CM} = 0\text{ V}$ | -1000 | 25 | 1000 | μV |
| GAIN ERROR | | No Load, $V_{IN} = \pm 10\text{ V}$, $R_S = 0\ \Omega$ | | 0.001 | 0.01 | % |
| INPUT VOLTAGE RANGE | IVR | (Note 1) | ± 10 | | | V |
| COMMON-MODE REJECTION | CMR | $V_{CM} = \pm 10\text{ V}$ | 80 | 100 | | dB |
| POWER SUPPLY REJECTION RATIO | PSRR | $V_S = \pm 6\text{ V}$ to $\pm 18\text{ V}$ | | 0.7 | 15 | $\mu\text{V/V}$ |
| OUTPUT SWING | V_O | $R_L = 2\text{ k}\Omega$ | ± 13 | ± 14.7 | | V |
| SHORT-CIRCUIT CURRENT LIMIT | I_{SC} | Output Shorted to Ground | +45/-15 | | | mA |
| SMALL-SIGNAL BANDWIDTH (-3 dB) | BW | $R_L = 2\text{ k}\Omega$ | | 3 | | MHz |
| SLEW RATE | SR | $R_L = 2\text{ k}\Omega$ | 6 | 9.5 | | V/ μs |
| TOTAL HARMONIC DISTORTION | THD | $R_L = 100\text{ k}\Omega$ $R_L = 600\ \Omega$ | | 0.001 0.01 | | % |
| CAPACITIVE LOAD DRIVE CAPABILITY | C_L | No Oscillation | | 300 | | pF |
| SUPPLY CURRENT | I_{SY} | No Load | | 2.5 | 3.5 | mA |

NOTES

¹Input Voltage Range Guaranteed by CMR test.

Specifications subject to change without notice

ELECTRICAL CHARACTERISTICS (@ $V_S = \pm 18\text{ V}$, $-40^\circ\text{C} \leq T_A \leq +85^\circ\text{C}$)

| Parameter | Symbol | Conditions | Min | Typ | Max | Units |
|------------------------------|----------|---|----------|------------|------|------------------|
| | | | | | | |
| GAIN ERROR | | No Load, $V_{IN} = \pm 10\text{ V}$, $R_S = 0\ \Omega$ | | 0.002 | 0.02 | % |
| INPUT VOLTAGE RANGE | IVR | (Note 1) | ± 10 | | | V |
| COMMON-MODE REJECTION | CMR | $V_{CM} = \pm 10\text{ V}$ | 75 | 90 | | dB |
| POWER SUPPLY REJECTION RATIO | PSRR | $V_S = \pm 6\text{ V}$ to $\pm 18\text{ V}$ | | 1.0 | 20 | $\mu\text{V/V}$ |
| OUTPUT SWING | V_O | $R_L = 2\text{ k}\Omega$ | ± 13 | ± 14.7 | | V |
| SLEW RATE | SR | $R_L = 2\text{ k}\Omega$ | | 9.5 | | V/ μs |
| SUPPLY CURRENT | I_{SY} | No Load | | 2.6 | 4.0 | mA |

NOTES

¹Input Voltage Range Guaranteed by CMR test.

Specifications subject to change without notice

SSM2141

ABSOLUTE MAXIMUM RATINGS¹

| | |
|--|-----------------|
| Supply Voltage | ±18 V |
| Input Voltage ¹ | Supply Voltage |
| Output Short-Circuit Duration | Continuous |
| Storage Temperature Range | |
| P Package | -65°C to +150°C |
| Lead Temperature (Soldering, 60 sec) | +300°C |
| Junction Temperature | +150°C |
| Operating Temperature Range | -40°C to +85°C |

| Package Type | θ_{JA} ² | θ_{JC} | Units |
|-----------------------|----------------------------|---------------|-------|
| 8-Pin Plastic DIP (P) | 103 | 43 | °C/W |

NOTES

¹For supply voltages less than ±18 V, the absolute maximum input voltage is equal to the supply voltage.

² θ_{JA} is specified for worst case mounting conditions, i.e., θ_{JA} is specified for device in socket for P-DIP package.

ORDERING GUIDE

| Model | Operating Temperature Range | Package Description | Package Option |
|----------|---------------------------------------|----------------------|----------------|
| SSM2141P | XIND (-40°C ≤ T _A ≤ +85°C) | 8-Pin Plastic DIP | N-8 |
| SSM2141S | XIND (-40°C ≤ T _A ≤ +85°C) | 8-Pin Narrow Body SO | SO-8 |

Typical Performance Characteristics

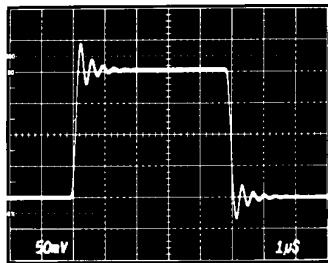

T_A = +25°C
V_S = ±15V

Small Signal Transient Response

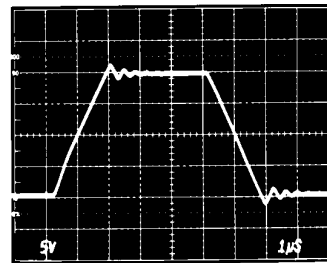

T_A = +25°C
V_S = ±15V

Large Signal Transient Response

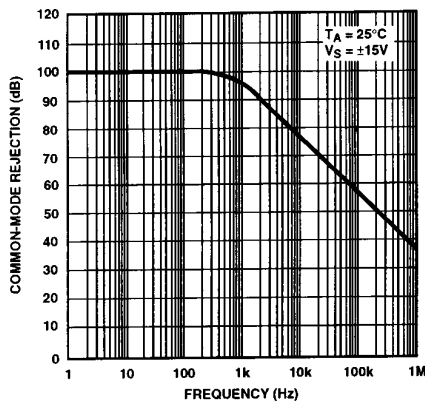

Common-Mode Rejection vs. Frequency

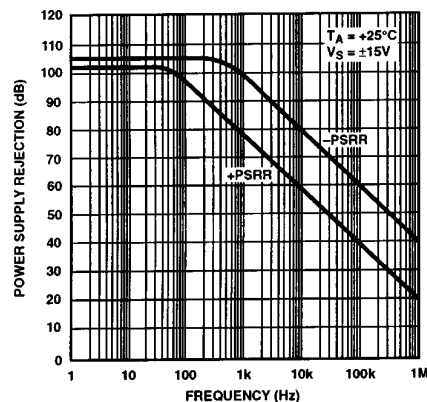

Power Supply Rejection vs. Frequency

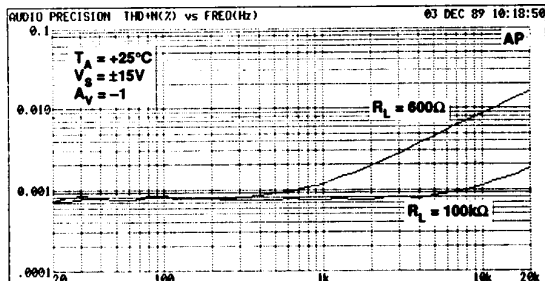

Total Harmonic Distortion vs. Frequency

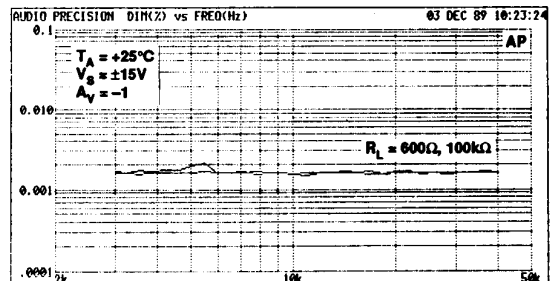

Dynamic Intermodulation Distortion vs. Frequency

SSM2141—Typical Performance Characteristics

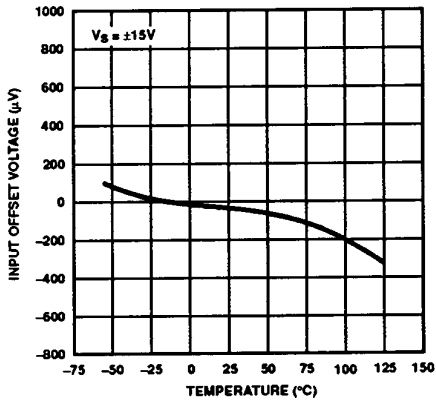

Input Offset Voltage vs. Temperature

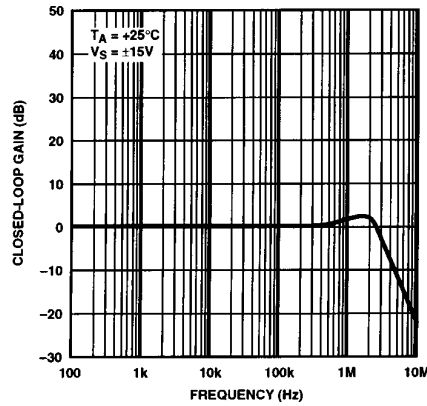

Closed-Loop Gain vs. Frequency

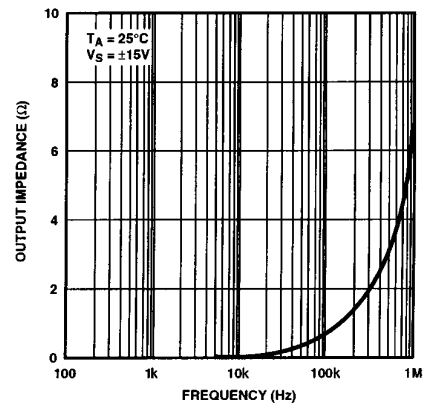

Closed-Loop Output Impedance vs. Frequency

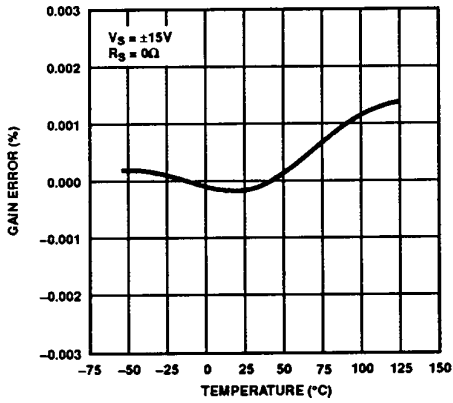

Gain Error vs. Temperature

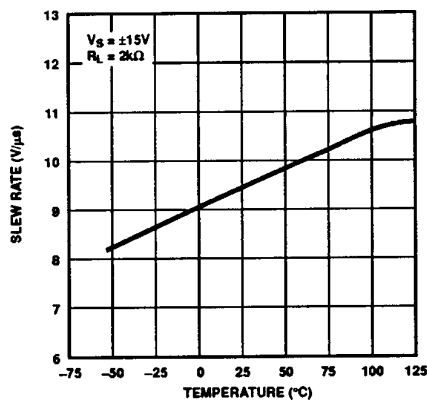

Slew Rate vs. Temperature

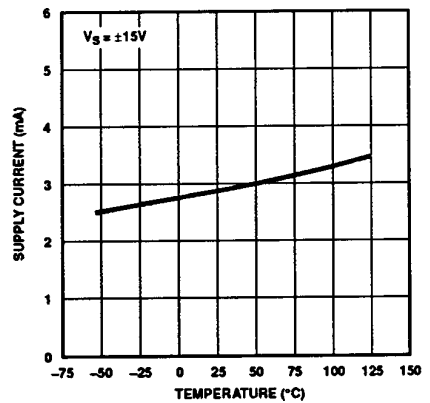

Supply Current vs. Temperature

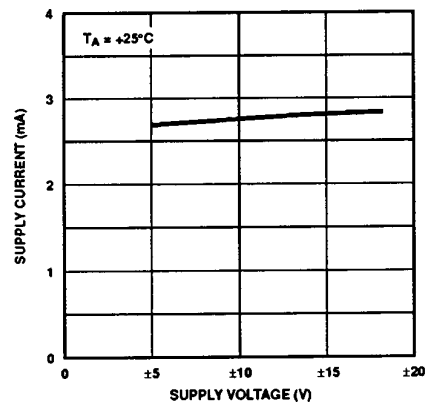

Supply Current vs. Supply Voltage

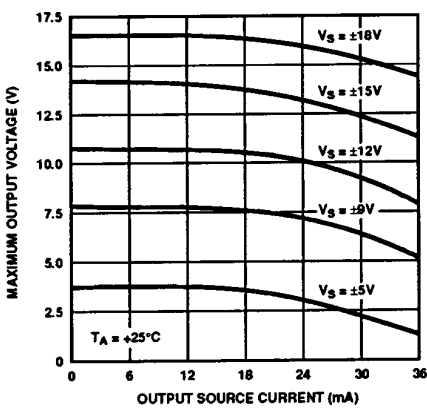

Maximum Output Voltage vs. Output Current (Source)

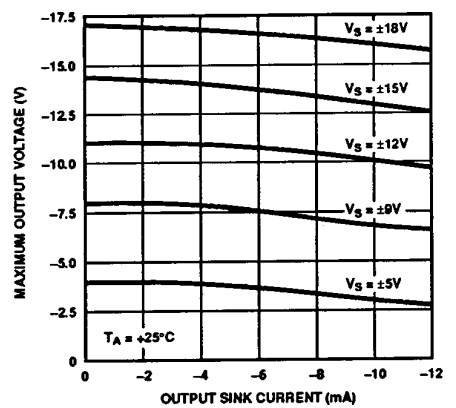

Maximum Output Voltage vs. Output Current (Sink)

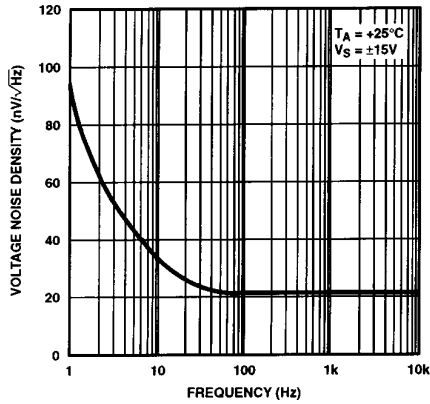

Voltage Noise Density vs. Frequency

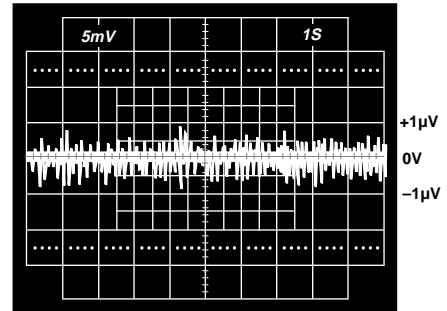

0.1 TO 10Hz PEAK-TO-PEAK NOISE

Low Frequency Voltage Noise

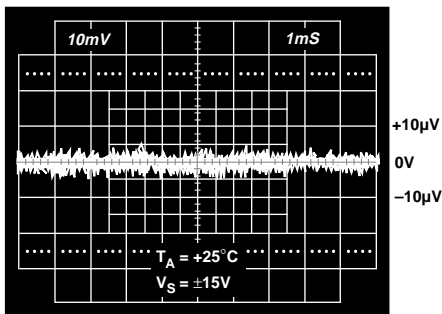

NOTE: EXTERNAL AMPLIFIER GAIN = 1000;
THEREFORE, VERTICAL SCALE = 10µV/DIV.

Voltage Noise from 0 kHz to 1 kHz

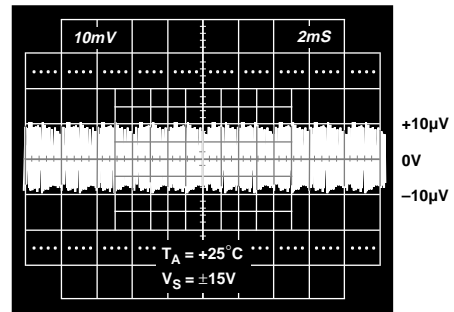

NOTE: EXTERNAL AMPLIFIER GAIN = 1000;
THEREFORE, VERTICAL SCALE = 10µV/DIV.

Voltage Noise from 0 kHz to 10 kHz

APPLICATIONS INFORMATION

The SSM2141 represents a versatile analog building block. In order to capitalize on fast settling time, high slew rate, and high CMR, proper decoupling and grounding techniques must be employed. For decoupling, place 0.1 µF capacitor located within close proximity from each supply pin to ground.

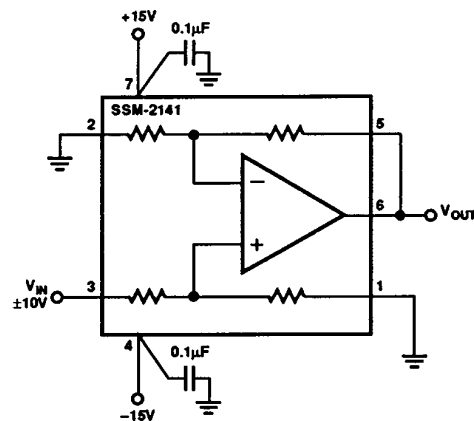

Slew Rate Test Circuit

SSM2141

MAINTAINING COMMON-MODE REJECTION

In order to achieve the full common-mode rejection capability of the SSM2141, the source impedance must be carefully controlled. Slight imbalances of the source resistance will result in a degradation of DC CMR—even a 5 Ω imbalance will degrade CMR by 20 dB. Also, the matching of the reactive source impedance must be matched in order to preserve the CMRR over frequency.

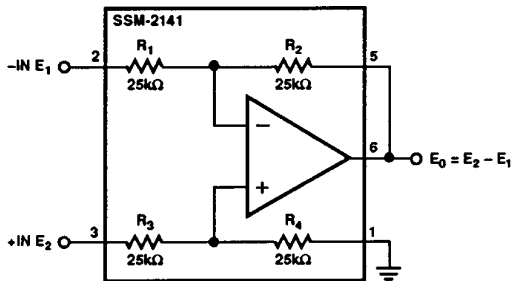

Figure 1. Precision Difference Amplifier. Rejects Common-Mode Signal = $\frac{[E_1 + E_2]}{2}$ by 100 dB

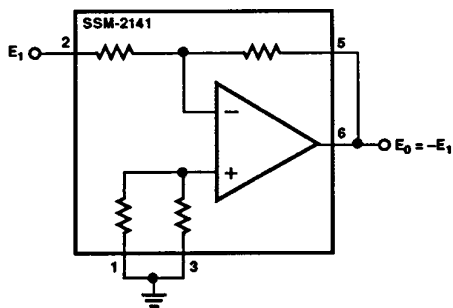

Figure 2. Precision Unity Gain Inverting Amplifier

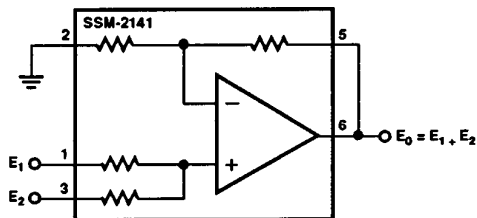

Figure 3. Precision Summing Amplifier

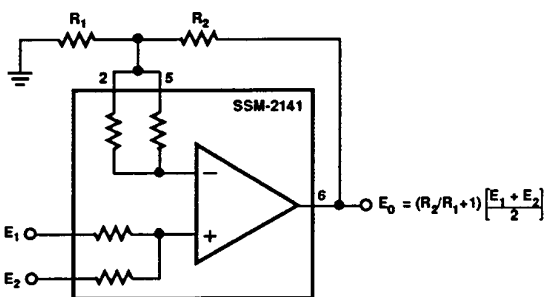

Figure 4. Precision Summing Amplifier with Gain

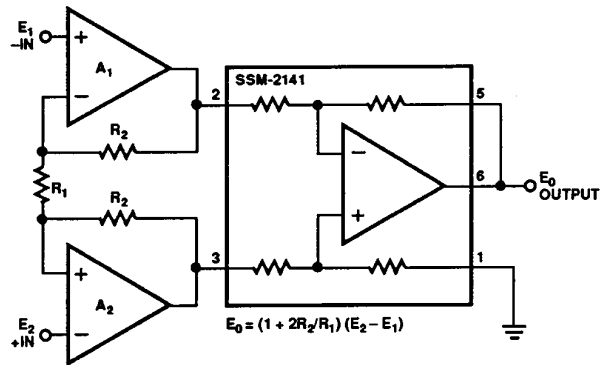
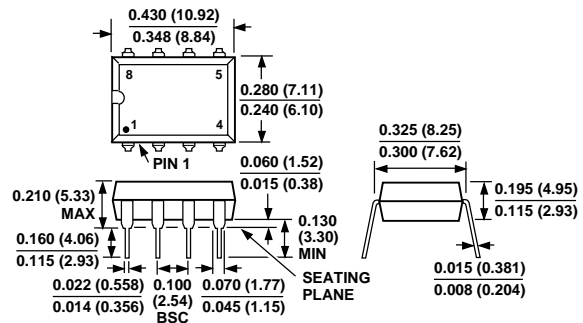

Figure 5. Suitable Instrumentation Amplifier Requirements can be Addressed by Using an Input Stage Consisting of A₁, A₂, R₁ and R₂

OUTLINE DIMENSIONS

Dimensions shown in inches and (mm).

8-Pin Epoxy Mini-DIP P-Suffix (N-8)



8-Pin Narrow Body SO S-Suffix (SO-8)

