



# Digitally Controlled 8 × 2 Audio Mixer

## SSM2163

### FEATURES

- Each of 8 Inputs Can Be Assigned to Either or Both Outputs
- Voltage Inputs and Outputs – No Need For External Amplifiers
- Each Input Provides 63 dB of Attenuation in 1 dB Steps, Plus Mute
- 82 dBu Signal-to-Noise Ratio (0 dBu = 0.775 V rms) +10 dBu of Headroom
- 0.007% THD+N (Unity Gain, @ 1 kHz, 0 dBu)
- Power-Up/System Mute Feature
- Industry-Standard 3-Wire Serial Interface
- Data Out Terminal Permits Daisy Chaining of Multiple SSM2163s
- Single or Dual Supply Operation
- 28-Pin Plastic DIP and SOIC Package

### APPLICATIONS

- Multimedia System Mixing
- Audio Mixing Consoles
- Broadcast Equipment
- Intercom/Paging Systems
- Musical Instruments

### GENERAL DESCRIPTION

The SSM2163 provides eight audio inputs, each of which can be mixed under digital control to a stereo output. Each input channel can be attenuated up to 63 dB in 1 dB intervals, plus fully muted. Additionally, any input can be assigned to either or both outputs. A standard 3-wire serial interface is employed, plus a Data Out terminal to facilitate daisy chaining of multiple mixer ICs. No external components are required for normal operation.

Excellent audio performance is attained. The SSM2163 has a signal-to-noise ratio of -82 dBu (0 dBu = 0.775 V rms), with 10 dBu of headroom resulting in total dynamic range of 92 dBu. Total harmonic distortion plus noise is 0.007% at 1 kHz with all levels set at unity gain.

### SIMPLIFIED BLOCK DIAGRAM

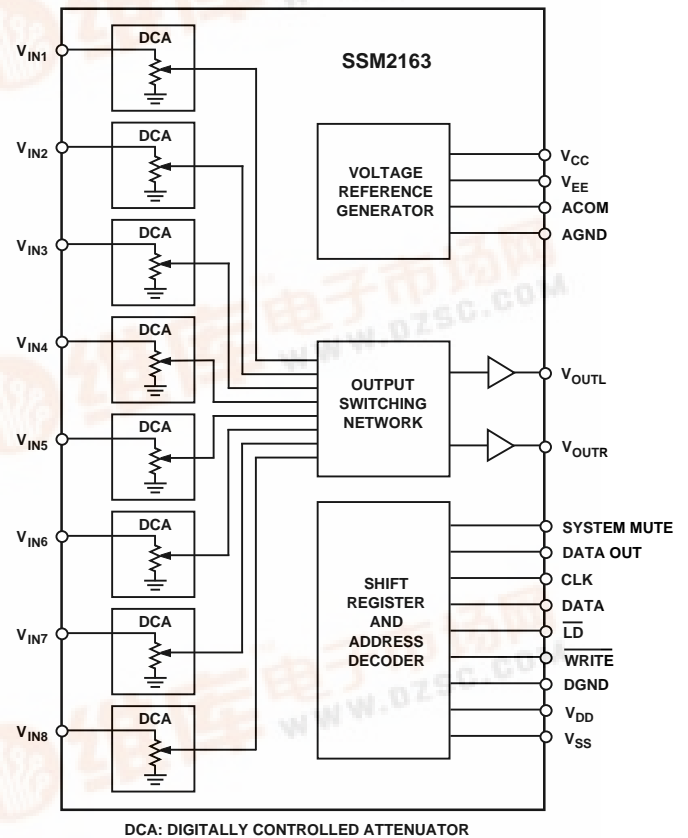

The SSM2163 can be operated from single (+5 V to +14 V) or dual ( $\pm 4$  V to  $\pm 7$  V) supplies, and is housed in 28-pin plastic DIP and SOIC packages.

The SSM2163 is an ideal companion product to the Analog Devices family of stereo codecs in high performance multimedia systems requiring mixing of multiple signals.

# SSM2163–SPECIFICATIONS

## ELECTRICAL SPECIFICATIONS

( $V_S = \pm 5\text{ V}$ ,  $A_V = 0\text{ dB}$ ,  $V_{IN} = 0\text{ dBu} = 0.775\text{ V rms}$ ,  $f_{AUDIO} = 1\text{ kHz}$ ,  $f_{CLK} = 250\text{ kHz}$ ,  $R_L = 100\text{ k}\Omega$ ,  $-40^\circ\text{C} < T_A < +85^\circ\text{C}$ , unless otherwise noted. Typical specifications apply at  $T_A = +25^\circ\text{C}$ .)

Parameter	Conditions	Min	Typ	Max	Units
<b>AUDIO PERFORMANCE</b>					
Noise	$V_{IN} = \text{GND}$ , 20 kHz Bandwidth		-82		dBu
Headroom	Clip Point = 1% THD+N		+10		dBu
Total Harmonic Distortion Plus Noise	2nd and 3rd Harmonics Only				
	$A_V = 0\text{ dB}$		0.007	0.03	%
	$A_V = -20\text{ dB}$		0.02		%
	$A_V = 0\text{ dB}$ , $V_S = +5\text{ V}$ , Single Supply		0.035		%
<b>ANALOG INPUT</b>					
Input Impedance		7	10	15	k $\Omega$
<b>VOLUME CONTROL</b>					
Step Size	Relative to Same Channel		1.0		dB
Gain Error	0 dB Attenuation		0.1	1.0	dB
	-20 dB Attenuation		0.1		dB
	-40 dB Attenuation		0.25		
Gain Match Error	Channel-to-Channel; Same Level Setting				
	0 dB Attenuation		0.01		dB
	-20 dB Attenuation		0.05		dB
	-40 dB		0.4		dB
Mute Attenuation			64		dB
<b>ANALOG OUTPUT</b>					
Output Impedance			15		$\Omega$
Output Current			500		$\mu\text{A}$
Minimum Resistive Load	THD = 1%		4		k $\Omega$
Maximum Capacitive Drive			5000		pF
Offset Voltage	Channel Muted		50		mV
<b>CONTROL SECTION</b>					
Logic Input LO				0.8	V
Logic Input HI		2.0			V
Logic Input Current	Logic LO or HI		1		$\mu\text{A}$
Logic Out LO	$I_{OUT} = 0.2\text{ mA}$			0.4	V
Logic Out HI	$I_{OUT} = 0.2\text{ mA}$	2.4			V
Timing Characteristics	See Timing Diagram				
<b>REFERENCE (ACOM)</b>					
Output Voltage	$V_S = +10\text{ V}$ (Single Supply)	4.7	5.0	5.3	V
Output Impedance			10		$\Omega$
Load Regulation	$-0.5\text{ mA} \leq I_L \leq +0.5\text{ mA}$ (Single Supply)		0.2		%
<b>POWER SUPPLIES</b>					
Supply Voltage Range	Dual Supply	$\pm 4$		$\pm 7$	V
	Single Supply	+5		+14	V
Supply Current	$V_S = +10\text{ V}$ (Single Supply)		8	15	mA
Power Supply Rejection Ratio	Delta Gain		0.005		dB/V

Specifications subject to change without notice.

## Timing Description

Timing Symbol	Description	Min	Typ	Max	Units
$t_{CL}$	Input Clock Pulse Width	50			ns
$t_{CH}$	Input Clock Pulse Width	50			ns
$t_{DS}$	Data Setup Time	25			ns
$t_{DH}$	Data Hold Time	35			ns
$t_{CW}$	Positive CLK Edge to End of Write	25			ns
$t_{WC}$	Write to Clock Setup Time	35			ns
$t_{LW}$	End of Load Pulse to Next Write	20			ns
$t_{WL}$	End of Write to Start of Load	20			ns
$t_L$	Load Pulse Width	250			ns
$t_{W3}$	Load Pulse Width (3-Wire Mode)	250			ns
$t_{PD}$	Propagation Delay from Rising Clock to SDO Transition ( $R_L = 220\text{ k}\Omega$ , $C_L = 20\text{ pF}$ )	10	80	160	ns

## NOTES

1. An idle HI (CLK-HI) or idle LO (CLK-LO) clock may be used. Data is latched on the positive edge.
2. For SPI or microwire three-wire bus operation, tie  $\overline{LD}$  to  $\overline{WRITE}$  and use  $\overline{WRITE}$  pulse to drive both pins. (This generates an automatic internal  $\overline{LD}$  signal.)
3. If an idle HI clock is used,  $t_{CW}$  and  $t_{WL}$  are measured from the final negative transition to the idle state.
4. The first data byte selects an address (MSB HI), and subsequent MSB LO states set gain levels. Refer to the Address/Data Decoding Truth Table.
5. Data must be sent MSB first.

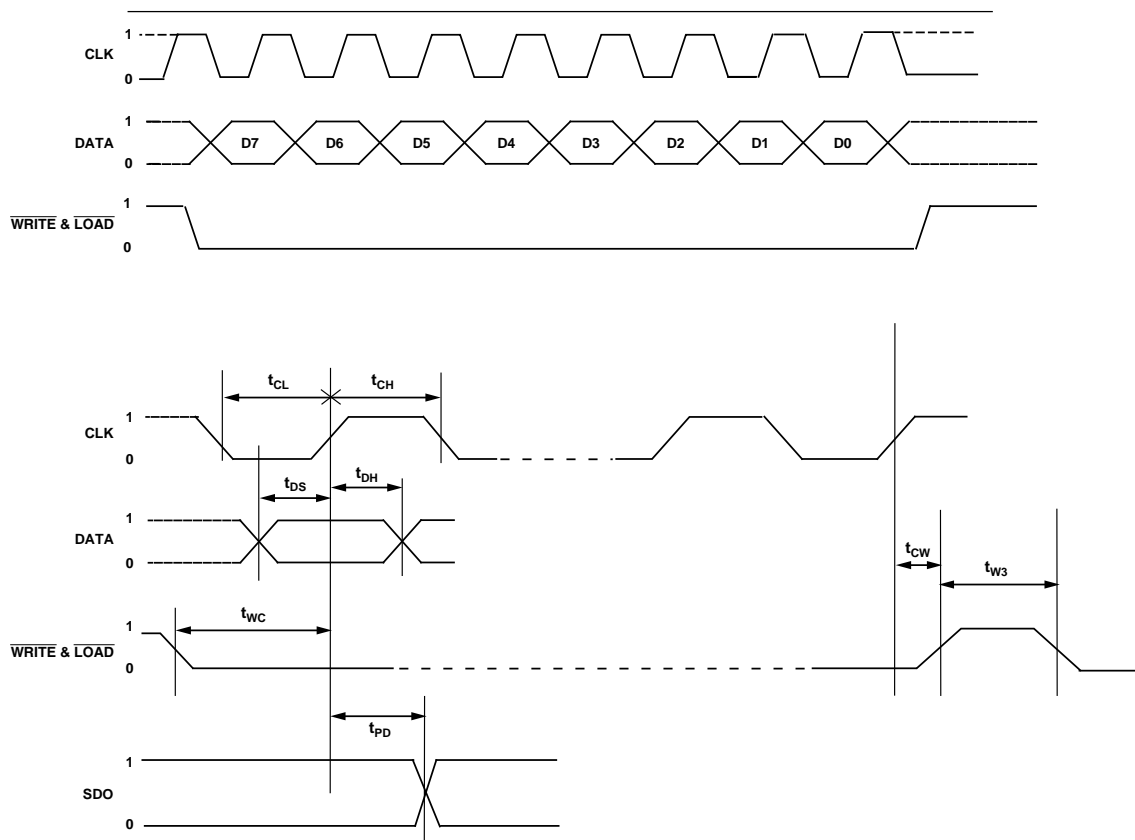

Figure 1. Three-Wire Mode Timing Diagram

# SSM2163

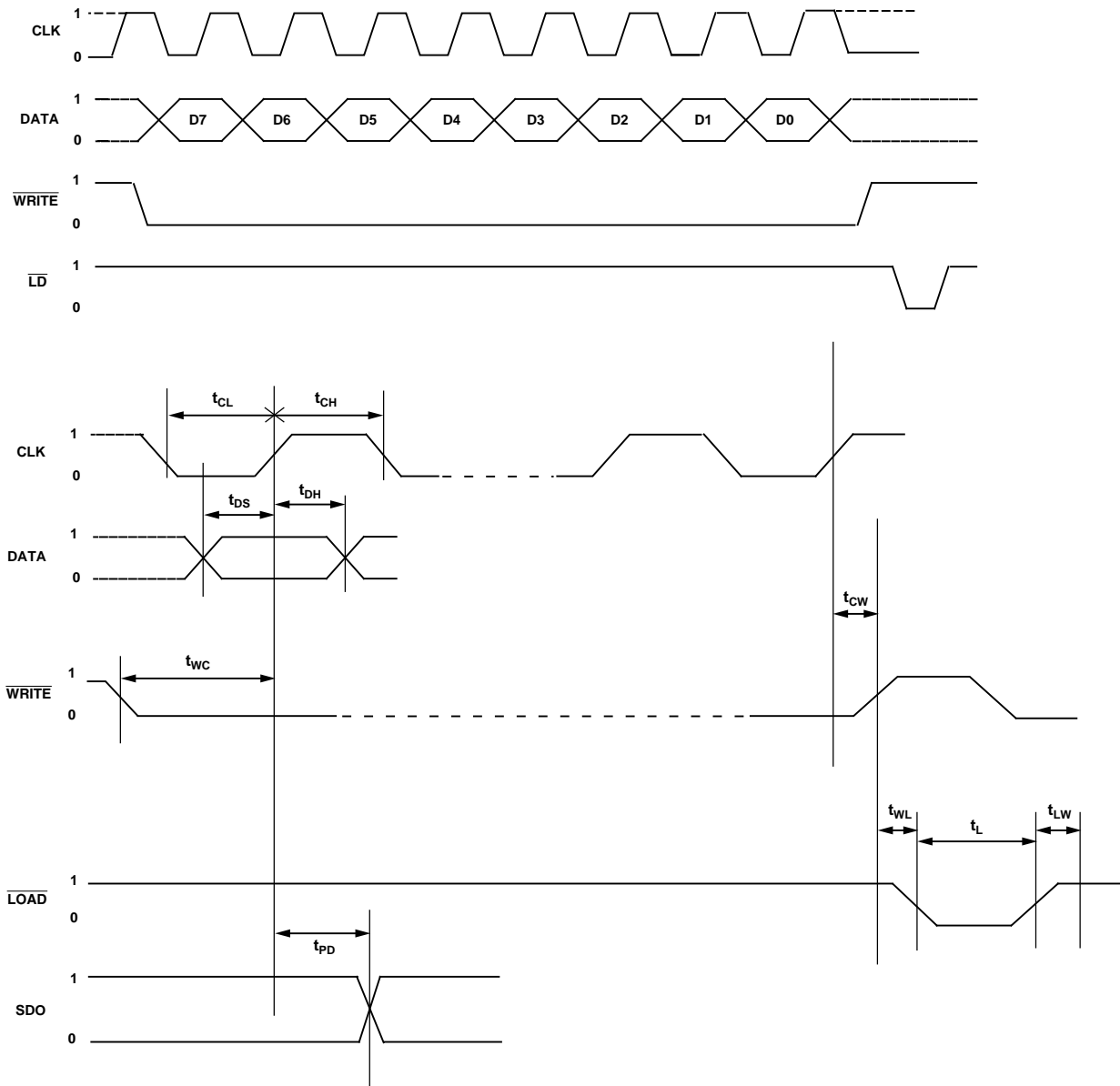

Figure 2. Four-Wire Mode Timing Diagram

**ABSOLUTE MAXIMUM RATINGS<sup>1</sup>**

Supply Voltage	
Dual Supply	±8 V
Single Supply	+16 V
Analog Input Voltage	±V <sub>S</sub>
Logic Input Voltage	±V <sub>S</sub>
Output Current	5 mA
Operating Temperature Range	-40°C to +85°C
Storage Temperature	-65°C to +150°C
Junction Temperature (T <sub>J</sub> )	+150°C
Lead Temperature (Soldering, 60 sec)	+300°C

**THERMAL CHARACTERISTICS**Thermal Resistance<sup>2</sup>

## 28-Pin Plastic DIP (SSM2163P)

θ <sub>JA</sub>	48°C/W
θ <sub>JC</sub>	22°C/W

## 28-Pin SOIC (SSM2163S)

θ <sub>JA</sub>	68°C/W
θ <sub>JC</sub>	20°C/W

**TRANSISTOR COUNT**

Number of Transistors . . . . . 1711 MOSFETs  
447 BJTs

**ESD RATINGS**

883 (Human Body) Model . . . . . 1000 V

## NOTES

<sup>1</sup>Stresses above those listed under "Absolute Maximum Ratings" may cause permanent damage to the device. This is a stress rating only and functional operation of the device at these or any other conditions above those indicated in the operation section of this specification is not implied. Exposure to absolute maximum rating conditions for extended periods may affect device reliability.

<sup>2</sup>θ<sub>JA</sub> is specified for worst-case conditions, i.e., θ<sub>JA</sub> is specified for device in socket for P-DIP and device soldered in circuit board for SOIC package.

**ORDERING GUIDE**

Model	Temperature Range	Package Description	Package Option
SSM2163P	-40°C to +85°C	Plastic DIP	N-28
SSM2163S	-40°C to +85°C	SOIC	R-28

**CAUTION**

ESD (electrostatic discharge) sensitive device. Electrostatic charges as high as 4000 V readily accumulate on the human body and test equipment and can discharge without detection. Although the SSM2163 features proprietary ESD protection circuitry, permanent damage may occur on devices subjected to high energy electrostatic discharges. Therefore, proper ESD precautions are recommended to avoid performance degradation or loss of functionality.

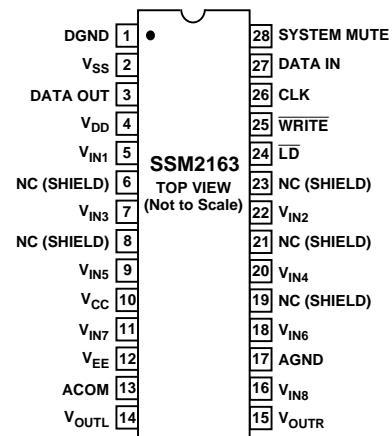
**PIN CONFIGURATIONS**  
Epoxy Plastic DIP (P-Suffix)  
and SOIC (S-Suffix)



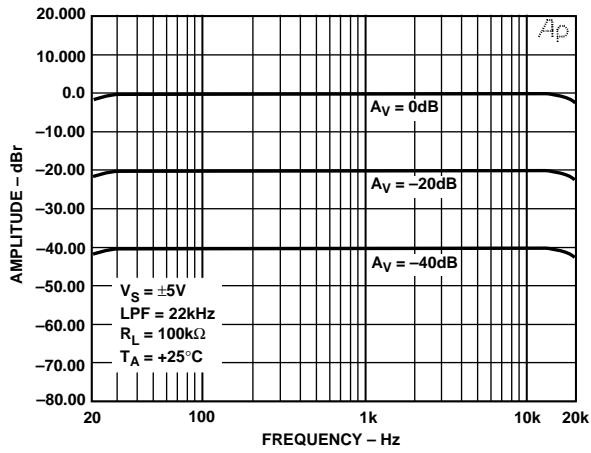

Figure 4. Frequency Response

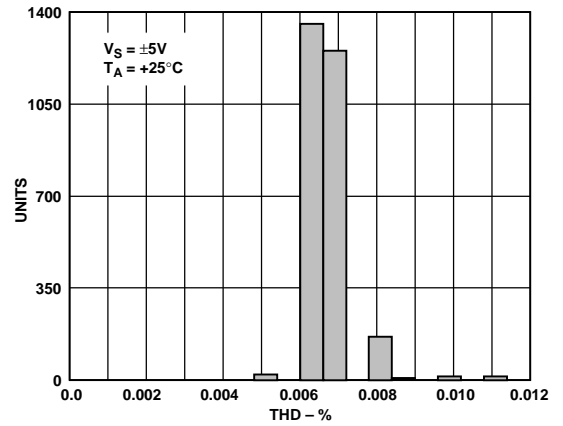

Figure 6. THD Distribution

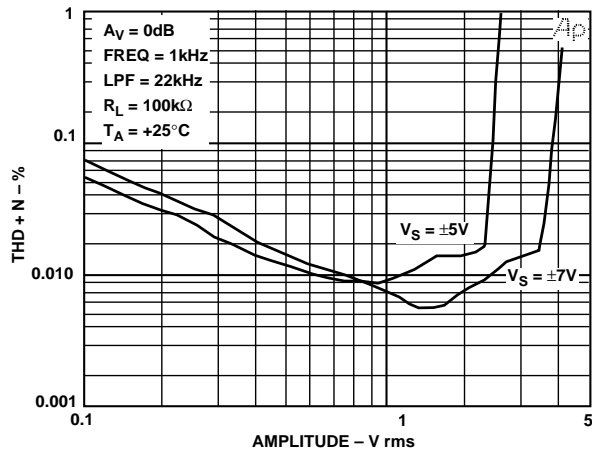

Figure 5. THD+N vs. Amplitude

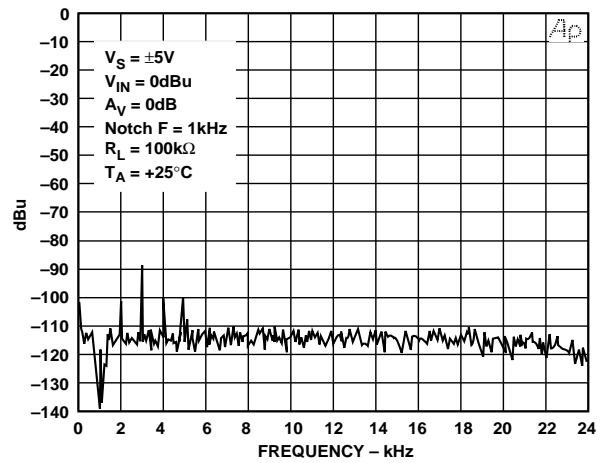

Figure 7. (THD+N) = 1 kHz Tone at 0 dBu (4k-Point FFT)

# SSM2163

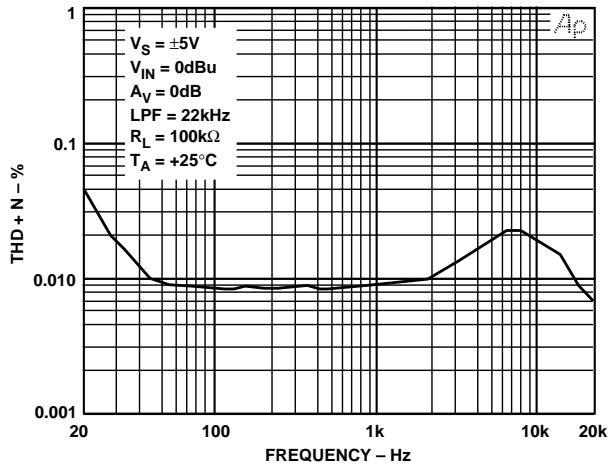

Figure 8. THD+N vs. Frequency

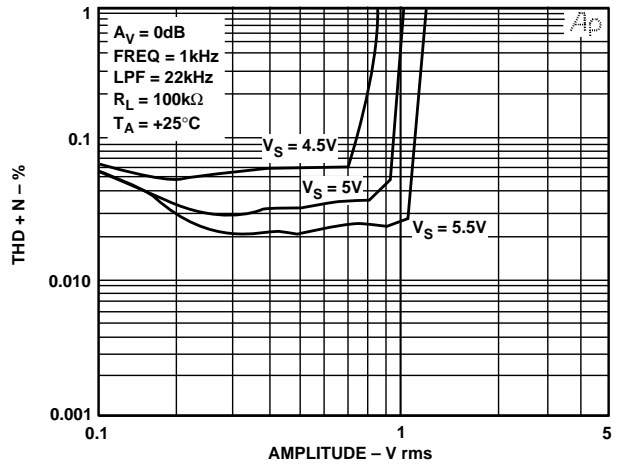

Figure 11. THD+N vs. Amplitude - Single Supply

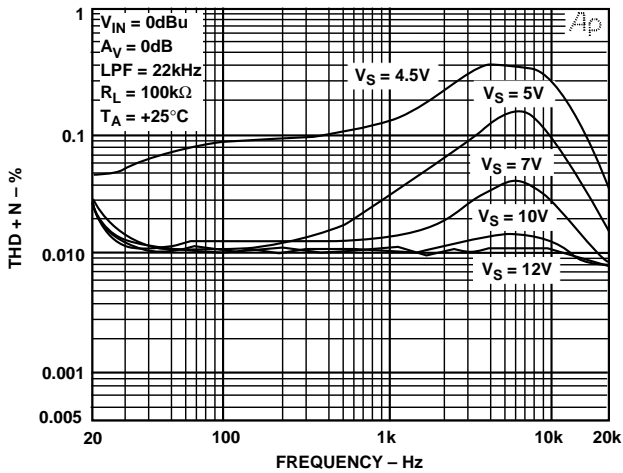

Figure 9. THD+N vs. Frequency - Single Supply

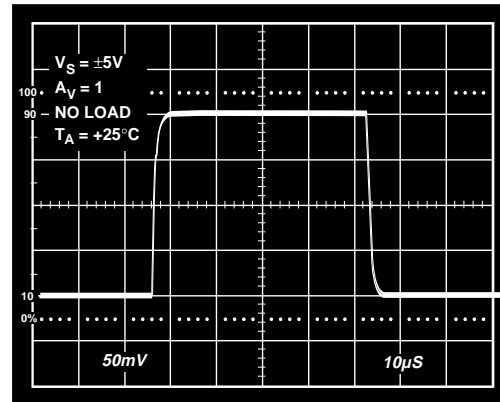

Figure 12. Small Signal Transient Response

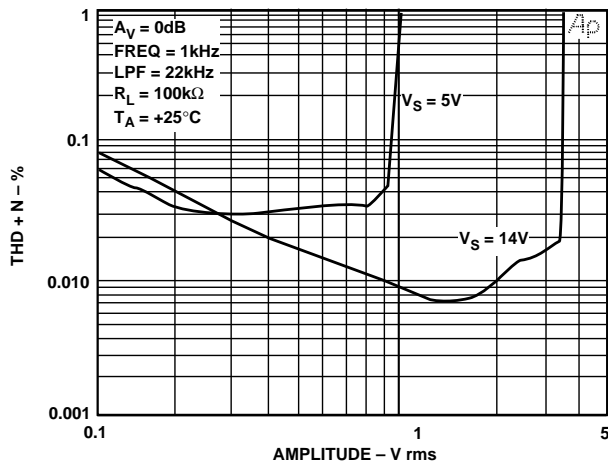

Figure 10. THD+N vs. Amplitude - Single Supply

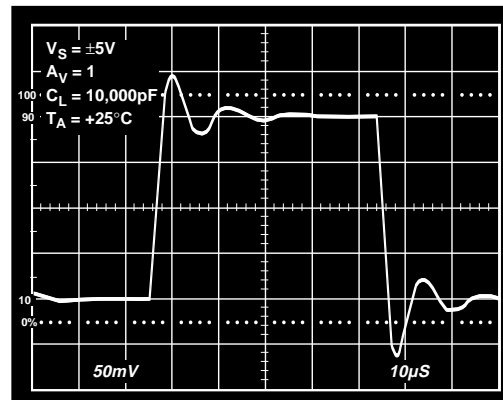

Figure 13. Small Signal Transient Response



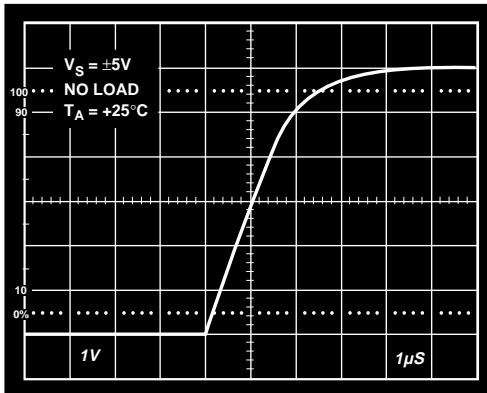

Figure 14. Large Signal Transient Response

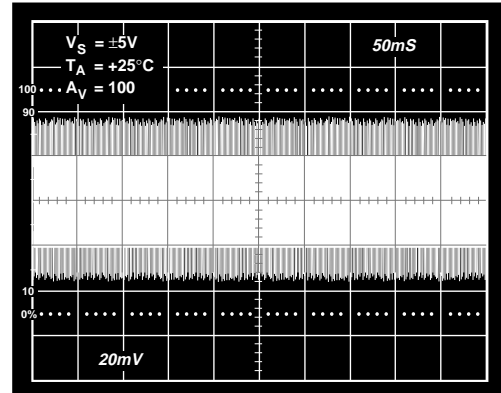

Figure 17. Broadband Noise

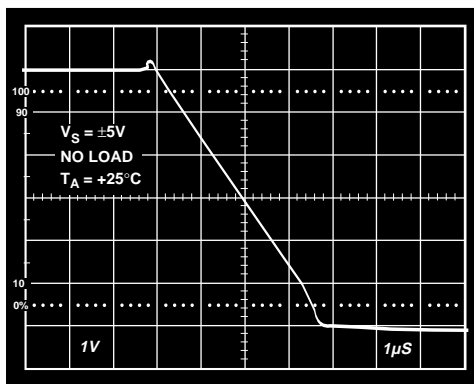

Figure 15. Large Signal Transient Response

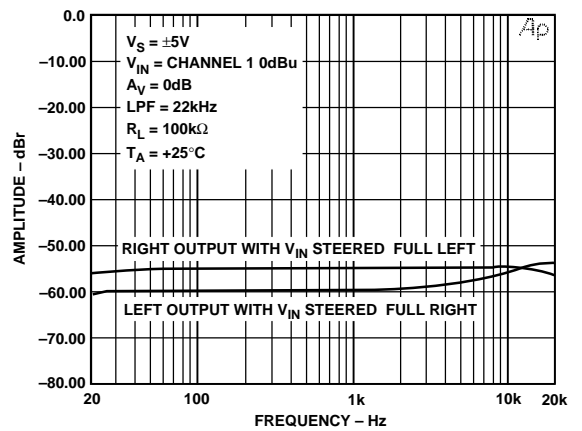

Figure 18. Output Channel Separation vs. Frequency

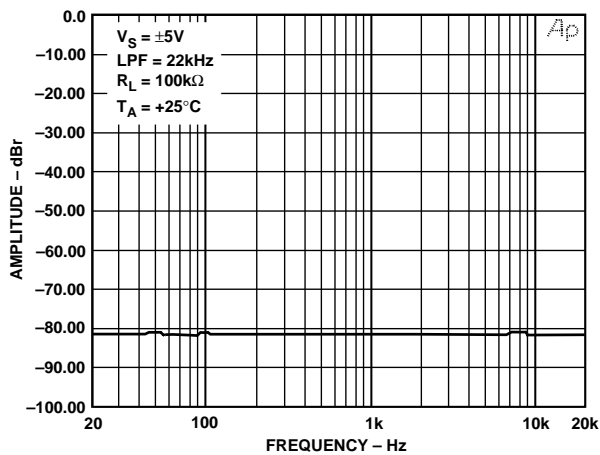

Figure 16. Noise Amplitude vs. Frequency

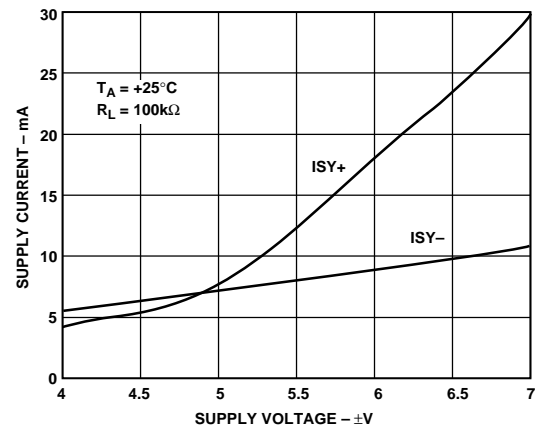

Figure 19. Supply Current vs. Supply Voltage

# SSM2163

## THEORY OF OPERATION

The SSM2163 is an eight-input, two-output audio mixer and attenuator. The device provides eight analog inputs, each of which can be individually attenuated by 0 dB to 63 dB in 1 dB steps (see the SSM2163 simplified block diagram). The eight signals can then be mixed into one or both of two analog outputs. The channel attenuation level and mixer functions are controlled by digital registers, which are loaded via a serial interface. A hardware mute input is included to asynchronously force all inputs into the muted state.

### Analog Section

The analog signal path is shown in Figure 20. Each analog input has a nominal impedance of 10 kΩ. Each input therefore appears as a digitally programmable 10 kΩ potentiometer. The SSM2163 input impedance remains constant as the attenuation level changes. Therefore, the sources which drive the SSM2163 do not have to drive complex and variable impedances.

The attenuated analog input is applied to the left and right channel inputs of the mixer. Each mixer channel consists of an analog switch and a buffer amplifier. If the channel is selected (via the appropriate bit in the mixer control register), the analog switch is turned on. The buffer amplifier is included after the analog switch so that the gain of each channel will not be affected by the potentiometer setting or by the on-resistance (RDS(ON)) of the switch.

Each mixer channel which is ON is then summed into its respective (Left or Right) mixer summing amplifier. (If both of the mixer channels are ON, then the attenuated analog input will be applied to both the Left and Right summing amplifiers.) The buffered output of the summing amplifier will supply ±500 μA to an external load.

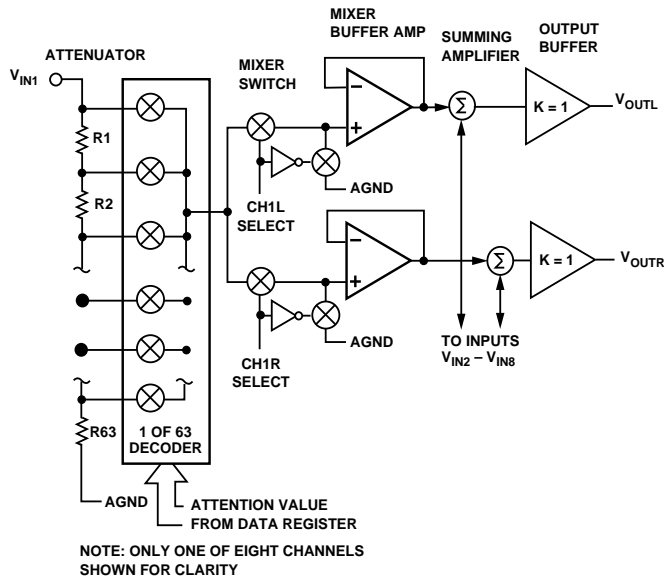

Figure 20. SSM2163 Analog Signal Path

### Digital Interface

The digital interface consists of two banks of 8 data registers with a serial interface (Figure 21). One register bank holds the left/right mixer control bits, while the other register bank holds the 6-bit attenuator value.

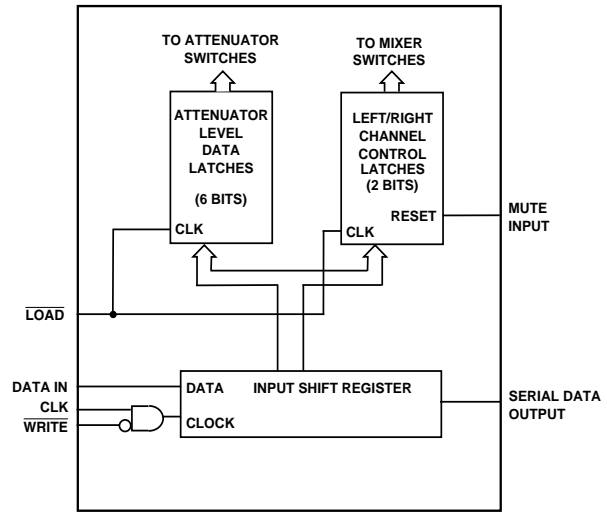

Figure 21. SSM2163 Serial Data Interface Block Diagram

To access the SSM2163, the host controller (typically a micro-computer) writes a value to the serial shift register which selects the appropriate input channel register for subsequent attenuator-load operations. This write operation also controls the left and right mixer switches. The next write operation then loads the 6-bit attenuator level into the appropriate register. If a series of values are going to be written to the same address, for instance when fading a channel, then only one write operation to the address register is required.

### Serial Data Control Inputs

The SSM2163 provides a simple 3- or 4-wire serial interface (Figures 22 and 23). Data is input on the DATA IN pin, while CLK is the serial clock. Data can be shifted into the SSM2163 clock rates up to 1 MHz.

The shift register clock, CLK, is enabled when the WRITE input is low. The WRITE pin can therefore be used as a chip select input. However, the shift register contents are not transferred to the register banks until the rising edge of LOAD. In most cases, WRITE and LOAD will be tied together, forming a traditional 3-wire serial interface. See the Microcomputer Interfaces section of this data sheet for more information.

To enable a data transfer, the WRITE and LOAD inputs are driven low. The 8-bit serial data, formatted MSB first, is input on the DATA IN input and clocked into the shift register on the rising edge of CLK. The data is latched on the rising edge of WRITE and LOAD. If the data is an address, then the mixer control is updated. If the data is an attenuator value the rising edge of WRITE and LOAD will update the appropriate attenuator value.

### MUTE Input

The MUTE pin provides a hardware input to force all the SSM2163 channels into the muted state. The MUTE input is active HIGH. Most μC I/O pins are in a high impedance state or configured as inputs at power-up, so the SSM2163 will automatically be muted at power-up. A 10 kΩ resistor to +5 V is recommended, to ensure that MUTE is pulled high reliably. The MUTE input can also be driven from a μC's RESET signal to force a power-on mute.

In addition to power-on, the MUTE input can be used to asynchronously mute all channels at any time. The mute function of the SSM2163 does not affect the attenuator values

## SSM2163 power supply connections

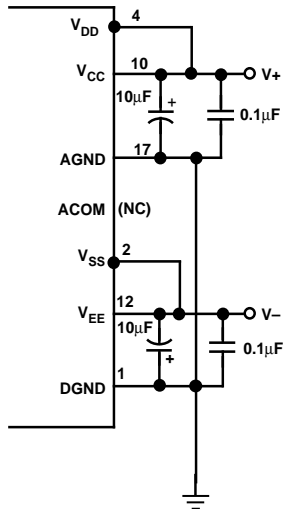

Figure 22a. Dual Supply

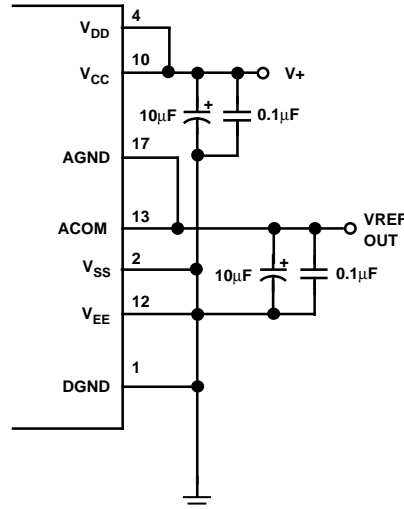

Figure 22b. Single Supply

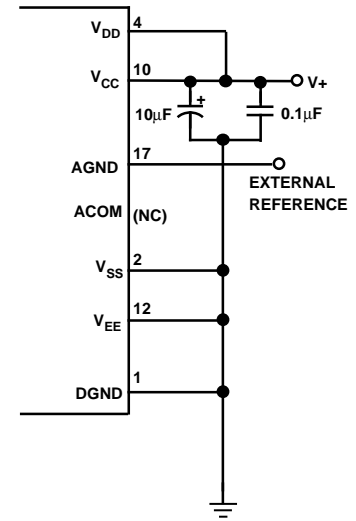

Figure 22c. Single Supply Using External Reference

stored in the attenuator control registers. To re-enable the system after a mute, use the address byte to turn on the desired mixer channel. The selected channel will then operate with the previously set attenuator value.

### Serial Data Input Format

As previously mentioned, data is written to the SSM2163 in two 8-bit bytes. The serial data format is shown in the Address and Data Decoding Truth Table, Figure 3. The first byte sent contains the channel address and the Left/Right output mixer control bits. The address byte is identified by the MSB being high.

The second byte contains the data (i.e., the attenuator value). The six LSBs of this byte set the attenuation level, from 0 dB to -63 dB. The MSB of the data byte must be a logic zero.

The standard format for data sent to the SSM2163 is an address byte followed by a data (attenuator level) byte. In some cases, however, only one byte needs to be sent. For example, attenuation levels are not affected by the MUTE input. To turn a muted channel on, simply send an address byte with the Left or Right mixer bit set. The addressed channel will immediately be enabled, using the previously-set attenuation level. Furthermore, once a channel is addressed the attenuation level can be varied by sending additional data bytes. For example, fading a channel can be accomplished by simply incrementing the data value sent to the SSM2163.

### Serial Data Output

The MSB of the shift register is available on the serial DATA OUTPUT pin. This output can be connected to the input of another SSM2163 to permit "daisy-chain" operation. See Figure 26 for a typical application. The DATA OUTPUT pin swings between the digital power supply rails (i.e., from  $V_{DD}$  to  $V_{SS}$ ).

### Logic Levels

All of the SSM2163 logic inputs have TTL and CMOS compatible thresholds. However, the allowable voltage range for these inputs extends from  $V_{DD}$  to  $V_{SS}$ .

### Power Supplies and Decoupling

The SSM2163 operates from either single or dual (split) power supplies. In either case, proper supply decoupling is important to maximize audio performance.

To reduce noise, separate pins are provided for the digital and analog power supply connections. These pins should be connected together ( $V_{DD}$  to  $V_{CC}$  and  $V_{EE}$  to  $V_{SS}$ ) as close to the SSM2163 package as possible (Figures 22a, 22b, 22c, power supply connections).

### Single Supply Operation

The SSM2163 will operate with a single power supply of +5 V to +14 V. Single supply operation simplifies design and reduces system cost in multimedia applications, battery powered systems, and similar designs. The SSM2163 provides about 2 dB of headroom (to 1% THD+N) when operating from a single +5 V supply.

The key to operating from a single supply is to reference all analog common connections to a voltage midway between the supply and ground. To simplify single supply operation, the SSM2163 provides a buffered pseudo-ground reference (ACOM) on Pin 13. This reference, shown in Figure 23, provides a low impedance output at approximately one half of the supply voltage. Connect Analog Ground (Pin 17) to the ACOM output (Pin 13) for single supply operation. To minimize noise caused by modulation of the pseudo-ground, Pin 13 should be bypassed to power supply ground with 0.1  $\mu$ F and 10  $\mu$ F capacitors.

# SSM2163

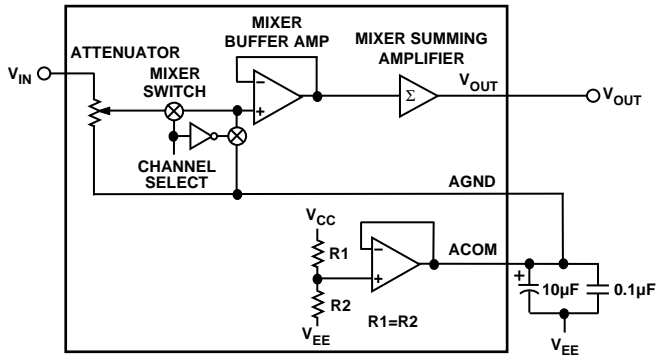

Figure 23. Single-Supply Pseudo-Ground Reference (ACOM) Generator

For single supply operation, the inputs can either be ac-coupled, as shown in Figure 25, or referenced to the pseudo-ground output. AC coupling eliminates dc offset and offset drift differentials between the input source and the SSM2163. In addition, ac coupling reduces the risk of “clicks” when switching between multiple dc-coupled inputs which have different reference levels.

Since the input coupling capacitors are in series with the 10 kΩ input of the attenuator, the impedance of these capacitors will influence low frequency gain. The inexpensive 10 µF aluminum electrolytic capacitors shown will limit the gain error to 0.66 dB at 20 Hz.

If the entire system is operating from a single supply, then typically the input voltage is already referenced to the midpoint of the supply. In this case, the SSM2163 can be referenced to the same midpoint reference source, as shown in Figure 22c. This connection will eliminate dc offset errors caused by having the input signal common and the SSM2163 analog common referenced to different voltages. DC offset errors can also be eliminated, of course, by using the ac coupling technique discussed above.

### Dual-Supply Operation

The SSM2163 will also operate from dual supplies, ranging from ±4 V to ±7 V. (See Figure 22a.) In this case, input signals can be referenced to power supply ground. The ACOM output (Pin 13) is left open (no connection) for dual supply operation.

### Supply Decoupling

Optimizing the performance of the SSM2163, or any low noise device, requires careful attention to power supply decoupling. Since the SSM2163 can operate from a single +5 V supply, it seems convenient to simply tap into the digital logic power supply. Unfortunately, the logic supply is often a switch-mode design, which generates noise in the 20 kHz to 1 MHz range. In addition, fast logic gates can generate glitches hundred of millivolts in amplitude due to wiring resistances and inductances.

If a separate analog power supply is not available, the SSM2163 can be powered directly from the system power supply. Separate power and ground traces should be provided for the analog section, if possible. This arrangement, shown in Figure 24, will isolate the analog section from the logic switching transients. Even if a separate power supply trace is not available, however, generous supply bypassing will reduce supply line induced noise. Local supply bypassing, consisting of a 10 µF tantalum electrolytic in parallel with a 0.1 µF ceramic capacitor, is recommended in all applications. (See the SSM2163 Power Supply Connections figures.)

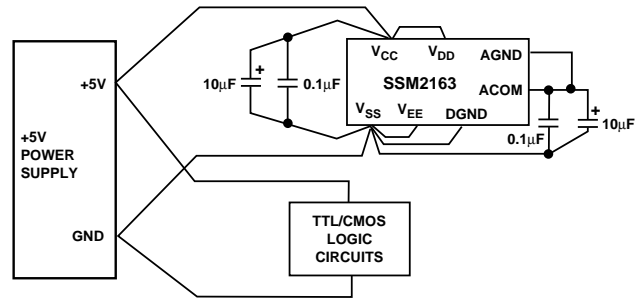

Figure 24. Use Separate Traces to Reduce Power Supply Noise

Even if the system includes separate analog and digital power supplies, both the analog and digital power pins of the SSM2163 should be connected to the analog supply. While this connection will inject a small amount of digital noise into the analog ground, the effect is small due to the SSM2163’s low digital logic input currents and capacitances. If, on the other hand, the SSM2163’s digital supply pins are connected to a digital power supply, then noise from the digital supply will be coupled into the SSM2163 and degrade performance.

## APPLICATIONS

### An 8-Input, 2-Output Mixer

A single-chip, 8-input, 2-output mixer using the SSM2163 is shown in Figure 25. With this circuit, any of the eight channels can be attenuated by 0 dB to -63 dB and mixed into the right, left, or both outputs under software control.

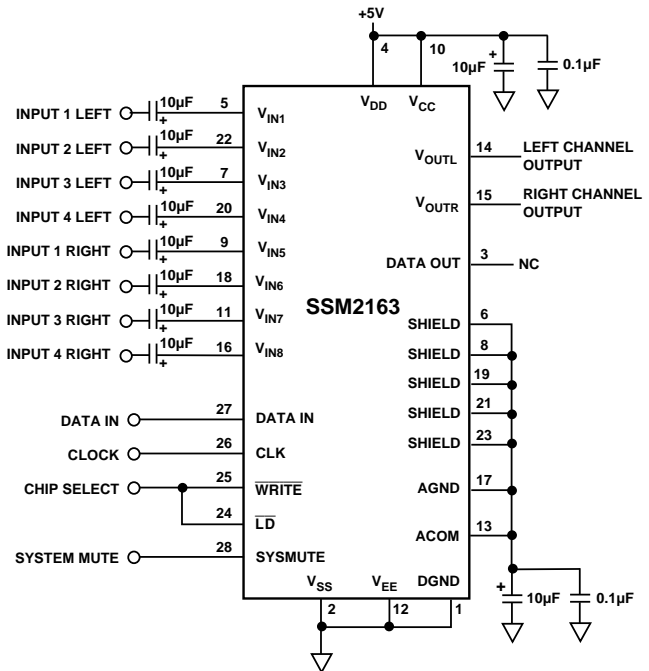

Figure 25. An 8-Input, 2-Output Mixer

This circuit demonstrates ac coupling of the inputs. As previously mentioned, this eliminates level shifting concerns from previous stages.

The circuit of Figure 25 also demonstrates single +5 V supply operation. The output of the ACOM supply-splitter, Pin 13, provides the pseudo-ground reference which is required when operating from a single supply.

### Mixing Additional Channels

Some mixing applications require more than four inputs for each stereo channel. To meet the requirements of these systems, two or more SSM2163s can be paralleled to provide additional channels. A typical circuit is shown in Figure 26, which combines two SSM2163s to form a 16-input, 2-output mixer. An SSM2135 dual audio op amp sums the outputs of each of the SSM2163s. With this system, any of the 16 inputs can be mixed into either or both of the output channels.

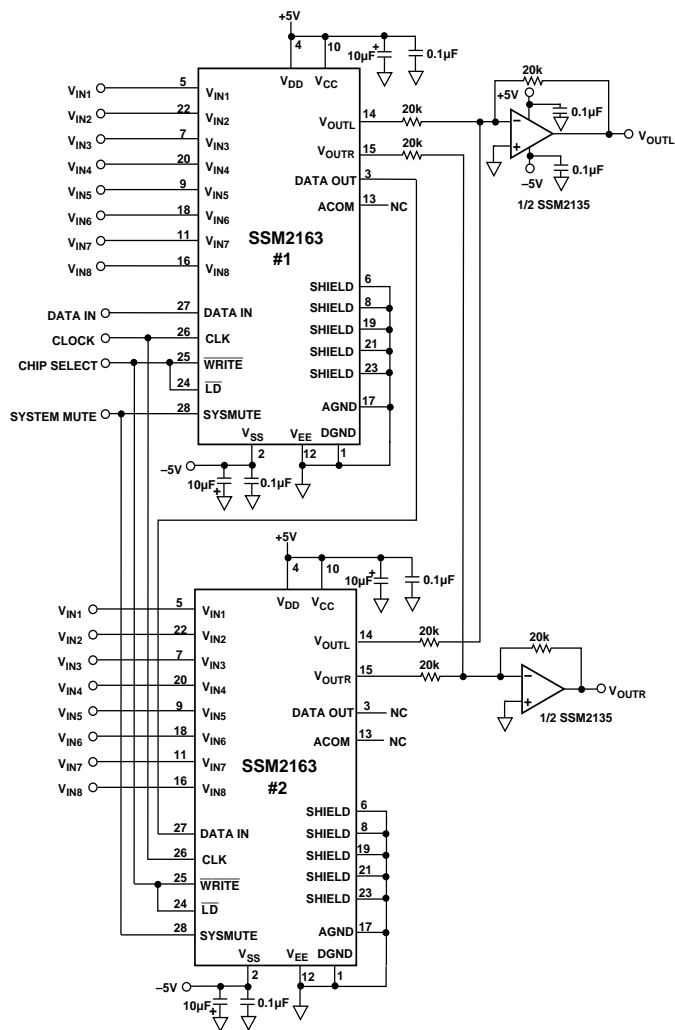

Figure 26. A 16-Input, 2-Output Mixer

This circuit utilizes the DATA OUT feature of the SSM2163 to transfer data from the first SSM2163 to the second. In the daisy-chain mode, the DATA OUT pin of the first SSM2163 is connected to the DATA IN pin of the second device. The advantage of this “daisy chain” connection is that it allows a 3-wire serial interface, as was used in the previous 8-input mixer, to control two or more SSM2163s.

The serial data format for the daisy chain circuit is similar to the 8-channel application, except that the SSM2163s are loaded in tandem. After setting WRITE and LOAD low, two bytes (16 bits) are clocked into the first SSM2163. When WRITE and LOAD return high, data will be latched into both SSM2163s simultaneously.

The circuit of Figure 26 illustrates dc coupling of the inputs. DC coupling is practical with dual supplies and ground-referenced inputs, because the dc offsets associated with single-supply operation are reduced. However, ac coupling could also be used, and employing both ac- and dc-coupled signals in one mixer is also possible. In addition, this circuit illustrates the connections for  $\pm 5$  V power supplies. Note that the negative supply, as well as the positive supply, should be bypassed to ground.

### Implementing a Software-Controlled Pan-Pot

Pan and fade effects are important attributes of modern multimedia presentations and similar applications. One way to achieve these effects is to apply the input signal to two input channels of the SSM2163, as shown in Figure 27. Since any input channel can be mixed into either or both outputs, sophisticated pan and fade effects are easily accomplished in software. For example, Input 1 can be connected to the left channel with 0 dB attenuation, while Input 2 is applied to the right channel with  $-10$  dB of attenuation. This configuration will produce the effect of having the audio source “located” to the left of center line of the speakers. Another possible option would be to attenuate the left channel while boosting the right, which would produce an effect of movement of the audio source. Since any input can be connected to either output, very flexible and sophisticated effects can be produced without hardware changes.

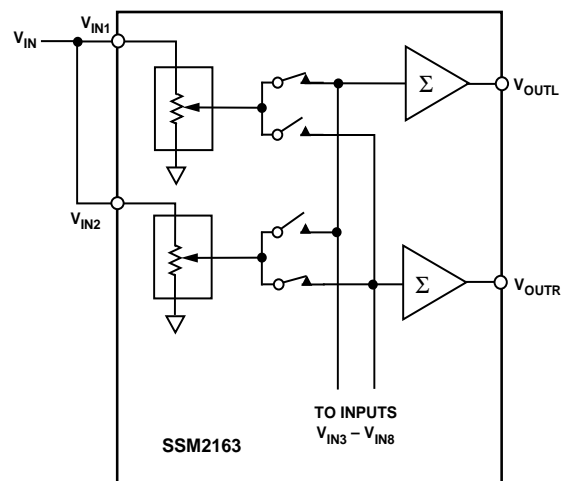

Figure 27. Connecting the SSM2163 for Pan-Pot Operation

### Driving Headphones

A high speed, high output current amplifier, such as the OP279, can be added to drive headphones directly. A typical connection is shown in Figure 28. Single  $+5$  V operation is maintained, since the OP279 offers rail-to-rail inputs and outputs. The OP279’s high current output stage can drive a  $48 \Omega$  load to 4 V p-p while maintaining less than 1% THD.

# SSM2163

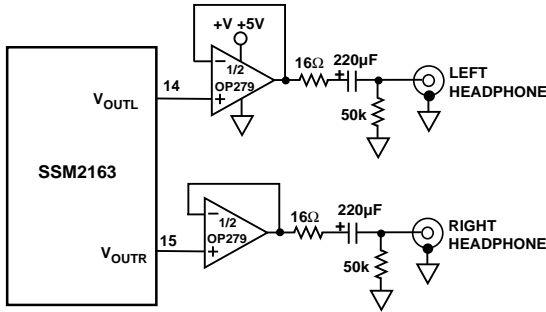

Figure 28. A Single-Supply Stereo Headphone Driver

The op amp's input offset voltage is only 4 mV maximum, so the SSM2163 output can be dc coupled. The headphone output is ac coupled through a 220 μF capacitor. The large coupling capacitor is required because of the low impedance of the headphones, which can range from 32 Ω to 600 Ω. An additional 16 Ω resistor is used in series with the output capacitor to protect the op amp's output stage by limiting capacitor discharge current.

### Microcomputer Interfaces

The SSM2163 serial data input provides an easy interface to a variety of single chip microcomputers (μCs). Many μCs have a built-in serial data capability which can be used for communicating with the SSM2163. In cases where no serial port is provided, or it is being used for some other purpose (such as an RS-232 communications interface), the SSM2163 can easily be addressed in software.

The SSM2163 can operate in either a 3-wire or 4-wire mode. In most cases, the 3-wire mode is more practical, due to reduced PC board traces and compatibility with μC serial interface protocols. A typical interface, using the 80C51 μC, is shown in Figure 29, while the interface waveforms are shown in the Timing Diagram, 3-Wire Mode, Figure 1.

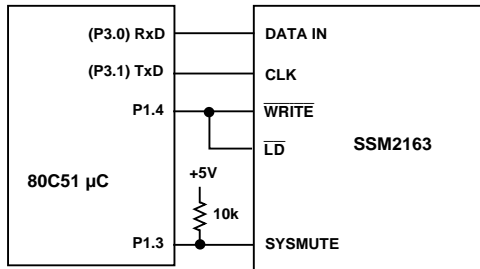

NOTE: ADDITIONAL PINS OMITTED FOR CLARITY

Figure 29. Interfacing the 80C51 μC to an SSM2163 in 3-Wire Mode

### Port in 4-Wire Mode

In some cases, it may be desirable to synchronize the outputs of several SSM2163s. The 4-wire mode, shown in Figure 30, provides this capability. As shown in Figure 2, the Timing Diagram, 4-Wire Mode, the input shift register is loaded with data while the  $\overline{\text{WRITE}}$  input is low. However, the data will not be latched into the SSM2163's internal registers until the rising edge of the LOAD input. In this manner, any number of SSM2163s can be loaded with data, while the amplitude and mixer changes will not occur until the separate LOAD pulse occurs.

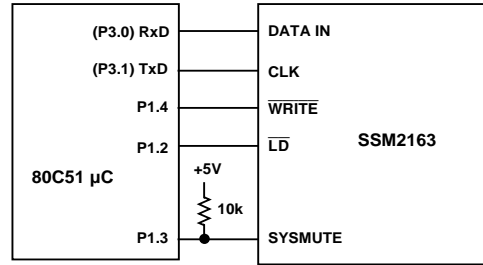

NOTE: ADDITIONAL PINS OMITTED FOR CLARITY

Figure 30. Interfacing the 80C51 μC to an SSM2163 in 4-Wire Mode

### An 80C51 μC Interface

A typical interface between the SSM2163 and an 80C51 μC is shown in Figure 30. This interface uses the 80C51's internal serial port. The serial port is programmed for Mode 0 operation, which functions as a simple 8-bit shift register. The 80C51's Port 3.0 pin functions as the serial data output, while Port 3.1 serves as the serial clock.

When data is written to the serial buffer register (SBUF, at Special Function Register location 99H), the data is automatically converted to serial format and clocked out via Port 3.0 and Port 3.1. After 8 bits have been transmitted, the Transmit Interrupt flag (SCON.1) is set and the next 8 bits can be transmitted.

The 80C51 transmits serial data in Least Significant Bit (LSB)-first format. The SSM2163, on the other hand, requires data in MSB format. A BYTESWAP routine swaps the order of the bits before transmission.

The SSM2163 requires the Chip Select to go low at the beginning of the serial data transfer. After each 8 bits (either address or attenuation value) are transmitted, Chip Select must go high to latch data into the appropriate register. Chip Select is controlled by the 80C51's port 1.4 pin.

### Software for the 80C51 Interface

A software routine for the SSM2163 to 80C51 interface is shown in Listing 1. The routine transfers the 6-bit attenuation level stored at data memory location LEVEL\_VALUE to the SSM2163 input addressed by the contents of location INPUT\_ADDR, and turns the Left and/or Right mixer channels on/off based on bits 3 and 4 of INPUT\_ADDR.

Listing 1. Software for the 80C51-SSM2163 Serial Port Interface

```

; This subroutine loads an SSM2163 mixer channel with a 6-bit
; attenuator value, and turns the Left or Right mixer switch ON or OFF.
; The attenuator value is stored at location ATTEN_VALUE
; The mixer channel address is stored at location INPUT_ADDR
;
PORT1      DATA      90H                ;SFR register for port 1
ATTEN_VALUE DATA      40H                ;Attenuation level (0=0dB)
          ;ATTEN-VALUE: B7=0, B5-B0=Attenuation Value
INPUT_ADDR DATA      41H                ;Mixer Channel Address
          ;INPUT_ADDR: B7=1, B4=L chnl, B3=R chnl, B2-B0=address
LOOPCOUNT DATA      42H                ;Count loops for byte swap
SHIFTREG   DATA      43H                ;Shift reg. for byte swap
SENDBYTE    DATA      44H                ;Destination reg. for byte swap
;
LD_2163:   ORG         100H                ;arbitrary starting address
          CLR         SCON.7                ;set serial
          CLR         SCON.6                ; data mode 0
          CLR         SCON.5                ;Clr SM2 for mode 0
          CLR         SCON.1                ;clr the transmit flag
          CLR         PORT1.3                ;Mute function off
          SETB        PORT1.4                ;WRITE and LOAD High
          MOV         SHIFTREG,INPUT_ADDR    ;Get mixer channel address
          ACALL       SEND_IT                ; send to SSM2163
SEND_VAL:  MOV         SHIFTREG,ATTEN_VALUE ;Get the attenuation level
          ACALL       SEND_IT                ; send it to the SSM2163
          RET                                     ;Done
;
          ;Convert the byte to LSB-first format and send
          ; it to the SSM2163
SEND_IT:   MOV         LOOPCOUNT,#8        ;Shift 8 bits
BYTESWAP: MOV         A,SHIFTREG            ;Get source byte
          RLC         A                      ;rotate MSB to carry
          MOV         SHIFTREG,A            ;Save new source byte
          MOV         A,SENDBYTE            ;get destination byte
          RRC         A                      ;Move carry into MSB
          MOV         SENDBYTE,A            ;Save
          DJNZ        LOOPCOUNT,BYTESWAP   ;Done?
          CLR         PORT1.4                ;Set WRITE and LOAD low
          MOV         SBUF,SENDBYTE         ;Send the byte
SEND_WAIT: JNB        SCON.1,SEND_WAIT      ;Wait until 8 bits are send
          CLR         SCON.1                ;Clear the serial flag
          SETB        PORT1.4                ;Set WRITE and LOAD high to latch
          RET                                     ; data into the SSM2163
          END

```

The subroutine begins by setting appropriate bits in the Serial Control register to configure the serial port for Mode 0 operation. Next the SSM2163's Chip Select input is set low to enable the SSM2163. The input channel address is obtained from memory location INPUT\_ADDR, adjusted to compensate for the 80C51's serial data format, and moved to the serial buffer register. At this point, serial data transmission begins automatically. When all 8 bits have been sent, the Transmit Interrupt bit is set, and the Chip Select output is set high to latch the channel address into the SSM2163. The subroutine then sets Chip Select low again and proceeds to send the attenuation value stored at location LEVEL\_VALUE. When the Chip Select input is returned high, the appropriate SSM2163 input channel will be updated with the new attenuation value and the subroutine ends.

The 80C51 sends data out of its shift register LSB first, while the SSM2163 requires data MSB first. The subroutine therefore includes a BYTESWAP subroutine to reformat the data. This routine transfers the MSB-first byte at location SHIFTREG to an LSB-first byte at location SENDBYTE. The routine rotates the MSB of the first byte into the carry with a Rotate Left Carry instruction, then rotates the carry into the MSB of the second byte with a Rotate Right Carry instruction. After 8 loops, SENDBYTE contains the data in the proper format.

The BYTESWAP routine in Listing 1 is convenient because the attenuator data can be calculated in normal LSB form. For example, fading a channel on the SSM2163 is simply a matter of repeatedly incrementing the LEVEL\_VALUE location and calling the SEND\_VAL subroutine. (Remember, the 6-bit

# SSM2163

number stored in LEVEL\_VALUE is the attenuation value, expressed in -dB, so larger values will decrease volume. Also, the register must not be allowed to increment beyond 7FH because the MSB will be set and the SSM2163 will interpret the value as an address. Therefore, the two highest bits of LEVEL\_VALUE should be cleared by ANDing the register with 3FH.)

If the  $\mu\text{C}$ 's hardware serial port is being user for other purposes, the SSM2163 can be loaded by using the parallel port. A typical parallel interface is shown in Figure 31. The serial data is transmitted to the SSM2163 via the 80C51's Port 1.6 output, while Port 1.5 acts as the serial clock.

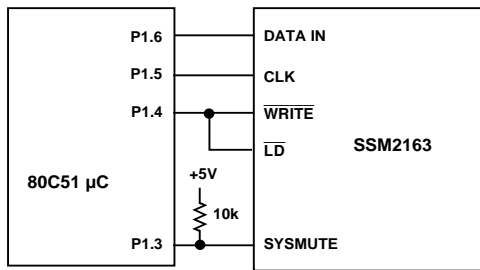

NOTE: ADDITIONAL PINS OMITTED FOR CLARITY

Figure 31. An SSM2163 to 80C51  $\mu\text{C}$  Interface Using Parallel Port 1

Software for the interface of Figure 31 is straightforward. Typically, the  $\mu\text{C}$  will repeatedly shift the value to be sent, for example from register LEVEL\_VALUE, into the carry bit. Port P1.6 is then set or reset based on the carry bit, and Port P1.5 is strobed low and then high to create a clock pulse. After eight loops, the value will have been sent to the SSM2163. Note that all eight bits should be sent, even though only six bits are significant. If only six bits are shifted in, the two low order bits of the previous value will remain in the MSBs of the shift register. If this action results in the MSB being a one, the SSM2163 will interpret this as an address and unpredictable results will occur.

## OUTLINE DIMENSIONS

Dimensions shown in inches and (mm).

### 28-Pin Plastic DIP (N-28)

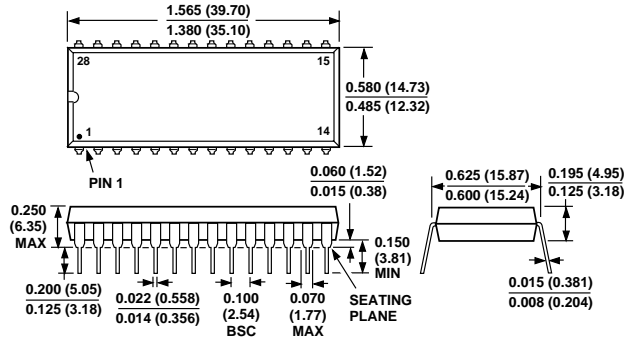

### 28-Pin SOIC (R-28)

