

FEATURES

- Ultra thin type with height 1.4mm Max.
- SMD type suitable for automatic & high density surface mounting.
- Plastic mold package containing highly reliable tubular type quartz crystal.
- Excellent shock and heat resistance.
- RoHS compliant.

APPLICATIONS

- Cellular Phones, PDA, DVC, Radio Communication Equipment, Portable Applications etc.

Under Development

Scheduled to be complete Pb-free in June, 2006

STANDARD SPECIFICATIONS

Conditions without notice (Temperature: +25±2°C, DL: 0.1μW)

Item	Symbol	Specifications	Conditions / Notes
Nominal Frequency	f_nom	32.768kHz	
Frequency Tolerance	f_tol	±20 x 10 ⁻⁶ , ±50 x 10 ⁻⁶	
Turnover Temperature	Ti	+25±5°C	
Parabolic Coefficient	B	(-3.5±1.0) x 10 ⁻⁸ /°C ²	
Load Capacitance	CL	7.0 pF / 12.5pF	
Motional Resistance (ESR)	R1 typ./max.	44kΩ / 65kΩ	
Absolute Maximum Drive Level	DLmax	1μW	
Level of Drive	DL	0.1μW	
Shunt Capacitance	C ₀	0.8pF typ.	
Frequency Ageing	f_age	±3 x 10 ⁻⁶	+25±3°C, First Year
Operating Temperature	T_use	-40°C to +85°C	
Storage Temperature	T_stg	-55°C to +125°C	Store a pcs. part

DIMENSIONS

(For details, please refer to individual specification)

UNIT: mm

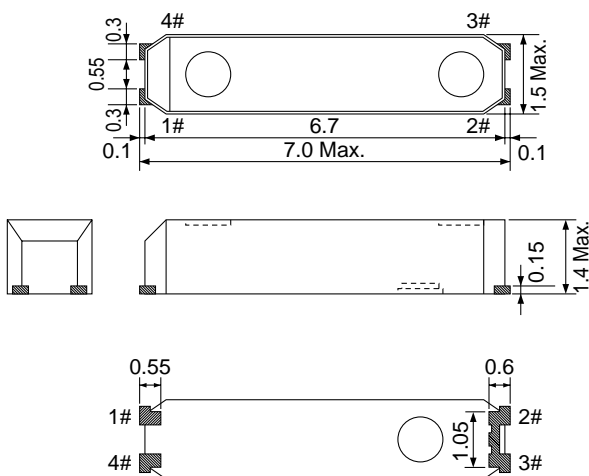

INTERNAL LEAD CONNECTION

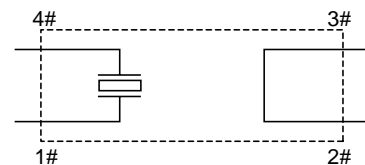

RECOMMENDED SOLDERING PATTERN

UNIT: mm

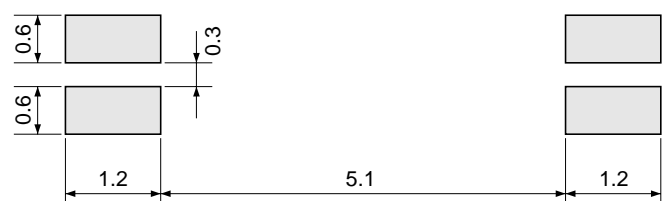

Remarks 1. Do not connect #2 and #3 to external device and GND.

2. The part of the cylinder inside resin mold may be sometimes exposed, however, it does not affect the characteristics of crystal unit.