

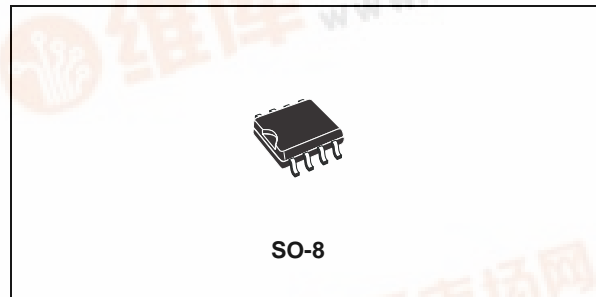

ST890

1.2A CURRENT LIMITED HIGH SIDE WITH THERMAL SHUTDOWN

- 2.7V TO 5.5V INPUT RANGE
- PROGRAMMABLE CURRENT LIMIT UP TO 1.2A
- LOW QUIESCENT CURRENT
- THERMAL SHUTDOWN
- FAULT INDICATOR OUTPUT
- 90mΩ (TYP.) ON RESISTANCE
- SO-8 PACKAGE



DESCRIPTION

The ST890 is a low voltage, P-Channel MOSFET power switch intended for high side load switching applications.

This switch operates with inputs from 2.7V to 5.5V, making it ideal for both 3V and 5V systems. Internal current limiting circuitry protects the input supply against overload. Thermal overload

protection limits power dissipation and junction temperatures.

The ST890's maximum current limit is 1.2A. The current limit through the switch is programmed with a resistor from SET to ground. The ST890 is available in SO-8 package. Main applications are: PCMCIA slots, Access bus slots, Portable equipment.

ORDERING CODES

Type	Temperature Range	Package	Comments
ST890CD	0 to 70 °C	SO-8 (Tube)	50parts per tube / 40tube per box
ST890CDR	0 to 70 °C	SO-8 (Tape & Reel)	2500 parts per reel
ST890BD	-40 to 85 °C	SO-8 (Tube)	50parts per tube / 40tube per box
ST890BDR	-40 to 85 °C	SO-8 (Tape & Reel)	2500 parts per reel

SCHEMATIC DIAGRAM

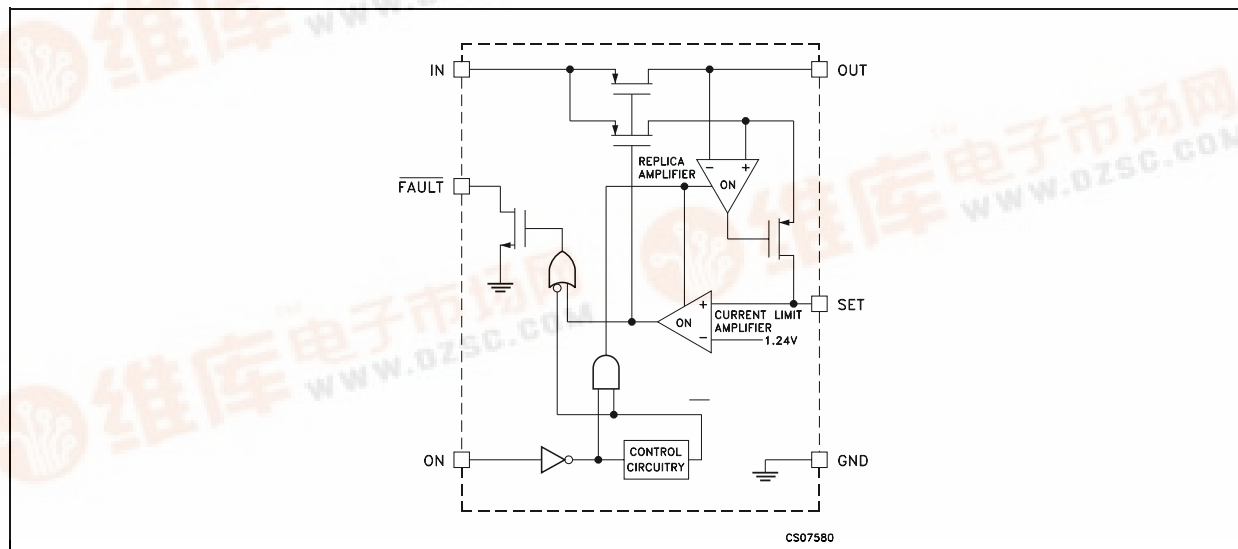

ST890

ABSOLUTE MAXIMUM RATINGS

Symbol	Parameter ²	Value	Unit
V_I	Supply Voltage	-0.5 to 6	V
V_{ON}, V_{FAULT}	Power DMOS Drain to Source Voltage	-0.5 to 6	V
V_{SET}, V_O	Logic Input Voltage	-0.5 to ($V_{IN} + 0.5$)	V
I_{DS}	Maximum Continuous Switching Current	1.5	A
T_{stg}	Storage Temperature Range	-65 to +150	°C
T_{op}	Operating Junction Temperature Range (C series) (B series)	0 to +70 -40 to +85	°C °C

Absolute Maximum Ratings are those values beyond which damage to the device may occur. Functional operation under these condition is not implied.

THERMAL DATA

Symbol	Parameter	SO-8	Unit
$R_{thj-amb}$	Thermal Resistance Junction-ambient (*)	160	°C/W

(*) This value depends from thermal design of PCB on which the device is mounted.

TRUTH TABLE FOR ON/OFF SWITCH

$\overline{ON/OFF}$	OUT
L	ON
H	OFF

FAULT	FLAG
H	Normal Operation
L	Fault Condition

CONNECTION DIAGRAM (top view)

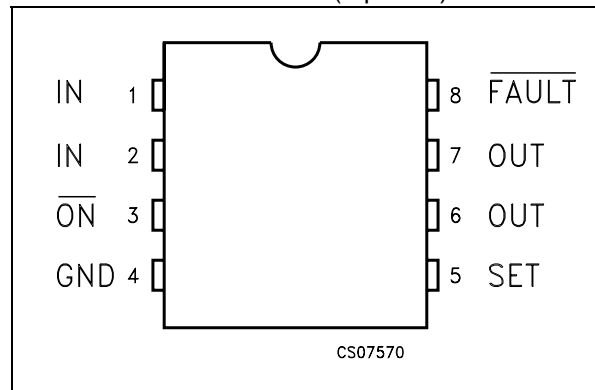

PIN DESCRIPTION

Pin N°	Symbol	Name and Function
1, 2	IN	Input P-Channel MOSFET source. Bypass IN with a 1 μ F capacitor to ground.
3	\overline{ON}	Active Low Switch On Input. A logic low turns the switch ON
4	GND	Ground
5	SET	Set Current Limit Input. A resistor from SET to GROUND sets the current limit for the switch. $R_{SET} = 1.38 \times 10^3 / I_{LIM}$, where I_{LIM} is the desired current limit in Amperes
6, 7	OUT	Switch Output. P-Channel MOSFET drain. Bypass OUT with a 0.1mF capacitor to GROUND.
8	\overline{FAULT}	Fault Indicator Output. This open drain output goes low when in current limit or when the die temperature exceeds 135°C

ELECTRICAL CHARACTERISTICS ($V_{IN}=3V$, $T_A = T_{MIN}$ to T_{MAX} , unless otherwise specified. Typical values are at $T_A = 25\text{ }^{\circ}\text{C}$)

Symbol	Parameter	Test Conditions	Min.	Typ.	Max.	Unit
V_I	Operating Voltage	$I_O = 1\text{mA}$	2.7		5.5	V
I_{CC}	ON Quiescent Supply Current	$V_I = 5V$, ON=GND $I_O = 0$		13	25	μA
$I_{I(CCOFF)}$	OFF Quiescent Supply Current	ON=IN $V_I = V_{OUT} = 5.5V$			1	μA
		ON=IN $V_I = 5.5V$ $V_O = 0$			5	
V_{ULO}	Undervoltage Lockout	Rising Edge	2.0	2.4	2.6	V
V_{HYST}	Undervoltage Lockout Hysteresys			100		mV
R_{ON}	ON Resistance	$V_I = 4.5V$		75	120	m Ω
		$V_I = 3V$		90	130	
V_{SET}	Reference Voltage to Turns The Switch OFF	$I_O = 100\text{mA}$ V_{SET} rised until $V_I - V_O > 0.8V$	1.178	1.24	1.302	V
I_{MAX}	Maximum Output Current Limit			1.2		A
I_{SC}	Short Circuit Current Limit			$1.2 I_{LIM}$		A
I_O/I_{SET}	I_O to I_{SET} Current Ratio	$I_O = 500\text{mA}$ $V_O > 1.6V$	970	1110	1300	
V_{IL}	ON Input Low Level Voltage	$V_I = 2.7$ to $5.5V$			0.8	V
V_{IH}	ON Input High Level Voltage	$V_I = 2.7$ to $3.6V$	2.0			V
		$V_I = 4.5$ to $5.5V$	2.4			
I_I	ON Input Leakage Current	$V_I = 5.5V$			1	μA
I_{SET}	I_{SET} Bias Current	$V_{SET} = 1.24V$ $I_O = 0A$ $V_I = V_O$		0.5	3	μA
V_{OL}	FAULT Output Low Voltage	$I_{SINK} = 1\text{mA}$ $V_{SET} = 1.4V$		0.15		V
I_{OH}	FAULT Output High Voltage	$V_{FAULT} = 5.5V$ $V_{SET} = 1V$			1	μA
T_{PROT}	Thermal Protection			130		$^{\circ}\text{C}$
T_{HYST}	Thermal Hysteresys			15		$^{\circ}\text{C}$

TIMING CHARACTERISTICS ($V_{IN}=3V$, $T_A = T_{MIN}$ to T_{MAX} , unless otherwise specified. Typical values are at $T_A = 25\text{ }^{\circ}\text{C}$)

Symbol	Parameter	Test Conditions	Min.	Typ.	Max.	Unit
t_{RESP}	Slow Current Loop Response Time	20% Current Overdrive, $V_{CC} = 5V$		5		μs
	Fast Current Loop Response Time			2		μs
t_{ON}	Turn ON Time	$V_I = 5V$, $I_O = 500\text{mA}$		25	50	μs
		$V_I = 3V$, $I_O = 500\text{mA}$		50		
t_{OFF}	Turn OFF Time	$V_I = 5V$	1	2	10	μs

TYPICAL APPLICATION CIRCUIT

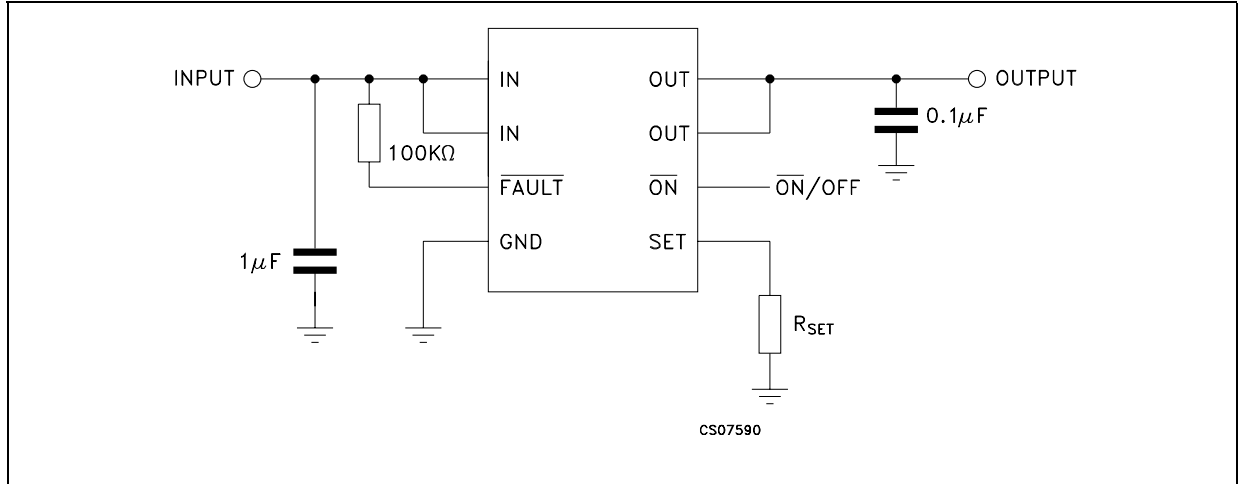

TYPICAL PERFORMANCE CHARACTERISTICS (unless otherwise specified $T_j = 25^\circ\text{C}$)

Figure 1 : ON Resistance vs Supply Voltage

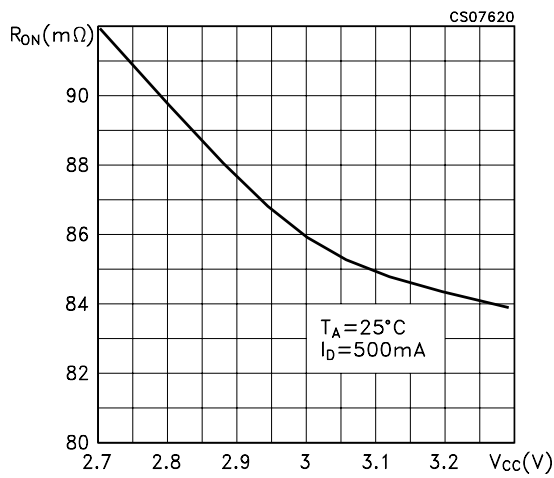

Figure 2 : ON Resistance vs Supply Voltage

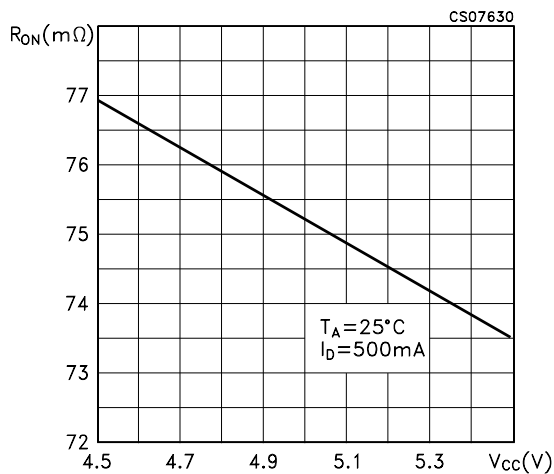

Figure 3 : ON Resistance vs Temperature

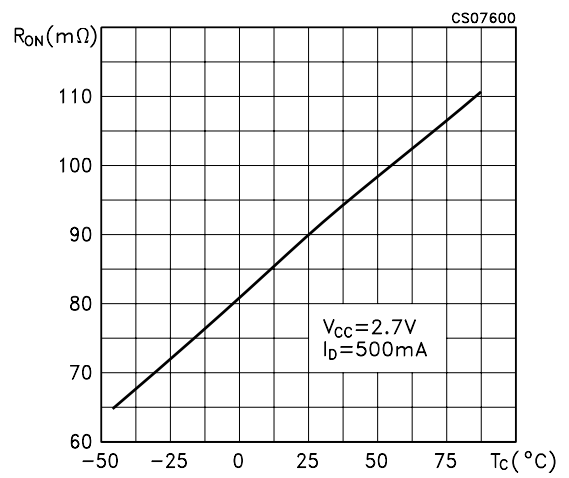

Figure 4 : Output Voltage vs Input Voltage

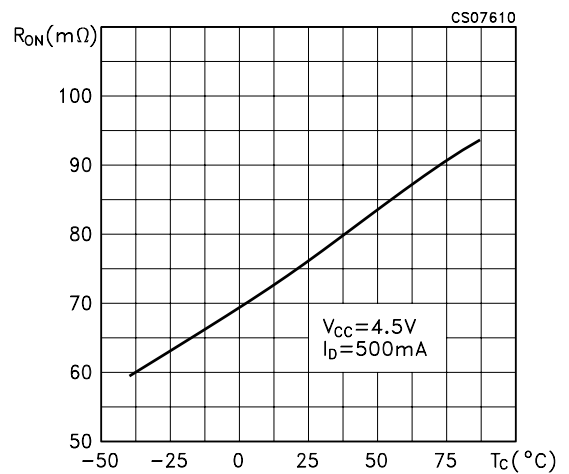

Figure 5 : Switching Waveforms,

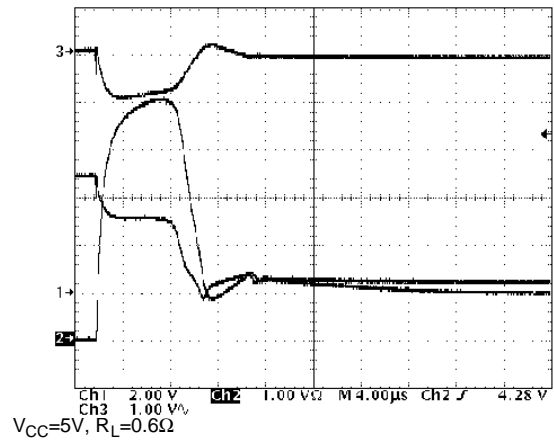
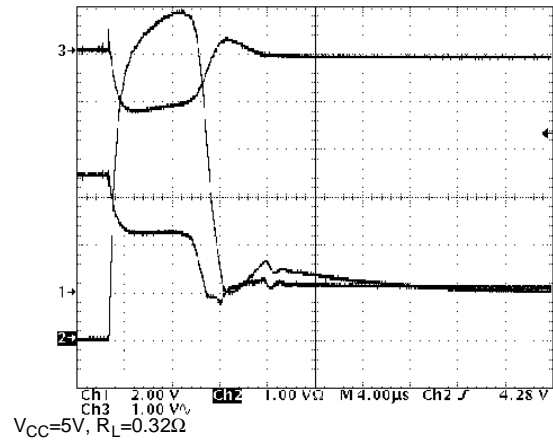
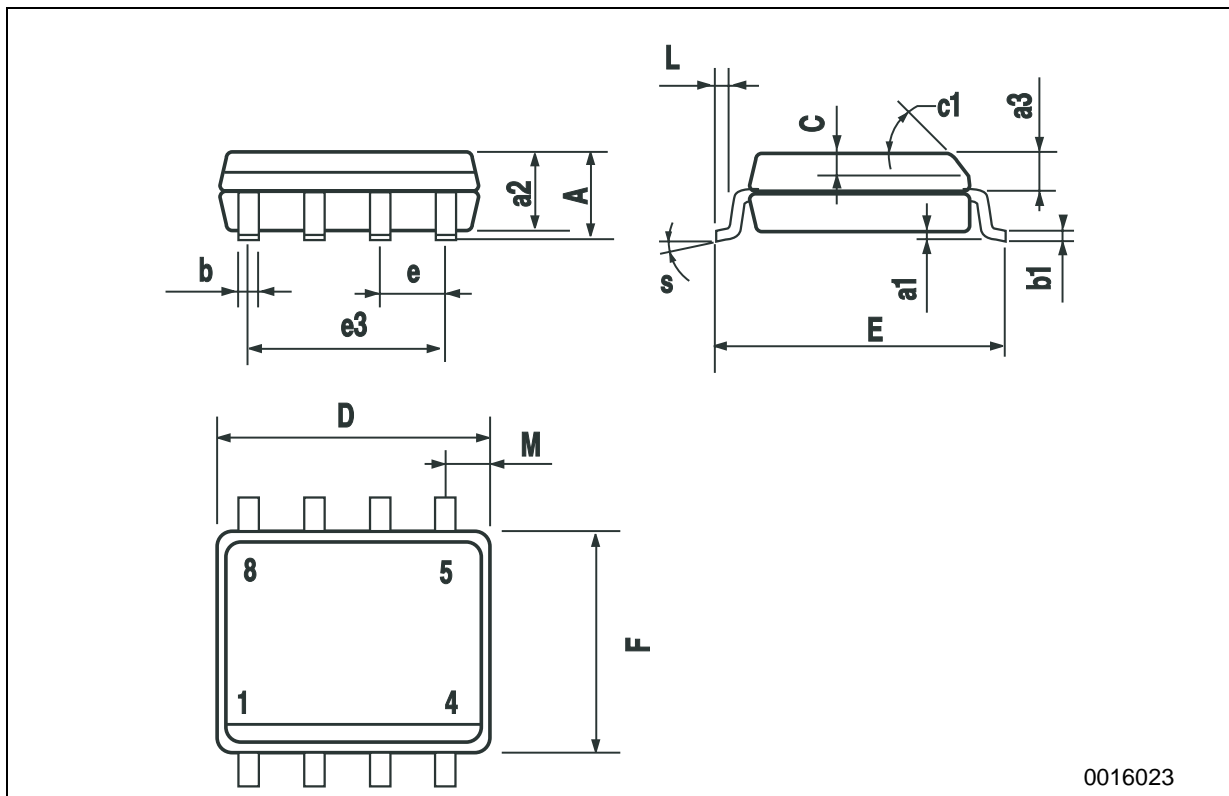

Figure 6 : Switching Waveforms,



SO-8 MECHANICAL DATA

DIM.	mm.			inch		
	MIN.	TYP	MAX.	MIN.	TYP.	MAX.
A			1.75			0.068
a1	0.1		0.25	0.003		0.009
a2			1.65			0.064
a3	0.65		0.85	0.025		0.033
b	0.35		0.48	0.013		0.018
b1	0.19		0.25	0.007		0.010
C	0.25		0.5	0.010		0.019
c1	45° (typ.)					
D	4.8		5.0	0.189		0.196
E	5.8		6.2	0.228		0.244
e		1.27			0.050	
e3		3.81			0.150	
F	3.8		4.0	0.149		0.157
L	0.4		1.27	0.015		0.050
M			0.6			0.023
S	8° (max.)					



0016023

Information furnished is believed to be accurate and reliable. However, STMicroelectronics assumes no responsibility for the consequences of use of such information nor for any infringement of patents or other rights of third parties which may result from its use. No license is granted by implication or otherwise under any patent or patent rights of STMicroelectronics. Specifications mentioned in this publication are subject to change without notice. This publication supersedes and replaces all information previously supplied. STMicroelectronics products are not authorized for use as critical components in life support devices or systems without express written approval of STMicroelectronics.

© The ST logo is a registered trademark of STMicroelectronics

© 2002 STMicroelectronics - Printed in Italy - All Rights Reserved
STMicroelectronics GROUP OF COMPANIES

Australia - Brazil - Canada - China - Finland - France - Germany - Hong Kong - India - Israel - Italy - Japan - Malaysia - Malta - Morocco
Singapore - Spain - Sweden - Switzerland - United Kingdom - United States.

© <http://www.st.com>