



**STP12NM50FD-STP12NM50FD-1P-STW14NM50FD**

**STB12NM50FD - STB12NM50FD-1**

**N-CHANNEL 500V-0.32Ω-12A TO-220/FP/D<sup>2</sup>PAK/I<sup>2</sup>PAK/TO-247  
FDmesh™ Power MOSFET (with FAST DIODE)**

TYPE	V <sub>DSS</sub>	R <sub>DS(on)</sub>	I <sub>D</sub>	P <sub>w</sub>
STP12NM50FD	500 V	< 0.4 Ω	12 A	160 W
STP12NM50FD-1P	500 V	< 0.4 Ω	12 A	35 W
STB12NM50FD	500 V	< 0.4 Ω	12 A	160 W
STB12NM50FD-1	500 V	< 0.4 Ω	12 A	160 W
STW14NM50FD	500 V	< 0.4 Ω	14 A	175 W

- TYPICAL R<sub>DS(on)</sub> = 0.32 Ω
- HIGH dv/dt AND AVALANCHE CAPABILITIES
- 100% AVALANCHE TESTED
- LOW INPUT CAPACITANCE AND GATE CHARGE
- LOW GATE INPUT RESISTANCE
- TIGHT PROCESS CONTROL AND HIGH MANUFACTURING YIELDS

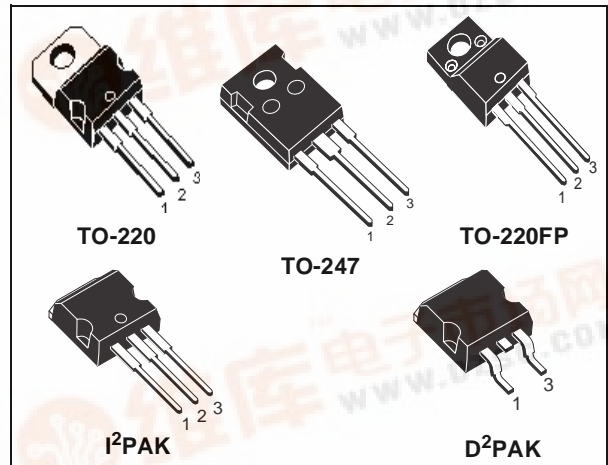

**DESCRIPTION**

The FDmesh™ associates all advantages of reduced on-resistance and fast switching with an intrinsic fast-recovery body diode. It is therefore strongly recommended for bridge topologies, in particular ZVS phase-shift converters.

**APPLICATIONS**

- ZVS PHASE-SHIFT FULL BRIDGE CONVERTERS FOR SMPS AND WELDING EQUIPMENT

**INTERNAL SCHEMATIC DIAGRAM**

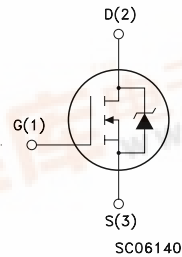

**ORDERING INFORMATION**

SALES TYPE	MARKING	PACKAGE	PACKAGING
STP12NM50FD	P12NM50FD	TO-220	TUBE
STP12NM50FD-1P	P12NM50FD-1P	TO-220FP	TUBE
STB12NM50FD	B12NM50FD	D <sup>2</sup> PAK	TUBE
STB12NM50FD-1	B12NM50FD	D <sup>2</sup> PAK	TAPE & REEL
STB12NM50FD-1P	B12NM50FD	I <sup>2</sup> PAK	TUBE
STW14NM50FD	W14NM50FD	TO-247	TUBE

**STP12NM50FD / STP12NM50FDFP / STB12NM50FD / STB12NM50FD-1 / STW14NM50FD**

**ABSOLUTE MAXIMUM RATINGS**

Symbol	Parameter	Value			Unit
		TO-220 / D <sup>2</sup> PAK / I <sup>2</sup> PAK	TO-220FP	TO-247	
V <sub>DS</sub>	Drain-source Voltage (V <sub>GS</sub> = 0)	500			V
V <sub>DGR</sub>	Drain-gate Voltage (R <sub>GS</sub> = 20 kΩ)	500			V
V <sub>GS</sub>	Gate- source Voltage	± 30			V
I <sub>D</sub>	Drain Current (continuous) at T <sub>C</sub> = 25°C	12	12 (*)	14	A
I <sub>D</sub>	Drain Current (continuous) at T <sub>C</sub> = 100°C	7.5	7.5 (*)	8.8	A
I <sub>DM</sub> (•)	Drain Current (pulsed)	48	48 (*)	56	A
P <sub>TOT</sub>	Total Dissipation at T <sub>C</sub> = 25°C	160	35	175	W
	Derating Factor	1.28	0.28	1.4	W/°C
dv/dt (1)	Peak Diode Recovery voltage slope	20			V/ns
V <sub>ISO</sub>	Insulation Withstand Voltage (DC)	-	2500		V
T <sub>j</sub> T <sub>stg</sub>	Operating Junction Temperature Storage Temperature	- 65 to 150			°C °C

(•) Pulse width limited by safe operating area  
 (1) I<sub>SD</sub> ≤ 12A, di/dt ≤ 400 μA, V<sub>DD</sub> ≤ V<sub>(BR)DSS</sub>, T<sub>j</sub> ≤ T<sub>JMAX</sub>.  
 (\*) Limited only by maximum temperature allowed

**THERMAL DATA**

		TO-220 / I <sup>2</sup> PAK	D <sup>2</sup> PAK	TO-220FP	TO-247	
R <sub>thj-case</sub>	Thermal Resistance Junction-case Max	0.78		3.57	0.715	°C/W
R <sub>thj-pcb</sub>	Thermal Resistance Junction-pcb Max (When mounted on minimum Footprint)		30			°C/W
R <sub>thj-amb</sub>	Thermal Resistance Junction-ambient Max	62.5			30	°C/W
T <sub>I</sub>	Maximum Lead Temperature For Soldering Purpose	300				°C

**AVALANCHE CHARACTERISTICS**

Symbol	Parameter	Max Value	Unit
I <sub>AR</sub>	Avalanche Current, Repetitive or Not-Repetitive (pulse width limited by T <sub>j</sub> max)	6	A
E <sub>AS</sub>	Single Pulse Avalanche Energy (starting T <sub>j</sub> = 25 °C, I <sub>D</sub> = I <sub>AR</sub> , V <sub>DD</sub> = 50 V)	400	mJ

**STP12NM50FD / STP12NM50FDFP / STB12NM50FD / STB12NM50FD-1 / STW14NM50FD**

**ELECTRICAL CHARACTERISTICS (TCASE =25°C UNLESS OTHERWISE SPECIFIED)  
ON/OFF**

Symbol	Parameter	Test Conditions	Min.	Typ.	Max.	Unit
V <sub>(BR)DSS</sub>	Drain-source Breakdown Voltage	I <sub>D</sub> = 1 mA, V <sub>GS</sub> = 0	500			V
I <sub>DSS</sub>	Zero Gate Voltage Drain Current (V <sub>GS</sub> = 0)	V <sub>DS</sub> = Max Rating V <sub>DS</sub> = Max Rating, T <sub>C</sub> = 125 °C			1 10	μA μA
I <sub>GSS</sub>	Gate-body Leakage Current (V <sub>DS</sub> = 0)	V <sub>GS</sub> = ± 30V			±100	nA
V <sub>GS(th)</sub>	Gate Threshold Voltage	V <sub>DS</sub> = V <sub>GS</sub> , I <sub>D</sub> = 250μA	3	4	5	V
R <sub>DS(on)</sub>	Static Drain-source On Resistance	V <sub>GS</sub> = 10V, I <sub>D</sub> = 6A		0.32	0.4	Ω

**DYNAMIC**

Symbol	Parameter	Test Conditions	Min.	Typ.	Max.	Unit
g <sub>fs</sub> (1)	Forward Transconductance	V <sub>DS</sub> = 15 V, I <sub>D</sub> = 6 A		9.8		S
C <sub>iss</sub> C <sub>oss</sub> C <sub>rss</sub>	Input Capacitance Output Capacitance Reverse Transfer Capacitance	V <sub>DS</sub> = 25V, f = 1 MHz, V <sub>GS</sub> = 0		1027 205 24		pF pF pF
R <sub>G</sub>	Gate Input Resistance	f=1 MHz Gate DC Bias = 0 Test Signal Level = 20mV Open Drain		3.7		Ω

**SWITCHING ON**

Symbol	Parameter	Test Conditions	Min.	Typ.	Max.	Unit
t <sub>d(on)</sub> t <sub>r</sub>	Turn-on Delay Time Rise Time	V <sub>DD</sub> = 250 V, I <sub>D</sub> = 6 A R <sub>G</sub> = 4.7Ω, V <sub>GS</sub> = 10 V (Resistive Load see, Figure 3)		19 10		ns ns
Q <sub>g</sub> Q <sub>gs</sub> Q <sub>gd</sub>	Total Gate Charge Gate-Source Charge Gate-Drain Charge	V <sub>DD</sub> = 400V, I <sub>D</sub> = 12 A, V <sub>GS</sub> = 10V		27.5 8 12	38.5	nC nC nC

**SWITCHING OFF**

Symbol	Parameter	Test Conditions	Min.	Typ.	Max.	Unit
t <sub>r(Voff)</sub> t <sub>f</sub> t <sub>c</sub>	Off-voltage Rise Time Fall Time Cross-over Time	V <sub>DD</sub> = 400 V, I <sub>D</sub> = 12 A, R <sub>G</sub> = 4.7Ω, V <sub>GS</sub> = 10V (Inductive Load see, Figure 5)		39 18 29		ns ns ns

**SOURCE DRAIN DIODE**

Symbol	Parameter	Test Conditions	Min.	Typ.	Max.	Unit
I <sub>SD</sub> I <sub>SDM</sub> (2)	Source-drain Current Source-drain Current (pulsed)				12 48	A A
V <sub>SD</sub> (1)	Forward On Voltage	I <sub>SD</sub> = 12 A, V <sub>GS</sub> = 0			1.5	V
t <sub>rr</sub> Q <sub>rr</sub> I <sub>RRM</sub>	Reverse Recovery Time Reverse Recovery Charge Reverse Recovery Current	I <sub>SD</sub> = 12 A, di/dt = 100A/μs V <sub>DD</sub> = 30V, T <sub>j</sub> = 150°C (see test circuit, Figure 5)		224 1.3 12		ns μC A

Note: 1. Pulsed: Pulse duration = 300 μs, duty cycle 1.5 %.  
2. Pulse width limited by safe operating area.

**STP12NM50FD / STP12NM50FDFP / STB12NM50FD / STB12NM50FD-1 / STW14NM50FD**

**Safe Operating Area For TO-220/D2PAK/I2PAK**

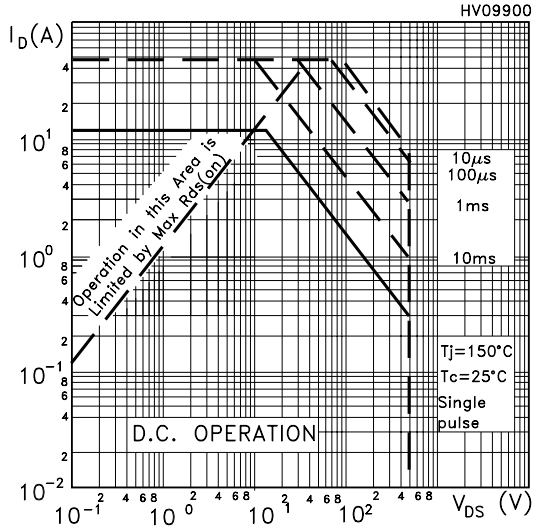

**Thermal Impedance For TO-220/D2PAK/I2PAK**

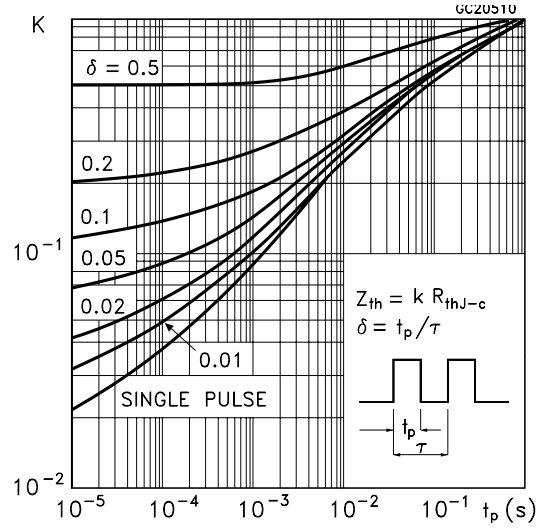

**Safe Operating Area For TO-220FP**

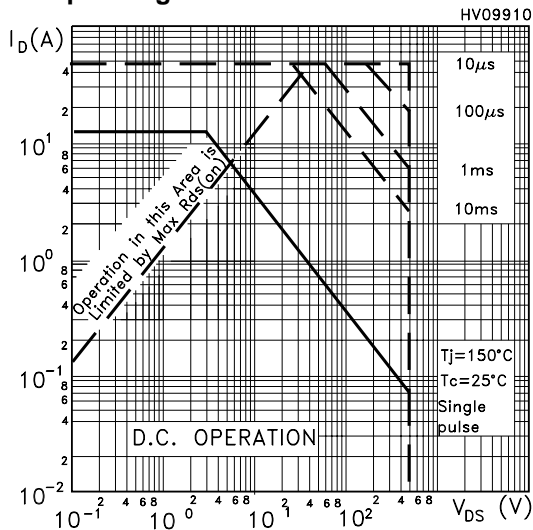

**Thermal Impedance For TO-220FP**

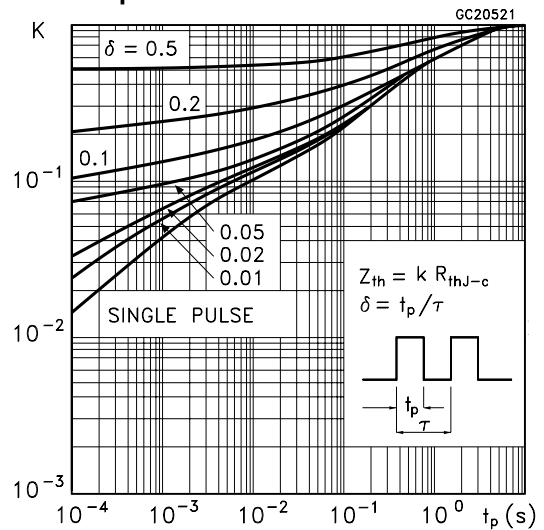

**Safe Operating Area For TO-247**

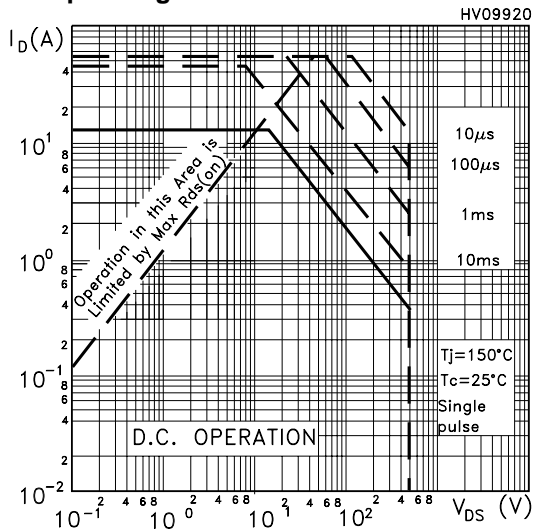

**Thermal Impedance For TO-247**

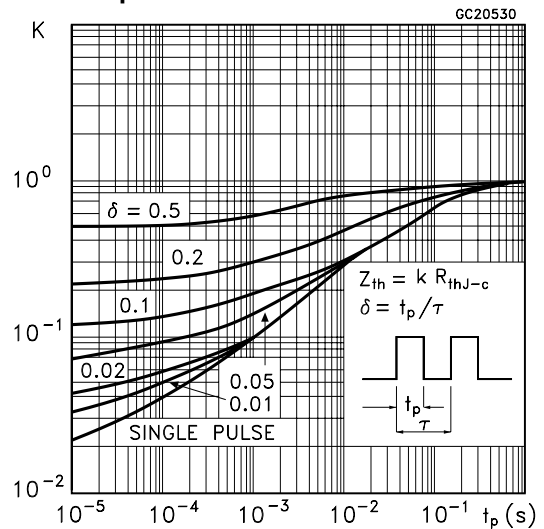

**STP12NM50FD / STP12NM50FDFP / STB12NM50FD / STB12NM50FD-1 / STW14NM50FD**

**Output Characteristics**

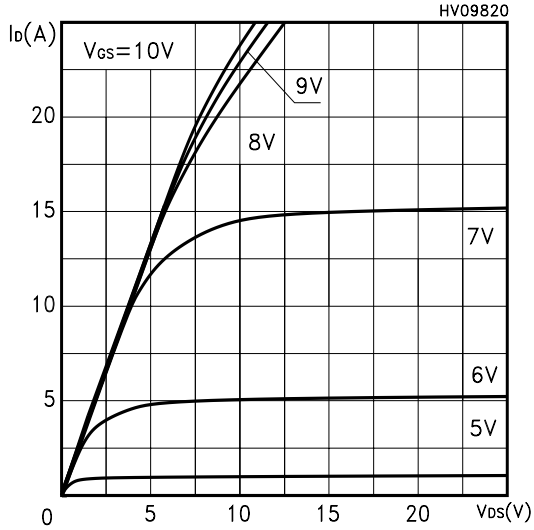

**Transfer Characteristics**

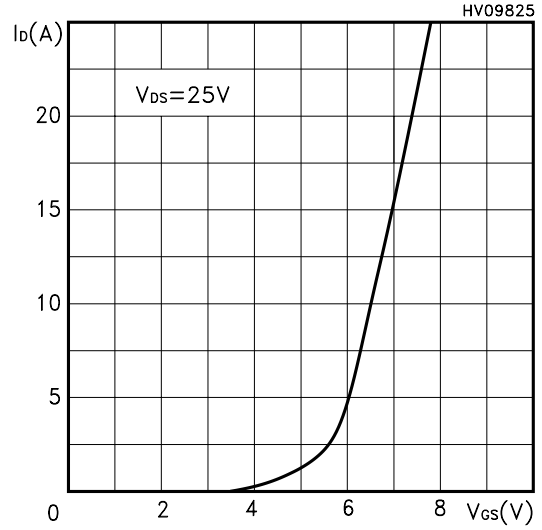

**Transconductance**

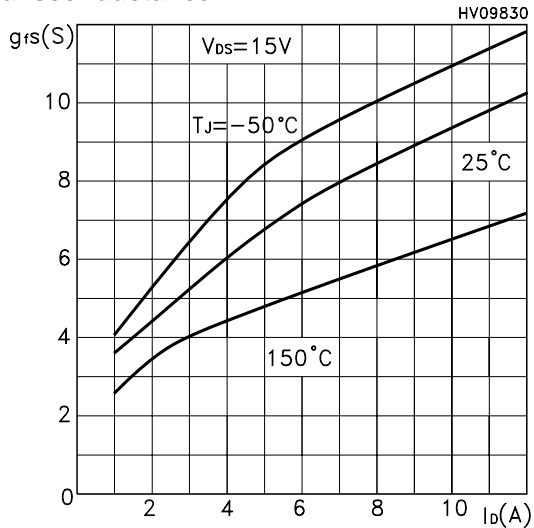

**Static Drain-source On Resistance**

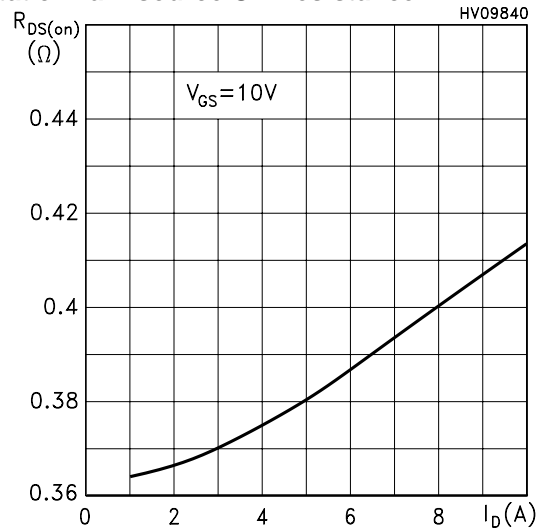

**Gate Charge vs Gate-source Voltage**

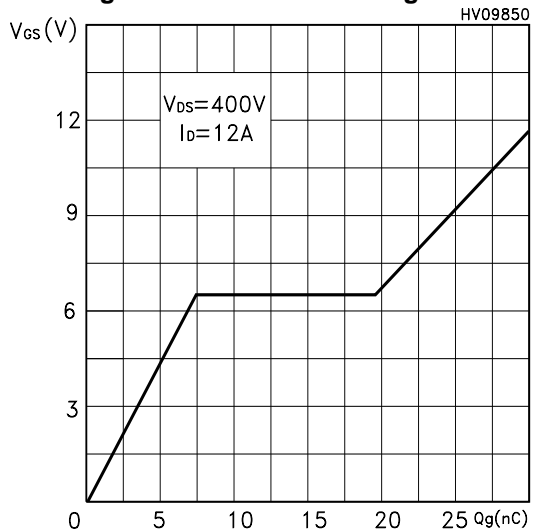

**Capacitance Variations**

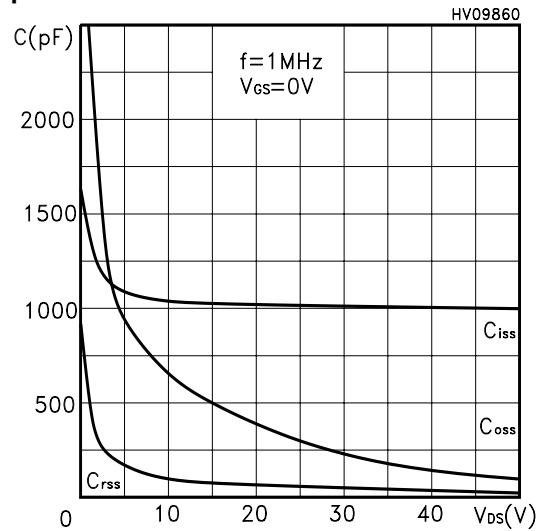

**STP12NM50FD / STP12NM50FDFP / STB12NM50FD / STB12NM50FD-1 / STW14NM50FD**

**Normalized Gate Threshold Voltage vs Temp.**

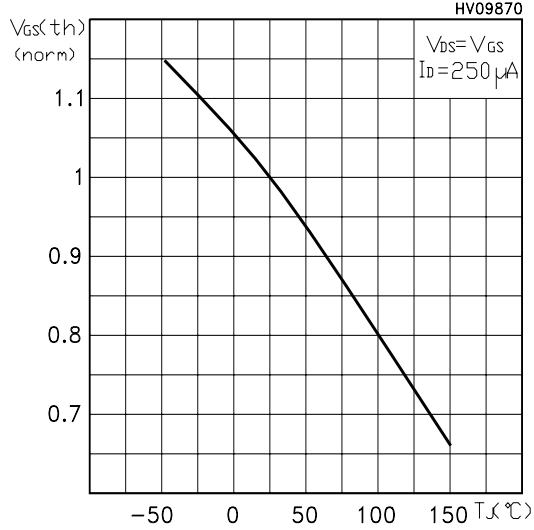

**Normalized On Resistance vs Temperature**

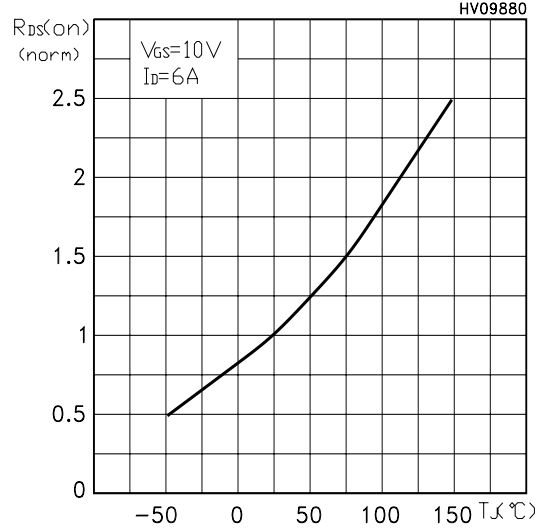

**Source-drain Diode Forward Characteristics**

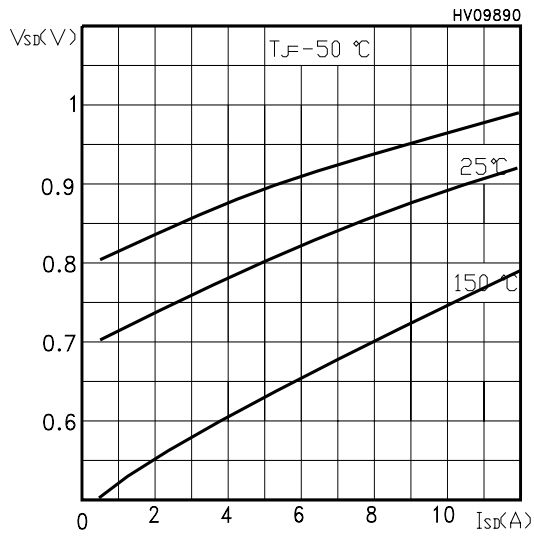

**Normalized BVDS vs Temperature**

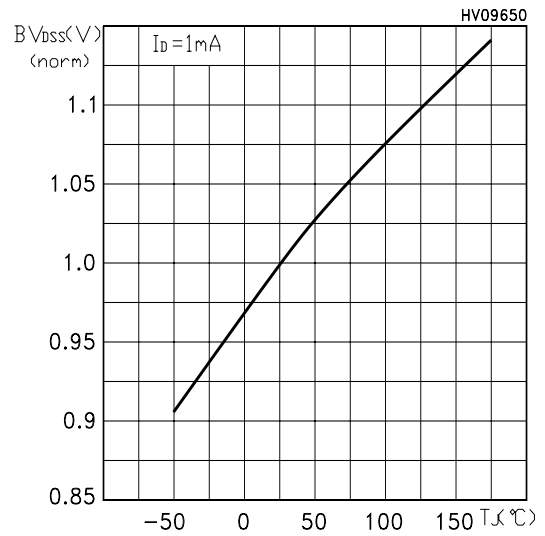

**STP12NM50FD / STP12NM50FDFP / STB12NM50FD / STB12NM50FD-1 / STW14NM50FD**

**Fig. 1: Unclamped Inductive Load Test Circuit**

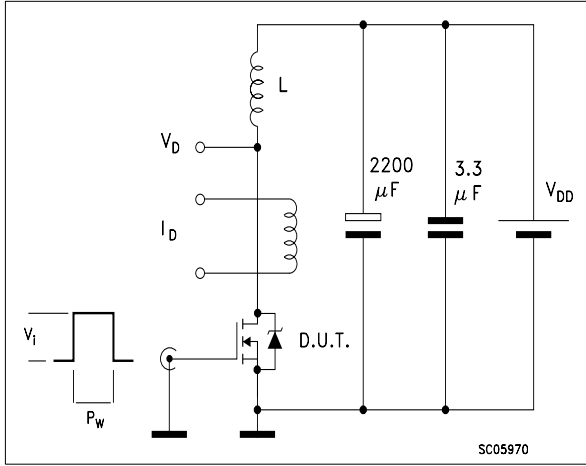

**Fig. 2: Unclamped Inductive Waveform**

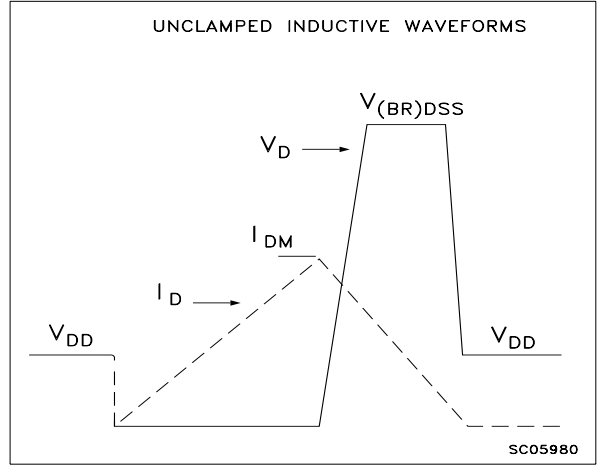

**Fig. 3: Switching Times Test Circuit For Resistive Load**

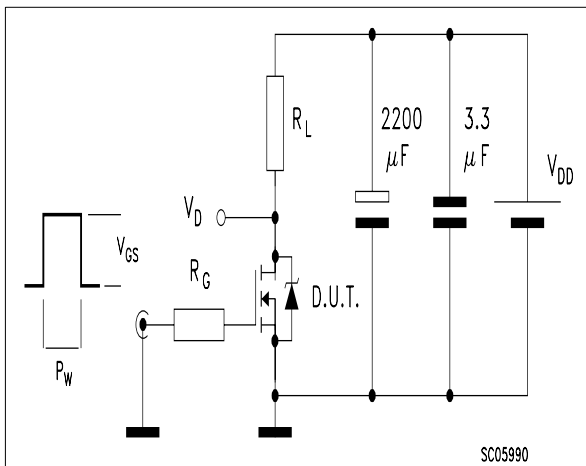

**Fig. 4: Gate Charge test Circuit**

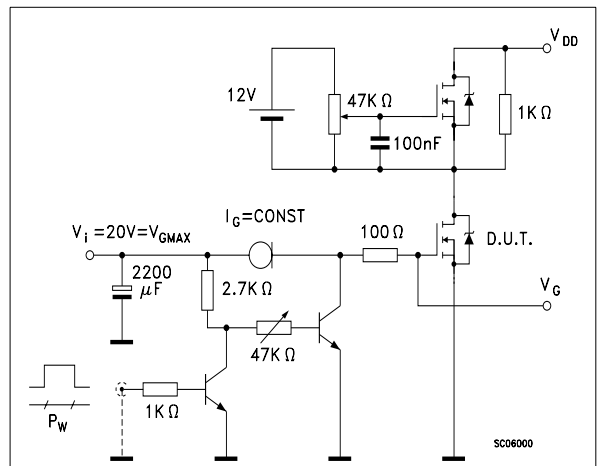

**Fig. 5: Test Circuit For Inductive Load Switching And Diode Recovery Times**

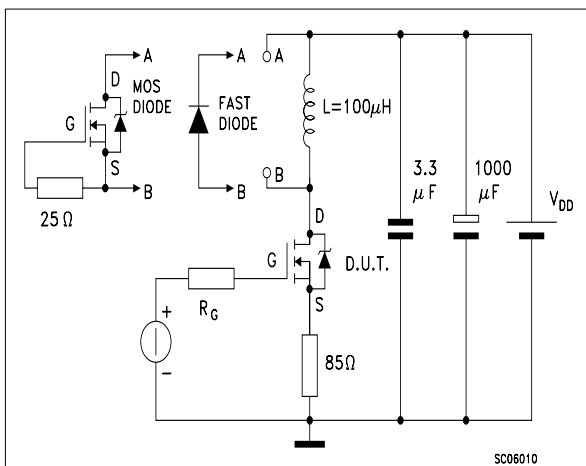

**STP12NM50FD / STP12NM50FDFP / STB12NM50FD / STB12NM50FD-1 / STW14NM50FD**

**TO-220 MECHANICAL DATA**

DIM.	mm			inch		
	MIN.	TYP.	MAX.	MIN.	TYP.	MAX.
A	4.40		4.60	0.173		0.181
C	1.23		1.32	0.048		0.051
D	2.40		2.72	0.094		0.107
D1		1.27			0.050	
E	0.49		0.70	0.019		0.027
F	0.61		0.88	0.024		0.034
F1	1.14		1.70	0.044		0.067
F2	1.14		1.70	0.044		0.067
G	4.95		5.15	0.194		0.203
G1	2.4		2.7	0.094		0.106
H2	10.0		10.40	0.393		0.409
L2		16.4			0.645	
L4	13.0		14.0	0.511		0.551
L5	2.65		2.95	0.104		0.116
L6	15.25		15.75	0.600		0.620
L7	6.2		6.6	0.244		0.260
L9	3.5		3.93	0.137		0.154
DIA.	3.75		3.85	0.147		0.151

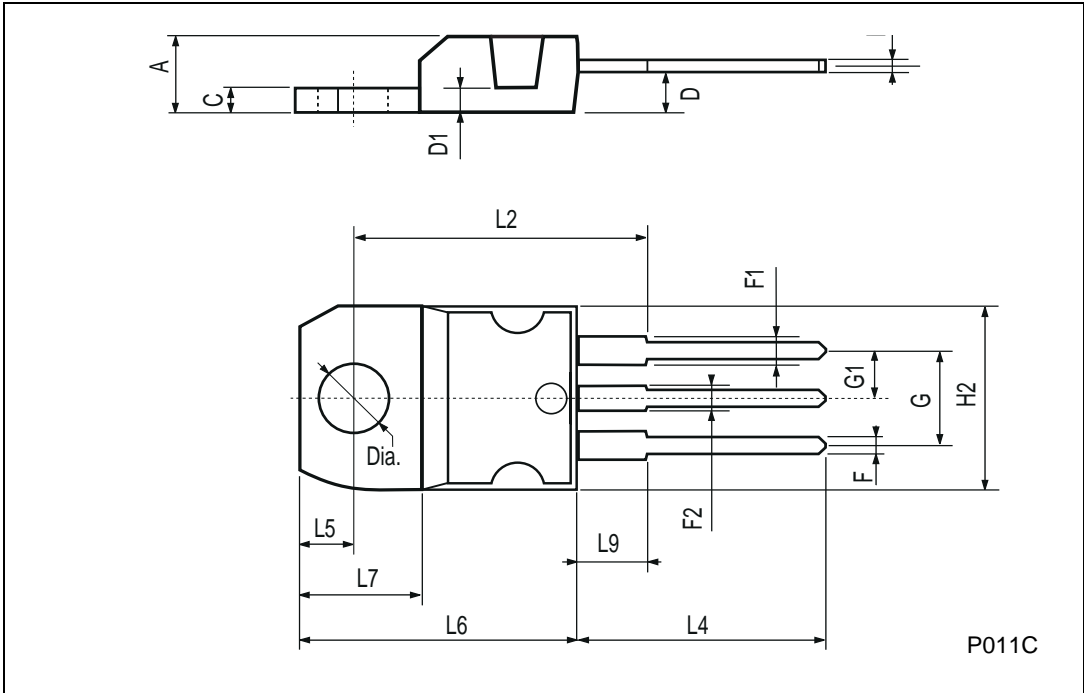



**TO-220FP MECHANICAL DATA**

DIM.	mm.			inch		
	MIN.	TYP	MAX.	MIN.	TYP.	MAX.
A	4.4		4.6	0.173		0.181
B	2.5		2.7	0.098		0.106
D	2.5		2.75	0.098		0.108
E	0.45		0.7	0.017		0.027
F	0.75		1	0.030		0.039
F1	1.15		1.7	0.045		0.067
F2	1.15		1.7	0.045		0.067
G	4.95		5.2	0.195		0.204
G1	2.4		2.7	0.094		0.106
H	10		10.4	0.393		0.409
L2		16			0.630	
L3	28.6		30.6	1.126		1.204
L4	9.8		10.6	.0385		0.417
L5	2.9		3.6	0.114		0.141
L6	15.9		16.4	0.626		0.645
L7	9		9.3	0.354		0.366
Ø	3		3.2	0.118		0.126

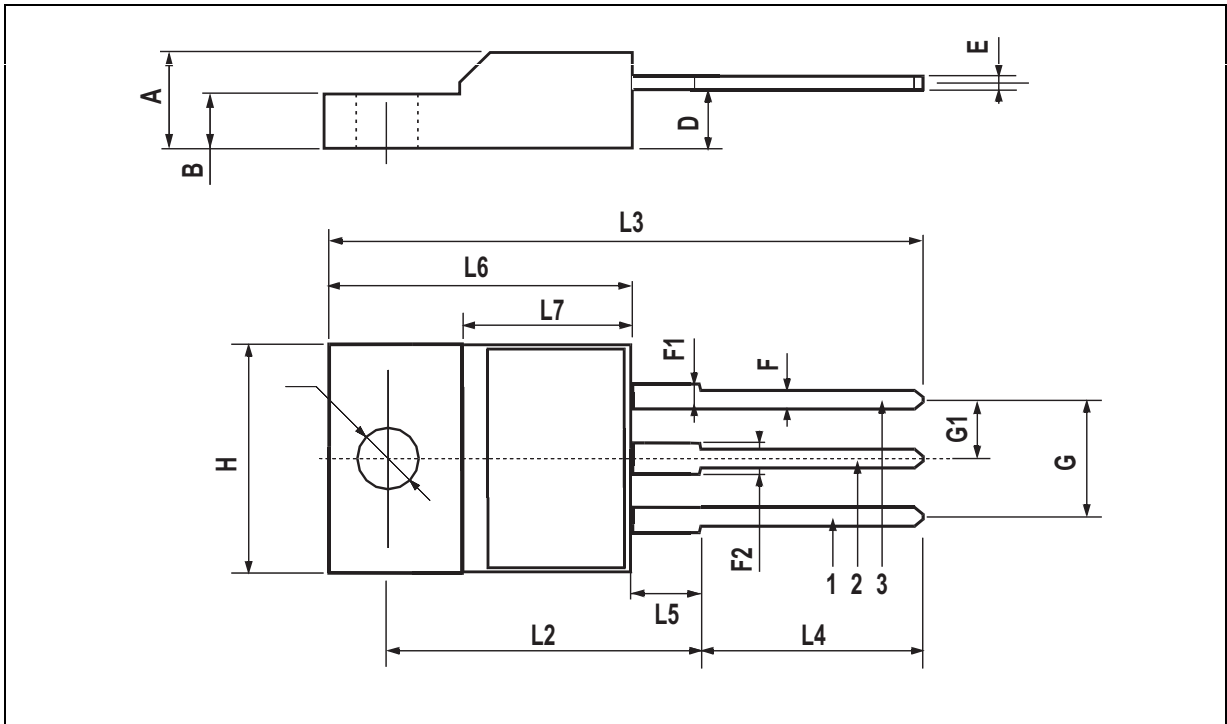

**STP12NM50FD / STP12NM50FDFP / STB12NM50FD / STB12NM50FD-1 / STW14NM50FD**

**D<sup>2</sup>PAK MECHANICAL DATA**

DIM.	mm.			inch		
	MIN.	TYP	MAX.	MIN.	TYP.	MAX.
A	4.4		4.6	0.173		0.181
A1	2.49		2.69	0.098		0.106
A2	0.03		0.23	0.001		0.009
B	0.7		0.93	0.027		0.036
B2	1.14		1.7	0.044		0.067
C	0.45		0.6	0.017		0.023
C2	1.23		1.36	0.048		0.053
D	8.95		9.35	0.352		0.368
D1		8			0.315	
E	10		10.4	0.393		
E1		8.5			0.334	
G	4.88		5.28	0.192		0.208
L	15		15.85	0.590		0.625
L2	1.27		1.4	0.050		0.055
L3	1.4		1.75	0.055		0.068
M	2.4		3.2	0.094		0.126
R		0.4			0.015	
V2	0°		8°			

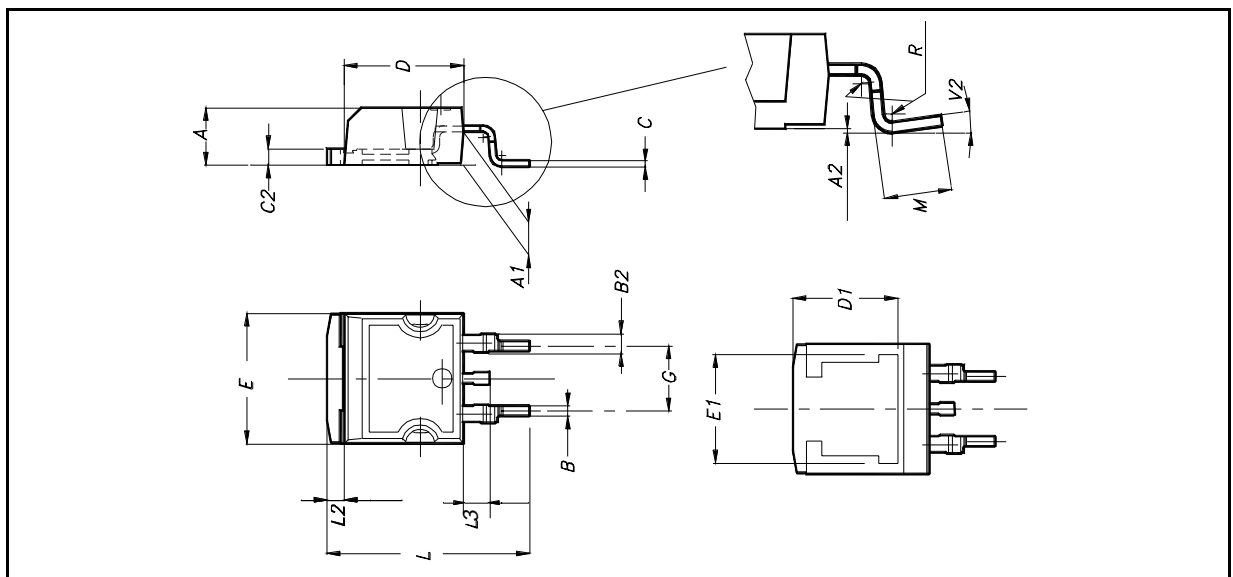

**STP12NM50FD / STP12NM50FDFP / STB12NM50FD / STB12NM50FD-1 / STW14NM50FD**

**TO-262 (I<sup>2</sup>PAK) MECHANICAL DATA**

DIM.	mm			inch		
	MIN.	TYP.	MAX.	MIN.	TYP.	MAX.
A	4.4		4.6	0.173		0.181
A1	2.49		2.69	0.098		0.106
B	0.7		0.93	0.027		0.036
B2	1.14		1.7	0.044		0.067
C	0.45		0.6	0.017		0.023
C2	1.23		1.36	0.048		0.053
D	8.95		9.35	0.352		0.368
e	2.4		2.7	0.094		0.106
E	10		10.4	0.393		0.409
L	13.1		13.6	0.515		0.531
L1	3.48		3.78	0.137		0.149
L2	1.27		1.4	0.050		0.055

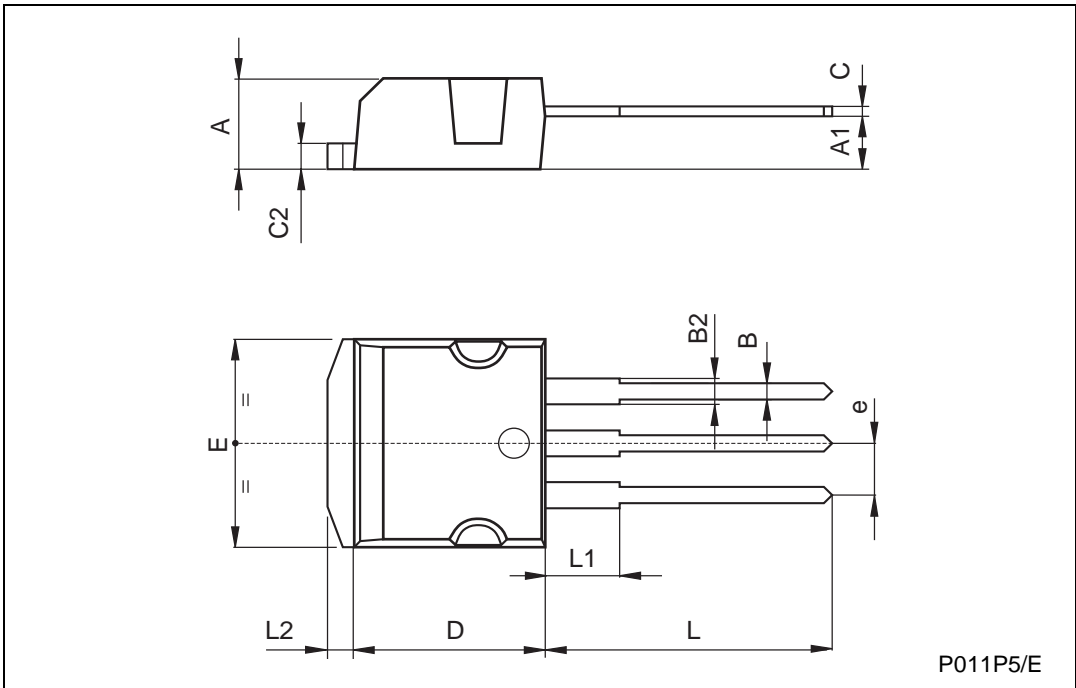

**STP12NM50FD / STP12NM50FDFP / STB12NM50FD / STB12NM50FD-1 / STW14NM50FD**

**TO-247 MECHANICAL DATA**

DIM.	mm			inch		
	MIN.	TYP.	MAX.	MIN.	TYP.	MAX.
A	4.7		5.3	0.185		0.209
D	2.2		2.6	0.087		0.102
E	0.4		0.8	0.016		0.031
F	1		1.4	0.039		0.055
F3	2		2.4	0.079		0.094
F4	3		3.4	0.118		0.134
G		10.9			0.429	
H	15.3		15.9	0.602		0.626
L	19.7		20.3	0.776		0.779
L3	14.2		14.8	0.559		0.582
L4		34.6			1.362	
L5		5.5			0.217	
M	2		3	0.079		0.118

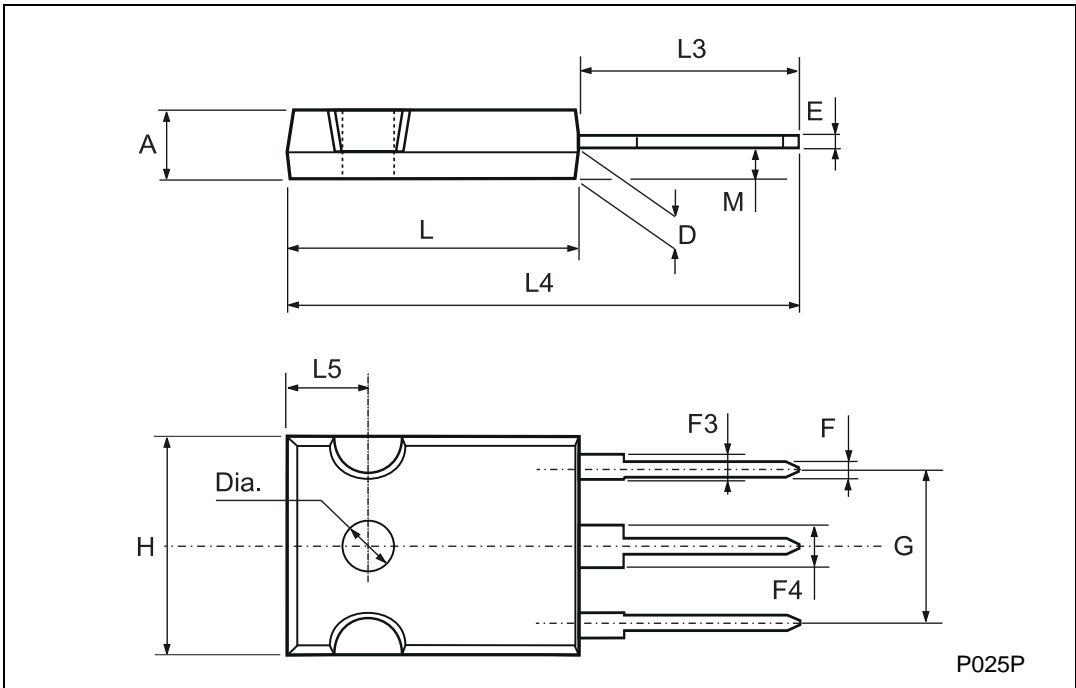

**D<sup>2</sup>PAK FOOTPRINT**

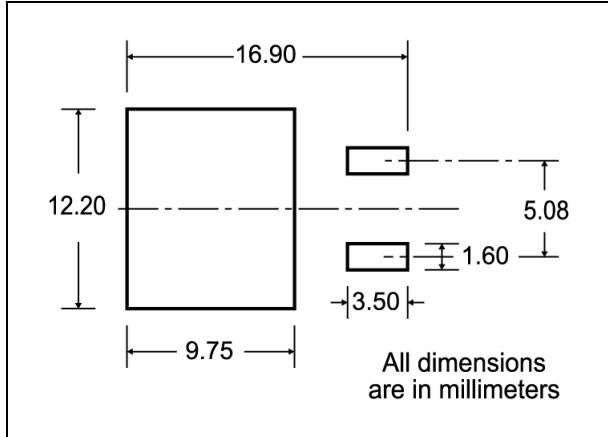

**TUBE SHIPMENT (no suffix)\***

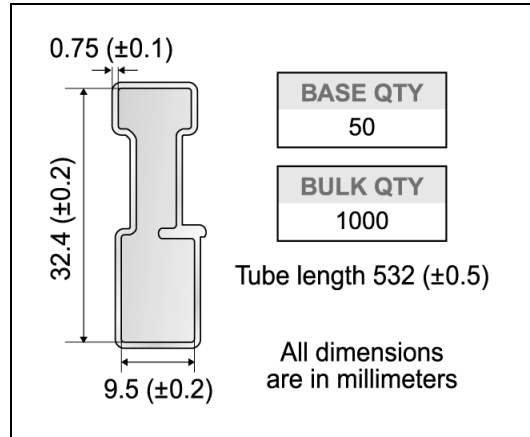

**TAPE AND REEL SHIPMENT (suffix "T4")\***

**TAPE MECHANICAL DATA**

DIM.	mm		inch	
	MIN.	MAX.	MIN.	MAX.
A0	10.5	10.7	0.413	0.421
B0	15.7	15.9	0.618	0.626
D	1.5	1.6	0.059	0.063
D1	1.59	1.61	0.062	0.063
E	1.65	1.85	0.065	0.073
F	11.4	11.6	0.449	0.456
K0	4.8	5.0	0.189	0.197
P0	3.9	4.1	0.153	0.161
P1	11.9	12.1	0.468	0.476
P2	1.9	2.1	0.075	0.082
R	50		1.574	
T	0.25	0.35	0.0098	0.0137
W	23.7	24.3	0.933	0.956

**REEL MECHANICAL DATA**

DIM.	mm		inch	
	MIN.	MAX.	MIN.	MAX.
A		330		12.992
B	1.5		0.059	
C	12.8	13.2	0.504	0.520
D	20.2		0.795	
G	24.4	26.4	0.960	1.039
N	100		3.937	
T		30.4		1.197

<b>BASE QTY</b>	<b>BULK QTY</b>
1000	1000

10 pitches cumulative tolerance on tape +/- 0.2 mm

Center line of cavity

User Direction of Feed

FEED DIRECTION

Bending radius R min.

\* on sales type

**STP12NM50FD / STP12NM50FDFP / STB12NM50FD / STB12NM50FD-1 / STW14NM50FD**

Information furnished is believed to be accurate and reliable. However, STMicroelectronics assumes no responsibility for the consequences of use of such information nor for any infringement of patents or other rights of third parties which may result from its use. No license is granted by implication or otherwise under any patent or patent rights of STMicroelectronics. Specifications mentioned in this publication are subject to change without notice. This publication supersedes and replaces all information previously supplied. STMicroelectronics products are not authorized for use as critical components in life support devices or systems without express written approval of STMicroelectronics.

© The ST logo is a registered trademark of STMicroelectronics

© 2002 STMicroelectronics - Printed in Italy - All Rights Reserved  
STMicroelectronics GROUP OF COMPANIES

Australia - Brazil - Canada - China - Finland - France - Germany - Hong Kong - India - Israel - Italy - Japan - Malaysia - Malta - Morocco  
Singapore - Spain - Sweden - Switzerland - United Kingdom - United States.

© <http://www.st.com>