



STD2NB60 STD2NB60-1

N-CHANNEL 600V - 3.3 Ω - 2.6A DPAK/IPAK
PowerMESH™ MOSFET

Table 1. General Features

Type	V _{bss}	R _{DS(on)}	I _D
STD2NB60	600 V	< 3.6 Ω	2.6 A
STD2NB60-1	600 V	< 3.6 Ω	2.6 A

FEATURES SUMMARY

- TYPICAL R_{DS(on)} = 3.3 Ω
- EXTREMELY HIGH dv/dt CAPABILITY
- 100% AVALANCHE TESTED
- VERY LOW INTRINSIC CAPACITANCES
- GATE CHARGE MINIMIZED

DESCRIPTION

Using the latest high voltage MESH OVERLAY™ process, STMicroelectronics has designed an advanced family of power MOSFETs with outstanding performances. The new patent pending strip layout coupled with the Company's proprietary edge termination structure, gives the lowest R_{DS(on)} per area, exceptional avalanche and dv/dt capabilities and unrivalled gate charge and switching characteristics.

APPLICATIONS

- SWITCH MODE POWER SUPPLIES (SMPS)
- DC-AC CONVERTERS FOR WELDING EQUIPMENT AND UNINTERRUPTIBLE POWER SUPPLIES AND MOTOR DRIVE

Figure 1. Package

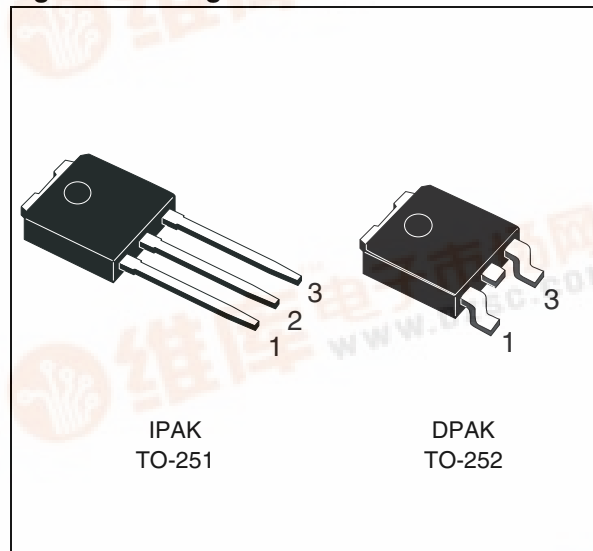

Figure 2. Internal Schematic Diagram

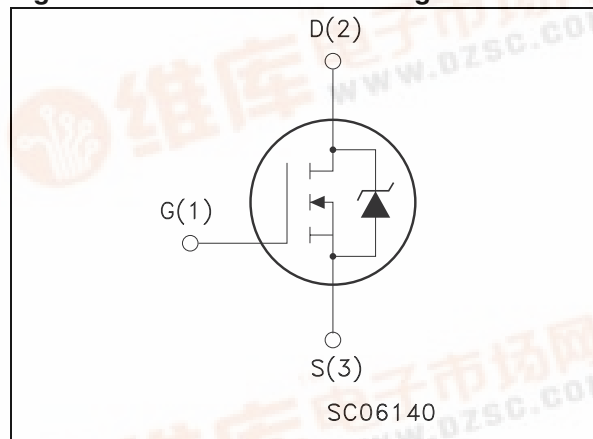

Table 2. Order Codes

Part Number	Marking	Package	Packaging
STD2NB60T4	D2NB60	DPAK	TAPE & REEL
STD2NB60-1	D2NB60	IPAK	TUBE

STD2NB60/STD2NB60-1

Table 3. Absolute Maximum Ratings

Symbol	Parameter	Value	Unit
V _{DS}	Drain-source Voltage (V _{GS} = 0)	600	V
V _{DGR}	Drain- gate Voltage (R _{GS} = 20 kΩ)	600	V
V _{GS}	Gate-source Voltage	± 30	V
I _D	Drain Current (cont.) at T _C = 25 °C	2.6	A
I _D	Drain Current (cont.) at T _C = 100 °C	1.6	A
I _{DM} ⁽¹⁾	Drain Current (pulsed)	10.4	A
P _{tot}	Total Dissipation at T _C = 25 °C	50	W
	Derating Factor	0.4	W/°C
dv/dt ⁽²⁾	Peak Diode Recovery voltage slope	4.5	V/ns
T _{stg}	Storage Temperature	-65 to 150	°C
T _j	Max. Operating Junction Temperature	150	°C

Note: 1. Pulse width limited by safe operating area
2. I_{SD} ≤ 2.6A, di/dt ≤ 200 A/μs, V_{DD} ≤ V_{(BR)DSS}, T_j ≤ T_{JMAX}

Table 4. Thermal Data

Symbol	Parameter	Value	Unit
R _{thj-case}	Thermal Resistance Junction-case Max	2.5	°C/W
R _{thj-amb}	Thermal Resistance Junction-ambient Max	100	°C/W
T _l	Maximum Lead Temperature For Soldering Purpose	275	°C

Table 5. Avalanche Characteristics

Symbol	Parameter	Max Value	Unit
I _{AR}	Avalanche Current, Repetitive or Not-Repetitive (pulse width limited by T _j max, δ < 1%)	2.6	A
E _{AS}	Single Pulse Avalanche Energy (starting T _j = 25 °C; I _D = I _{AR} ; V _{DD} = 50 V)	80	mJ

ELECTRICAL CHARACTERISTICS ($T_{case} = 25^{\circ}\text{C}$ unless otherwise specified)

Table 6. Off

Symbol	Parameter	Test Conditions	Min.	Typ.	Max.	Unit
$V_{(BR)DSS}$	Drain-source Breakdown Voltage	$I_D = 250 \mu\text{A}$ $V_{GS} = 0$	600			V
I_{DSS}	Zero Gate Voltage	$V_{DS} = \text{Max Rating}$			1	μA
	Drain Current ($V_{GS} = 0$)	$V_{DS} = \text{Max Rating}$ $T_c = 125^{\circ}\text{C}$			50	μA
I_{GSS}	Gate-body Leakage Current ($V_{DS} = 0$)	$V_{GS} = \pm 30 \text{ V}$			± 100	nA

Table 7. On (1)

Symbol	Parameter	Test Conditions	Min.	Typ.	Max.	Unit
$V_{GS(th)}$	Gate Threshold Voltage	$V_{DS} = V_{GS}$; $I_D = 250 \mu\text{A}$	3	4	5	V
$R_{DS(on)}$	Static Drain-source On Resistance	$V_{GS} = 10\text{V}$; $I_D = 1.6 \text{ A}$		3.3	3.6	Ω

Note: 1. Pulsed: Pulse duration = 300 μs , duty cycle 1.5 %

Table 8. Dynamic

Symbol	Parameter	Test Conditions	Min.	Typ.	Max.	Unit
$g_{fs}^{(1)}$	Forward Transconductance	$V_{DS} > I_{D(on)} \times R_{DS(on)max}$; $I_D = 1.6 \text{ A}$	1.2	2		S
C_{iss}	Input Capacitance	$V_{DS} = 25 \text{ V}$; $f = 1 \text{ MHz}$; $V_{GS} = 0$		400	520	pF
C_{oss}	Output Capacitance			57	77	pF
C_{rss}	Reverse Transfer Capacitance			7	9	pF

Note: 1. Pulsed: Pulse duration = 300 μs , duty cycle 1.5 %

Table 9. Switching On

Symbol	Parameter	Test Conditions	Min.	Typ.	Max.	Unit
$t_{d(on)}$	Turn-on Time	$V_{DD} = 300 \text{ V}$; $I_D = 1.6 \text{ A}$; $R_G = 4.7 \Omega$ $V_{GS} = 10 \text{ V}$ (see test circuit, Figure 16)		11	17	ns
t_r	Rise Time			7	11	ns
Q_g	Total Gate Charge	$V_{DD} = 480 \text{ V}$; $I_D = 3.3 \text{ A}$; $V_{GS} = 10 \text{ V}$		15	22	nC
Q_{gs}	Gate-Source Charge			6.2		nC
Q_{gd}	Gate-Drain Charge			5.6		nC

Table 10. Switching Off

Symbol	Parameter	Test Conditions	Min.	Typ.	Max.	Unit
$t_{r(Voff)}$	Off-voltage Rise Time	$V_{DD} = 480 \text{ V}$; $I_D = 3.3 \text{ A}$; $R_G = 4.7 \Omega$ $V_{GS} = 10 \text{ V}$ (see test circuit, Figure 18)		11	16	ns
t_f	Fall Time			13	18	ns
t_c	Cross-over Time			18	25	ns

STD2NB60/STD2NB60-1

Table 11. Source Drain Diode

Symbol	Parameter	Test Conditions	Min.	Typ.	Max.	Unit
I_{SD}	Source-drain Current				3.3	A
$I_{SDM}^{(1)}$	Source-drain Current (pulsed)				13.2	A
$V_{SD}^{(2)}$	Forward On Voltage	$I_{SD} = 3.3 \text{ A}; V_{GS} = 0$			1.6	V
t_{rr}	Reverse Recovery Time	$I_{SD} = 3.3 \text{ A}; di/dt = 100 \text{ A}/\mu\text{s}$		500		ns
Q_{rr}	Reverse Recovery Charge	$V_{DD} = 100 \text{ V}; T_j = 150 \text{ }^\circ\text{C}$ (see test circuit, Figure 18)		2.1		μC
I_{RRAM}	Reverse Recovery Charge			8.5		A

Note: 1. Pulse width limited by safe operating area
 2. Pulsed: Pulse duration = 300 μs , duty cycle 1.5 %

Figure 3. Safe Operating Area

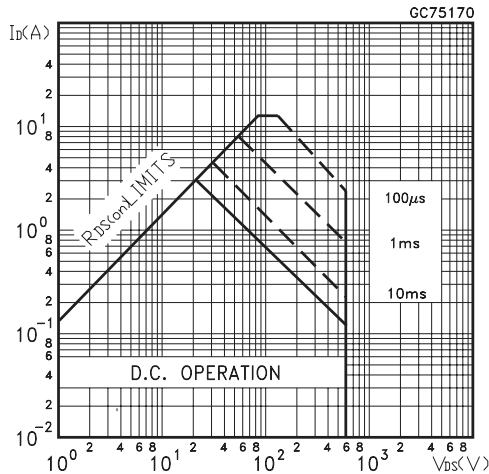

Figure 4. Thermal Impedance

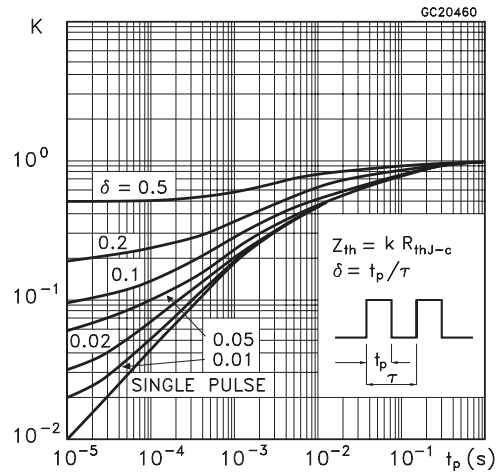

Figure 5. Output Characteristics

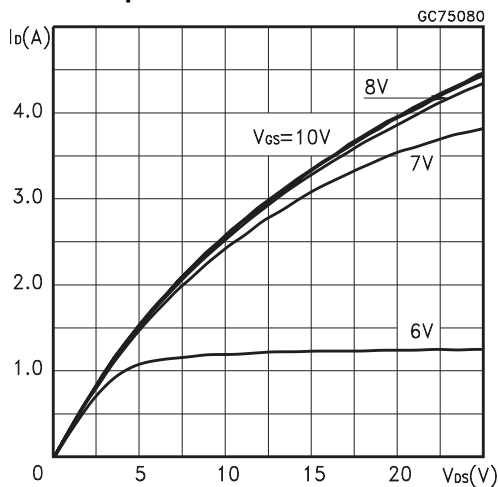

Figure 6. Transfer Characteristics

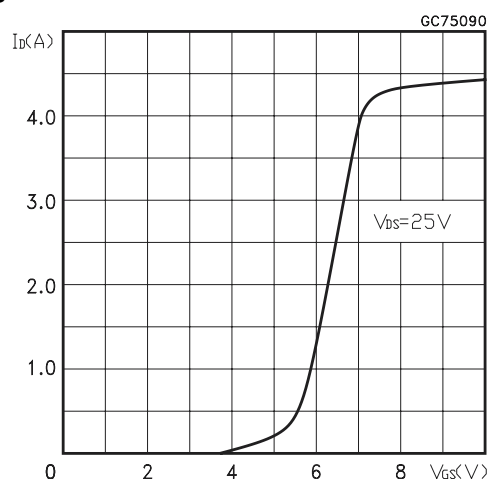

Figure 7. Transconductance

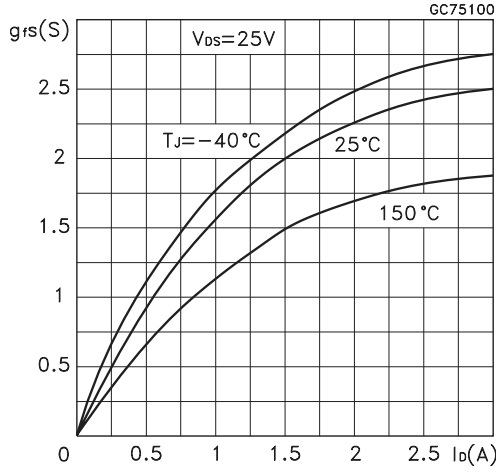

Figure 8. Gate Charge vs Gate-source Voltage

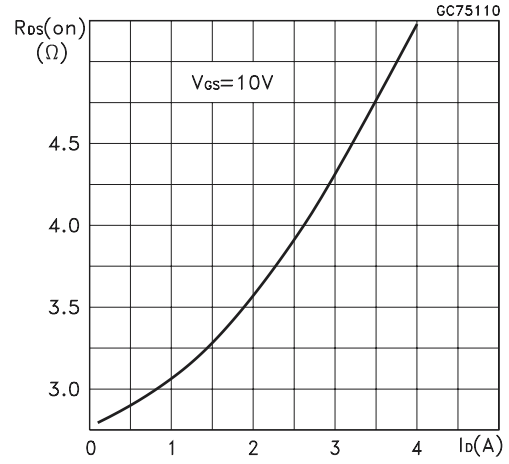

Figure 9. Static Drain-source On Resistance

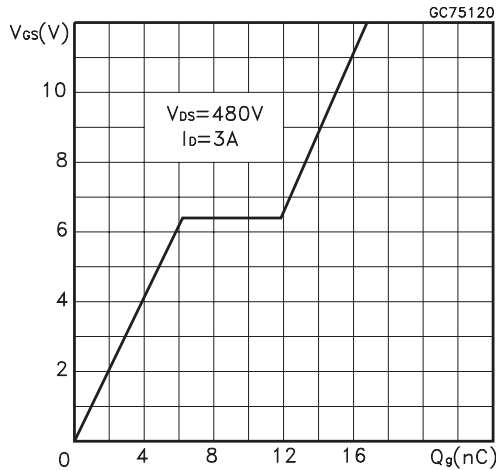

Figure 10. Capacitance Variations

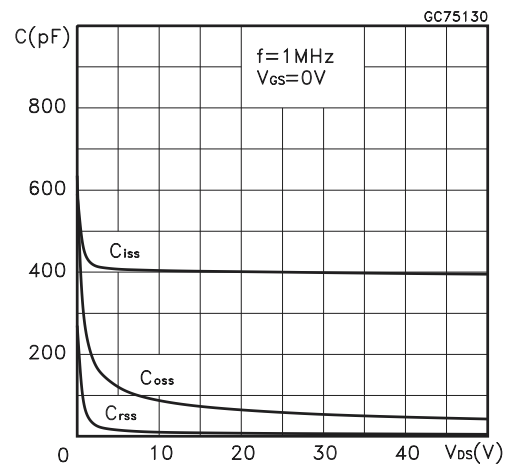

Figure 11. Normalized Gate Threshold Voltage vs Temperature

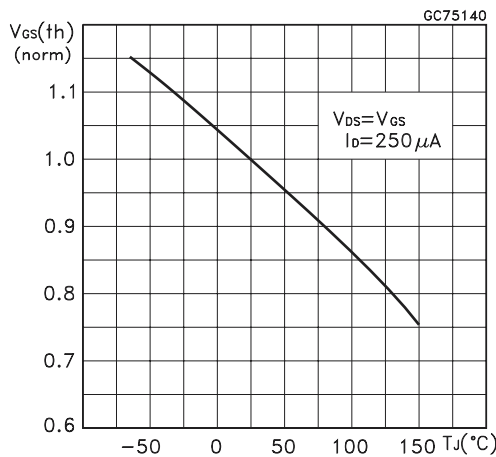

Figure 12. Normalized On Resistance vs Temperature

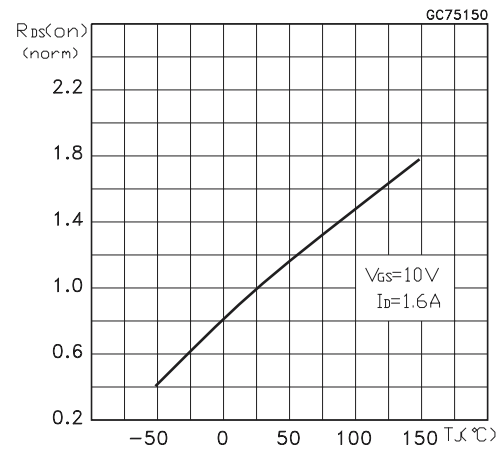

Figure 13. Source-drain Diode Forward Characteristics

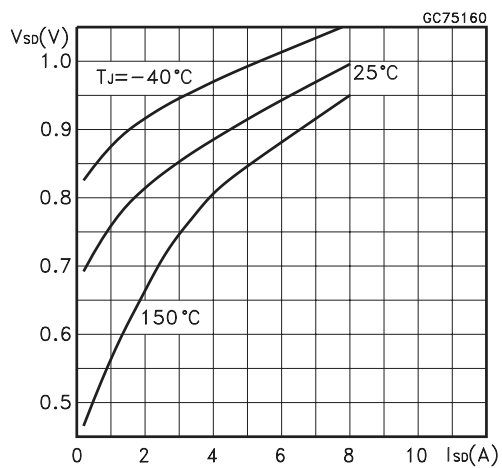

Figure 14. Unclamped Inductive Load Test Circuit

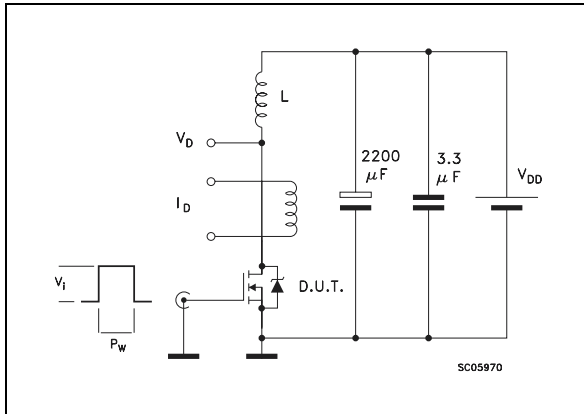

Figure 15. Unclamped Inductive Waveforms

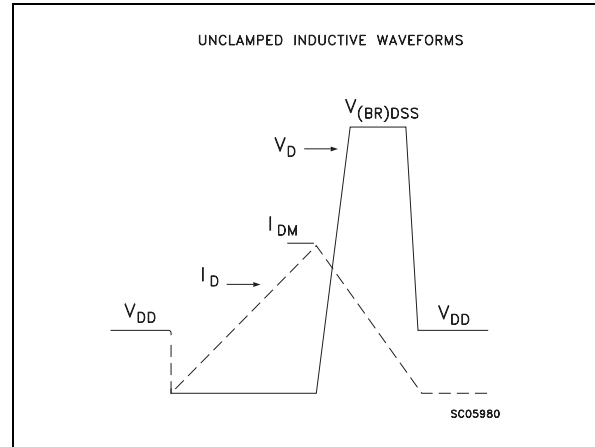

Figure 16. Switching Times Test Circuits For Resistive Load

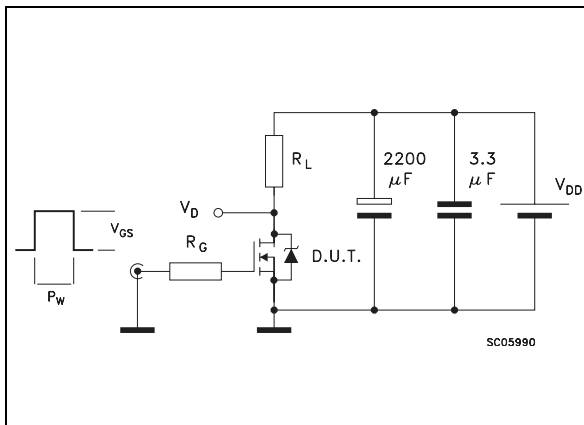

Figure 17. Gate Charge Test Circuit

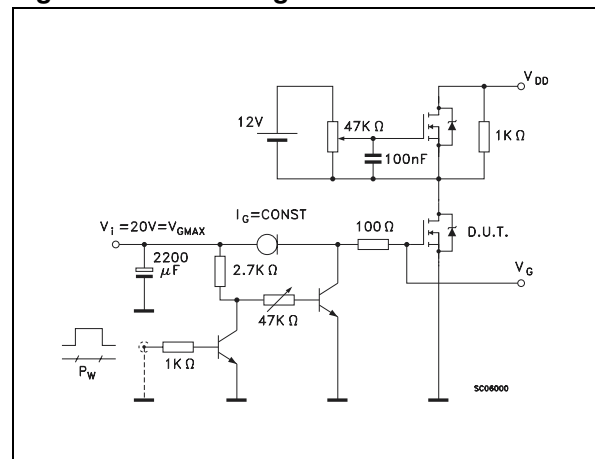
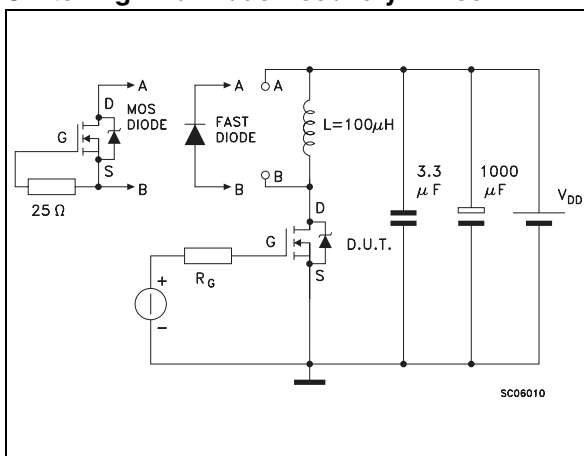

Figure 18. Test Circuit For Inductive Load Switching And Diode Recovery Times



STD2NB60/STD2NB60-1

PACKAGE MECHANICAL

Table 12. DPAK Mechanical Data

Symbol	millimeters			inches		
	Min	Typ	Max	Min	Typ	Max
A	2.20		2.40	0.087		0.094
A1	0.90		1.10	0.035		0.043
A2	0.03		0.23	0.001		0.009
B	0.64		0.90	0.025		0.035
B2	5.20		5.40	0.204		0.213
C	0.45		0.60	0.018	0.024	
C2	0.48		0.60	0.019		0.024
D	6.00		6.20	0.236		0.244
E	6.40		6.60	0.252		0.260
G	4.40		4.60	0.173		0.181
H	9.35		10.10	0.368		0.398
L2		0.8			0.031	
L4	0.60		1.00	0.024		0.039
V2	0°		8°	0°		0°

Figure 19. DPAK Package Dimensions

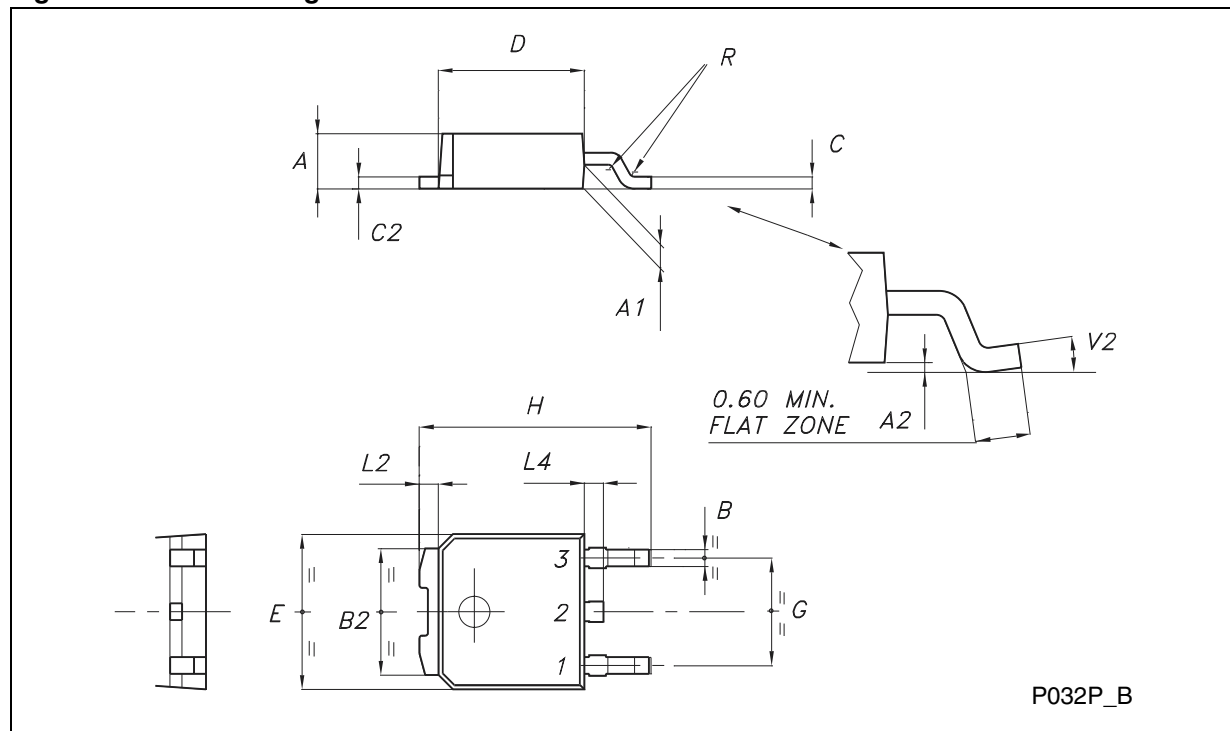

Note: Drawing is not to scale.

Table 13. IPAK Mechanical Data

Symbol	millimeters			inches		
	Min	Typ	Max	Min	Typ	Max
A	2.2		2.4	0.086		0.094
A1	0.9		1.1	0.035		0.043
A3	0.7		1.3	0.027		0.051
B	0.64		0.9	0.025		0.031
B2	5.2		5.4	0.204		0.212
B3			0.85			0.033
B5		0.63			0.012	
B6			0.95			0.037
C	0.45		0.6	0.017		0.023
C2	0.48		0.6	0.019		0.023
D	6		6.2	0.236		0.244
E	6.4		6.6	0.252		0.260
G	4.4		4.6	0.173		0.181
H	15.9		16.3	0.626		0.641
L	9		9.4	0.354		0.370
L1	0.8		1.2	0.031		0.047
L2		0.8	1		0.031	0.039

Figure 20. IPAK Package Dimensions

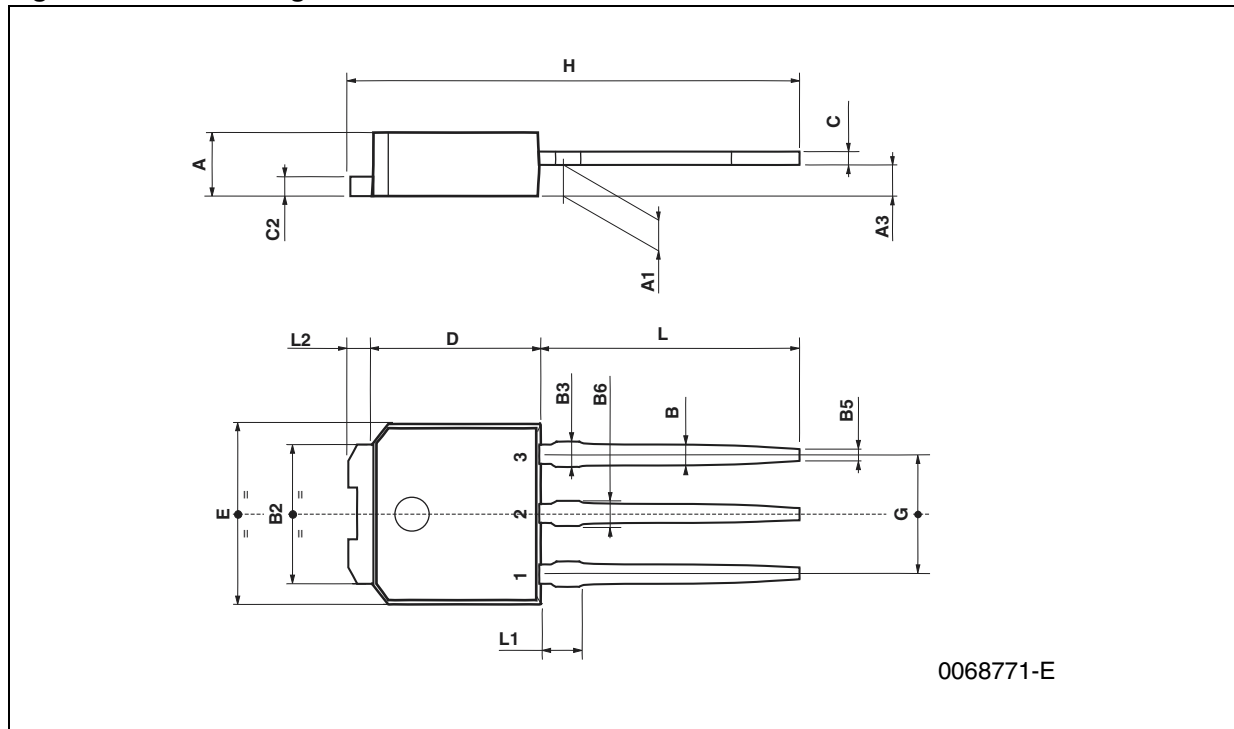

Note: Drawing is not to scale.

REVISION HISTORY

Table 14. Revision History

Date	Revision	Description of Changes
March-1998	1	First Issue
14-Apr-2004	2	Stylesheet update. No content change.

Information furnished is believed to be accurate and reliable. However, STMicroelectronics assumes no responsibility for the consequences of use of such information nor for any infringement of patents or other rights of third parties which may result from its use. No license is granted by implication or otherwise under any patent or patent rights of STMicroelectronics. Specifications mentioned in this publication are subject to change without notice. This publication supersedes and replaces all information previously supplied. STMicroelectronics products are not authorized for use as critical components in life support devices or systems without express written approval of STMicroelectronics.

The ST logo is a registered trademark of STMicroelectronics.
All other names are the property of their respective owners

© 2004 STMicroelectronics - All rights reserved

STMicroelectronics GROUP OF COMPANIES

Australia - Belgium - Brazil - Canada - China - Czech Republic - Finland - France - Germany - Hong Kong - India - Israel - Italy - Japan -
Malaysia - Malta - Morocco - Singapore - Spain - Sweden - Switzerland - United Kingdom - United States

www.st.com