



STD9N10 STD9N10-1

N-CHANNEL 100V - 0.23 Ω - 9A DPAK/IPAK POWER MOS TRANSISTOR

Table 1. General Features

Type	V _{bss}	R _{DS(on)}	I _D
STD9N10	100 V	< 0.27 Ω	9 A
STD9N10-1	100 V	< 0.27 Ω	9 A

FEATURES SUMMARY

- TYPICAL R_{DS(on)} = 0.23 Ω
- AVALANCHE RUGGED TECHNOLOGY
- 100% AVALANCHE TESTED
- REPETITIVE AVALANCHE DATA AT 100°C
- LOW GATE CHARGE
- HIGH CURRENT CAPABILITY
- 175°C OPERATING TEMPERATURE
- APPLICATION ORIENTED CHARACTERIZATION
- THROUGH-HOLE IPAK (TO-251) POWER PACKAGE IN TUBE (SUFFIX "-1")
- SURFACE-MOUNTING DPAK (TO-252) POWER PACKAGE IN TAPE & REEL (SUFFIX "T4")

APPLICATIONS

- HIGH CURRENT, HIGH SPEED SWITCHING
- SOLENOID AND RELAY DRIVERS
- REGULATORS
- DC-DC & DC-AC CONVERTERS
- MOTOR CONTROL, AUDIO AMPLIFIERS
- AUTOMOTIVE ENVIRONMENT (INJECTION, ABS, AIR-BAG, LAMPDRIVERS, Etc.)

Figure 1. Package

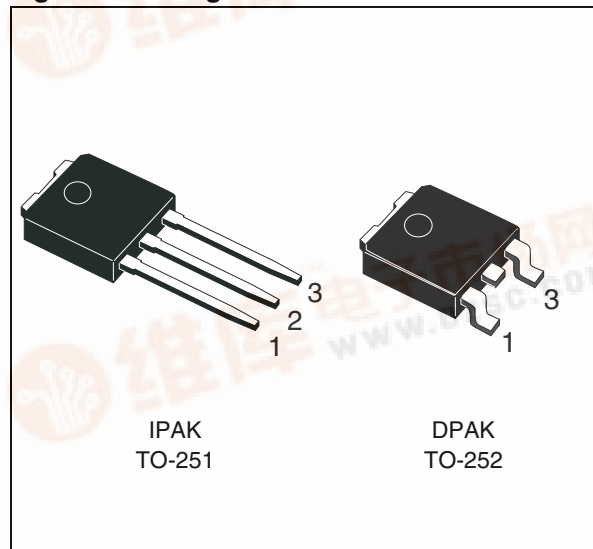

Figure 2. Internal Schematic Diagram

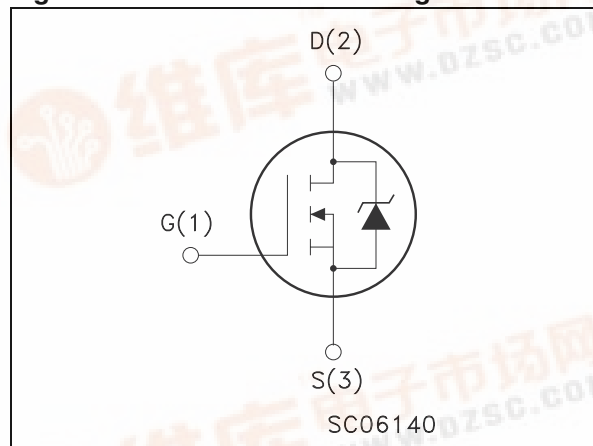

Table 2. Order Codes

Part Number	Marking	Package	Packaging
STD9N10T4	D9N10	DPAK	TAPE & REEL
STD9N10-1	D9N10	IPAK	TUBE

STD9N10/STD9N10-1

Table 3. Absolute Maximum Ratings

Symbol	Parameter	Value	Unit
V _{DS}	Drain-source Voltage (V _{GS} = 0)	100	V
V _{DGR}	Drain- gate Voltage (R _{GS} = 20 kΩ)	100	V
V _{GS}	Gate-source Voltage	± 20	V
I _D	Drain Current (cont.) at T _C = 25 °C	9	A
I _D	Drain Current (cont.) at T _C = 100 °C	6	A
I _{DM} ⁽¹⁾	Drain Current (pulsed)	36	A
P _{tot}	Total Dissipation at T _C = 25 °C	45	W
	Derating Factor	0.3	W/°C
T _{stg}	Storage Temperature	-65 to 175	°C
T _j	Max. Operating Junction Temperature	175	°C

Note: 1. Pulse width limited by safe operating area.

Table 4. Thermal Data

Symbol	Parameter	Value	Unit
R _{thj-case}	Thermal Resistance Junction-case Max	3.33	°C/W
R _{thj-amb}	Thermal Resistance Junction-ambient Max	100	°C/W
T _l	Maximum Lead Temperature For Soldering Purpose	275	°C

Table 5. Avalanche Characteristics

Symbol	Parameter	Max Value	Unit
I _{AR}	Avalanche Current, Repetitive or Not-Repetitive (pulse width limited by T _j max, δ < 1%)	9	A
E _{AS}	Single Pulse Avalanche Energy (starting T _j = 25 °C; I _D = I _{AR} ; V _{DD} = 25 V)	30	mJ
E _{AR}	Repetitive Avalanche Energy (pulse width limited by T _j max, δ < 1%)	7	mJ
I _{AR}	Avalanche Current, Repetitive or Not-Repetitive (T _C = 100 °C, pulse width limited by T _j max, δ < 1%)	6	A

ELECTRICAL CHARACTERISTICS ($T_{case} = 25^{\circ}C$ unless otherwise specified)

Table 6. Off

Symbol	Parameter	Test Conditions	Min.	Typ.	Max.	Unit
$V_{(BR)DSS}$	Drain-source Breakdown Voltage	$I_D = 250 \mu A; V_{GS} = 0$	100			V
I_{DSS}	Zero Gate Voltage	$V_{DS} = \text{Max Rating}$			250	μA
	Drain Current ($V_{GS} = 0$)	$V_{DS} = \text{Max Rating} \times 0.8; T_c = 125^{\circ}C$			1000	μA
I_{GSS}	Gate-body Leakage Current ($V_{DS} = 0$)	$V_{GS} = \pm 20 V$			± 100	nA

Table 7. On ⁽¹⁾

Symbol	Parameter	Test Conditions	Min.	Typ.	Max.	Unit
$V_{GS(th)}$	Gate Threshold Voltage	$V_{DS} = V_{GS}; I_D = 250 \mu A$	2	3	4	V
$R_{DS(on)}$	Static Drain-source On Resistance	$V_{GS} = 10V; I_D = 4.5 A$ $V_{GS} = 10V; I_D = 4.5 A; T_c = 100^{\circ}C$		0.23	0.27 0.54	Ω Ω

Note: 1. Pulsed: Pulse duration = 300 μs , duty cycle 1.5 %

Table 8. Dynamic

Symbol	Parameter	Test Conditions	Min.	Typ.	Max.	Unit
g_{fs} ⁽¹⁾	Forward Transconductance	$V_{DS} > I_{D(on)} \times R_{DS(on)max}; I_D = 4.5 A$	2	4		S
C_{iss}	Input Capacitance	$V_{DS} = 25 V; f = 1 \text{ MHz}; V_{GS} = 0$		330	450	pF
C_{oss}	Output Capacitance			90	120	pF
C_{rss}	Reverse Transfer Capacitance			25	40	pF

Note: 1. Pulsed: Pulse duration = 300 μs , duty cycle 1.5 %

Table 9. Switching On

Symbol	Parameter	Test Conditions	Min.	Typ.	Max.	Unit
$t_{d(on)}$	Turn-on Time	$V_{DD} = 50 V; I_D = 4.5 A; R_G = 4.7 \Omega$		10	15	ns
t_r	Rise Time	$V_{GS} = 10 V$ (see test circuit, Figure 22)		40	60	ns
$(di/dt)_{on}$	Turn-on Current Slope	$V_{DD} = 80 V; I_D = 9 A; R_G = 4.7 \Omega$ $V_{GS} = 10 V$ (see test circuit, Figure 22)		440		A/ μs
Q_g	Total Gate Charge	$V_{DD} = 80 V; I_D = 9 A; V_{GS} = 10 V$		15	25	nC
Q_{gs}	Gate-Source Charge			6		nC
Q_{gd}	Gate-Drain Charge			5		nC

Table 10. Switching Off

Symbol	Parameter	Test Conditions	Min.	Typ.	Max.	Unit
$t_{r(Voff)}$	Off-voltage Rise Time	$V_{DD} = 80 V; I_D = 9 A; R_G = 4.7 \Omega$		15	25	ns
t_f	Fall Time	$V_{GS} = 10 V$ (see test circuit, Figure 24)		25	35	ns
t_c	Cross-over Time			50	70	ns

STD9N10/STD9N10-1

Table 11. Source Drain Diode

Symbol	Parameter	Test Conditions	Min.	Typ.	Max.	Unit
I_{SD}	Source-drain Current				9	A
$I_{SDM}^{(1)}$	Source-drain Current (pulsed)				36	A
$V_{SD}^{(2)}$	Forward On Voltage	$I_{SD} = 9\text{ A}; V_{GS} = 0$			1.5	V
t_{rr}	Reverse Recovery Time	$I_{SD} = 9\text{ A}; di/dt = 100\text{ A}/\mu\text{s}$		80		ns
Q_{rr}	Reverse Recovery Charge	$V_{DD} = 20\text{ V}; T_J = 150\text{ }^\circ\text{C}$ (see test circuit, Figure 24)		0.2		μC
I_{RRAM}	Reverse Recovery Current			5		A

Note: 1. Pulse width limited by safe operating area
 2. Pulsed: Pulse duration = 300 μs , duty cycle 1.5 %

Figure 3. Safe Operating Area

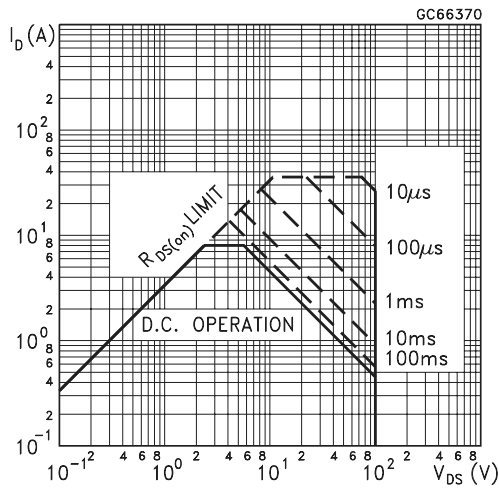

Figure 4. Thermal Impedance

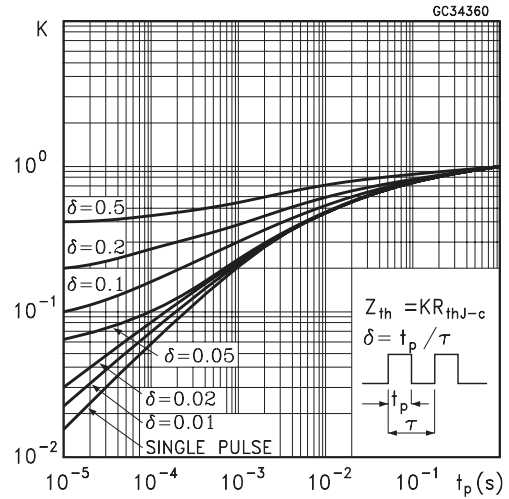

Figure 5. Derating Curve

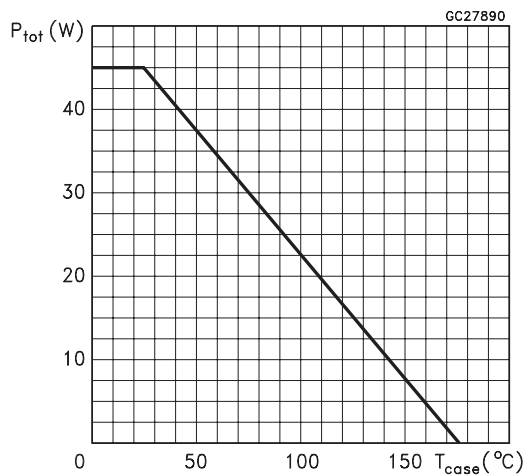

Figure 6. Output Characteristics

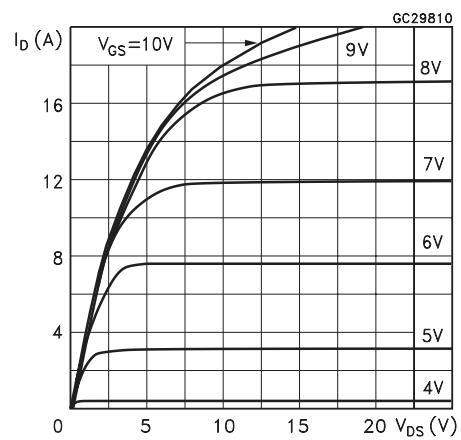

Figure 7. Transfer Characteristics

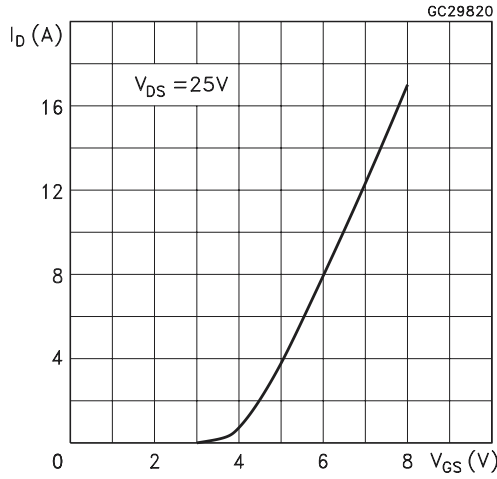

Figure 8. Transconductance

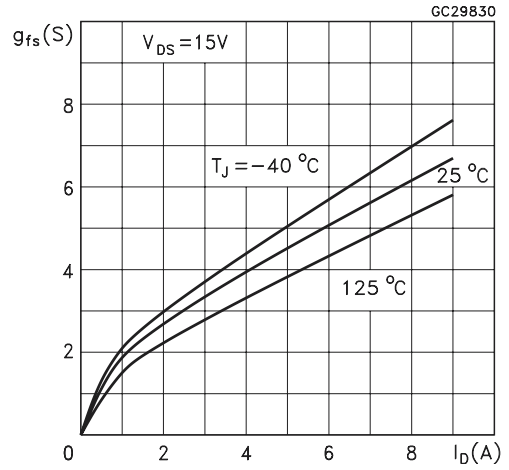

Figure 9. Static Drain-source On Resistance

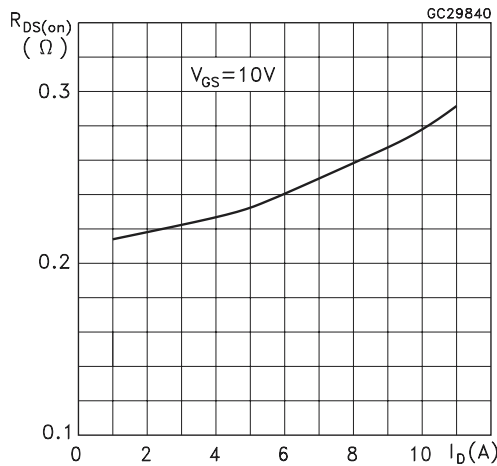

Figure 10. Gate Charge vs Gate-source Voltage

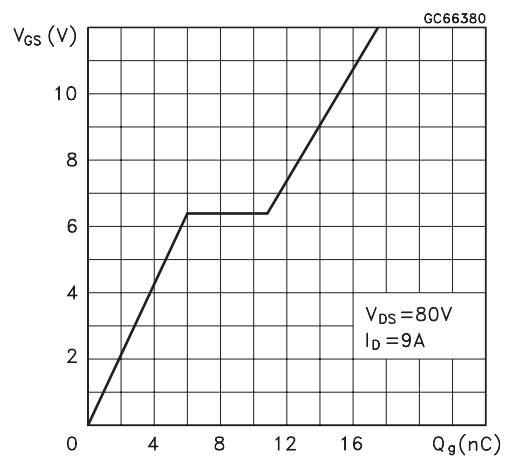

Figure 11. Capacitance Variations

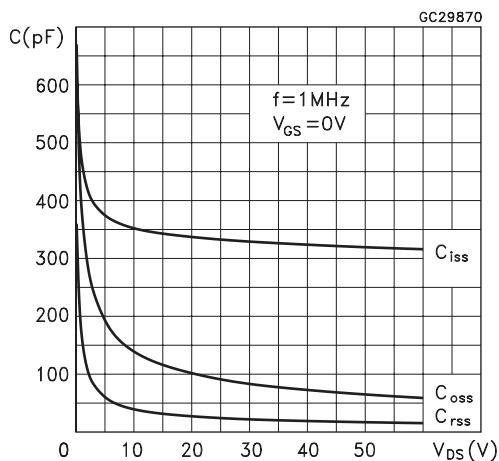

Figure 12. Normalized Gate Threshold Voltage vs Temperature

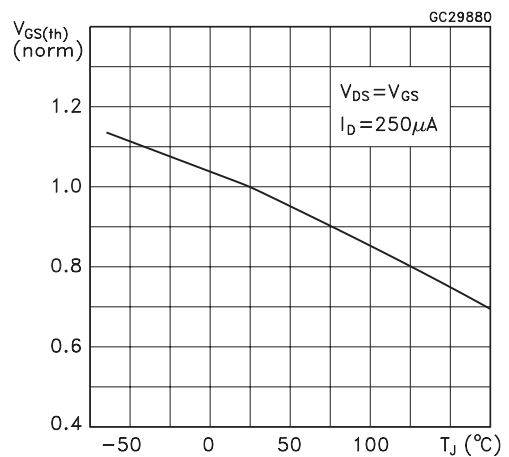

Figure 13. Normalized On Resistance vs Temperature

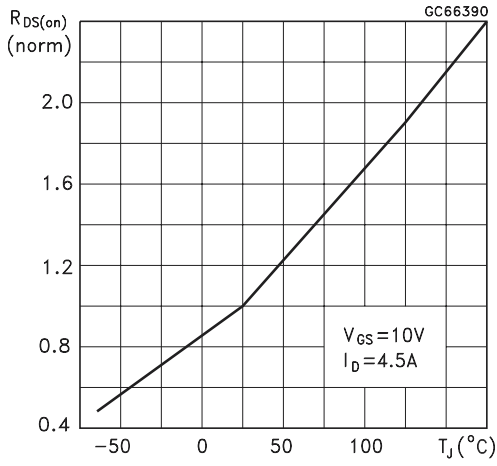

Figure 14. Turn-on Current Slope

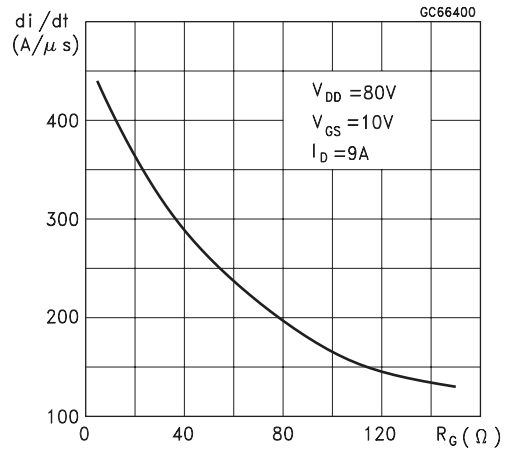

Figure 15. Turn-off Drain-source Voltage Slope

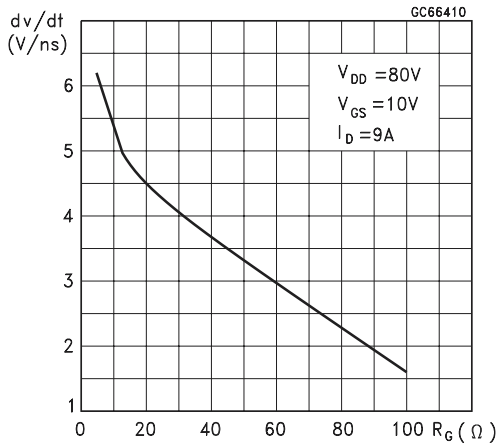

Figure 16. Cross-over Time

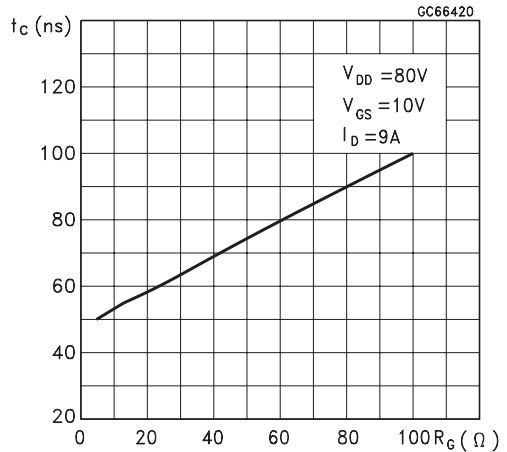

Figure 17. Switching Safe Operating Area

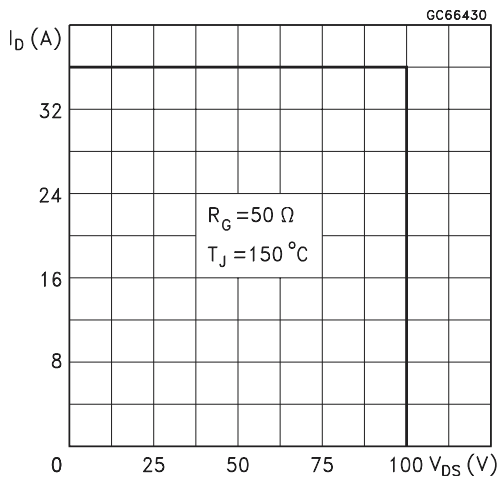

Figure 18. Accidental Overload Area

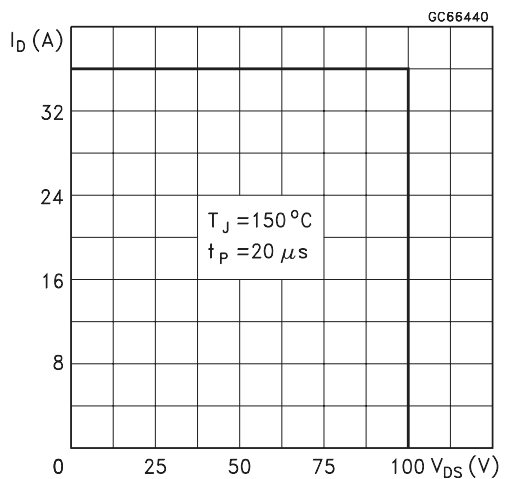

Figure 19. Source-drain Diode Forward Characteristics

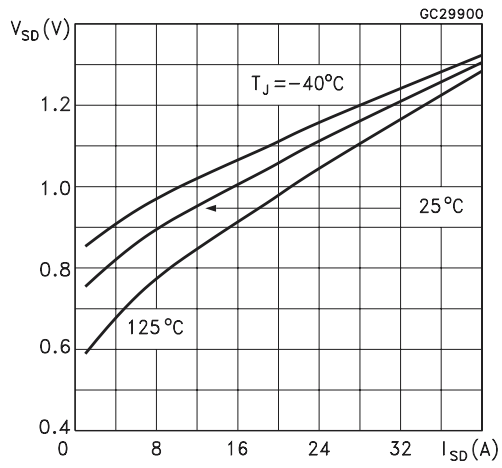

Figure 20. Unclamped Inductive Load Test Circuit

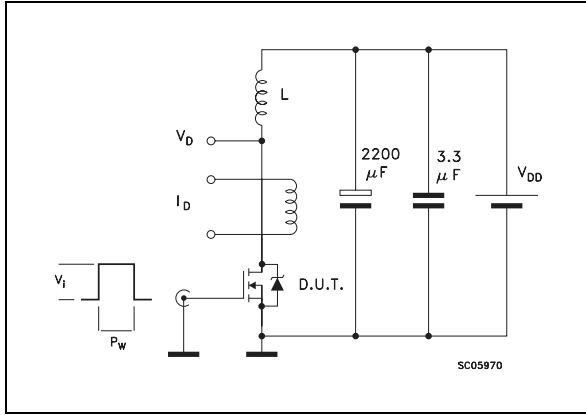

Figure 21. Unclamped Inductive Waveforms

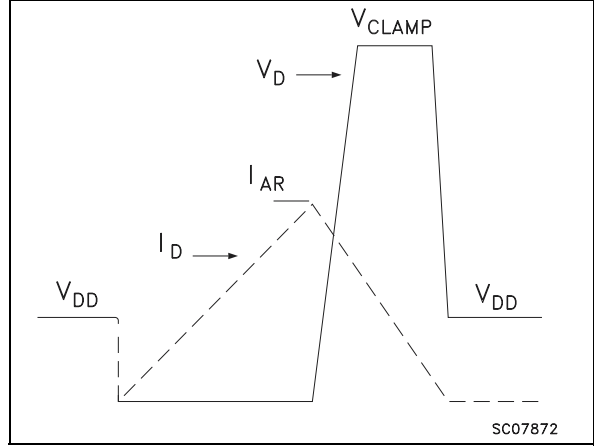

Figure 22. Switching Times Test Circuits For Resistive Load

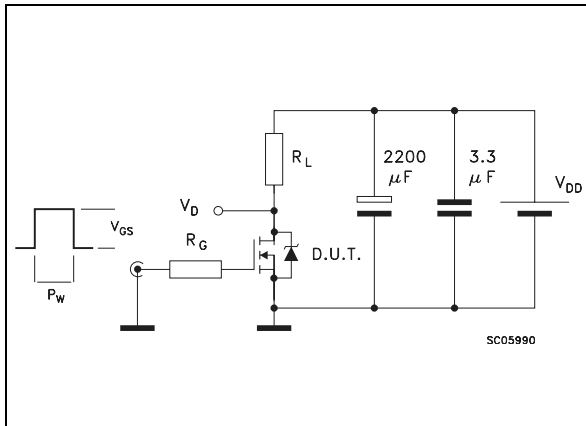

Figure 23. Gate Charge Test Circuit

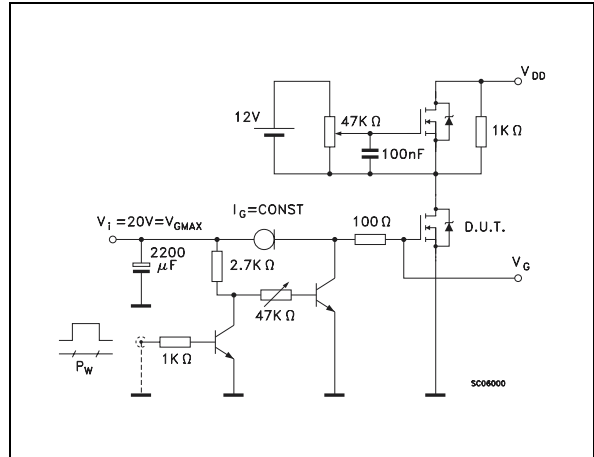
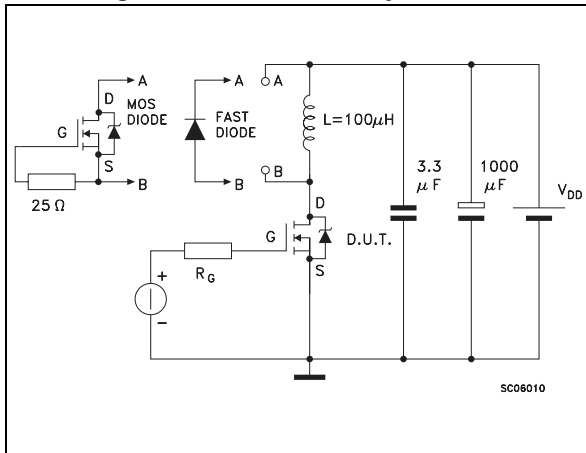

Figure 24. Test Circuit For Inductive Load Switching And Diode Recovery Times



PACKAGE MECHANICAL

Table 12. DPAK Mechanical Data

Symbol	millimeters			inches		
	Min	Typ	Max	Min	Typ	Max
A	2.20		2.40	0.087		0.094
A1	0.90		1.10	0.035		0.043
A2	0.03		0.23	0.001		0.009
B	0.64		0.90	0.025		0.035
B2	5.20		5.40	0.204		0.213
C	0.45		0.60	0.018	0.024	
C2	0.48		0.60	0.019		0.024
D	6.00		6.20	0.236		0.244
E	6.40		6.60	0.252		0.260
G	4.40		4.60	0.173		0.181
H	9.35		10.10	0.368		0.398
L2		0.8			0.031	
L4	0.60		1.00	0.024		0.039
V2	0°		8°	0°		0°

Figure 25. DPAK Package Dimensions

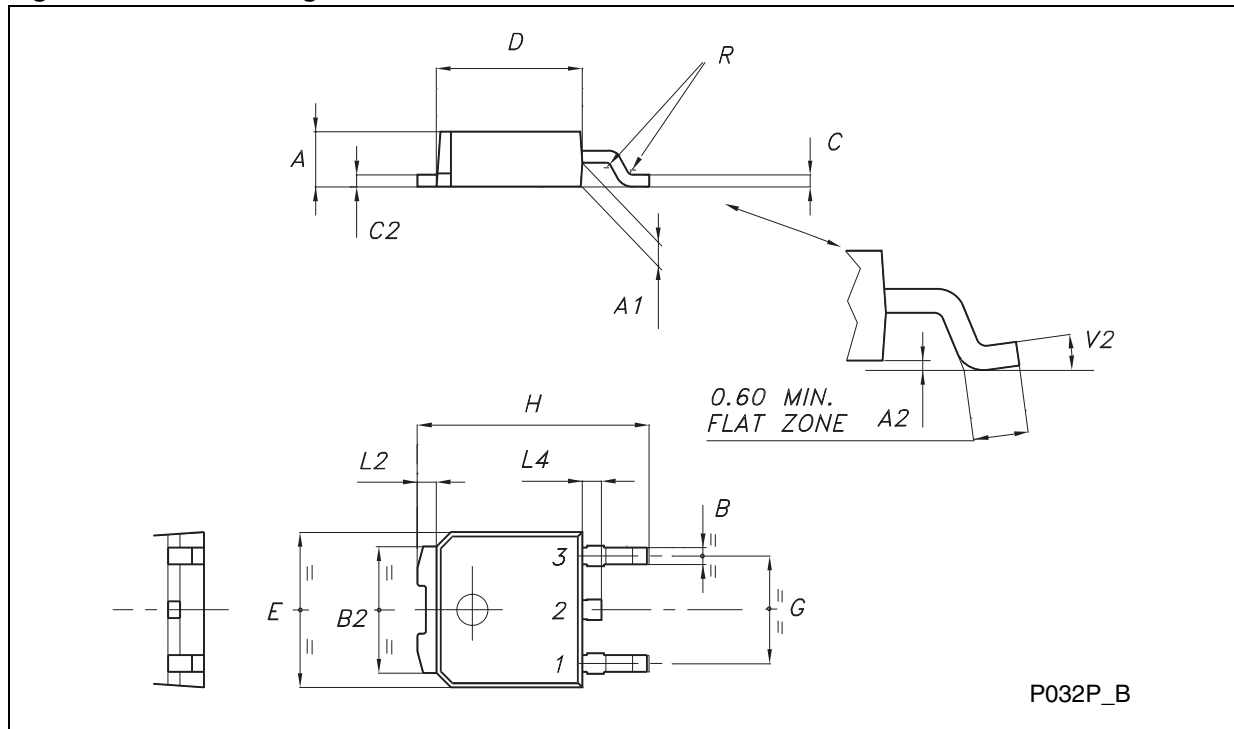

Note: Drawing is not to scale.

STD9N10/STD9N10-1

Table 13. IPAK Mechanical Data

Symbol	millimeters			inches		
	Min	Typ	Max	Min	Typ	Max
A	2.2		2.4	0.086		0.094
A1	0.9		1.1	0.035		0.043
A3	0.7		1.3	0.027		0.051
B	0.64		0.9	0.025		0.031
B2	5.2		5.4	0.204		0.212
B3			0.85			0.033
B5		0.63			0.012	
B6			0.95			0.037
C	0.45		0.6	0.017		0.023
C2	0.48		0.6	0.019		0.023
D	6		6.2	0.236		0.244
E	6.4		6.6	0.252		0.260
G	4.4		4.6	0.173		0.181
H	15.9		16.3	0.626		0.641
L	9		9.4	0.354		0.370
L1	0.8		1.2	0.031		0.047
L2		0.8	1		0.031	0.039

Figure 26. IPAK Package Dimensions

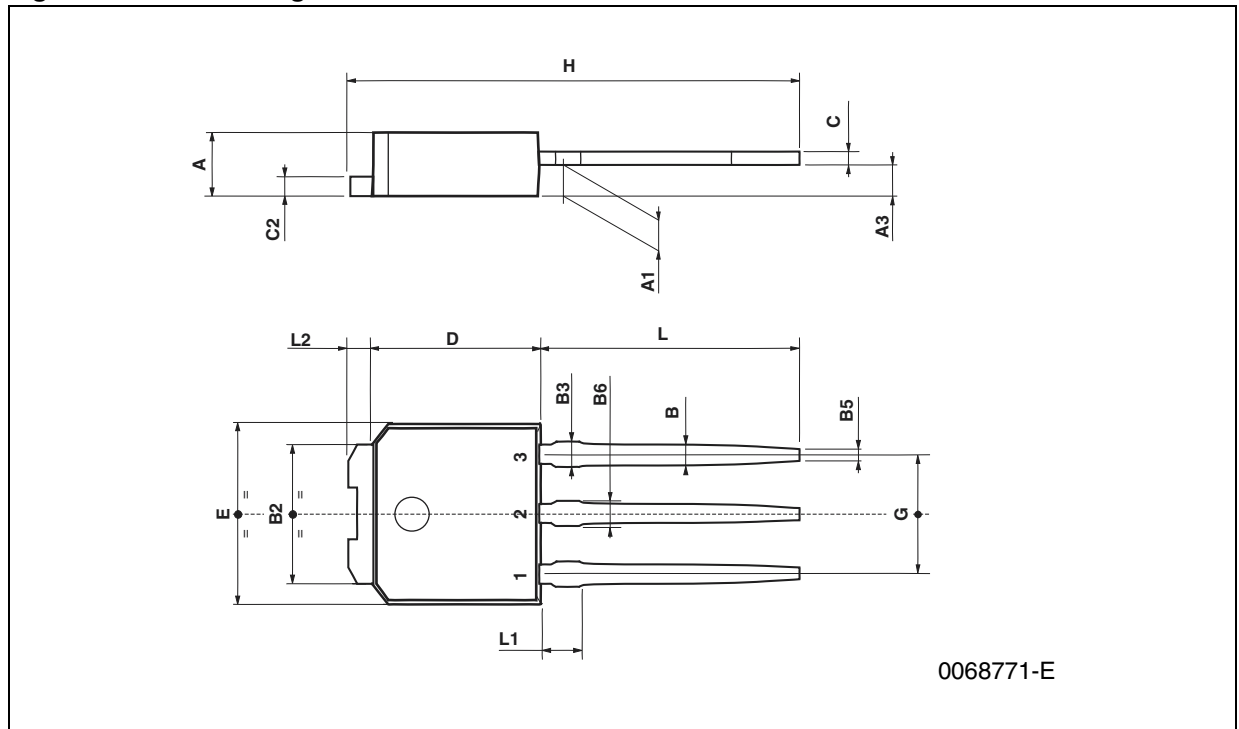

Note: Drawing is not to scale.

REVISION HISTORY

Table 14. Revision History

Date	Revision	Description of Changes
March-1996	1	First Issue
3-May-2004	2	Stylesheet update. No content change.

Information furnished is believed to be accurate and reliable. However, STMicroelectronics assumes no responsibility for the consequences of use of such information nor for any infringement of patents or other rights of third parties which may result from its use. No license is granted by implication or otherwise under any patent or patent rights of STMicroelectronics. Specifications mentioned in this publication are subject to change without notice. This publication supersedes and replaces all information previously supplied. STMicroelectronics products are not authorized for use as critical components in life support devices or systems without express written approval of STMicroelectronics.

The ST logo is a registered trademark of STMicroelectronics.
All other names are the property of their respective owners

© 2004 STMicroelectronics - All rights reserved

STMicroelectronics GROUP OF COMPANIES

Australia - Belgium - Brazil - Canada - China - Czech Republic - Finland - France - Germany - Hong Kong - India - Israel - Italy - Japan -
Malaysia - Malta - Morocco - Singapore - Spain - Sweden - Switzerland - United Kingdom - United States

www.st.com