



# STGB10N60L

## N-CHANNEL 10A - 600V D<sup>2</sup>PAK LOGIC LEVEL IGBT

TYPE	V <sub>CES</sub>	V <sub>CE(sat)</sub>	I <sub>C</sub>
STGB10N60L	600 V	< 1.95 V	10 A

- HIGH INPUT IMPEDANCE (VOLTAGE DRIVEN)
- VERY LOW ON-VOLTAGE DROP (V<sub>cesat</sub>)
- LOW THRESHOLD VOLTAGE (LOGIC LEVEL INPUT)
- HIGH CURRENT CAPABILITY
- OFF LOSSES INCLUDE TAIL CURRENT
- SURFACE-MOUNTING D2PAK (TO-263) POWER PACKAGE IN TUBE (NO SUFFIX) OR IN TAPE & REEL (SUFFIX "T4")

### APPLICATIONS

- ELECTRONIC IGNITION
- LIGHT DIMMER
- STATIC RELAYS

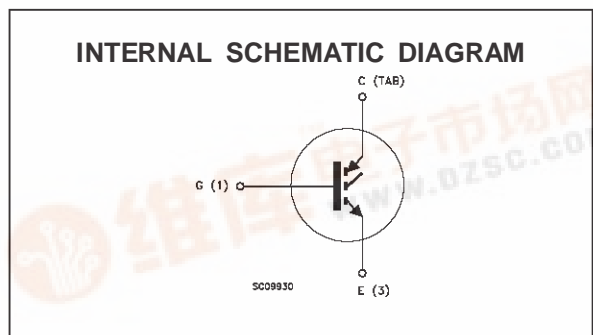
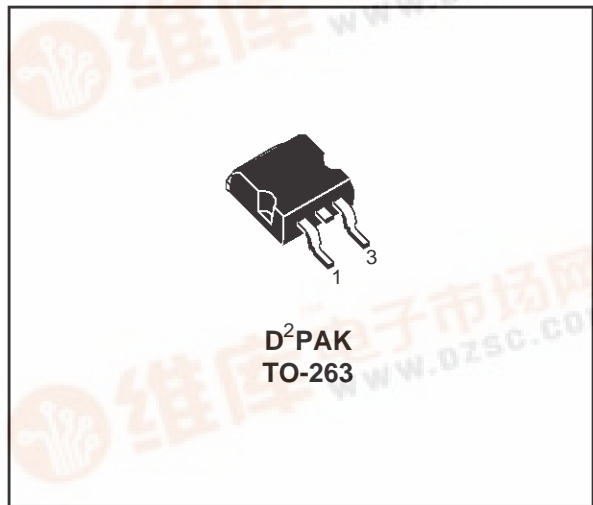

### ABSOLUTE MAXIMUM RATINGS

Symbol	Parameter	Value	Unit
V <sub>CES</sub>	Collector-Emitter Voltage (V <sub>GS</sub> = 0)	600	V
V <sub>ECR</sub>	Reverse Battery Protection	25	V
V <sub>GE</sub>	Gate-Emitter Voltage	± 15	V
I <sub>C</sub>	Collector Current (continuous) at T <sub>c</sub> = 25 °C	25	A
I <sub>C</sub>	Collector Current (continuous) at T <sub>c</sub> = 100 °C	20	A
I <sub>CM(•)</sub>	Collector Current (pulsed)	100	A
P <sub>tot</sub>	Total Dissipation at T <sub>c</sub> = 25 °C	125	W
	Derating Factor	0.83	W/°C
T <sub>stg</sub>	Storage Temperature	-65 to 175	°C
T <sub>j</sub>	Max. Operating Junction Temperature	175	°C

(•) Pulse width limited by safe operating area

## STGB10N60L

### THERMAL DATA

R <sub>thj-case</sub>	Thermal Resistance Junction-case	Max	1.2	°C/W
R <sub>thj-amb</sub>	Thermal Resistance Junction-ambient	Max	62.5	°C/W
R <sub>thc-sink</sub>	Thermal Resistance Case-sink	Typ	0.1	°C/W

### ELECTRICAL CHARACTERISTICS (T<sub>j</sub> = - 40 to 150 °C unless otherwise specified)

#### OFF

Symbol	Parameter	Test Conditions	Min.	Typ.	Max.	Unit
V <sub>BR(ces)</sub>	Collector-Emitter Breakdown Voltage	I <sub>C</sub> = 250 μA V <sub>GE</sub> = 0	600			V
I <sub>CES</sub>	Collector cut-off (V <sub>GE</sub> = 0)	V <sub>CE</sub> = Max Rating T <sub>j</sub> = 25 °C V <sub>CE</sub> = Max Rating T <sub>j</sub> = 125 °C			25 100	μA μA
I <sub>GES</sub>	Gate-Emitter Leakage Current (V <sub>CE</sub> = 0)	V <sub>GE</sub> = ± 15 V V <sub>CE</sub> = 0			± 100	nA

#### ON (\*)

Symbol	Parameter	Test Conditions	Min.	Typ.	Max.	Unit
V <sub>GE(th)</sub>	Gate Threshold Voltage	V <sub>CE</sub> = V <sub>GE</sub> I <sub>C</sub> = 250 μA V <sub>CE</sub> = V <sub>GE</sub> I <sub>C</sub> = 250 μA T <sub>j</sub> = 25 °C	0.6 1.0		2.4 2.0	V V
V <sub>CE(SAT)</sub>	Collector-Emitter Saturation Voltage	V <sub>GE</sub> = 4.5 V I <sub>C</sub> = 8 A T <sub>j</sub> = - 40 °C V <sub>GE</sub> = 4.5 V I <sub>C</sub> = 9.5 A T <sub>j</sub> = 25 °C V <sub>GE</sub> = 4.5 V I <sub>C</sub> = 8 A T <sub>j</sub> = 150 °C		1.5 1.4 1.25	2.0	V V V
I <sub>C</sub>	Collector Current	V <sub>GE</sub> = 4.5 V V <sub>CE</sub> = 7 V	15	45		A

### DYNAMIC

Symbol	Parameter	Test Conditions	Min.	Typ.	Max.	Unit
g <sub>fs</sub>	Forward Transconductance	V <sub>CE</sub> = 25 V I <sub>C</sub> = 8 A T <sub>j</sub> = 25 °C	7	12		S
C <sub>ies</sub> C <sub>oes</sub> C <sub>res</sub>	Input Capacitance Output Capacitance Reverse Transfer Capacitance	V <sub>CE</sub> = 25 V f = 1 MHz V <sub>GE</sub> = 0		1800 120 19	2600 165 26	pF pF pF
Q <sub>G</sub>	Gate Charge	V <sub>CE</sub> = 400 V I <sub>C</sub> = 8 A V <sub>GE</sub> = 5 V		30		nC

### FUNCTIONAL CHARACTERISTICS

Symbol	Parameter	Test Conditions	Min.	Typ.	Max.	Unit
I <sub>CL</sub>	Latching Current	V <sub>clamp</sub> = 480 V dV/dt = 200 V/μs T <sub>j</sub> = 125 °C	20			A
E <sub>CF</sub>	Forward Clamping Energy	T <sub>start</sub> = 55 °C V <sub>clamp</sub> = 480 V I <sub>C</sub> = 10 A L = 4.2 mH - Single Pulse	210			mJ
E <sub>AR</sub>	Reverse Avalanche Energy		10			mJ

**ELECTRICAL CHARACTERISTICS** (continued)

**SWITCHING ON**

Symbol	Parameter	Test Conditions	Min.	Typ.	Max.	Unit
$t_{d(on)}$	Delay Time	$V_{CC} = 480\text{ V}$		0.7		$\mu\text{s}$
$t_r$	Rise Time	$V_{GE} = 5\text{ V}$		1.9		$\mu\text{s}$
$(di/dt)_{on}$	Turn-on Current Slope	$V_{CC} = 480\text{ V}$ $R_G = 1\text{ K}\Omega$		5		A/ $\mu\text{s}$
$E_{on}$	Turn-on Switching Losses	$I_C = 8\text{ A}$ $V_{GE} = 5\text{ V}$ $T_j = 125\text{ }^\circ\text{C}$		2.5		mJ

**SWITCHING OFF**

Symbol	Parameter	Test Conditions	Min.	Typ.	Max.	Unit
$t_c$	Cross-Over Time	$V_{CC} = 480\text{ V}$		4		$\mu\text{s}$
$t_r(V_{off})$	Off Voltage Rise Time	$R_{GE} = 1\text{ K}\Omega$		2.5		$\mu\text{s}$
$t_f$	Fall Time	$V_{GE} = 5\text{ V}$		1.5		$\mu\text{s}$
$E_{off(**)}$	Turn-off Switching Loss	$T_j = 25\text{ }^\circ\text{C}$		9.0		mJ
$t_c$	Cross-Over Time	$V_{CC} = 480\text{ V}$		6		$\mu\text{s}$
$t_r(V_{off})$	Off Voltage Rise Time	$R_{GE} = 1\text{ K}\Omega$		3.3		$\mu\text{s}$
$t_f$	Fall Time	$V_{GE} = 5\text{ V}$		2.5		$\mu\text{s}$
$E_{off(**)}$	Turn-off Switching Loss	$T_j = 125\text{ }^\circ\text{C}$		10.8		mJ

(●) Pulse width limited by safe operating area  
 (\*) Pulsed: Pulse duration = 300  $\mu\text{s}$ , duty cycle 1.5 %  
 (\*\*) Losses Include Also The Tail (Jedec Standardization)

**Safe Operating Area**

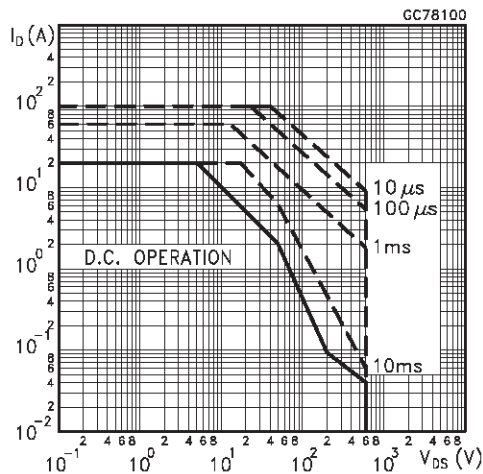

**Thermal Impedance**

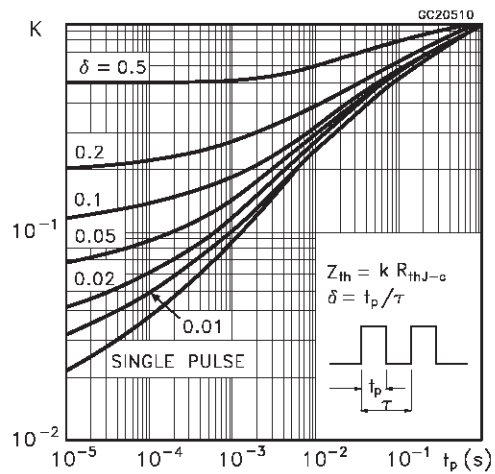

# STGB10N60L

Output Characteristics

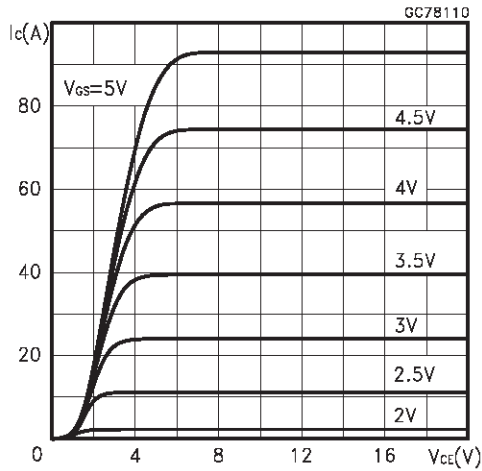

Transfer Characteristics

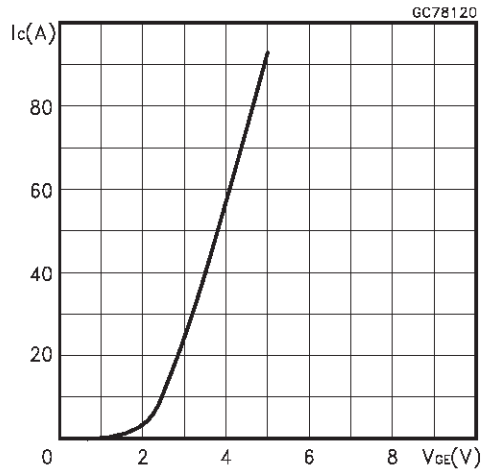

Transconductance

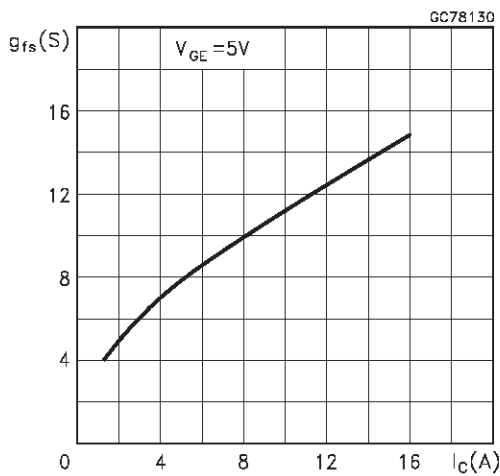

Collector-Emitter On Voltage vs Temperature

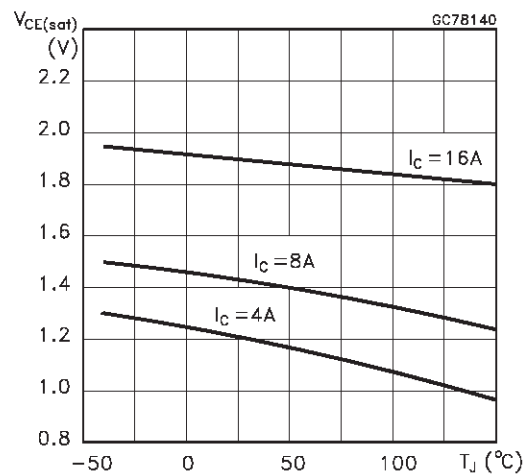

Collector-Emitter On Voltage vs Collector Current

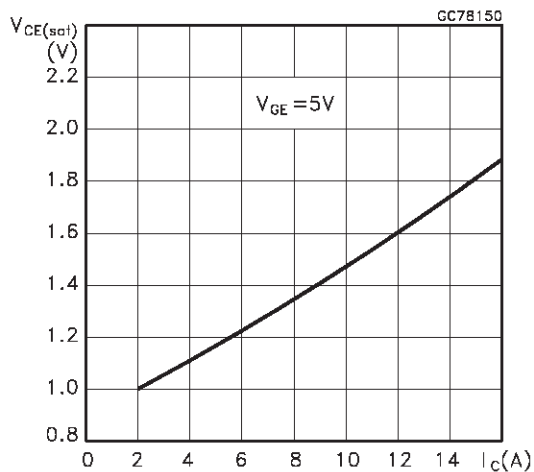

Capacitance Variations

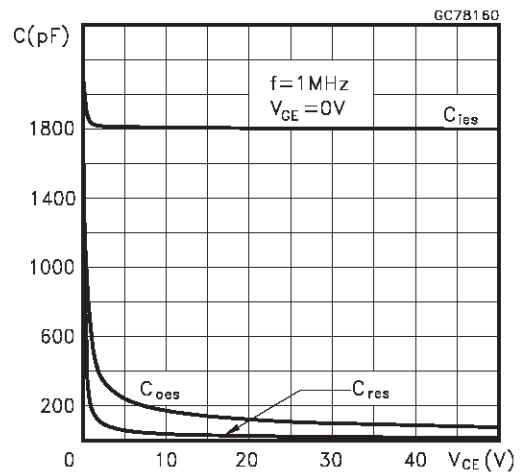

Gate Charge vs Gate-Emitter Voltage

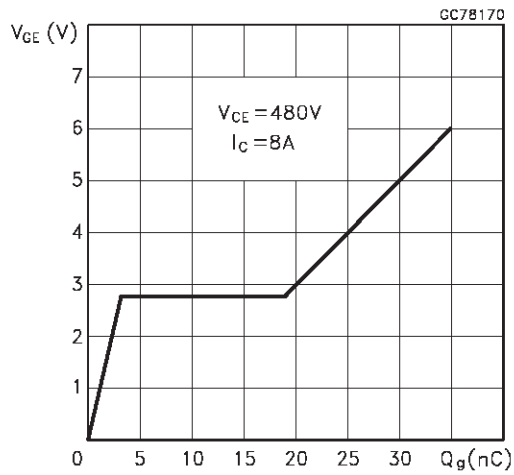

Latching Current vs Rg

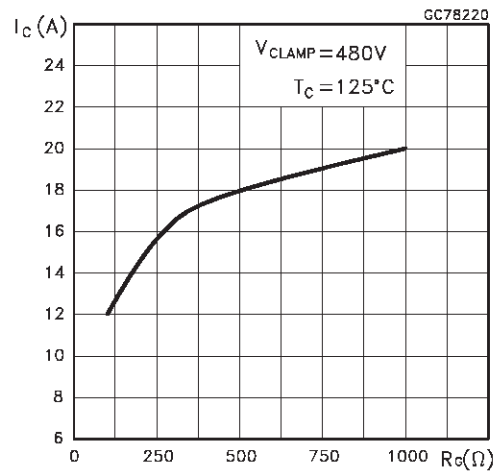

Gate Threshold vs Temperature

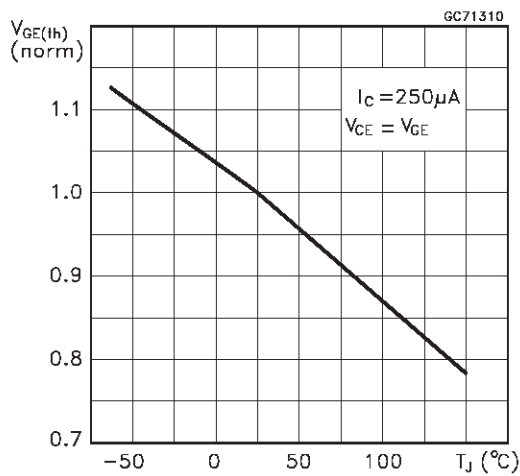

Off Losses vs Collector Current

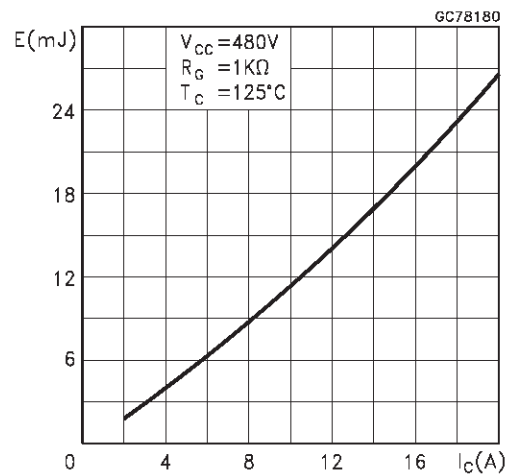

Off Losses vs Gate Resistance

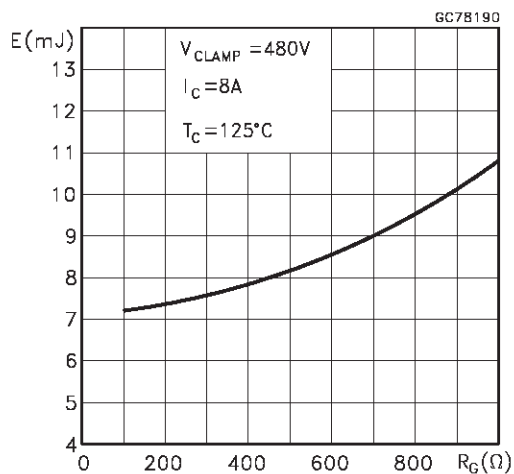

Off Losses vs Temperature

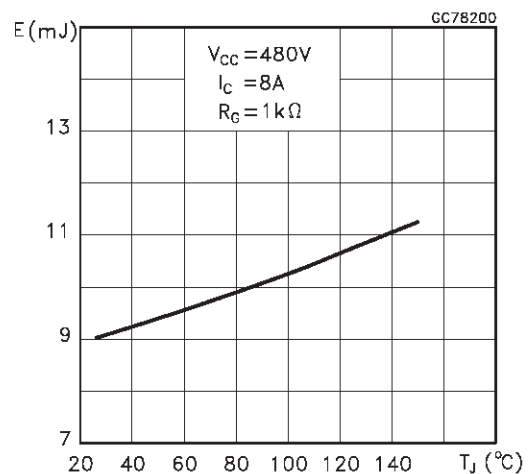

# STGB10N60L

## Switching Off Safe Operatin Area

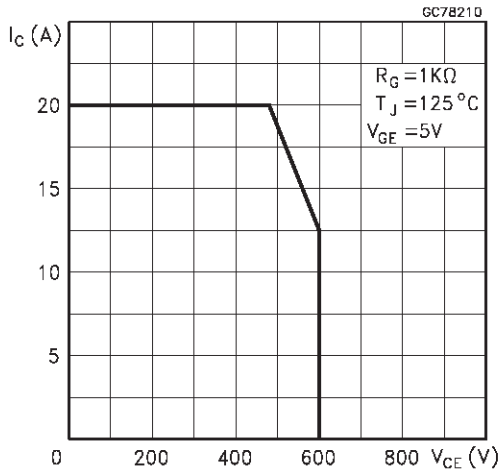

Fig. 1: Gate Charge test Circuit

Fig. 2: Switching Times Test Circuit For Resistive Load

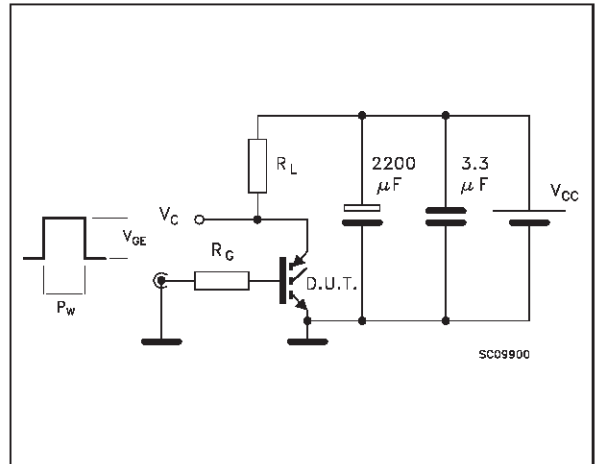
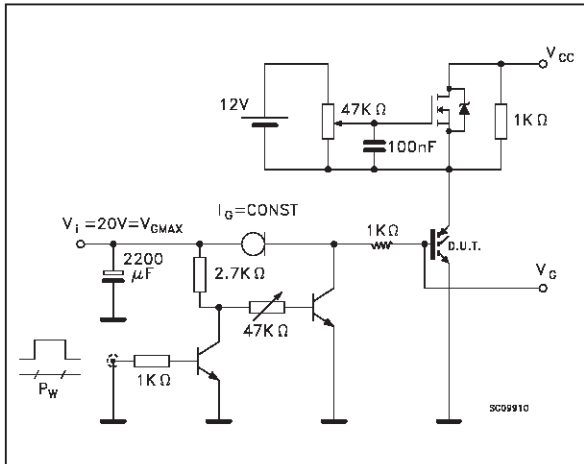
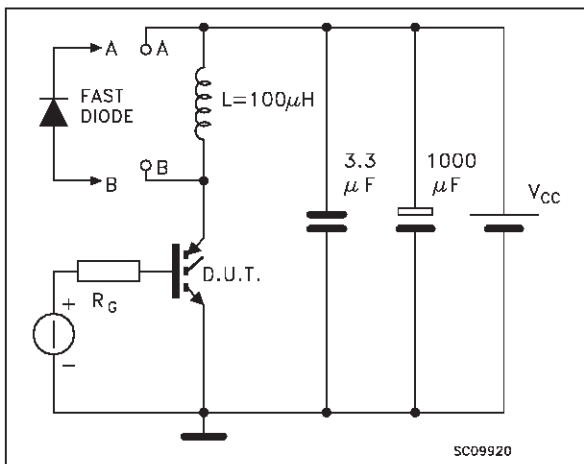
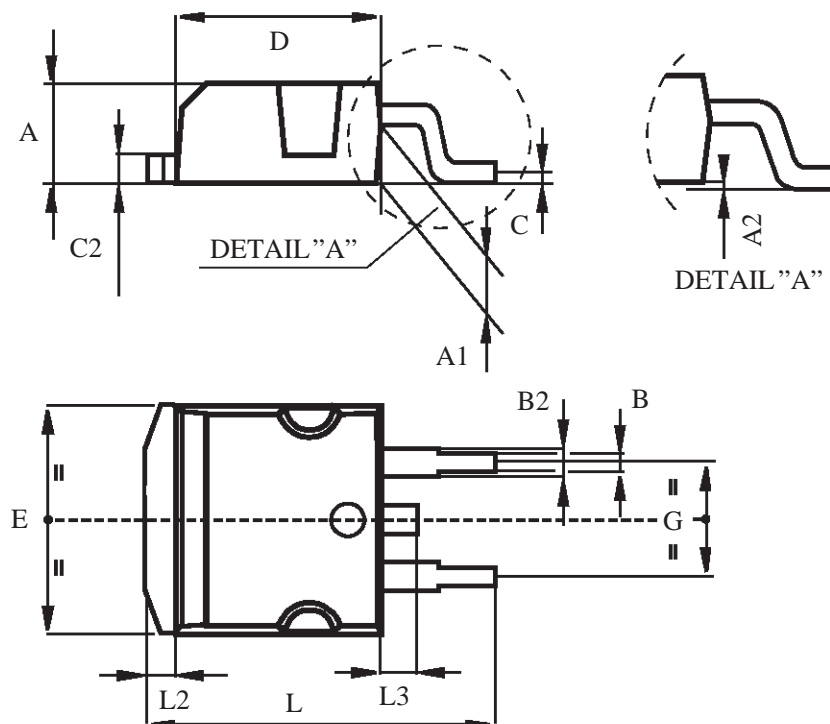

Fig. 3: Test Circuit For Inductive Load Switching



TO-263 (D<sup>2</sup>PAK) MECHANICAL DATA

DIM.	mm			inch		
	MIN.	TYP.	MAX.	MIN.	TYP.	MAX.
A	4.4		4.6	0.173		0.181
A1	2.49		2.69	0.098		0.106
B	0.7		0.93	0.027		0.036
B2	1.14		1.7	0.044		0.067
C	0.45		0.6	0.017		0.023
C2	1.21		1.36	0.047		0.053
D	8.95		9.35	0.352		0.368
E	10		10.4	0.393		0.409
G	4.88		5.28	0.192		0.208
L	15		15.85	0.590		0.624
L2	1.27		1.4	0.050		0.055
L3	1.4		1.75	0.055		0.068



P011P6/E

Information furnished is believed to be accurate and reliable. However, STMicroelectronics assumes no responsibility for the consequences of use of such information nor for any infringement of patents or other rights of third parties which may result from its use. No license is granted by implication or otherwise under any patent or patent rights of STMicroelectronics. Specification mentioned in this publication are subject to change without notice. This publication supersedes and replaces all information previously supplied. STMicroelectronics products are not authorized for use as critical components in life support devices or systems without express written approval of STMicroelectronics.

The ST logo is a trademark of STMicroelectronics

© 1999 STMicroelectronics – Printed in Italy – All Rights Reserved  
STMicroelectronics GROUP OF COMPANIES

Australia - Brazil - China - Finland - France - Germany - Hong Kong - India - Italy - Japan - Malaysia - Malta - Morocco -  
Singapore - Spain - Sweden - Switzerland - United Kingdom - U.S.A.