



STGP12NB60HD

N-CHANNEL 12A - 600V TO-220

PowerMESH™ IGBT

TYPE	V _{CES}	V _{CE(sat)}	I _C
STGP12NB60HD	600 V	< 2.8 V	12 A

- HIGH INPUT IMPEDANCE
- LOW ON-VOLTAGE DROP (V_{CEsat})
- OFF LOSSES INCLUDE TAIL CURRENT
- LOW GATE CHARGE
- HIGH CURRENT CAPABILITY
- VERY HIGH FREQUENCY OPERATION
- CO-PACKAGED WITH TURBOSWITCH
- ANTIPARALLEL DIODE

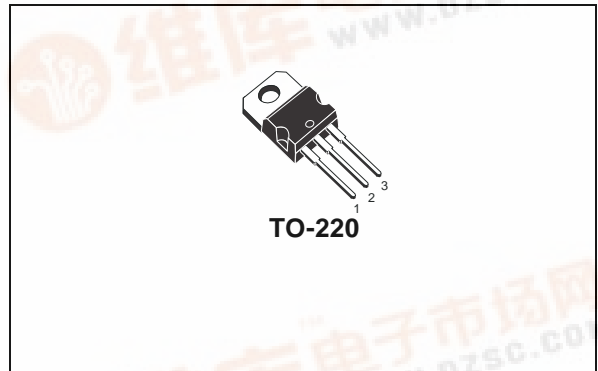

DESCRIPTION

Using the latest high voltage technology based on a patented strip layout, STMicroelectronics has designed an advanced family of IGBTs, the PowerMESH™ IGBTs, with outstanding performances.

The suffix "H" identifies a family optimized for high frequency applications (up to 50kHz) in order to achieve very high switching performances (reduced t_{fall}) maintaining a low voltage drop.

APPLICATIONS

- HIGH FREQUENCY MOTOR CONTROLS
- SMPS and PFC IN BOTH HARD SWITCH AND RESONANT TOPOLOGIES
- UPS

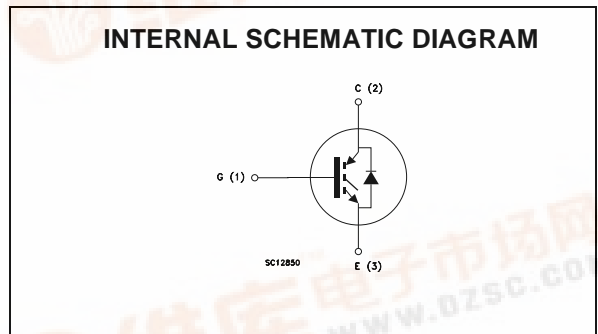

ABSOLUTE MAXIMUM RATINGS

Symbol	Parameter	Value	Unit
V _{CES}	Collector-Emitter Voltage (V _{GS} = 0)	600	V
V _{ECR}	Emitter-Collector Voltage	20	V
V _{GE}	Gate-Emitter Voltage	± 20	V
I _C	Collector Current (continuous) at T _C = 25°C	24	A
I _C	Collector Current (continuous) at T _C = 100°C	12	A
I _{CM} (■)	Collector Current (pulsed)	96	A
P _{TOT}	Total Dissipation at T _C = 25°C	100	W
	Derating Factor	0.8	W/°C
T _{stg}	Storage Temperature	-65 to 150	°C
T _j	Max. Operating Junction Temperature	150	°C

(■) Pulse width limited by safe operating area

STGP12NB60HD

THERMAL DATA

Rthj-case	Thermal Resistance Junction-case Max	1.25	°C/W
Rthj-amb	Thermal Resistance Junction-ambient Max	62.5	°C/W
Rthc-sink	Thermal Resistance Case-sink Typ	0.5	°C/W

ELECTRICAL CHARACTERISTICS (T_{CASE} = 25 °C UNLESS OTHERWISE SPECIFIED)

OFF

Symbol	Parameter	Test Conditions	Min.	Typ.	Max.	Unit
V _{BR(CES)}	Collector-Emitter Breakdown Voltage	I _C = 250 μA, V _{GE} = 0	600			V
I _{CES}	Collector cut-off (V _{GE} = 0)	V _{CE} = Max Rating, T _C = 25 °C V _{CE} = Max Rating, T _C = 125 °C			10 100	μA μA
I _{GES}	Gate-Emitter Leakage Current (V _{CE} = 0)	V _{GE} = ± 20V, V _{CE} = 0			±100	nA

ON (1)

Symbol	Parameter	Test Conditions	Min.	Typ.	Max.	Unit
V _{GE(th)}	Gate Threshold Voltage	V _{CE} = V _{GE} , I _C = 250 μA	3		5	V
V _{CE(sat)}	Collector-Emitter Saturation Voltage	V _{GE} = 15V, I _C = 12 A V _{GE} = 15V, I _C = 12 A, T _J = 125°C		2.0 1.7	2.8	V V

DYNAMIC

Symbol	Parameter	Test Conditions	Min.	Typ.	Max.	Unit
g _{fs}	Forward Transconductance	V _{CE} = 15 V, I _C = 12 A		10		S
C _{ies}	Input Capacitance	V _{CE} = 25V, f = 1 MHz, V _{GE} = 0		920		pF
C _{oes}	Output Capacitance			120		pF
C _{res}	Reverse Transfer Capacitance			27		pF
Q _g Q _{ge} Q _{gc}	Total Gate Charge Gate-Emitter Charge Gate-Collector Charge	V _{CE} = 480V, I _C = 12 A, V _{GE} = 15V		68 10 30		nC nC nC
I _{CL}	Latching Current	V _{clamp} = 480 V, T _J = 150°C R _G = 10 Ω	48			A

SWITCHING ON

Symbol	Parameter	Test Conditions	Min.	Typ.	Max.	Unit
t _{d(on)} t _r	Turn-on Delay Time Rise Time	V _{CC} = 480 V, I _C = 12 A R _G = 10Ω, V _{GE} = 15 V		5 46		ns ns
(di/dt) _{on} E _{on}	Turn-on Current Slope Turn-on Switching Losses	V _{CC} = 480 V, I _C = 12 A R _G = 10Ω, V _{GE} = 15 V, T _J = 125°C		800 290		A/μs μJ

ELECTRICAL CHARACTERISTICS (CONTINUED)

SWITCHING OFF

Symbol	Parameter	Test Conditions	Min.	Typ.	Max.	Unit	
t_c	Cross-over Time	$V_{CC} = 480\text{ V}$, $I_C = 12\text{ A}$, $R_{GE} = 10\ \Omega$, $V_{GE} = 15\text{ V}$		150		ns	
$t_r(V_{off})$	Off Voltage Rise Time			27		ns	
$t_{d(off)}$	Delay Time			76		ns	
t_f	Fall Time			92		ns	
$E_{off(**)}$	Turn-off Switching Loss				0.21		mJ
E_{ts}	Total Switching Loss				0.49		mJ
t_c	Cross-over Time	$V_{CC} = 480\text{ V}$, $I_C = 12\text{ A}$, $R_{GE} = 10\ \Omega$, $V_{GE} = 15\text{ V}$ $T_j = 125\text{ }^\circ\text{C}$		230		ns	
$t_r(V_{off})$	Off Voltage Rise Time			76		ns	
$t_{d(off)}$	Delay Time			95		ns	
t_f	Fall Time			200		ns	
$E_{off(**)}$	Turn-off Switching Loss				0.45		mJ
E_{ts}	Total Switching Loss				0.74		mJ

COLLECTOR-EMITTER DIODE

Symbol	Parameter	Test Conditions	Min.	Typ.	Max.	Unit	
I_f	Forward Current				12	A	
I_{fm}	Forward Current pulsed				48	A	
V_f	Forward On-Voltage	$I_f = 6\text{ A}$ $I_f = 6\text{ A}$, $T_j = 125\text{ }^\circ\text{C}$		1.3 1.1	1.9	V V	
t_{rr}	Reverse Recovery Time	$I_f = 6\text{ A}$, $V_R = 50\text{ V}$, $T_j = 125\text{ }^\circ\text{C}$, $di/dt = 100\text{ A}/\mu\text{s}$		80		ns	
Q_{rr}	Reverse Recovery Charge				240		nC
I_{rrm}	Reverse Recovery Current				5.5		A

Note: 1. Pulsed: Pulse duration = 300 μs , duty cycle 1.5 %.
 2. Pulse width limited by max. junction temperature.
 (**)Losses include Also the Tail (Jedec Standardization)

Thermal Impedance

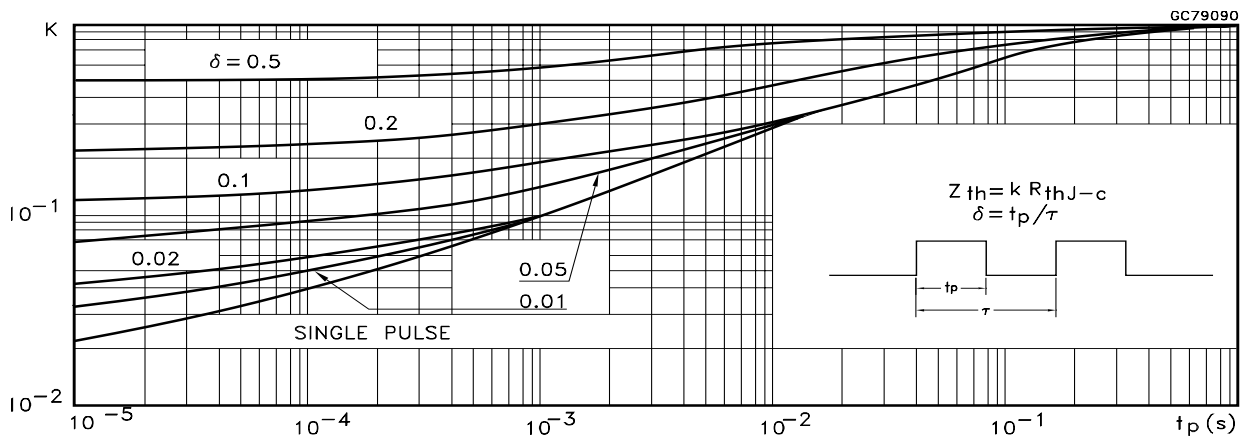

STGP12NB60HD

Output Characteristics

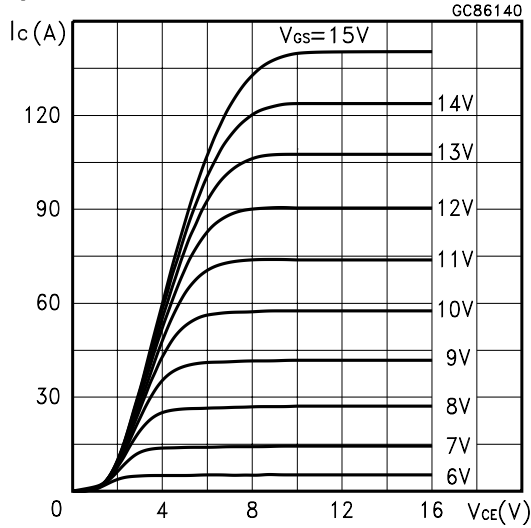

Transfer Characteristics

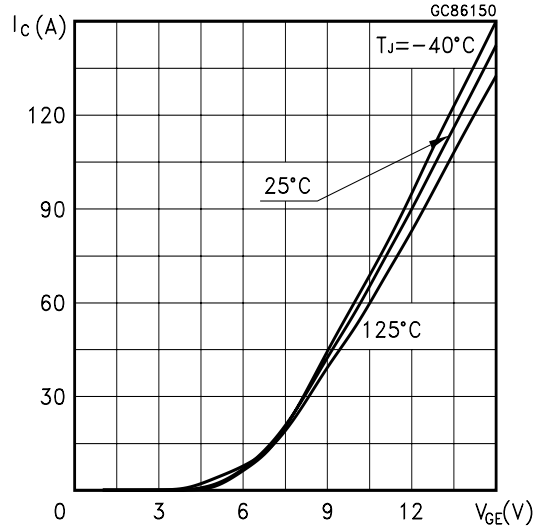

Transconductance

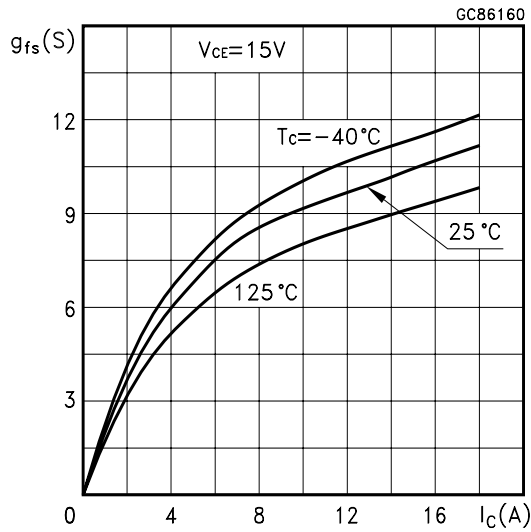

Collector-Emitter On Voltage vs Temperature

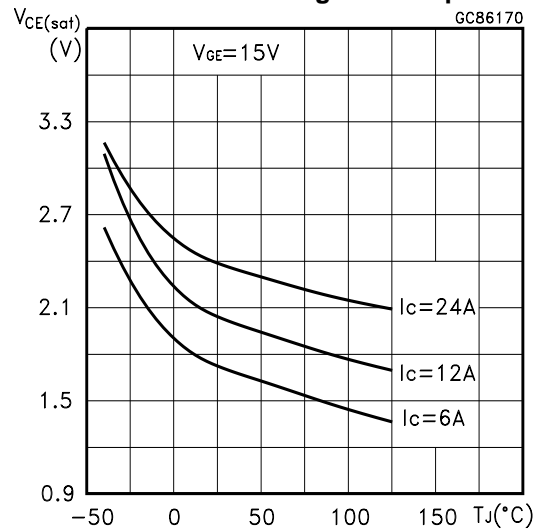

Collector-Emitter On Voltage vs Collector Current

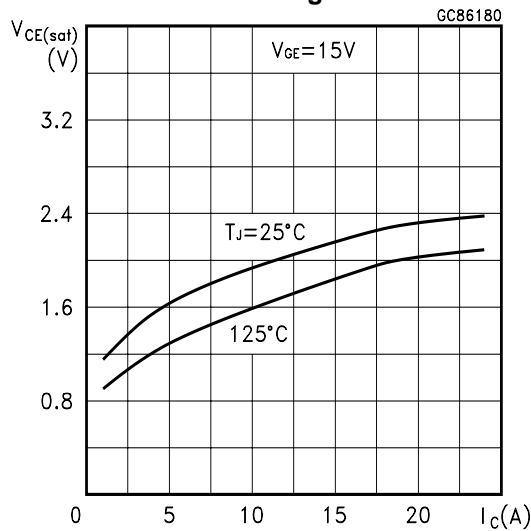

Gate Threshold vs Temperature

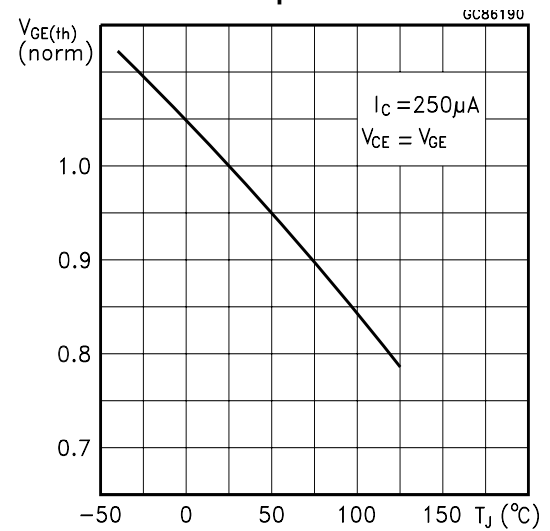

Normalized Breakdown Voltage vs Temperature

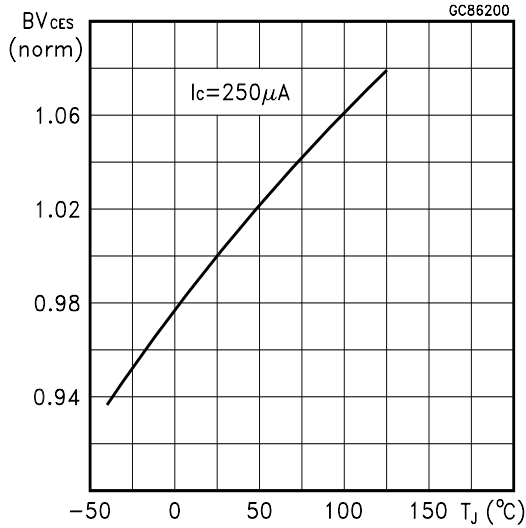

Capacitance Variations

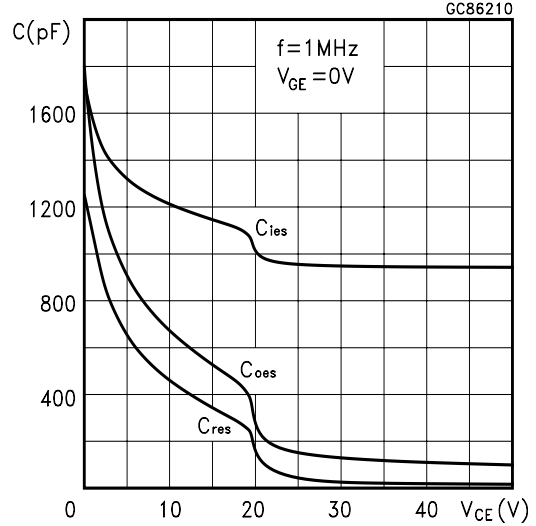

Gate Charge vs Gate-Emitter Voltage

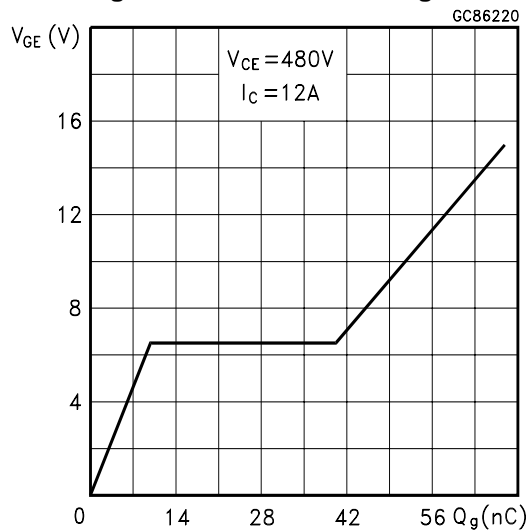

Total Switching Losses vs Gate Resistance

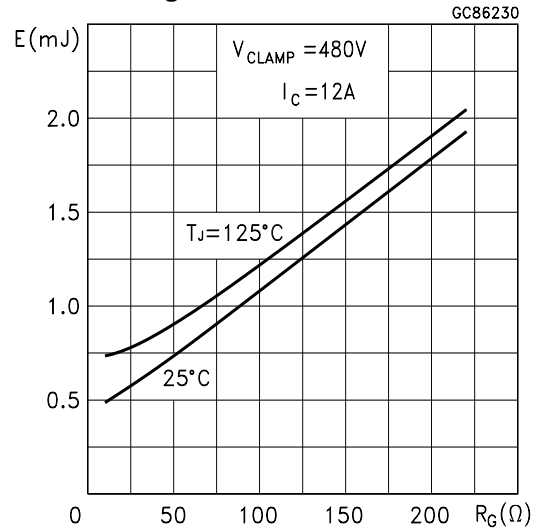

Total Switching Losses vs Temperature

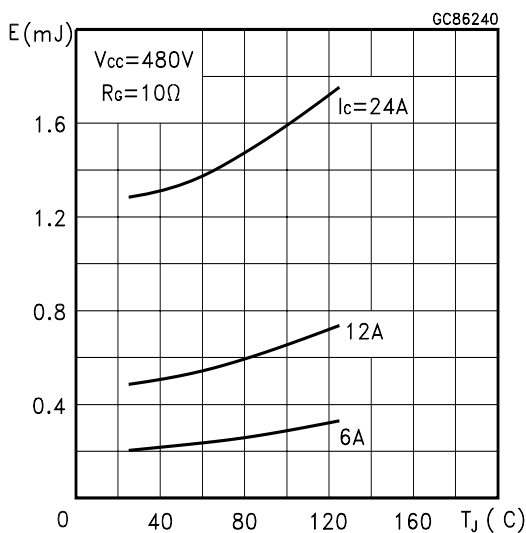

Total Switching Losses vs Collector Current

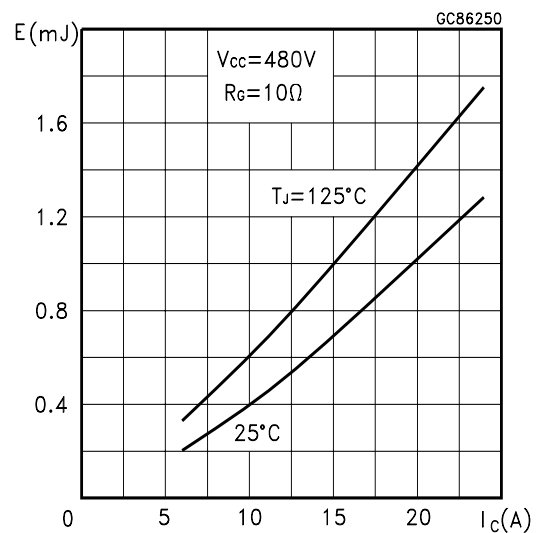

STGP12NB60HD

Switching Off Safe Operating Area

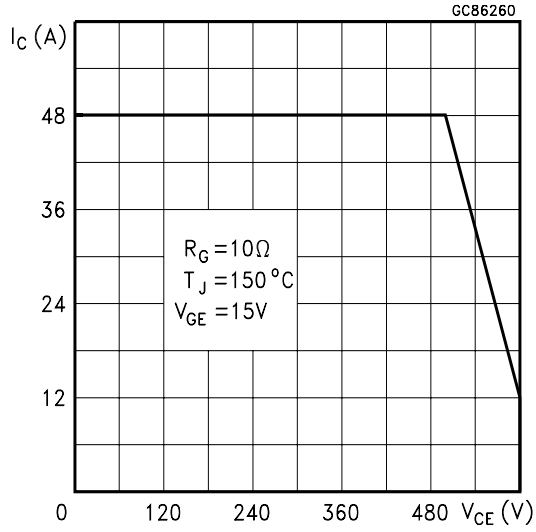

Diode Forward Voltage

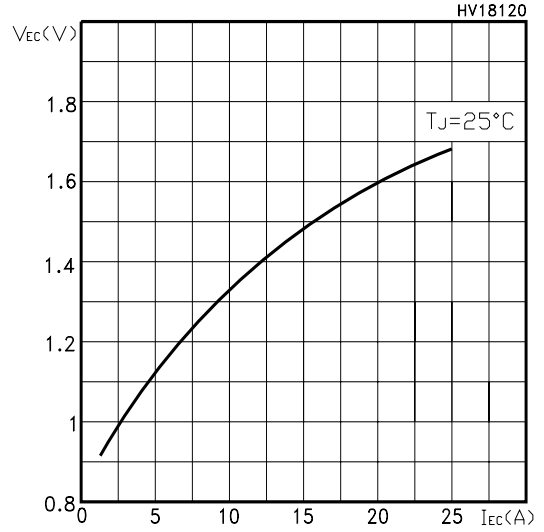

TO-220 MECHANICAL DATA

DIM.	mm.			inch		
	MIN.	TYP.	MAX.	MIN.	TYP.	MAX.
A	4.40		4.60	0.173		0.181
b	0.61		0.88	0.024		0.034
b1	1.15		1.70	0.045		0.066
c	0.49		0.70	0.019		0.027
D	15.25		15.75	0.60		0.620
E	10		10.40	0.393		0.409
e	2.40		2.70	0.094		0.106
e1	4.95		5.15	0.194		0.202
F	1.23		1.32	0.048		0.052
H1	6.20		6.60	0.244		0.256
J1	2.40		2.72	0.094		0.107
L	13		14	0.511		0.551
L1	3.50		3.93	0.137		0.154
L20		16.40			0.645	
L30		28.90			1.137	
øP	3.75		3.85	0.147		0.151
Q	2.65		2.95	0.104		0.116

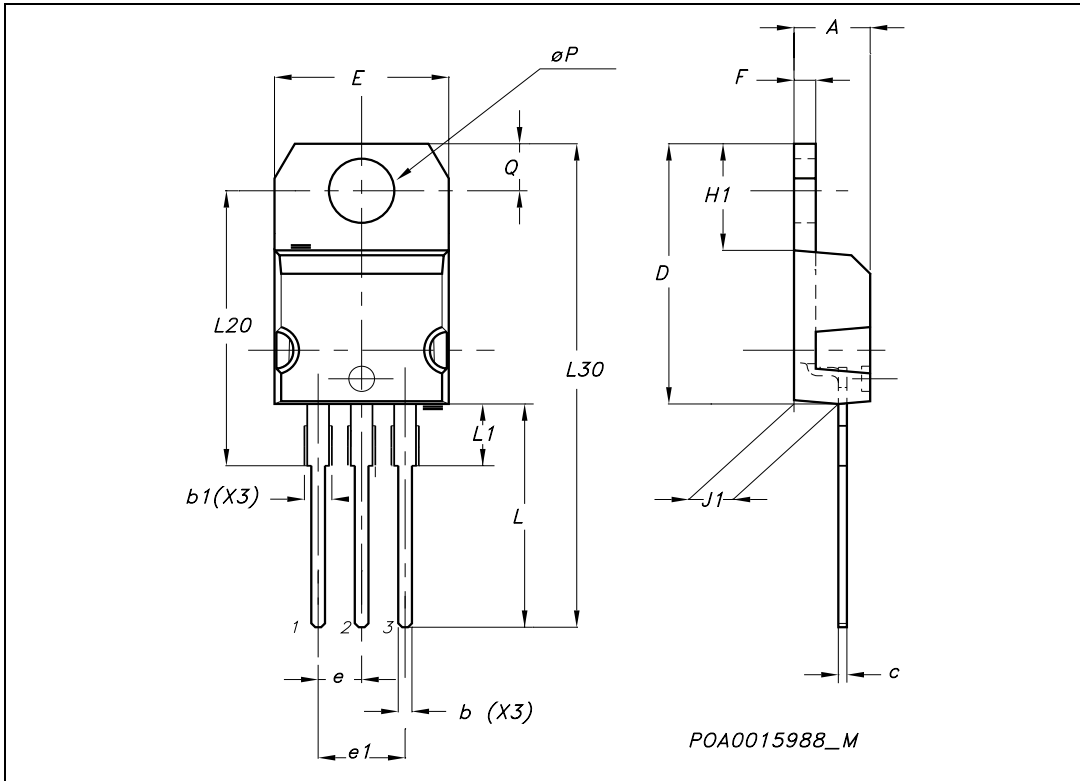

Information furnished is believed to be accurate and reliable. However, STMicroelectronics assumes no responsibility for the consequences of use of such information nor for any infringement of patents or other rights of third parties which may result from its use. No license is granted by implication or otherwise under any patent or patent rights of STMicroelectronics. Specifications mentioned in this publication are subject to change without notice. This publication supersedes and replaces all information previously supplied. STMicroelectronics products are not authorized for use as critical components in life support devices or systems without express written approval of STMicroelectronics.

© The ST logo is a registered trademark of STMicroelectronics

© 2003 STMicroelectronics - Printed in Italy - All Rights Reserved
STMicroelectronics GROUP OF COMPANIES

Australia - Brazil - Canada - China - Finland - France - Germany - Hong Kong - India - Israel - Italy - Japan - Malaysia - Malta - Morocco
Singapore - Spain - Sweden - Switzerland - United Kingdom - United States.

© <http://www.st.com>