



# STLC2500

## BLUETOOTH™ SINGLE CHIP

PRELIMINARY DATA

### 1 FEATURES

- Bluetooth™ specification compliance: V1.1 and V1.2
- Ericsson Licensing Technology Baseband Core (EBC)
- Point-to-point, point-to-multi-point (up to 7 slaves) and scatternet capability
- Asynchronous Connection Oriented (ACL) logical transport link
- Synchronous Connection Oriented (SCO) link: 2 simultaneous SCO channels
- Support Pitch-Period Error Concealment (PPEC)
  - Improves speech quality in the vicinity of interference
  - Improves coexistence with WLAN
  - Works at receiver, no Bluetooth implication
- Adaptive Frequency Hopping (AFH): hopping kernel, channel assessment as Master and as Slave
- Faster Connection: Interlaced scan for Page and Inquiry scan, first FHS without random back off, RSSI used to limit range
- Extended SCO (eSCO) links
- HW support for packet types
  - ACL: DM1, 3, 5 and DH1, 3, 5
  - SCO: HV1, 3 and DV
  - eSCO: EV3, 5
- Clock support
  - System clock input (digital or sine wave) at 13, 26, 19.2 or 38.4 MHz
  - LPO clock input at 3.2, 16.384, 32 or 32.768 kHz
- ARM7TDMI CPU
  - 32-bit Core
  - AMBA (AHB-APB) bus configuration
- Patch RAM capability
- Memory organization
  - On chip RAM, including provision for patches
  - On chip ROM, preloaded with SW up to HCI
- Communication interfaces
  - Fast UART
  - PCM interface
  - 4 programmable GPIOs
  - External interrupts possible through the GPIOs
  - Fast master I2C interface
- Efficient support for WLAN coexistence in collocated scenario
- Ciphering support up to 128 bits key
- Software support
  - Lower level stack (up to HCI)
  - HCI Transport Layer: H4 (including propri-

Figure 1. Package



Table 1. Order Codes

Part Number	Package
STLC2500	TFBGA84

- etary extensions)
  - HCI proprietary commands (e.g. peripherals control)
  - Single HCI command for patch/upgrade download
- Single power supply with internal regulators for core voltage generation
- Supports 1.65 to 2.85 Volts IO systems
- Total number of external components limited to 7 (6 decoupling capacitors and 1 filter) thanks to:
  - Fully integrated synthesizer (VCO and loop filter)
  - Integrated antenna switch
  - Low IF receiver
- Auto calibration (VCO, Filters)
- No need for calibration of the RF part
- Timer and watchdog
- Power class 2 compatible
- Ultra low power architecture with 3 different low power levels:
  - Sleep Mode
  - Deep Sleep Mode
  - Complete Power Down Mode
- Software Initiated Low Power Mode
- Dual Wake-up mechanism: initiated either by the Host or by the Bluetooth device
- Standard TFBGA-84 pins package

### 2 DESCRIPTION

The STLC2500 is a single chip ROM-based Bluetooth solution implemented in 0.13 μm ultra low power, low leakage CMOS technology for applications requiring integration up to HCI level. Patch RAM is available enabling multiple patches/upgrades.

The STLC2500's main interfaces are UART for HCI transport, PCM for voice and GPIOs for control purposes. The Radio is designed for the single chip requirement and for drastic power consumption reduction.



## STLC2500

### 3 QUICK REFERENCE DATA

VDD\_IO\_x means VDD\_IO\_A, VDD\_IO\_B. (See also table 13 subsection Power supply.)

#### 3.1 Absolute Maximum Ratings

The Absolute Maximum Rating (AMR) corresponds to the maximum value that can be applied without leading to instantaneous or very short-term unrecoverable hard failure (destructive breakdown).

**Table 2. Absolute Maximum Ratings**

Symbol	Parameter	Min.	Max.	Unit
VDD_HV	Regulator input supply voltage	$V_{SS} - 0.3$	4.0	V
VDD_IO_x	Supply voltage I/O	$V_{SS} - 0.3$	4.0	V
V <sub>ssdiff</sub>	Maximum voltage difference between different types of V <sub>SS</sub> pins	-0.3	0.3	V
V <sub>in</sub>	Input voltage of any digital pin	$V_{SS} - 0.3$	4.0	V
T <sub>stg</sub>	Storage temperature	-65	+150	°C
T <sub>lead</sub>	Lead temperature <10s		+250	°C

V<sub>SS</sub> can be any VSS\_xxx pin.

#### 3.2 Operating Ranges

Operating ranges define the limits for functional operation and parametric characteristics of the device. Functionality outside these limits is not implied.

**Table 3. Operating ranges**

Symbol	Parameter	Min.	Typ.	Max.	Unit
T <sub>amb</sub>	Operating ambient temperature	-40		+85	°C
VDD_HV	Regulator input supply voltage	2.65 <sup>(*)</sup>	2.75	2.85 <sup>(*)</sup>	V
VDD_IO_A	Supply voltage for I/O	1.65		2.85 <sup>(**)</sup>	V
VDD_IO_B	Supply voltage for I/O	1.35		2.85 <sup>(**)</sup>	V

(\*) The chip will be characterized from 2.62 [V] up to 2.9 [V].

(\*\*) The chip will be characterized up to 2.9 [V].

#### 3.3 I/O specifications

The I/Os comply with the EIA/JEDEC standard JESD8-B.

**Table 4. DC Input specification (all digital I/Os except system clock)**

Symbol	Parameter	Min.	Typ.	Max.	Unit
V <sub>IL</sub>	Low Level input voltage			0.35 * VDD_IO_x	V
V <sub>IH</sub>	High Level input voltage	0.65 * VDD_IO_x			V
V <sub>hyst</sub>	Schmitt trigger hysteresis	0.4	0.5	0.6	V

**Table 5. DC Output specification**

Symbol	Parameter	Condition	Min.	Typ.	Max.	Unit
V <sub>OL</sub>	Low Level output voltage	I <sub>d</sub> = X mA			0.15	V
V <sub>OH</sub>	High Level output voltage	I <sub>d</sub> = X mA	VDD_IO_x - 0.15			V

Note: X is the source/sink current under worst-case conditions according to the drive capabilities (see section 5)

### 3.4 Clock specifications

The STLC2500 supports, on the same input pin, the system clock both as a sine wave clock and as a digital clock (see table 15 for selection). The system clock section is powered by VDD\_CLD (G08 and H09). The voltage range for VDD\_CLD is the same as for VDD\_IO\_A.

**Table 6. System clock supported frequencies**

Symbol	Parameter	Values	Unit
F <sub>IN</sub>	Clock input frequency list	13, 26, 19.2, 38.4	MHz

**Table 7. System clock overall specifications**

Symbol	Parameter	Min.	Typ.	Max.	Unit
F <sub>INTOL</sub>	Tolerance on input frequency	-20		20	ppm

**Table 8. System clock, sine wave specifications**

Symbol	Parameter	Min.	Typ.	Max.	Unit
V <sub>PP</sub>	Peak to peak voltage range	0.2	0.5	1	V
N <sub>H</sub>	Total harmonic content of input signal			-25	dBc
Z <sub>INRe</sub>	Real part of parallel input impedance at pin	30	60	90	KΩ

**Table 9. System clock, digital clock DC specifications**

Symbol	Parameter	Min.	Typ.	Max.	Unit
V <sub>IL</sub>	Low Level input voltage			0.22 * VDD_IO_A	V
V <sub>IH</sub>	High Level input voltage	0.85 * VDD_IO_A			V

**Table 10. System clock, digital clock AC specifications**

Symbol	Parameter	Min.	Typ.	Max.	Unit
T <sub>RISE</sub>	10%-90% rise time		1,5	6	ns
T <sub>FALL</sub>	90%-10% fall time		1,5	6	ns
D <sub>CYCLE</sub>	Duty Cycle	45	50	55	%

**Table 11. Low Power clock specifications**

The low power clock pin is powered by connecting VDD\_IO\_B to the wanted supply.

Symbol	Parameter	Min.	Typ.	Max.	Unit
	Duty Cycle	30		70	%
	Accuracy			±250	ppm

# STLC2500

## 3.5 Current Consumption

**Table 12. Typical current consumption** ( $T_{amb} = 25^{\circ}\text{C}$ , 26 MHz digital clock, 1.8 Volts at I/Os)

STLC2500 state	Value	Unit
Complete Power Down	6	$\mu\text{A}$
Deep Sleep Mode	25	$\mu\text{A}$
Sleep Mode	1.4	mA
Page/Inquiry scan (1,28 seconds period), combined with Deep Sleep Mode	0.4	mA
Active: audio (HV3)	10.9	mA
Active: data (DH1) (172,8 Kbps symmetrical)	21.8	mA
Active: audio eSCO (EV3), (64 Kbps symmetrical TSCO=6)	11.3	mA
Active: audio eSCO (EV5), (64 Kbps symmetrical TSCO=12)	9.6	mA
Active: audio eSCO (EV5), (64 Kbps symmetrical TSCO=18)	9.1	mA
Active: audio eSCO (EV5), (64 Kbps symmetrical TSCO=24)	8.9	mA
Active: audio eSCO (EV5), (64 Kbps symmetrical TSCO=36)	8.5	mA
Continuous RX, RF sub chip only.	34	mA
Continuous TX, RF sub chip only at 2.5 dBm output power.	32	mA

## 4 BLOCK DIAGRAM AND ELECTRICAL SCHEMA

**Figure 2. The complete chip**

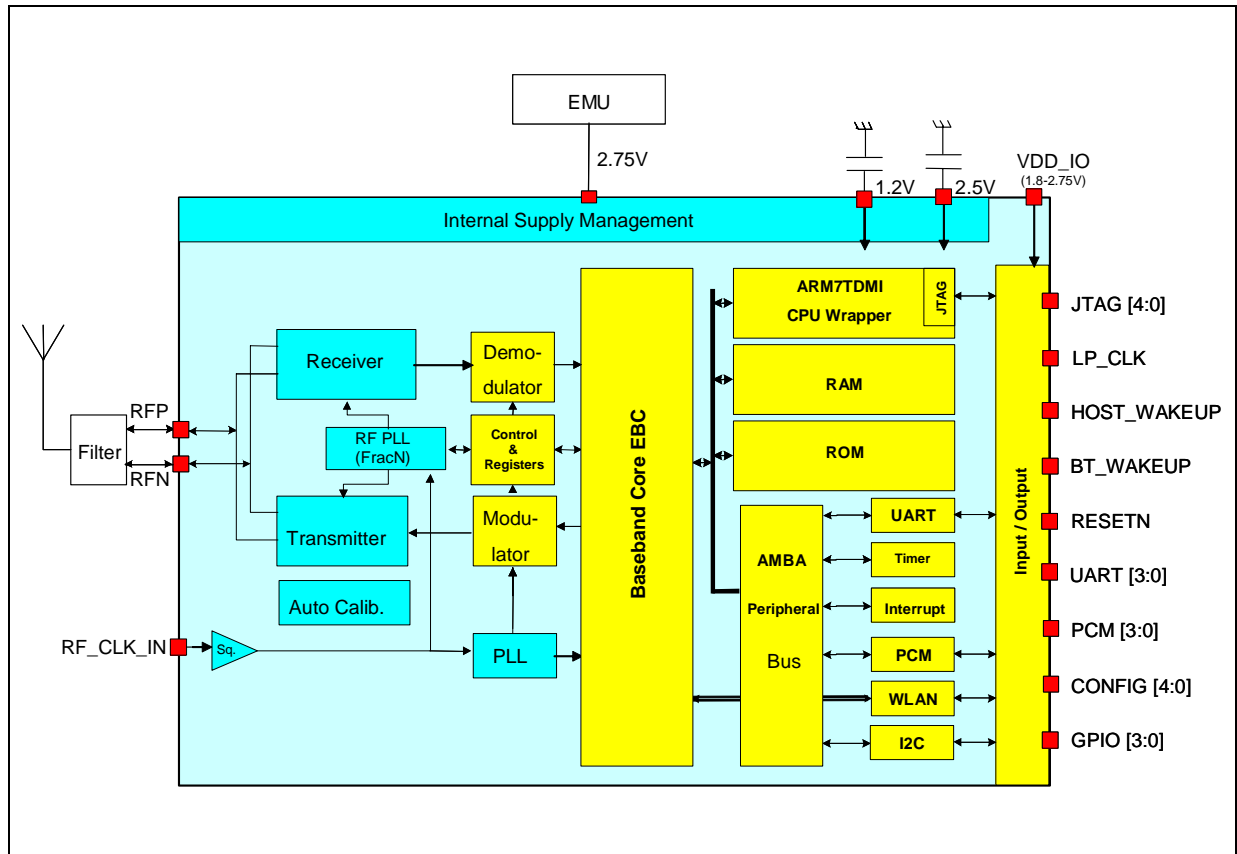

## 5 PINOUT

### 5.1 Pin out bottom view

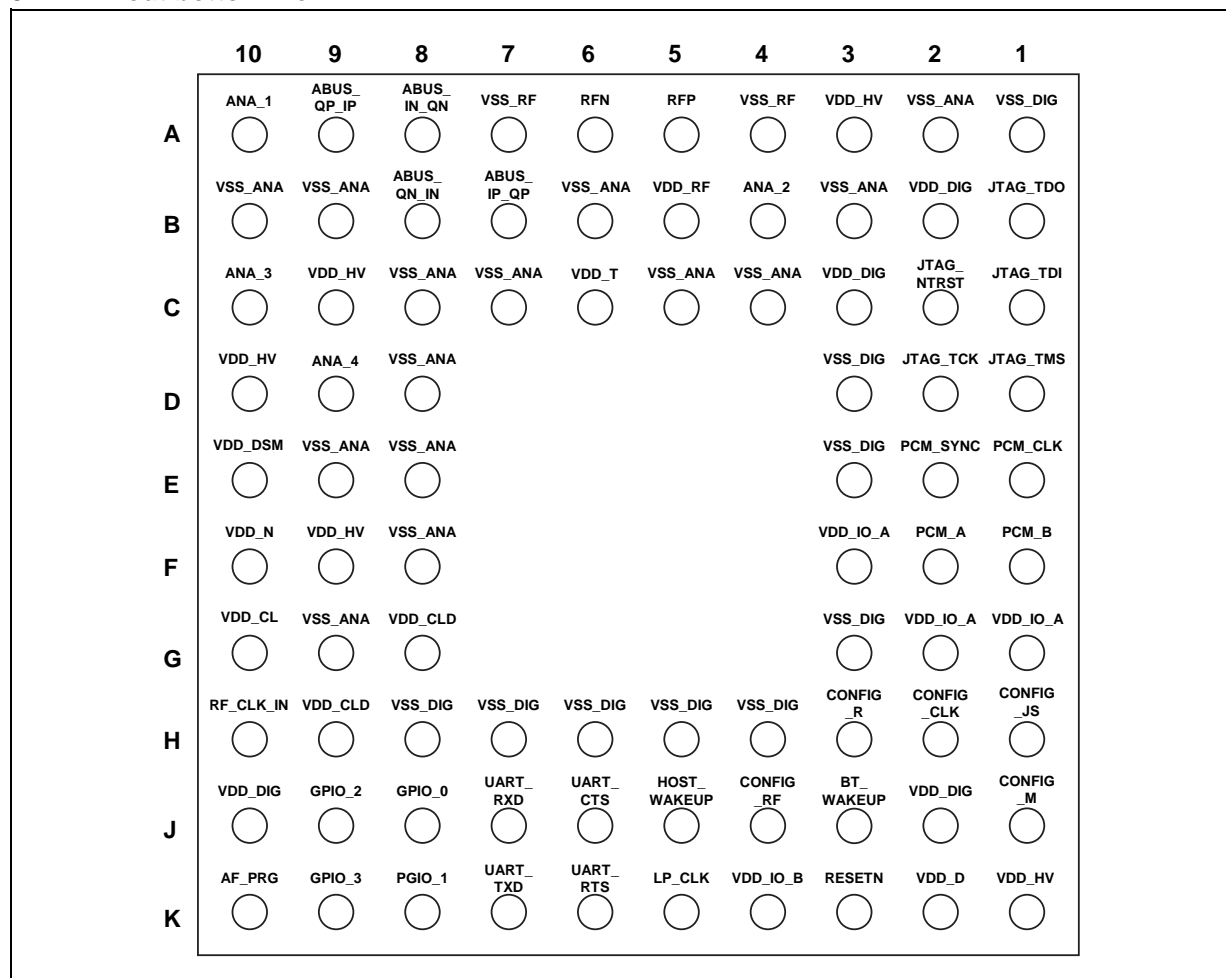

### 5.2 Pin Description and Assignment

Table 13 shows the pin list of the STLC2500. The column "PU/PD" shows the pads implementing a pull-down/up. The column "DIR" describes the pin directions:

- I for Inputs
- O for Outputs
- I/O for Input/Output
- O/t for tri-state outputs

The column Reset and Default show the state of the pins in reset and the default value after reset. For the output pin the default drive capability is 2 mA.

**Table 13. STLC2500 pin list (Functional and Supply)**

Name	Pin #	Description	DIR	Reset	Default after reset	VDD_IO_x
<b>Clock and Reset pins</b>						
RESETN	K03	Global reset - active low	I	Input	Input	A
RF_CLK_IN	H10	Reference clock input	I	Input	Input	(3)
LP_CLK	K05	Low power clock input	I	Input	Input	B

## STLC2500

Table 13. STLC2500 pin list (Functional and Supply) - continued

Name	Pin #	Description	DIR	Reset	Default after reset	VDD_IO_x
<b>SW initiated Low Power mode</b>						
HOST_WAKEUP	J05	Wake-up signal to host	I/O	Input PD	Output high	B
BT_WAKEUP	J03	Wake-up signal to Bluetooth	I	Input <sup>(2)</sup>	Input	A
<b>UART interface</b>						
UART_RXD	J07	UART receive data	I	Input PD	Input	A
UART_TXD	K07	UART transmit data	O/t (I/O)	Tri-state PD	Output high	A
UART_CTS	J06	UART clear to send	I	Input PU <sup>(2)</sup>	Input	A
UART_RTS	K06	UART Request to send	O/t (I/O)	Tri-state PU	Output low	A
<b>PCM interface</b>						
PCM_SYNC	E02	PCM frame signal	I/O	Input PD	Input PD	A
PCM_CLK	E01	PCM clock signal	I/O	Input PD	Input PD	A
PCM_A	F02	PCM data	I/O	Input PD	Input PD	A
PCM_B	F01	PCM data	I/O	Input PD	Input PD	A
<b>JTAG interface</b>						
JTAG_TDI	C01	JTAG data input	I	Input PU	Input PU	A
JTAG_TDO	B01	JTAG data output	O/t	Tri-state PD	Tri-state	A
JTAG_TMS	D01	JTAG mode signal	I	Input PU	Input PU	A
JTAG_NTRST	C02	JTAG reset active low	I	Input PD	Input PD	A
JTAG_TCK	D02	JTAG clock input	I	Input <sup>(1)</sup>	Input	A
<b>General purpose Input/Output pins</b>						
GPIO_0	J08	General purpose IO	I/O	Input PD	Input PD	A
GPIO_1	K08	General purpose IO	I/O	Input PD	Input PD	A
GPIO_2	J09	General purpose IO	I/O	Input PD	Input PD	A
GPIO_3	K09	General purpose IO	I/O	Input PD	Input PD	A
<b>Configuration pins</b>						
CONFIG_JS	H01	Configuration signal	I	Input	Input	A
CONFIG_CLK	H02	Configuration signal	I	Input	Input	A
CONFIG_R	H03	Configuration signal	I	Input	Input	A
CONFIG_M	J01	Configuration signal	I	Input	Input	A
CONFIG_RF	J04	Configuration signal	I	Input	Input	A
<b>RF signals</b>						
RFP	A05	Differential RF port	I/O			
RFN	A06		I/O			
<b>Power supply</b>						
VDD_HV	A03	Power supply (Connect all to 2.75V)				
	C09					
	D10					
	F09					
	K01					
VDD_D	K02	Output regulator for core logic				

Table 13. STLC2500 pin list (Functional and Supply) - continued

Name	Pin #	Description	DIR	Reset	Default after reset	VDD_IO_x
VDD_DIG	B02	Core logic supply (Connect all to VDD_D)				
	C03					
	J02					
	J10					
VDD_IO_A	F03	1.65V to 2.85V I/Os supply (Connect all)				
	G02					
	G01					
VDD_IO_B	K04	1.35V to 2.85V I/Os supply				
VDD_CLD	G08	System clock supply 1.65V to 2.85V (Connect all to VDD_IO_A in case of a digital reference clock input, to VSS_ANA in case of an analogue reference clock input)				
	H09					
VDD_DSM	E10	Internal supply decoupling				
VDD_N	F10	Internal supply decoupling				
VDD_CL	G10	Internal supply decoupling				
VDD_RF	B05	Internal supply decoupling				
VSS_DIG	A01	Digital ground				
	D03					
	E03					
	G03					
	H04					
	H05					
	H06					
	H07					
VSS_ANA	A02	Analogue ground				
	B03					
	B06					
	B09					
	B10					
	C04					
	C05					
	C07					
	C08					
	D08					
	E08					
	E09					
VSS_RF	A04	RF ground				
	A07					

- (1) Should be strapped to VSS\_DIG if not used  
(2) Should be strapped to VDD\_IO\_A if not used  
(3) See also pin VDD\_CLD in table 13

## STLC2500

**Table 14. STLC2500 pin list (Test)**

Name	PIN #	Description	DIR	Reset	Default	VDDIO
<b>Analogue test pin</b>						
VDD_T	C06	Test supply				
ABUS_IN_QN	A08	Test pin	I/O	Input (1)	Input (1)	
ABUS_QP_IP	A09	Test pin	I/O	Input (1)	Input (1)	
ABUS_IP_QP	B07	Test pin	I/O	Input (1)	Input (1)	
ABUS_QN_IN	B08	Test pin	I/O	Input (1)	Input (1)	
ANA_1	A10	Analogue test pin (Leave unconnected)				
ANA_2	B04	Analogue test pin (Leave unconnected)				
ANA_3	C10	Analogue test pin (Leave unconnected)				
ANA_4	D09	Analogue test pin (Leave unconnected)				
AF_PRG	K10	Test pin (Leave unconnected)	I/O	Open	Open	

(1) To be strapped to VSS\_ANA

**Table 15. STLC2500 pin list (Configuration)**

The configuration pins are used to select different modes of operation for the chip:

<b>Digital or analogue incoming system clock</b>	
CONFIG_CLK = '1'	The incoming system clock is a digital square signal. (See chapter 3.4.)
CONFIG_CLK = '0'	The incoming system clock is a sine wave signal. (See chapter 3.4.)
<b>Initiated Low Power modes</b>	
CONFIG_JS = '0' AND CONFIG_M = '0'	Reserved
CONFIG_JS = '0' AND CONFIG_M = '1'	Initiated low power, mode 1. (See chapter 7.8.)
CONFIG_JS = '1' AND CONFIG_M = '0'	Initiated low power, mode 2. (See chapter 7.8.)
CONFIG_JS = '1' AND CONFIG_M = '1'	Reserved

Where '1' means VDD\_IO\_A and '0' means VSS\_DIG.

The other two configuration pins, CONFIG\_RF and CONFIG\_R have to be strapped to VSS\_DIG.

## 6 FUNCTIONAL DESCRIPTION

### 6.1 Transmitter

The transmitter uses the serial transmit data from the baseband. The transmitter modulator converts this data into GFSK modulated I and Q digital signals. These signals are then converted to analogue signals that are low pass filtered before up-conversion. The carrier frequency drift is limited by a closed loop PLL.

### 6.2 Receiver

The STLC2500 implements a low-IF receiver for Bluetooth modulated input signals. The radio signal is taken from a balanced RF input and amplified by an LNA. The mixers are driven by two quadrature LO signals, which are locally generated from a VCO signal running at twice the frequency. The I and Q mixer output signals are band pass filtered by a poly-phase filter for channel filtering and image rejection. The



output of the band pass filter is amplified by a VGA to the optimal input range for the A/D converter. Further channel filtering is done in the digital part. The digital part demodulates the GFSK coded bit stream by evaluating the phase information in the digital I and Q signals. RSSI data is extracted. Overall automatic gain amplification in the receive path is controlled digitally. The RC time constants for the analogue filters are automatically calibrated on chip.

### 6.3 PLL

The on-chip VCO is part of a PLL. The tank resonator circuitry for the VCO is completely integrated without need of external components. Variations in the VCO centre frequency are calibrated out automatically.

### 6.4 Baseband 1.1 Features

The baseband is based on Ericsson Licensing Technology Baseband Core (EBC) and it is compliant with the Bluetooth specification 1.1:

- Point to multipoint (up to 7 Slaves)
- Asynchronous Connection Less (ACL) link support giving data rates up to 721 kbps
- Synchronous Connection Oriented (SCO) link with support for 2 voice channels over the air interface
- Flexible voice format to Host and over the air (CVSD, PCM 13/16 bits, A-law,  $\mu$ -law)
- HW support for packet types: DM1, 3, 5; DH1, 3, 5; HV1, 3; DV
- Scatternet capabilities (Master in one piconet and Slave in the other one; Slave in two piconets). All scatternet v.1.1 errata supported
- Ciphering support up to 128 bits key
- Paging modes R0, R1, R2
- Channel Quality Driven Data Rate
- Full Bluetooth software stack available
- Low-level link controller

### 6.5 Baseband 1.2 Features

The baseband part is also compliant with the Bluetooth specification 1.2:

- Adaptive Frequency Hopping (AFH): hopping kernel, channel assessment as Master and as Slave
- Faster Connection: Interlaced scan for Page and Inquiry scan, answer FHS at first reception, RSSI used to limit range
- Extended SCO (eSCO) links: supports EV3 and EV5 packets
- QoS Flush
- Synchronization: BT clocks are available at HCI level for synchronization of parallel applications on different Slaves
- L2CAP Flow & Error control
- LMP improvements
- LMP SCO handling
- Parameter Ranges update

#### 6.5.1 V1.2 detailed functionality - Extended SCO

##### User Perspective - Extended SCO

This function gives improved voice quality since it enables the possibility to retransmit lost or corrupted voice packets in both directions.

##### Technical perspective - Extended SCO

eSCO incorporates CRC, negotiable data rate, negotiable retransmission window and multi-slot packets. Retransmission of lost or corrupted packets during the retransmission window guarantees on-time delivery.

Figure 3. eSCO

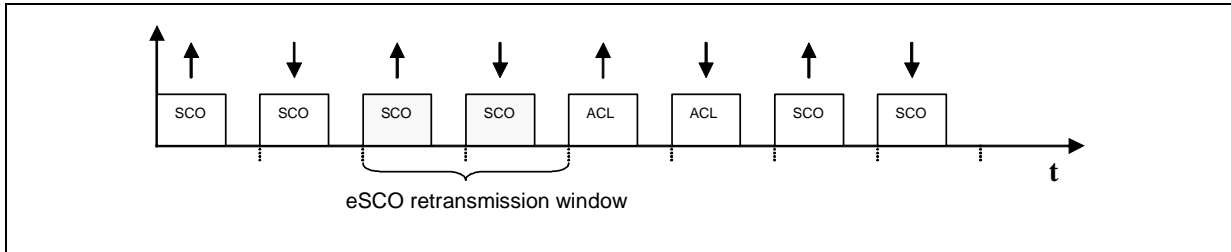

6.5.2 V1.2 detailed functionality - Adaptive Frequency Hopping

User Perspective - Adaptive Frequency Hopping

In the Bluetooth spec 1.1, the Bluetooth devices hop in the 2.4 GHz band over 79-channels. As WLAN 802.11 has become popular, there are improvements in the Bluetooth spec 1.2 specifying how Bluetooth units can avoid jammed bands and provide an improved co-existence with WLAN.

Technical perspective - Adaptive Frequency Hopping

Figure 4. AFH

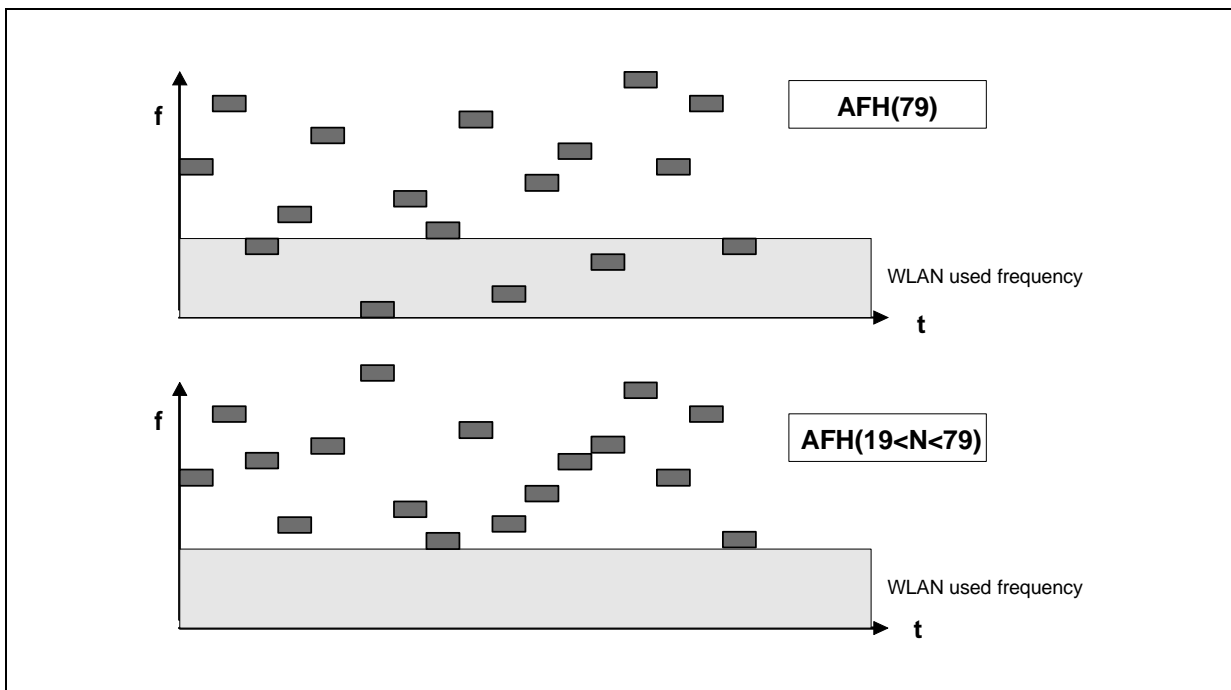

First the Master and/or the Slaves identify the jammed channels. The Master decides on the channel distribution and informs the involved slaves. The Master and the Slaves, at a predefined instant, switch to the new channel distribution scheme.

No longer jammed channels are re-inserted into the channel distribution scheme. AFH uses the same hop frequency for transmission as for reception.

6.5.3 V1.2 detailed functionality - Faster Connection

User Perspective - Faster Connection

This feature gives the User about 65% faster connection on average when enabled compared to Bluetooth spec 1.1 connection procedure.

### Technical perspective - Faster Connection

The Faster Inquiry functionality is based on a removed/shortened random back off and also a new Interlaced Inquiry Scan scheme.

The Faster Page functionality is based on Interlaced Page Scan.

### 6.5.4 V1.2 detailed functionality - Quality of Service

#### User Perspective - Quality of Service

Small changes to the BT1.1 spec regarding Quality of Service make a large difference.

Allowing all QoS parameters to be communicated over HCI to the link manager enables efficient bandwidth management. Here after a short list of user perspectives:

- 1) Flush timeout: enables time-bounded traffic such as video streaming to become more robust when the channel degrades. It sets the maximum delay of an L2CAP frame. It does not enable multiple streams in one piconet, or heavy data transfer at the same time.
- 2) Simple latency control: allows the Host to set the poll interval. This provides support for HID devices mixed with other traffic in the piconet.

### 6.6 Processor and memory

- ARM7TDMI
- On chip RAM, including provision for patches
- On chip ROM, preloaded with SW up to HCI

## 7 GENERAL SPECIFICATION

All the provided values are specified over the operational conditions (VDD and temperature) according to the Bluetooth 1.1 and 1.2 specifications unless otherwise specified.

### 7.1 Receiver

To be compliant with the Bluetooth norm, an external RF filter is required to provide minimum -17dB of attenuation in the band: 30MHz - 2000MHz and 3000MHz - 12.75GHz. All specifications below are given at pin level and over temperature unless otherwise specified.

**Table 16. Receiver Parameters** ( $T_{amb} = 25^{\circ}\text{C}$ ,  $VDD_{HV} = 2.75\text{V}$ , parameters are given at device pin.)

Symbol	Parameter	Test Condition	Min.	Typ.	Max.	Unit
RFin	Input frequency range		2402		2480	MHz
RXsens	Receiver Sensitivity (Clean transmitter)	@ BER 0.1%		-85		dBm
RXmax	Maximum useable input signal level	@ BER 0.1%		+15		dBm
<b>Receiver interferer performance @BER 0.1%</b>						
C/I <sub>co-channel</sub>	Co-channel interference	@ Input signal strength = -60dBm			9	dB
C/I <sub>1MHz</sub>	Adjacent ( $\pm 1\text{MHz}$ ) interference	@ Input signal strength = -60dBm			-2	dB
C/I <sub>+2MHz</sub>	Adjacent (+2MHz) interference	@ Input signal strength = -60dBm		-35		dB
C/I <sub>-2MHz</sub>	Adjacent (-2MHz) interference	@ Input signal strength = -67dBm		-25		dB

## STLC2500

**Table 16. Receiver Parameters** ( $T_{amb} = 25^{\circ}\text{C}$ ,  $VDD_{HV} = 2.75\text{V}$ , parameters are given at device pin.)

Symbol	Parameter	Test Condition	Min.	Typ.	Max.	Unit
C/I <sub>+3MHz</sub>	Adjacent (+3MHz) interference	@ Input signal strength = -67dBm		-44		dB
C/I <sub>-3MHz</sub>	Adjacent (-3MHz) interference	@ Input signal strength = -67dBm		-37		dB
C/I <sub>≥4MHz</sub>	Adjacent (≥±4MHz) interference	@ Input signal strength = -67dBm		-46		dB
<b>Receiver inter-modulation</b>						
IMD	Inter-modulation	Measured as defined in BT test specification.		-35		dBm

### 7.2 Transmitter

All output power specifications are given at the pin level and over temperature range unless otherwise specified.

**Table 17. Transmitter Parameters** ( $T_{amb} = 25^{\circ}\text{C}$ ,  $VDD_{HV} = 2.75\text{V}$ , parameters are given at device pin.)

Symbol	Parameter	Test Condition	Min.	Typ.	Max.	Unit
RFout	Output frequency range		2402		2480	MHz
TXpout	Nominal Output power	@2402-2480 MHz	0	3	5	dBm
<b>In-band spurious emission</b>						
FCC	FCC's 20 dB BW			932		kHz
TX_SE2	Channel offset=2			-51		dBm
TX_SE3	Channel offset=3			-55		dBm
TX_SE4	Channel offset≥4 (except 13)			-57		dBm
<b>Initial carrier frequency tolerance</b> (for an exact reference)						
ΔF	f <sub>TX</sub> -f <sub>0</sub>		-75		75	kHz
<b>Carrier Frequency Drift</b>						
Δf <sub>p1</sub>	One slot packet				25	kHz
Δf <sub>p3</sub>	Three slots packet				40	kHz
Δf <sub>p5</sub>	Five slots packet				40	kHz
<b>Carrier Frequency Drift rate</b>						
Δf/50us	Frequency drift rate				20	kHz/μs

### 7.3 System clock

The STLC2500 works with a single clock (sine wave or digital) provided on the RF\_CLK\_IN pin. Precision of this clock should be 20 ppm. The external STLC2500 clock could be 13 or 26 MHz (for GSM application), 19.2 MHz and 38.4 MHz (for 2.5 & 3G & CDMA platforms).

### 7.4 Low power clock

The low power clock is used by the baseband part as reference clock during the low power modes. It requires an accuracy of 250ppm. The external STLC2500 clock, provided on the LP\_CLK digital pin could be 3.2 kHz, 16.384 kHz, 32 kHz and 32.768 kHz.

The low power clock must be available at all times.

### 7.5 Clock detection

The system and low power clocks can be either selected by specific HCI command or by integrated automatic detection algorithm. The clock detection routine steps are:

- Identification of the system clock frequency (13 MHz, 26MHz, 19.2 MHz or 38.4 MHz)
- Identification of the low power clock (3.2 KHz, 16.384 KHz, 32 KHz or 32.768 KHz)

Remark: The STLC2500 assumes that the low power clock is available at all times.

## 7.6 Interrupts

The user can program the GPIOs as external interrupt sources.

## 7.7 Low power modes

To save power, three low power modes are supported.

Depending of the Bluetooth and of the Host's activity, the STLC2500 autonomously decides to use Deep Sleep Mode, Sleep Mode or active mode.

Complete Power Down is entered only after an explicit command from the Host.

**Table 18. Low power modes**

Low power mode	Description
<b>Sleep Mode</b>	The STLC2500: <ul style="list-style-type: none"> <li>- Accepts HCI commands from the Host.</li> <li>- Supports all types of Bluetooth links.</li> <li>- Can transfer data over Bluetooth links.</li> <li>- Dynamically switches between sleep and active mode when needed.</li> <li>- The system clock is still active in part of the design.</li> <li>- Parts of the chip can be dynamically powered off depending on the Bluetooth activity.</li> </ul>
<b>Deep Sleep Mode</b>	The STLC2500: <ul style="list-style-type: none"> <li>- Does not accept HCI commands from the Host.</li> <li>- Supports page- and inquiry scans.</li> <li>- Supports Bluetooth links that are in Sniff, Hold or Park.</li> <li>- Does not transfer data over Bluetooth links.</li> <li>- Dynamically switches between deep sleep and active mode during Bluetooth activity.</li> <li>- The system clock is not active in any part of the design.</li> <li>- Parts of the chip can be dynamically powered off depending on the Bluetooth activity.</li> </ul>
<b>Complete Power Down</b>	The STLC2500 is effectively powered down: <ul style="list-style-type: none"> <li>- No Bluetooth activity is supported.</li> <li>- The HCI interface is shut down.</li> <li>- The system clock is not active in any part of the design.</li> <li>- Most parts of the chip are completely powered off.</li> <li>- RAM content is not maintained (initialisation is required at wakeup).</li> </ul>

Some examples for the usage of the low power modes:

### 7.7.1 SNIFF OR PARK

The STLC2500 is in active mode with a Bluetooth connection, once the connection is concluded, SNIFF or PARK is programmed. Once one of these two states is entered, the STLC2500 goes into Sleep Mode. After that, the Host may decide to place the STLC2500 in Deep Sleep Mode by putting the UART LINK in low power mode. The Deep Sleep Mode allows for lower power consumption. When the STLC2500 needs to send or receive a packet (e.g. at TSNIFF or at the beacon instant), it requires the clock and it goes into active mode for the needed transmission/reception. Immediately afterwards, it will go back to Deep Sleep Mode. If some HCI transmission is needed, the UART link will be reactivated, using one of the two ways explained in 7.8, and the STLC2500 will move from Deep Sleep Mode to Sleep Mode.

### 7.7.2 INQUIRY/PAGE SCAN

When only inquiry scan or page scan is enabled, the STLC2500 will go in Sleep Mode or Deep Sleep Mode outside the receiver activity. The selection between Sleep Mode and Deep Sleep Mode depends on the UART activity like in SNIFF or PARK.

### 7.7.3 NO CONNECTION

If the Host places the UART in low power and there is no activity, then the STLC2500 can be placed in Deep Sleep Mode. In this mode (no connection), the Host can also decide to put the STLC2500 in Complete Power Down to further reduce the power consumption. In this case some part of the STLC2500 will be completely powered off. It's possible to exit the Complete Power Down by using one of the two methods explained in 7.8. The request to quit the Complete Power Down may be done with an HW reset or it may come from the Host.

### 7.7.4 ACTIVE LINK

When there is an active link (SCO or ACL), the STLC2500 can go neither in Deep Sleep Mode nor in Complete Power Down whatever the UART state is. But the STLC2500 baseband is made such that whenever it is possible, depending on the scheduled activity (number of link, type of link, amount of data exchanged), it goes in Sleep Mode.

## 7.8 SW initiated low power mode

During periods of no activity either on the Bluetooth or on the Host side, the chip can be placed in low power mode. Two modes to initiate low power mode and to wake up are supported (selection is done through pin configuration, see table 15):

- 1 **[Initiated Low power, mode 1]** It requires HOST\_WAKEUP, UART\_RXD (connected with BT\_WAKEUP, the two paths will be physically connected on the board) and UART\_RTS. The UART\_RXD is used as wakeup signal from the host, the HOST\_WAKEUP requires the clock from the Host and the UART\_RTS indicates when the controller is available. In this mode, the break function (UART\_RXD is low for more than 1 word) is used to distinguish between normal operation and low power mode usage.

The system goes in low power mode in this way: the Host tells the Bluetooth device that it can go in low power by forcing the UART\_RXD of the Bluetooth device to '0' for more than 1 word. Then, the device can decide whether to go in low power mode or not depending on its scheduled activity. In case it decides to go in low power mode, it signals it by forcing UART\_RTS high; then it asserts HOST\_WAKEUP low to tell the Host that it does not need the clock anymore. The Bluetooth baseband cannot go in sleep mode by itself. This is a logical consequence of the fact that the system clock is needed to receive characters on the UART and only the Host can stop the UART link.

- The system wakes up in this way: the Bluetooth baseband first asks the Host to restart the system clock by setting HOST\_WAKEUP to '1'. When the clock is available, the device sets UART\_RTS low, and then the Host can give confirmation by releasing the UART\_RXD of the device. In case the Host wants to wake up the chip, it sets the UART\_RXD pin of the Bluetooth device to '1'. The device then confirms it is awake by releasing UART\_RTS to '0'.

- 2 **[Initiated Low power, mode 2]** It requires HOST\_WAKEUP, BT\_WAKEUP, UART\_RTS and UART\_CTS. The wakeup is always initiated by HOST\_WAKEUP or BT\_WAKEUP signal (the peer acknowledges the request). UART\_RTS and UART\_CTS are placed at the value for which they block the UART communication.

- The system goes in low power in this way: the Host sets BT\_WAKEUP to '0', telling the Bluetooth device that it can go in low power. The device can decide whether to go in low power mode or not depending on its scheduled activity. If it decides to go in low power it first asserts UART\_RTS pin to '1' and then it sets HOST\_WAKEUP to '0' to tell the Host that it does not need the system clock anymore. The Host confirms by setting UART\_CTS to '1' and by stopping the clock.

- The system wakes up in this way: the Bluetooth device sets HOST\_WAKEUP to '1' to tell the Host that it needs the clock. The Host delivers the clock, when the device is ready it releases UART\_RTS to '0'. Then the Host confirms by asserting BT\_WAKEUP to '1' and by releasing UART\_CTS to '1'. If the Host wakes up first, it tells it to the Bluetooth device by setting BT\_WAKEUP to '1'. The Bluetooth device sets HOST\_WAKEUP to '1' and then UART\_RTS and UART\_CTS are released by device and Host respectively to tell they are ready to start communicating.

## 7.9 Patch RAM

The STLC2500 includes a HW block that allows patching of the ROM code.

Additionally, a SW patch mechanism allows replacing complete SW functions without changing the ROM image.

A part of the RAM memory is used for HW and SW patches.

## 7.10 Download of SW parameters

To change the device configuration a set of customizable parameters have been defined and put together in one file. This file is downloaded at start-up into the STLC2500.

Examples of parameters are: radio configuration, PCM settings etc.

The same HCI command is used to download the file containing the patches (both those for the SW and HW mechanism).

A more detailed description of the SW parameters is available upon request.

## 7.11 Bluetooth - WLAN coexistence in collocated scenario

Bluetooth and WLAN 802.11 b/g technologies occupy the same 2.4 GHz ISM band. STLC2500 implements a set of mechanisms to avoid interference in a collocated scenario.

The STLC2500 supports 5 different algorithms in order to provide efficient and flexible simultaneous functionality between the two technologies in collocated scenarios:

- **Algorithm 1:** PTA (Packet Traffic Arbitration) based coexistence algorithm defined in accordance with the IEEE 802.15.2 recommended practice.
- **Algorithm 2:** the WLAN is the master and it indicates to the STLC2500 when not to operate in case of simultaneous use of the air interface.
- **Algorithm 3:** the STLC2500 is the master and it indicates to the WLAN chip when not to operate in case of simultaneous use of the air interface.
- **Algorithm 4:** Two-wire mechanism
- **Algorithm 5:** Alternating Wireless Medium Access (AWMA), defined in accordance with the WLAN 802.11 b/g technologies.

The algorithm is selected via HCI command. The default algorithm is algorithm 1.

### 7.11.1 Algorithm 1: PTA (Packet Traffic Arbitration)

The Algorithm is based on a bus connection between the STLC2500 and the WLAN chip:

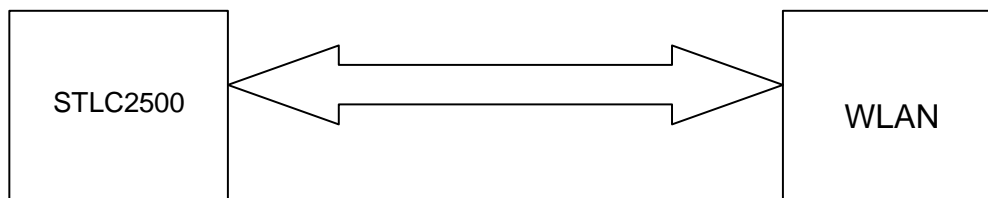

By using this coexistence interface it's possible to dynamically allocate bandwidth to the two devices when simultaneous operations are required while the full bandwidth can be allocated to one of them in case the other one does not require activity. The algorithm involves a priority mechanism, which allows preserving the quality of certain types of link. A typical application would be to guarantee optimal quality to the Bluetooth voice communication while an intensive WLAN communication is ongoing.

Several algorithms have been implemented in order to provide a maximum of flexibility and efficiency for the priority handling. Those algorithms can be activated via specific HCI commands.

The combination of a time division multiplexing techniques to share the bandwidth in case of simultaneous

## STLC2500

operations and of the priority mechanism avoid the interference due to packet collision and it allows the maximization of the 2.4 GHz ISM bandwidth usage for both devices while preserving the quality of some critical types of link.

### 7.11.2 Algorithm 2: WLAN master

In case the STLC2500 has to cooperate, in a collocated scenario, with a WLAN chip not supporting a PTA based algorithm, it's possible to put in place a simpler mechanism.

The interface is reduced to 1 line:

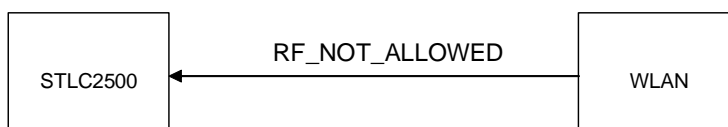

When the WLAN has to operate, it alerts HIGH the RF\_NOT\_ALLOWED signal and the STLC2500 will not operate while this signals stays HIGH.

This mechanism permits to avoid packet collision in order to make an efficient use of the bandwidth but cannot provide guaranteed quality over the Bluetooth links.

### 7.11.3 Algorithm 3: Bluetooth master

This algorithm represents the symmetrical case of section 7.11.2. Also in this case the interface is reduced to 1 line:

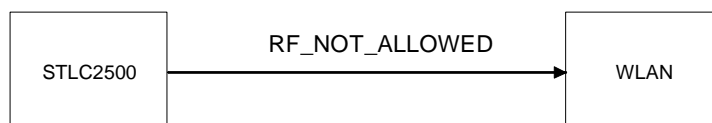

When the STLC2500 has to operate it alerts HIGH the RF\_NOT\_ALLOWED signal and the WLAN will not operate while this signals stays HIGH.

This mechanism permits to avoid packet collision in order to make an efficient use of the bandwidth, it provides high quality for all Bluetooth links but cannot provide guaranteed quality over the WLAN links.

### 7.11.4 Algorithm 4: Two-wire mechanism

Based on algorithm 2 and 3, the Host decides, on a case-by-case basis, whether WLAN or Bluetooth is master.

### 7.11.5 Algorithm 5: Alternating Wireless Medium Access (AWMA)

AWMA utilizes a portion of the WLAN beacon interval for Bluetooth operations. From a timing perspective, the medium assignment alternates between usage following WLAN procedures and usage following Bluetooth procedures.

The timing synchronization between the WLAN and the STLC2500 is done by the HW signal MEDIUM\_FREE.

**Table 19. WLAN HW signal assignment**

WLAN	Scenario 1: PTA	Scenario 2: WLAN master	Scenario 3: BT master	Scenario 4: 2-wire	Scenario 5: AWMA
WLAN 1	TX_CONFIRM	BT_RF_NOT_ALLOWED	Not used	BT_RF_NOT_ALLOWED	MEDIUM_FREE
WLAN 2	TX_REQUEST	Not used	WLAN_RF_NOT_ALLOWED	WLAN_RF_NOT_ALLOWED	Not used
WLAN 3	STATUS	Not used	Not used	Not used	Not used
WLAN 4	OPTIONAL_SIGNAL	Not used	Not used	Not used	Not used



## 8 DIGITAL INTERFACES

### 8.1 The UART interface

The STLC2500 contains a 4-pin (UART\_RXD, UART\_TXD, UART\_RTS, and UART\_CTS) UART compatible with 16450, 16550 and 16750 standards. It is running up to 1842 kbps (+1.5%/-1%).

The configuration is 8 data bits, 1 start bit, 1 stop bit, and no parity bit. 128-byte FIFO with configurable threshold interrupts for low CPU load and high throughput. Auto RTS/CTS is implemented in HW, controllable by SW.

The UART accepts all HCI commands as described in the Bluetooth specification, it supports H4 proprietary commands and the 4-wire UART sleep mode. The complete list of supported proprietary HCI commands is available in the STLC2500 Software Interface document.

Table 20 contains the list of supported baud rates selectable by HCI commands. The default baud rate is 115200 [bps].

**Table 20. List of supported baud rates**

Baud rate		
1842 k	57.6 k	4800
921.6 k	38.4 k	2400
460.8 k	28.8 k	1800
230.4 k	19.2 k	1200
153.6 k	14.4 k	900
<b>115.2 k (default)</b>	9600	600
76.8 k	7200	300

### 8.2 The PCM interface

The chip contains a 4-pin (PCM\_CLK, PCM\_SYNC, PCM\_A, and PCM\_B) direct voice interface to connect to standard CODEC including internal decimator and interpolator filters. The implementation is compliant with the MP-PCM requirements for voice transfer (8 kHz PCM\_SYNC and 8 or 16 bits data).

The four signals of the PCM interface are:

- PCM\_CLK: PCM clock
- PCM\_SYNC: PCM 8KHz sync
- PCM\_A: PCM data
- PCM\_B: PCM data

The data can be linear PCM (13-16 bit),  $\mu$ -Law (8 bit) or A-Law (8bit). The interface can be programmed as Master or as Slave via specific HCI commands.

Two additional PCM\_SYNC signals can be provided via the GPIOs. See section 8.4 for more details.

**Figure 5. PCM (A-law,  $\mu$ -law) standard mode**

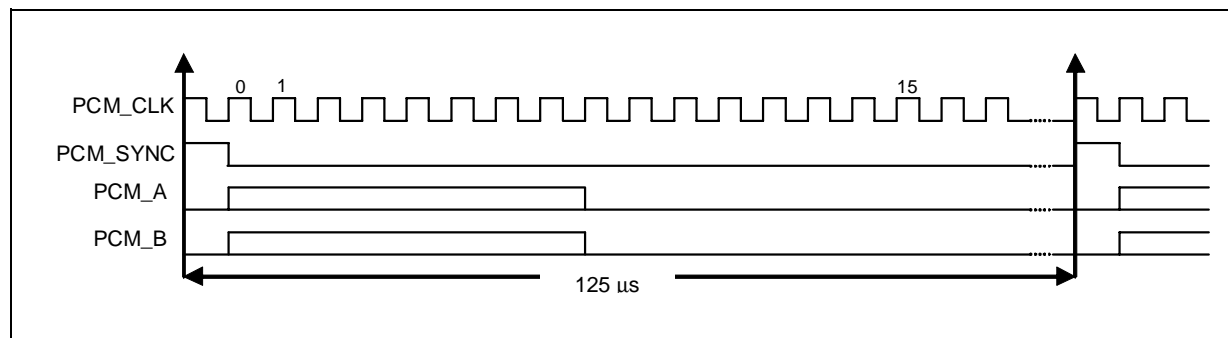

Figure 6. Linear mode

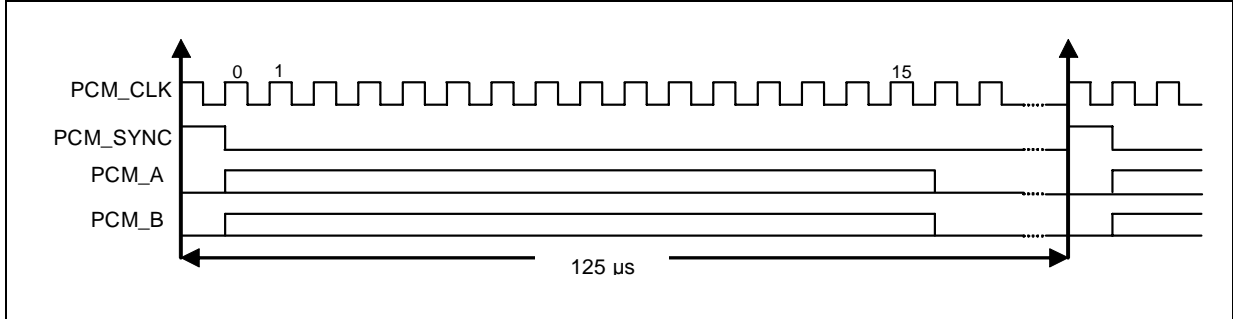
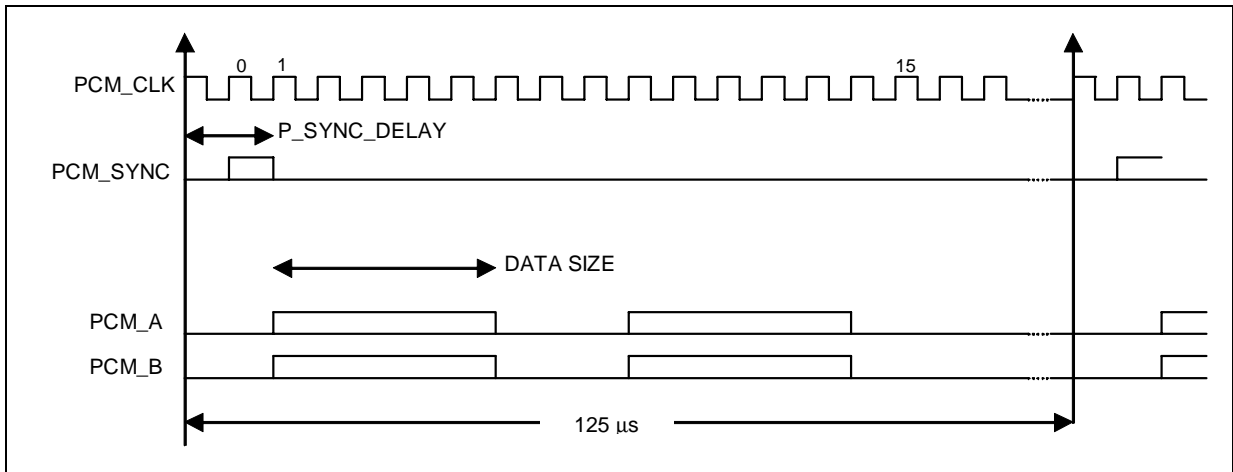

Figure 7. Multi-slot operation



The PCM implementation supports from 1 up to 3 slots per frame with the following parameters:

Table 21. PCM interface parameters

Symbol	Description	Min.	Typ.	Max.	Unit
<b>PCM Interface</b>					
F <sub>PCM_CLK</sub>	Frequency of PCM_CLK	140		4000	kHz
F <sub>PCM_SYNC</sub>	Frequency of PCM_SYNC		8		kHz
P <sub>sync_delay</sub>	Delay of the starting of the first slot	0		255	cycles
P <sub>clk_number</sub>	Available PCM_CLK clock cycles	0		255	cycles
S <sub>s</sub>	Slot starts (programmable for every slot)	0		255	cycles
D	Data size	8		16	bit
N	Number of slots per frame	1		3	

Table 22. PCM interface timing

Symbol	Description	Min.	Typ.	Max.	Unit
$t_{WCH}$	High period of PCM_CLK	200			ns
$t_{WCL}$	Low period of PCM_CLK	200			ns
$t_{WSH}$	High period of PCM_SYNC	200			ns
$t_{SSC}$	Setup time, PCM_SYNC high to PCM_CLK low	100			ns
$t_{SDC}$	Setup time, PCM_A/B input valid to PCM_CLK low	100			ns
$t_{HCD}$	Hold time, PCM_CLK low to PCM_A/B input valid	100			ns
$t_{DCD}$	Delay time, PCM_CLK high to PCM_A/B output valid			150	ns

Figure 8. PCM interface timing

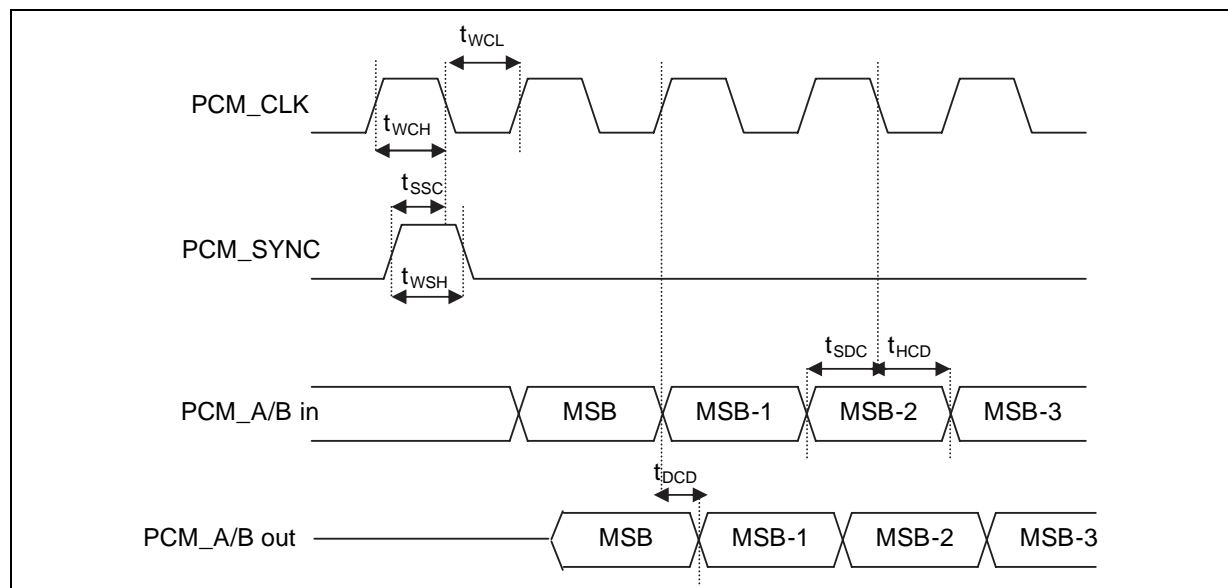

### 8.3 The JTAG interface

The JTAG interface is compliant with the JTAG IEEE Standard 1149.1. It allows both the boundary scan of the digital pins and the debug of the ARM7TDMI application when connected with the standard ARM7 developments tools. It is also used for the industrial test of the device.

### 8.4 The GPIOs

The STLC2500 has 4 GPIO pins. They are fully programmable via specific HCI commands. They can be configured as input, output, interrupt with asynchronous or synchronous edge or level detection and/or wake-up.

Also other functions are multiplexed on the GPIO pins.

The alternative functions are

- WLAN co-existence control
- I2C interface
- PCM synchronization;
- GPIOs

Some functions are mutually exclusive, as per table 23.

Table 23. GPIO multiplexing

Multiplexed GPIOs			
WLAN (See also table 19.)	I2C	PCM	GPIO
WLAN 1	I2C clock	[I2C or GPIO]	GPIO 0
WLAN 2	I2C data	[I2C or GPIO]	GPIO 1
WLAN 3	[PCM or GPIO]	PCM sync 1	GPIO 2
WLAN 4	[PCM or GPIO]	PCM sync 2	GPIO 3

**8.5 The I2C interface**

The I2C interface (version 2.1) has been specified by Philips.

The I2C interface is used to access I2C peripherals.

The implemented interface is a fast master I2C; it has full control of the interface at all times. I2C slave functionality is not supported, forcing attached devices to be slave, otherwise bus contention will occur.

**9 HCI UART TRANSPORT LAYER**

The UART transport Layer has been specified by the Bluetooth SIG and allows HCI level communication between a Bluetooth controller (STLC2500) and a Host (e.g. a GSM), via a serial line.

The objective of this HCI UART Transport Layer is to make possible to use Bluetooth HCI over a serial interface between two UARTs on the same PCB. The HCI UART Transport Layer assumes that the UART communication is free from line errors.

**UART Settings**

The HCI UART Transport Layer uses the following settings for RS232:

- Baud rate: configurable (default baud rate 115.2 [kbps])
- Number of data bits: 8
- Parity bit: no parity
- Stop bit: 1 stop bit
- Flow control: RTS/CTS
- Flow-off response time: 3 ms

Flow control with RTS/CTS is used to prevent temporary UART buffer overrun. It should not be used for flow control of HCI, since HCI has its own flow control mechanism for HCI commands, HCI events and HCI data.

If CTS is high, then the Host/Bluetooth controller is allowed to send.

If CTS is low, then the Host/Bluetooth controller is not allowed to send.

The flow-off response time defines the maximum time from setting RTS low until the byte flow actually stops. The RS232 signals should be connected in a null-modem fashion, i.e. the local TXD should be connected to the remote RXD and the local RTS should be connected to the remote CTS and vice versa.

Figure 9. UART Transport Layer

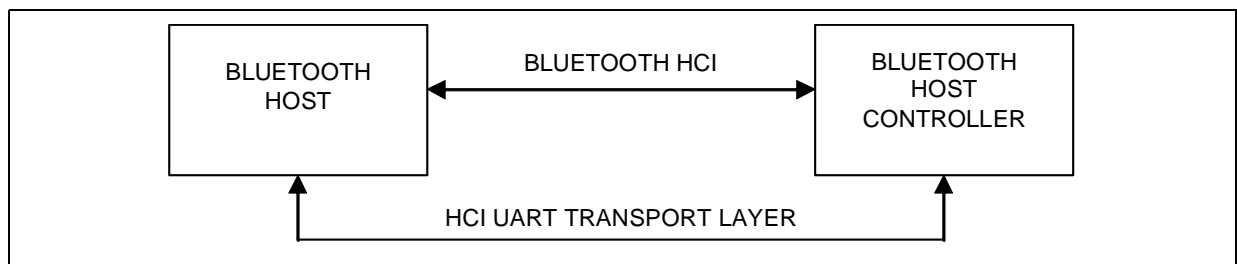
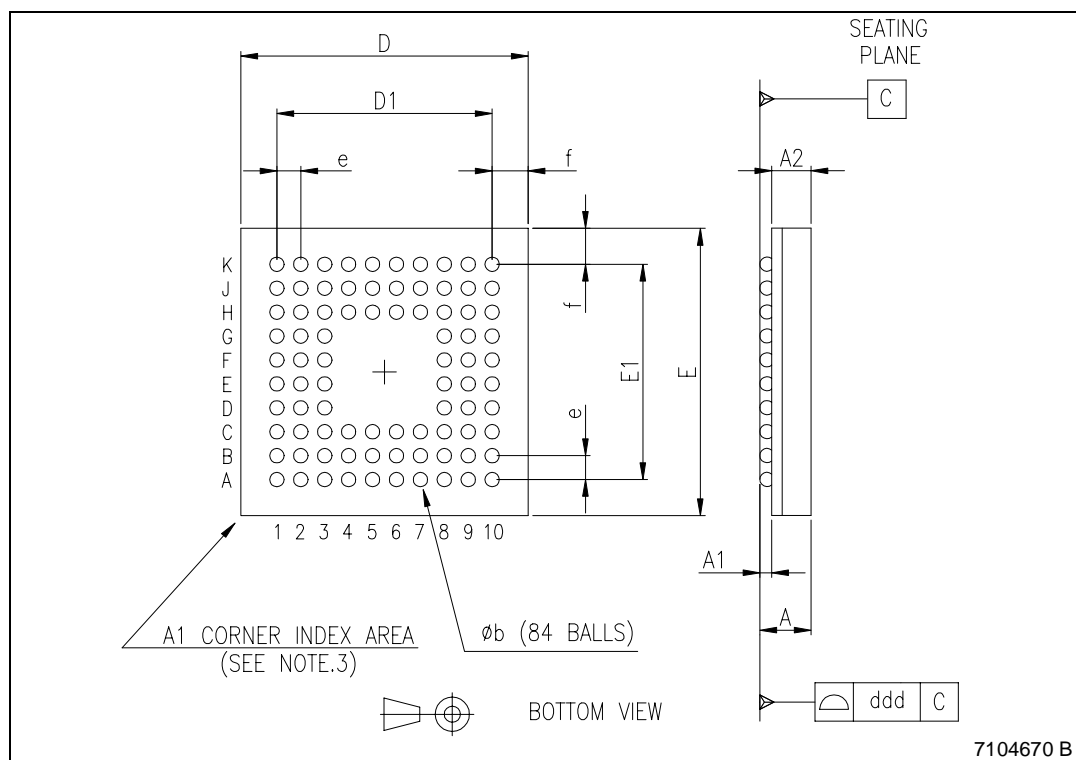
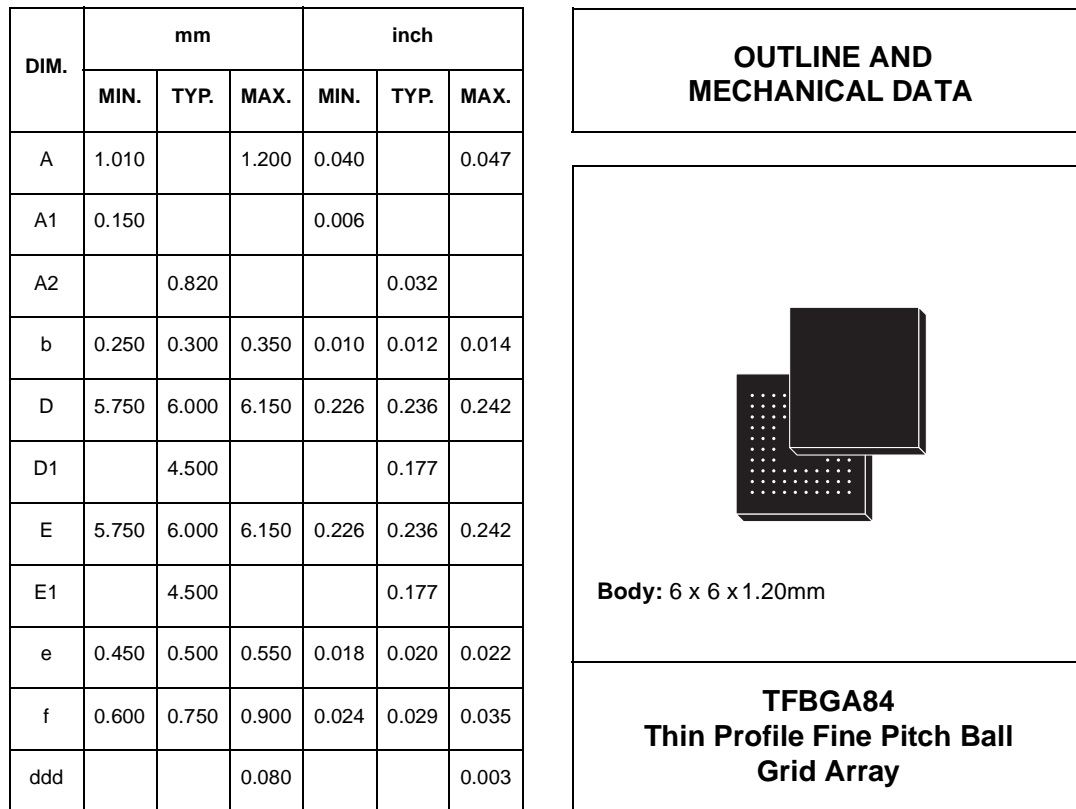

Figure 10. TFBGA84 Mechanical Data & Package Dimensions



## STLC2500

---

**Table 24. Revision History**

Date	Revision	Description of Changes
May 2004	1	First Issue

Information furnished is believed to be accurate and reliable. However, STMicroelectronics assumes no responsibility for the consequences of use of such information nor for any infringement of patents or other rights of third parties which may result from its use. No license is granted by implication or otherwise under any patent or patent rights of STMicroelectronics. Specifications mentioned in this publication are subject to change without notice. This publication supersedes and replaces all information previously supplied. STMicroelectronics products are not authorized for use as critical components in life support devices or systems without express written approval of STMicroelectronics.

The ST logo is a registered trademark of STMicroelectronics.

The BLUETOOTH™ word mark and logos are owned by the Bluetooth SIG, Inc. and any use of such marks by STMicroelectronics is under license. All other names are the property of their respective owners

© 2004 STMicroelectronics - All rights reserved

**STMicroelectronics GROUP OF COMPANIES**

Australia - Belgium - Brazil - Canada - China - Czech Republic - Finland - France - Germany - Hong Kong - India - Israel - Italy - Japan - Malaysia - Malta - Morocco - Singapore - Spain - Sweden - Switzerland - United Kingdom - United States

[www.st.com](http://www.st.com)