



STM376-2

RF POWER MODULE WIRELESS LOCAL LOOP APPLICATIONS

PRELIMINARY DATA

- LINEAR POWER AMPLIFIER
- 350-376 MHz
- 20 VOLTS
- INPUT/OUTPUT 50 OHMS
- $P_{OUT} = 1.0 W_{AVG}$ (2.0 W PEP)
- GAIN = 21 dB

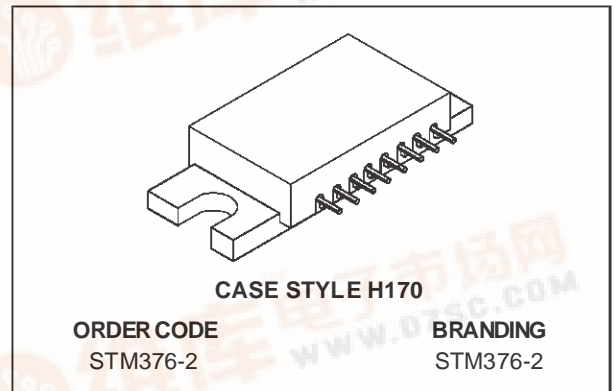

DESCRIPTION

The STM376-2 module is designed to be used as a linear RF Power Amplifier for WLL or other fixed radio access subscriber applications. This particular model is one of several in design covering the 300-500 MHz frequency range in individual bandwidths of 25 MHz each.

Band splits and corresponding part numbers for all bands are as follows:

STM326-2	300-326 MHz	
STM351-2	325-351 MHz	PROTOTYPES
STM376-2	350-376 MHz	AVAILABLE
STM401-2	375-401 MHz	
STM426-2	400-426 MHz	
STM451-2	425-451 MHz	
STM476-2	450-476 MHz	
STM500-2	475-500 MHz	

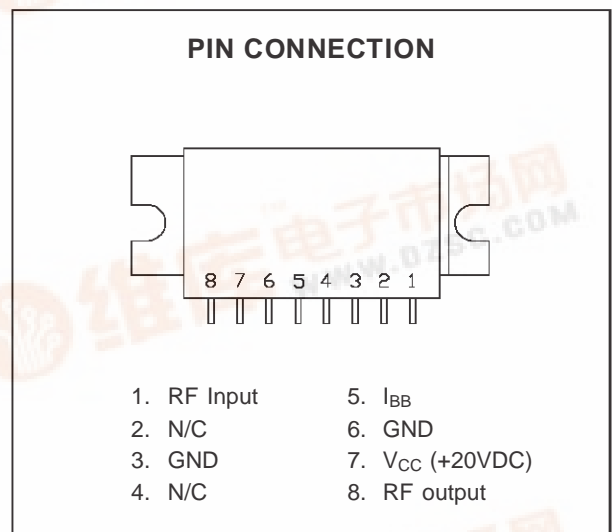

ABSOLUTE MAXIMUM RATINGS (T_{case} = 25°C)

Symbol	Parameter	Value	Unit
V _{CC}	DC Supply Voltage	+21	Vdc
I _{CC(q)}	Quiescent Current (pin 7)	200	mAdc
I _{CC}	Operating Current (pin 7)	500	mAdc
P _{IN}	RF Input Power	30	mW
P _{OUT}	RF Output Power	2.0	W _{AVG}
T _{STG}	Storage Temperature	-30 to +100	°C
T _c	Operating Case Temperature	- 20 to +60	°C

PACKAGE MECHANICAL DATA

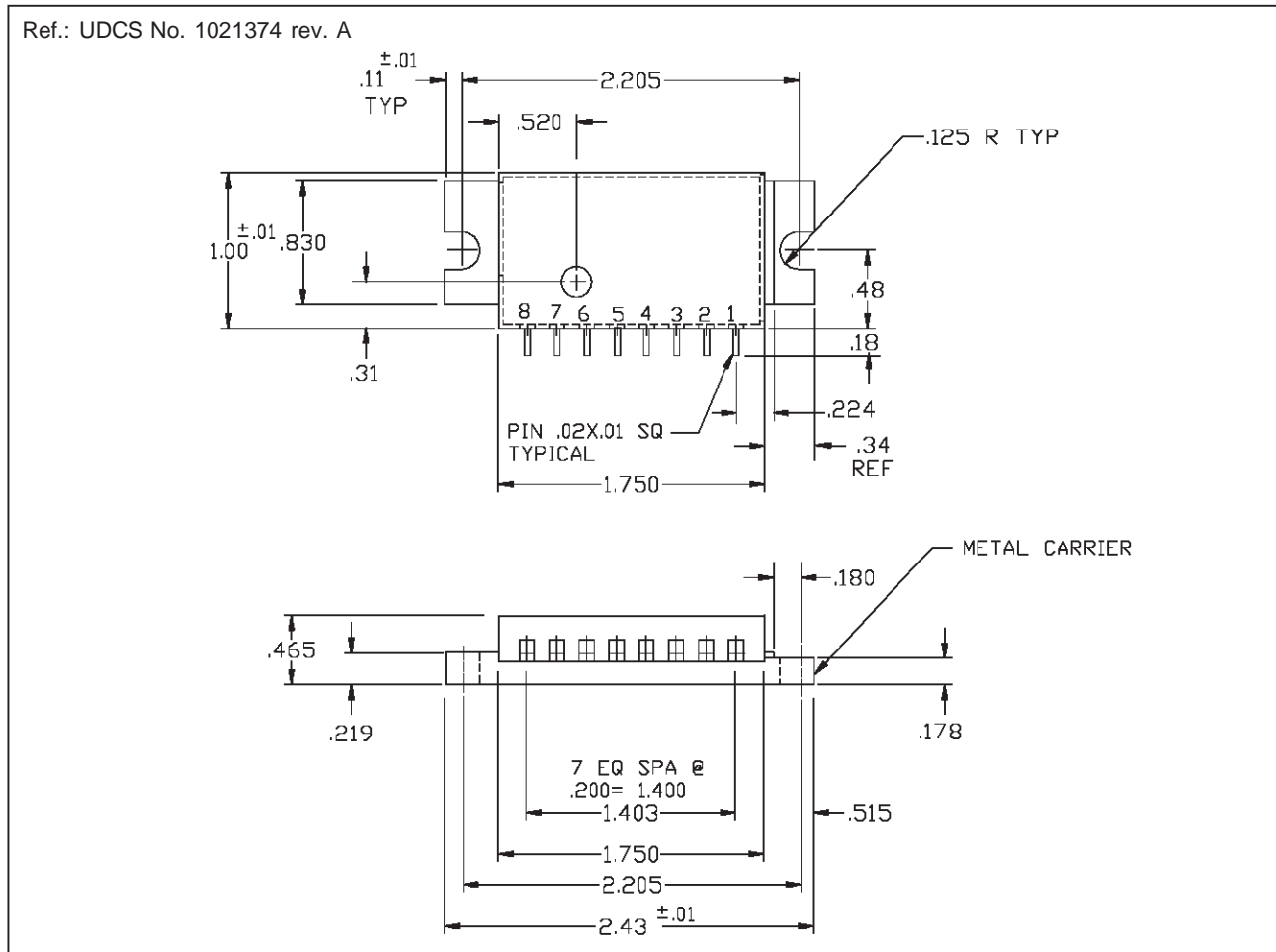

Information furnished is believed to be accurate and reliable. However, STMicroelectronics assumes no responsibility for the consequences of use of such information nor for any infringement of patents or other rights of third parties which may result from its use. No license is granted by implication or otherwise under any patent or patent rights of STMicroelectronics. Specifications mentioned in this publication are subject to change without notice. This publication supersedes and replaces all information previously supplied. STMicroelectronics products are not authorized for use as critical components in life support devices or systems without express written approval of STMicroelectronics.

The ST logo is a registered trademark of STMicroelectronics

©1998 STMicroelectronics - All Rights Reserved

STMicroelectronics GROUP OF COMPANIES

Australia - Brazil - Canada - China - France - Germany - Italy - Japan - Korea
 Malaysia - Malta - Mexico - Morocco - The Netherlands - Singapore - Spain - Sweden - Switzerland
 Taiwan - Thailand - United Kingdom - U.S.A.