

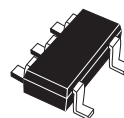


# STM6717/6718/6719/6720 STM6777/6778/6779/6780

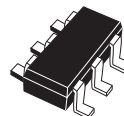
Dual/triple ultra-low voltage supervisors  
with push-button reset (with delay option)

## Features

- Primary supply ( $V_{CC1}$ ) monitor. Fixed (factory-programmed) reset thresholds: 4.63V to 1.58V
- Secondary supply ( $V_{CC2}$ ) monitor (STM6717/18/19/20/77/78).
- Fixed (factory-programmed) reset thresholds: 3.08V to 0.79V
- Tertiary supply monitor (using externally adjustable  $rstin$ ):
- 0.626V internal reference
- $\overline{RST}$  outputs (push-pull or open drain); state guaranteed IF  $V_{CC1}$  OR  $V_{CC2} \geq 0.8V$
- Reset delay time ( $t_{rec}$ ) on power-up: 210ms(typ)
- Manual reset input ( $\overline{MR}$ )
- Optional delayed manual reset input (MRC) with external capacitor (STM6777/78/79/80)
- Low supply current - 11 $\mu$ A (typ),  $V_{CC1} = V_{CC2} = 3.6V$
- Operating temperature:  $-40^{\circ}C$  to  $85^{\circ}C$  (industrial grade)



SOT23-5 (WY)



SOT23-6 (WB)

Table 1. Device options

Part number	Monitored voltages			Manual reset input ( $\overline{MR}$ )	Delayed $\overline{MR}$ pin (MRC)	Reset output ( $\overline{RST}$ )		Package
	$V_{CC1}$	$V_{CC2}$	RSTIN			Active-low (push-pull)	Active-low (open drain)	
STM6717	✓	✓		✓			✓	WY
STM6718	✓	✓		✓		✓		WY
STM6719	✓	✓	✓	✓			✓	WB
STM6720	✓	✓	✓	✓		✓		WB
STM6777	✓	✓		✓	✓		✓	WB
STM6778	✓	✓		✓	✓	✓		WB
STM6779	✓		✓	✓	✓		✓	WB
STM6780	✓		✓	✓	✓	✓		WB

# Contents

**Summary description . . . . . 5**

    Pin Descriptions . . . . . 7

        Active-Low, Push-pull Reset Output (RST) - STM6718/20/78/80 . . . . . 7

        Active-Low, Open Drain Reset Output (RST) - STM6717/19/77/79. . . . . 7

        Push-Button Reset Input (MR). . . . . 7

        Manual Reset Delay Input (MRC) - STM6777/78/79/80). . . . . 8

        Primary Supply Voltage Monitoring Input ( $V_{CC1}$ ) . . . . . 8

        Secondary Supply Voltage Monitoring Input ( $V_{CC2}$ ) . . . . . 8

        Adjustable Reset Comparator Input (RSTIN; STM6719/20/79/80) . . . . . 8

**Operation . . . . . 10**

    Applications Information . . . . . 10

**Typical operating characteristics . . . . . 11**

**Maximum rating. . . . . 17**

**DC and AC parameters . . . . . 18**

**Package mechanical data. . . . . 22**

**Part numbering . . . . . 25**

**Revision history . . . . . 26**

## List of tables

Table 1.	Device options	1
Table 2.	Signal names	6
Table 3.	Pin functions	8
Table 4.	Absolute maximum ratings	17
Table 5.	Operating and AC measurement conditions	18
Table 6.	DC and AC characteristics	19
Table 7.	$t_{MLMH}$ Minimum pulse width	21
Table 8.	SOT23-5 – 5-lead small outline transistor package mechanical data	23
Table 9.	SOT23-6 – 6-lead small outline transistor package mechanical data	24
Table 10.	Ordering information scheme	25
Table 11.	Document revision history	26

## List of figures

Figure 1.	Logic diagram (STM6717/18) . . . . .	6
Figure 2.	Logic diagram (STM6777/78) . . . . .	6
Figure 3.	Logic diagram (STM6719/20) . . . . .	6
Figure 4.	Logic diagram (STM6779/80) . . . . .	6
Figure 5.	STM6717/18 SOT23-5 connections . . . . .	7
Figure 6.	STM6777/78 SOT23-6 connections . . . . .	7
Figure 7.	STM6719/20 SOT23-6 connections . . . . .	7
Figure 8.	STM6779/80 SOT23-6 connections . . . . .	7
Figure 9.	Block diagram . . . . .	9
Figure 10.	Hardware hookup . . . . .	9
Figure 11.	STM67xx interface to processor with bi-directional reset pins . . . . .	10
Figure 12.	Ensuring RST valid to $V_{CC} = 0$ (active-low, push-pull outputs) . . . . .	10
Figure 13.	Supply current vs. temperature ( $V_{CC1} = 5.5V$ ; $V_{CC2} = 3.6V$ ) . . . . .	11
Figure 14.	Supply current vs. temperature ( $V_{CC1} = 3.6V$ ; $V_{CC2} = 2.75V$ ) . . . . .	11
Figure 15.	Supply current vs. temperature ( $V_{CC1} = 3.0V$ ; $V_{CC2} = 2.0V$ ) . . . . .	12
Figure 16.	Supply current vs. temperature ( $V_{CC1} = 2.0V$ ; $V_{CC2} = 1.0V$ ) . . . . .	12
Figure 17.	Normalized $V_{CC}$ reset time-out period vs. temperature . . . . .	13
Figure 18.	Maximum $V_{CC}$ transient duration vs. reset threshold overdrive . . . . .	13
Figure 19.	Normalized $V_{RST1}$ threshold vs. temperature . . . . .	14
Figure 20.	Normalized $V_{RST2}$ threshold vs. temperature . . . . .	14
Figure 21.	Reset input threshold vs. temperature . . . . .	15
Figure 22.	$V_{CC1}$ -to-reset delay vs. temperature . . . . .	15
Figure 23.	Reset input-to-reset output delay vs. temperature . . . . .	16
Figure 24.	MR-to-reset output delay vs. temperature ( $V_{CC1} = 3.6V$ ) . . . . .	16
Figure 25.	AC Testing Input/Output Waveforms . . . . .	18
Figure 26.	MR timing waveform (STM6717/18/19/20) . . . . .	18
Figure 27.	MR timing waveform (STM6777/78/79/80) . . . . .	18
Figure 28.	SOT23-5 – 5-lead small outline transistor package mechanical drawing . . . . .	22
Figure 29.	SOT23-6 – 6-lead small outline transistor package mechanical drawing . . . . .	23

## Summary description

The STM6717/18/19/20 and STM6777/78/79/80 Supervisors are a family of low voltage/low supply current processor (Micro or DSP) Supervisors, designed to monitor two (or three) system power supply voltages. They are targeted at applications such as Set-Top Boxes (STBs), portable, battery-powered systems, networking, and communication systems.

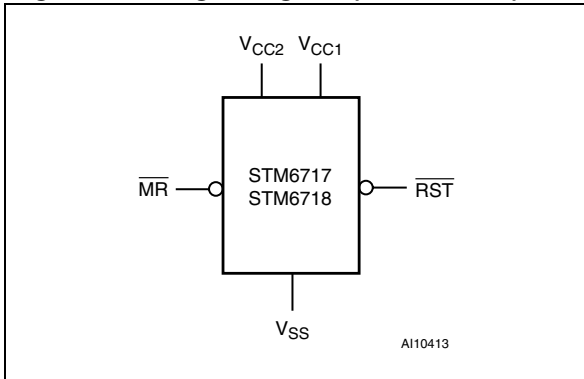
All device options have a push-button-type manual reset input ( $\overline{MR}$ ). The STM6777/78/79/80 also includes an option which enables the user to delay the start of the Manual Reset process from 6 $\mu$ s (MRC pin left open) or more with external capacitor. The delay is implemented by connecting the appropriately sized capacitor between the MRC pin and  $V_{SS}$  (typical 4s delay with a 3.3 $\mu$ F capacitor, see [Table 7 on page 21](#)).

Two of the three supplies monitored ( $V_{CC1}$  and  $V_{CC2}$ ) have fixed (customer-selectable, factory-trimmed) thresholds ( $V_{RST1}$  and  $V_{RST2}$ ). The third voltage is monitored using an externally adjustable RSTIN threshold (0.626V internal reference).

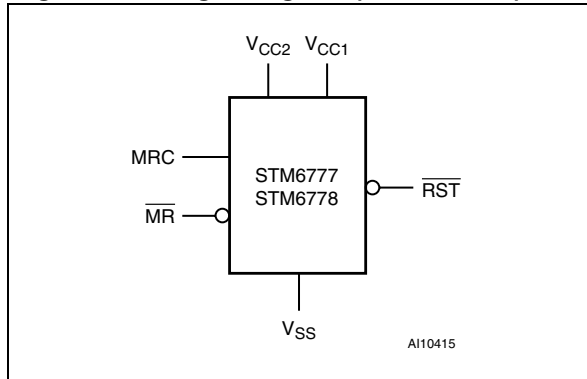
If any of the three monitored voltages drop below its factory-trimmed or adjustable thresholds, or if  $\overline{MR}$  is asserted to logic low, a  $\overline{RST}$  is asserted (driven low). Once asserted,  $\overline{RST}$  is maintained at Low for a minimum delay period ( $t_{rec}$ ) after ALL supplies rise above their respective thresholds and  $\overline{MR}$  returns to High. These devices are guaranteed to be in the correct reset output logic state when  $V_{CC1}$  and/or  $V_{CC2}$  is greater than 0.8V.

These devices are available in a standard 5-pin or 6-pin SOT23 packages (see [Table 1 on page 1](#)).

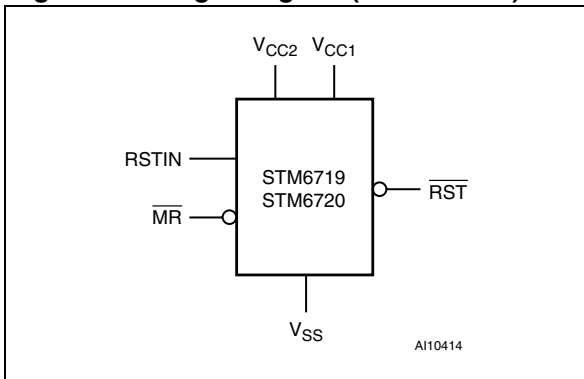
**Figure 1. Logic diagram (STM6717/18)**



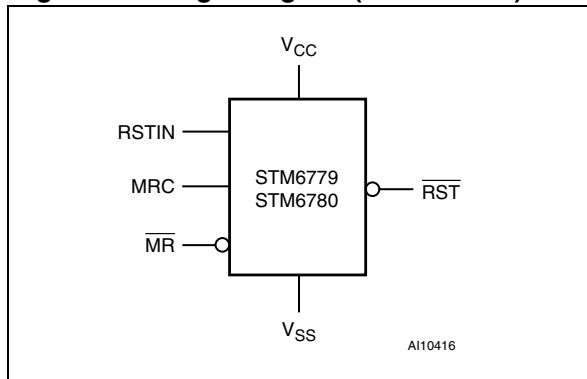
**Figure 2. Logic diagram (STM6777/78)**



**Figure 3. Logic diagram (STM6719/20)**



**Figure 4. Logic diagram (STM6779/80)**



**Table 2. Signal names**

MR	Push-button reset input
MRC	Manual reset delay input
RST	Active-low reset output
V <sub>CC1</sub>	Primary supply voltage input
V <sub>CC2</sub>	Secondary supply voltage input
RSTIN	Adjustable reset comparator input
V <sub>SS</sub>	Ground

Figure 5. STM6717/18 SOT23-5 connections

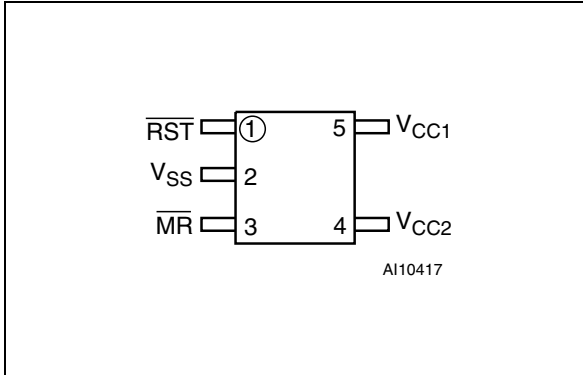


Figure 6. STM6777/78 SOT23-6 connections

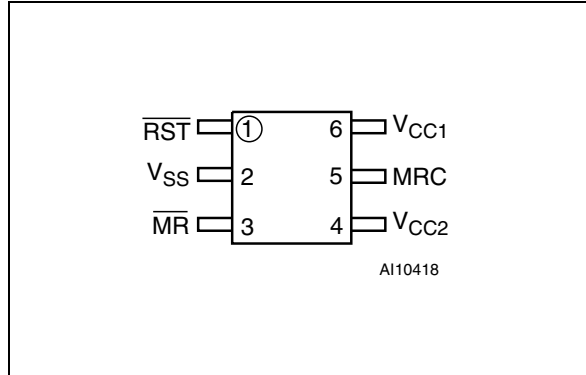


Figure 7. STM6719/20 SOT23-6 connections

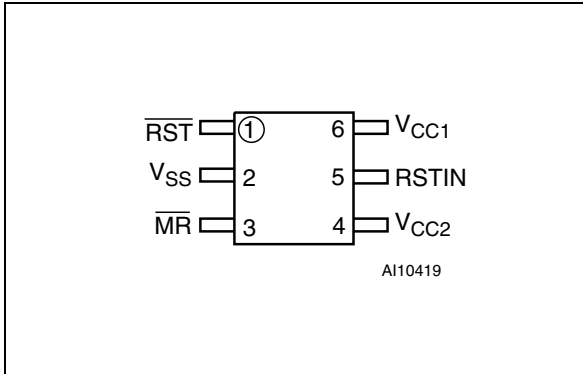
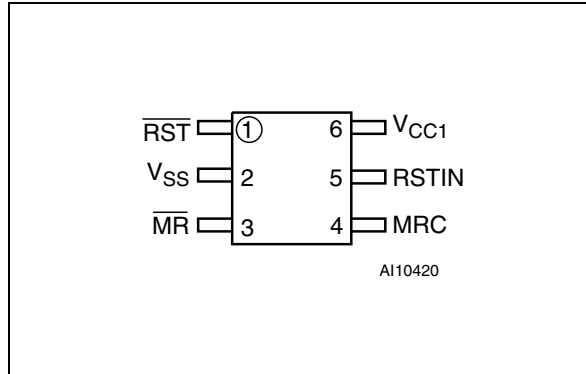


Figure 8. STM6779/80 SOT23-6 connections



## Pin Descriptions

### Active-Low, Push-pull Reset Output ( $\overline{\text{RST}}$ ) - STM6718/20/78/80

The  $\overline{\text{RST}}$  pin is driven low and stays low whenever  $V_{\text{CC1}}$  or  $V_{\text{CC2}}$  or RSTIN falls below its factory-trimmed or adjustable reset threshold or when MR goes to logic low. It remains low for  $t_{\text{rec}}$  after ALL supply voltages being monitored rise above their reset thresholds and MR goes from low to high. (Push-pull outputs are referenced to  $V_{\text{CC1}}$ .)

### Active-Low, Open Drain Reset Output ( $\overline{\text{RST}}$ ) - STM6717/19/77/79

The  $\overline{\text{RST}}$  pin is driven low and stays low whenever  $V_{\text{CC1}}$  or  $V_{\text{CC2}}$  or RSTIN falls below its factory-trimmed or adjustable reset threshold or when MR goes to logic low. It remains low for  $t_{\text{rec}}$  after ALL supply voltages being monitored rise above their reset thresholds and MR goes from low to high. Connect an external pull-up resistor to  $V_{\text{CC1}}$ . A 10k $\Omega$  pull-up resistor should be sufficient for most applications.

### Push-Button Reset Input ( $\overline{\text{MR}}$ )

When  $\overline{\text{MR}}$  goes low the  $\overline{\text{RST}}$  output is driven low.  $\overline{\text{RST}}$  remains low as long as  $\overline{\text{MR}}$  is low and for  $t_{\text{rec}}$  after  $\overline{\text{MR}}$  returns to high. This active-low input has an internal 50k $\Omega$  pull-up resistor to

$V_{CC1}$ . It can be driven from a TTL or CMOS logic line, or with open drain/collector outputs, or connected to  $V_{SS}$  through a switch. If unused, leave this pin open or connect it to  $V_{CC1}$ .

Connect a normally open momentary switch from  $\overline{MR}$  to  $V_{SS}$ ; external debounce circuitry is not required. (If  $\overline{MR}$  is driven from long cables or if the device is used in noisy environments, connecting a 0.1 $\mu$ F capacitor from  $\overline{MR}$  to  $V_{SS}$  provides additional noise immunity.

### Manual Reset Delay Input (MRC) - STM6777/78/79/80)

This pin is either left open or connected to  $V_{SS}$  via a capacitor. By selecting the appropriate capacitor, the manual reset process, initiated by pressing the push-button Manual Reset Input, can be delayed by any value from 6 $\mu$ s or more (see [Table 7 on page 21](#)).

### Primary Supply Voltage Monitoring Input ( $V_{CC1}$ )

It also is the input for the primary reset threshold monitor. Available fixed (customer-selectable, factory-programmed) reset thresholds include 4.63V to 1.58V.

### Secondary Supply Voltage Monitoring Input ( $V_{CC2}$ )

This function is available on the STM6717/18/19/20/77/78. Fixed (customer-selectable, factory-programmed) reset thresholds include 3.08V to 0.79V.

### Adjustable Reset Comparator Input (RSTIN; STM6719/20/79/80)

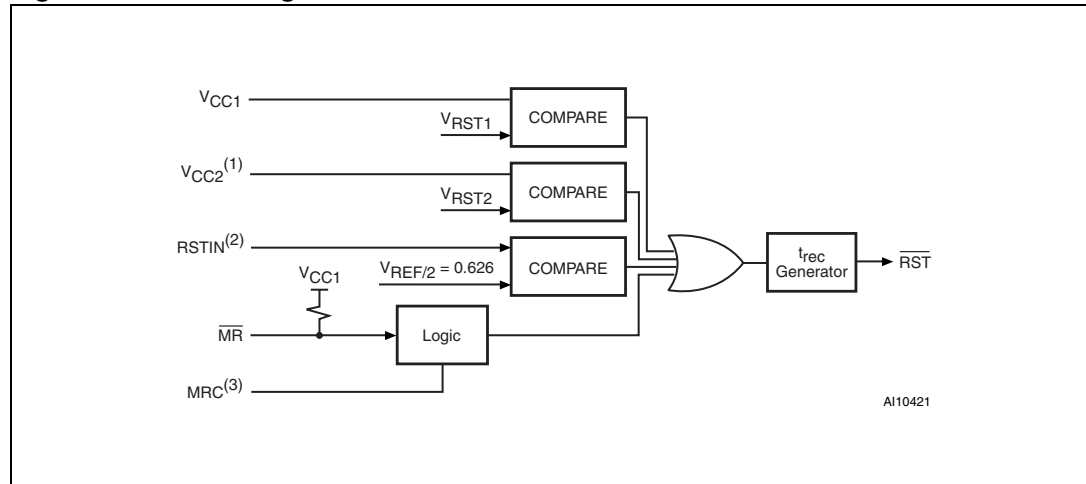
This is a high impedance input.  $\overline{RST}$  is driven low when the voltage at the RSTIN pin falls below 0.626V (internal reference voltage at this comparator). The monitored voltage reset threshold is set with an external resistor-divider network.

**Table 3. Pin functions**

Pin				Name	Function
STM6717 STM6718	STM6719 STM6720	STM6777 STM6778	STM6779 STM6780		
1	1	1	1	RST	Active-low reset output
3	3	3	3	MR	Push-button reset input
–	–	5	4	MRC	Manual reset delay input
5	6	6	6	$V_{CC1}$	Primary supply voltage input
4	4	4	–	$V_{CC2}$	Secondary supply voltage input
–	5	–	5	RSTIN	Adjustable reset comparator input
2	2	2	2	$V_{SS}$	Ground

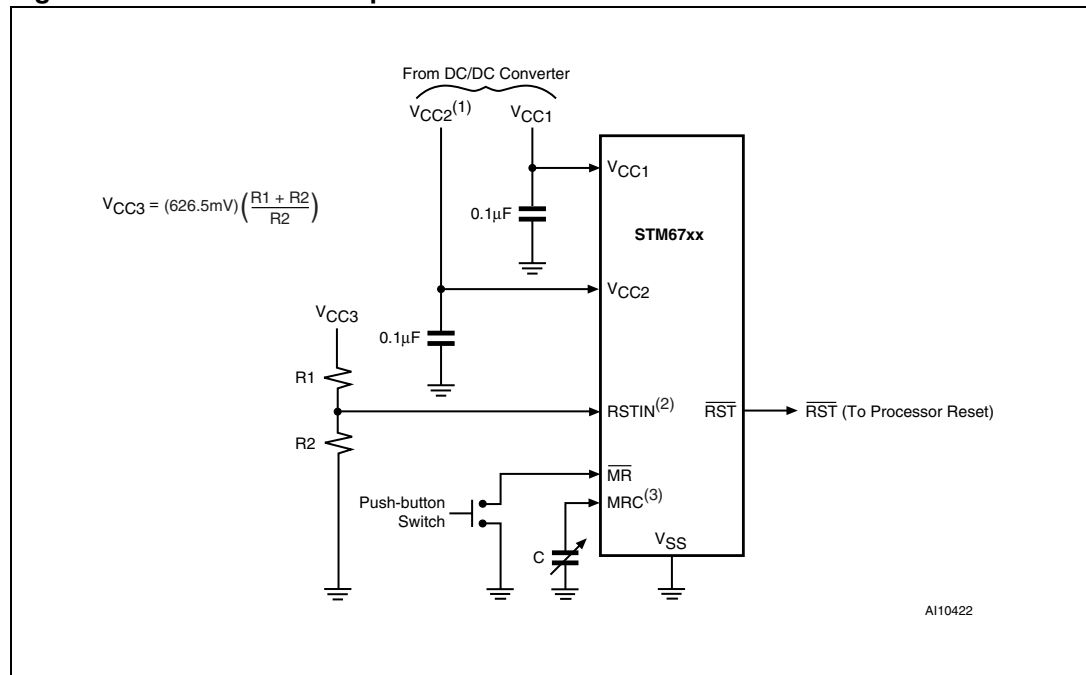


**Figure 9. Block diagram**



1. V<sub>CC2</sub> Input is available on STM6717/18/19/20/77/78.
2. RSTIN available only on STM6719/20/79/80.
3. MRC available only on STM6777/78/79/80.

**Figure 10. Hardware hookup**



1. V<sub>CC2</sub> is available only on STM6717/18/19/20/77/78.
2. RSTIN available only on STM6719/20/79/80.
3. MRC available only on STM6777/78/79/80.

# Operation

## Applications Information

1. Interfacing to Processors with Bi-directional Reset Pins

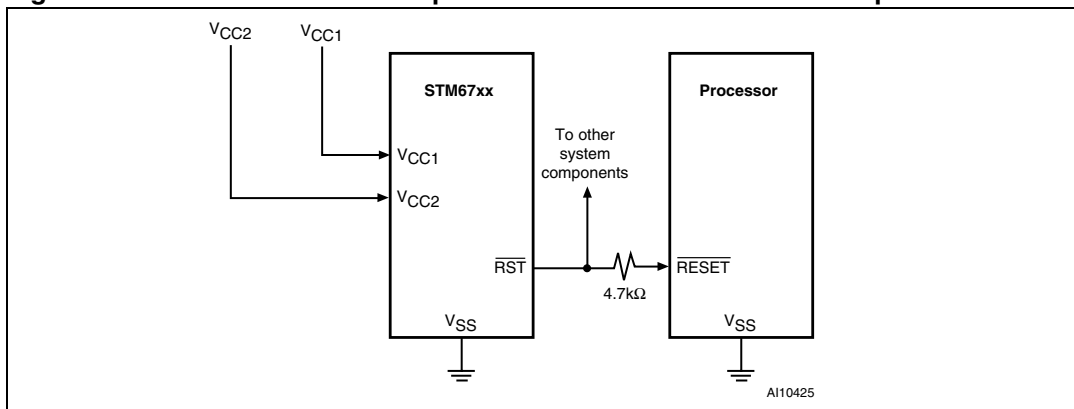
Most processors with bi-directional reset pins can interface directly to the open drain  $\overline{RST}$  outputs (STM6717/19/77/79). Systems simultaneously requiring a push-pull  $\overline{RST}$  output and a bi-directional reset interface can be in logic contention. To prevent this contention, connect a 4.7k $\Omega$  resistor between  $\overline{RST}$  and the processor's Reset I/O as shown in [Figure 11](#).

2. Ensuring a Valid  $\overline{RST}$  Output Down to  $V_{CC} = 0V$

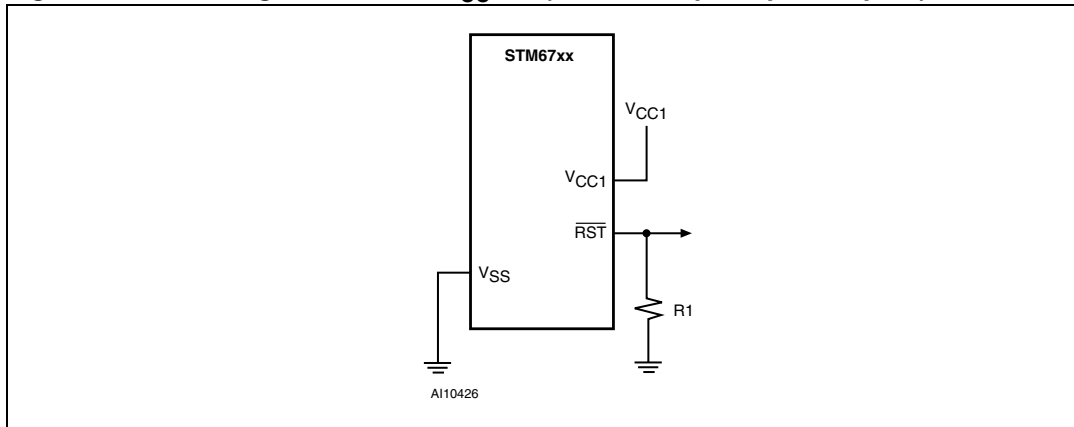
The STM67xx Supervisors are guaranteed to be in the correct  $\overline{RST}$  output logic state when  $V_{CC1}$  and/or  $V_{CC2}$  is greater than 0.8V. In applications which require valid reset levels down to  $V_{CC} = 0$ , a pull-down resistor to active-low outputs (push-pull only, see [Figure 12](#)) will ensure that the reset line is valid while the reset output can no longer sink or source current. This scheme does NOT work with the open drain outputs of the STM6717/19/77/79.

The resistor value used is not critical, but it must be large enough not to load the reset output when  $V_{CC}$  is above the reset threshold. For most applications, 100k $\Omega$  is adequate.

**Figure 11. STM67xx interface to processor with bi-directional reset pins**



**Figure 12. Ensuring  $\overline{RST}$  valid to  $V_{CC} = 0$  (active-low, push-pull outputs)**



# Typical operating characteristics

Note: Typical values are at  $T_A = 25^\circ\text{C}$  unless otherwise noted.

Figure 13. Supply current vs. temperature ( $V_{CC1} = 5.5\text{V}$ ;  $V_{CC2} = 3.6\text{V}$ )

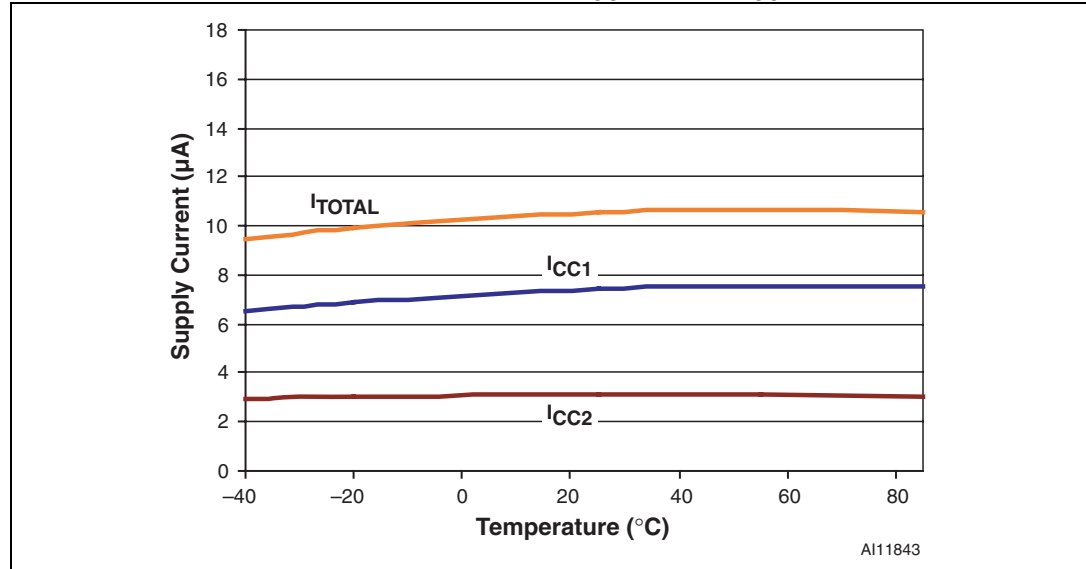


Figure 14. Supply current vs. temperature ( $V_{CC1} = 3.6\text{V}$ ;  $V_{CC2} = 2.75\text{V}$ )

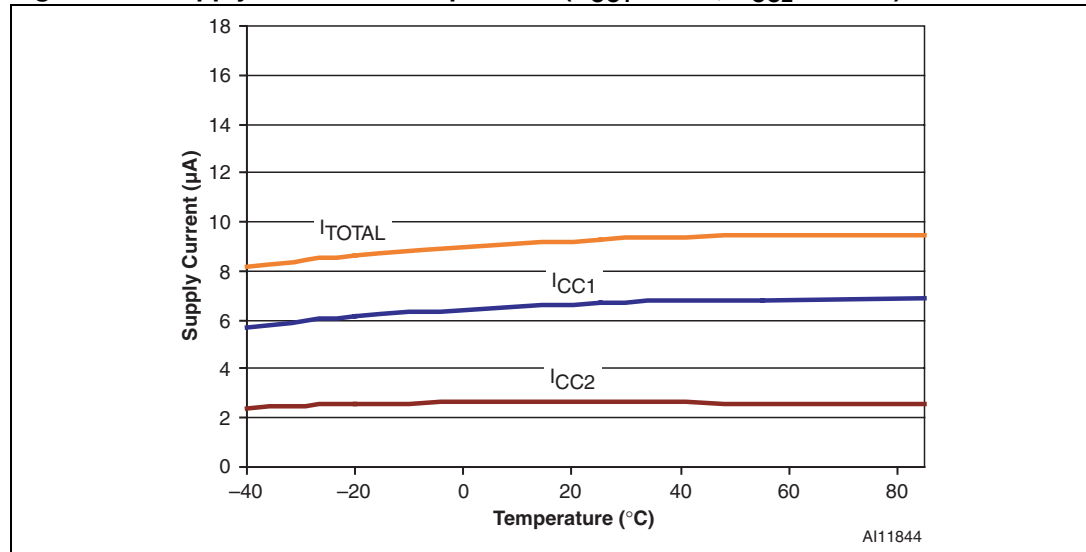


Figure 15. Supply current vs. temperature ( $V_{CC1} = 3.0V$ ;  $V_{CC2} = 2.0V$ )

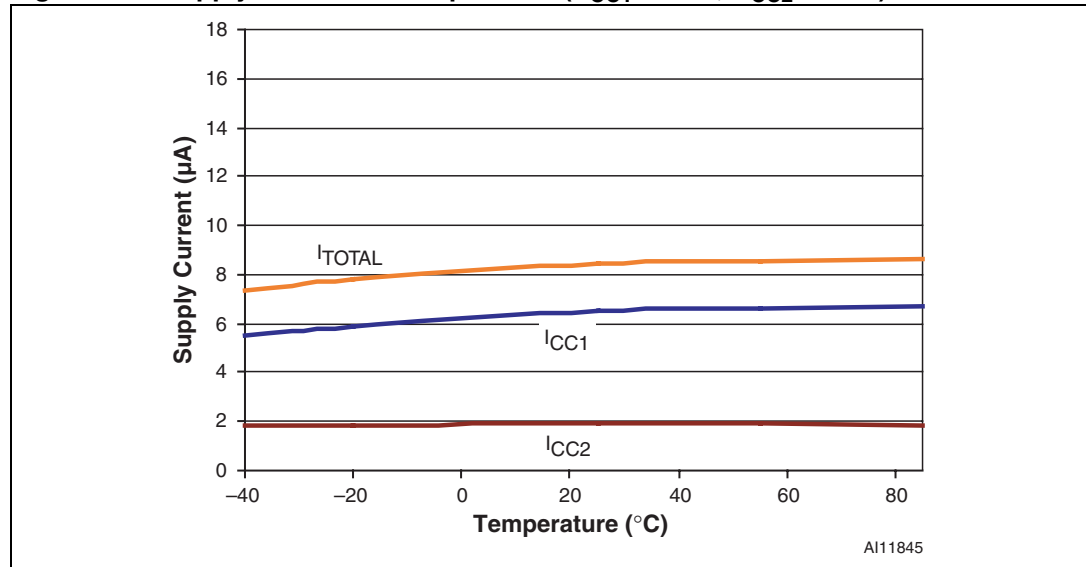


Figure 16. Supply current vs. temperature ( $V_{CC1} = 2.0V$ ;  $V_{CC2} = 1.0V$ )

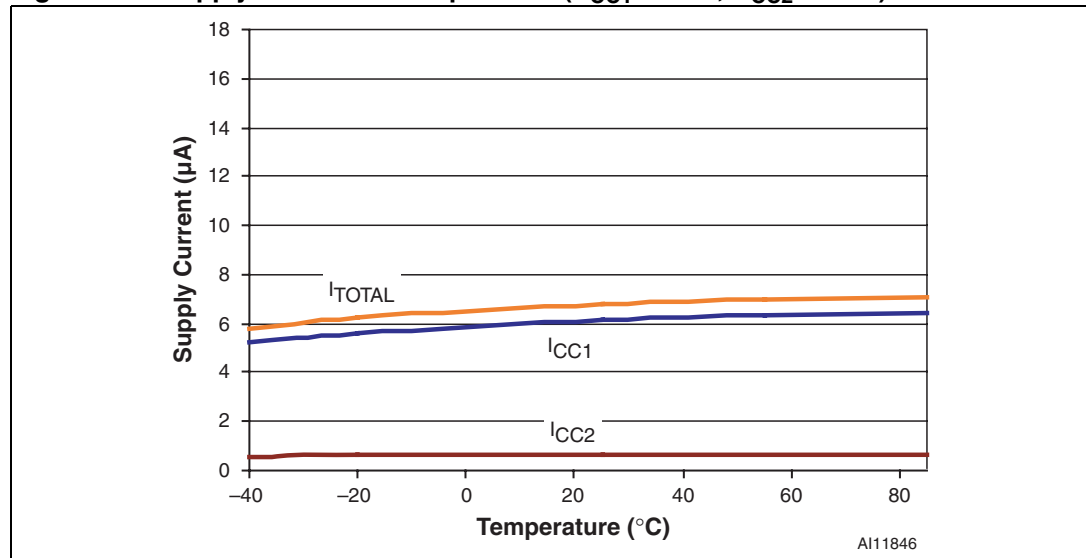


Figure 17. Normalized  $V_{CC}$  reset time-out period vs. temperature

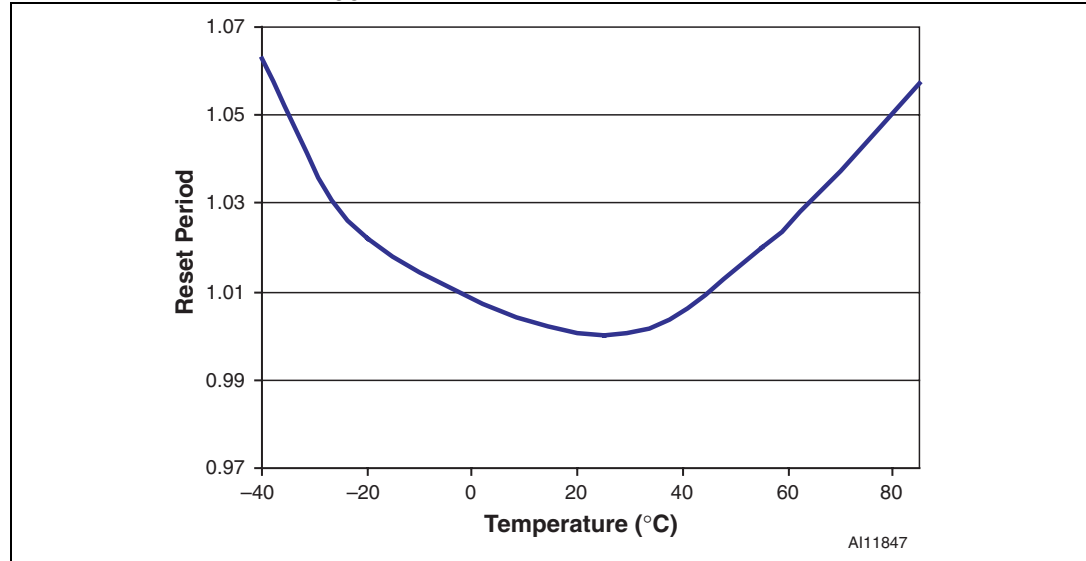


Figure 18. Maximum  $V_{CC}$  transient duration vs. reset threshold overdrive

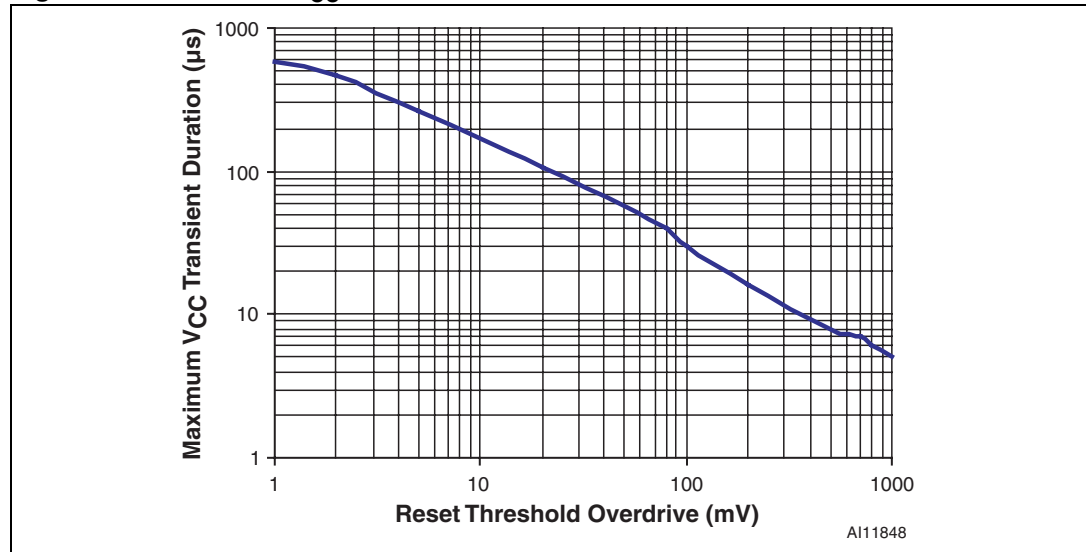


Figure 19. Normalized  $V_{RST1}$  threshold vs. temperature

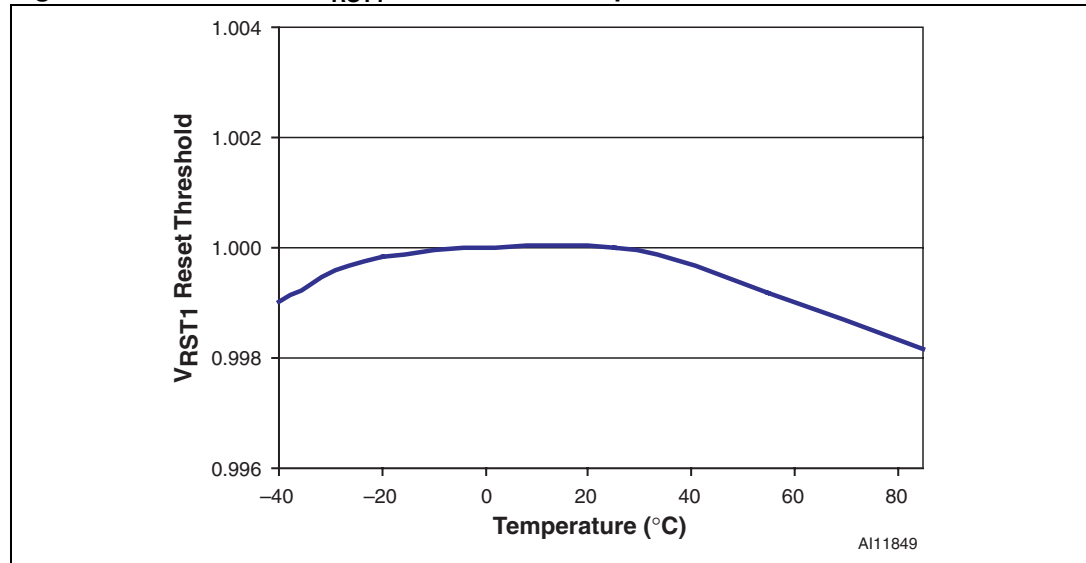


Figure 20. Normalized  $V_{RST2}$  threshold vs. temperature

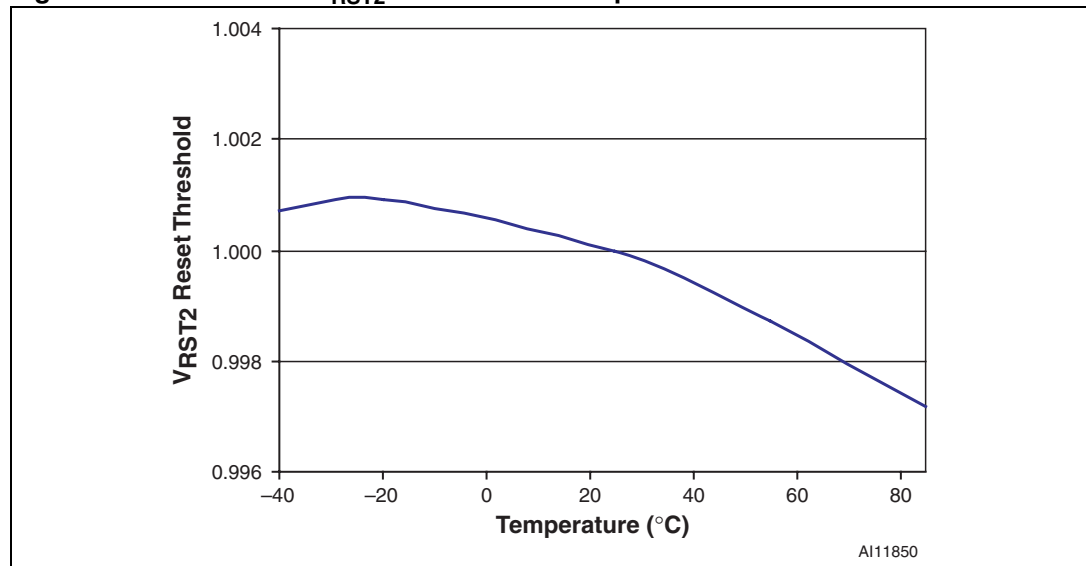


Figure 21. Reset input threshold vs. temperature

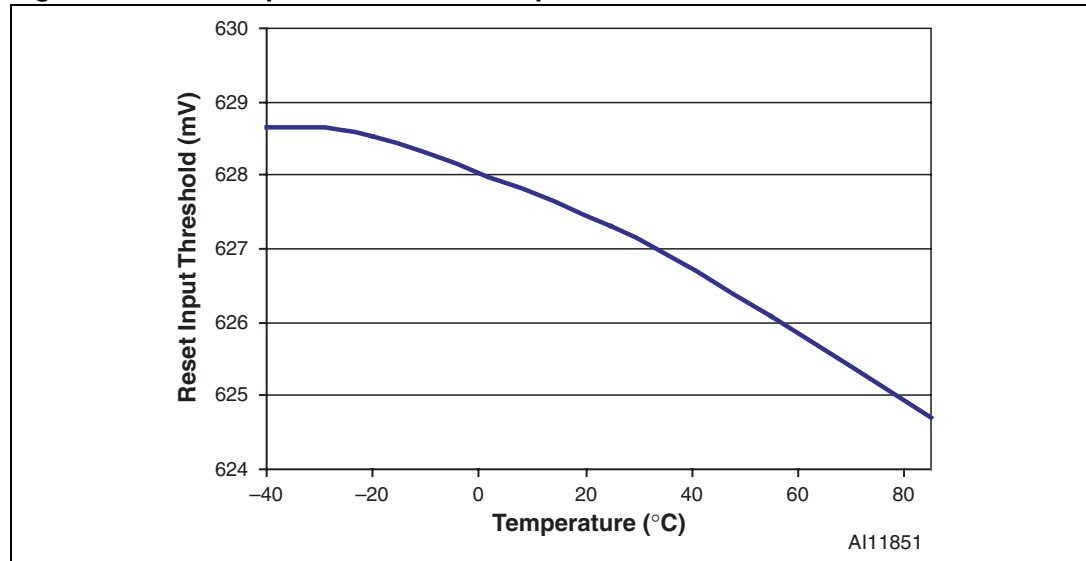


Figure 22. V<sub>CC1</sub>-to-reset delay vs. temperature

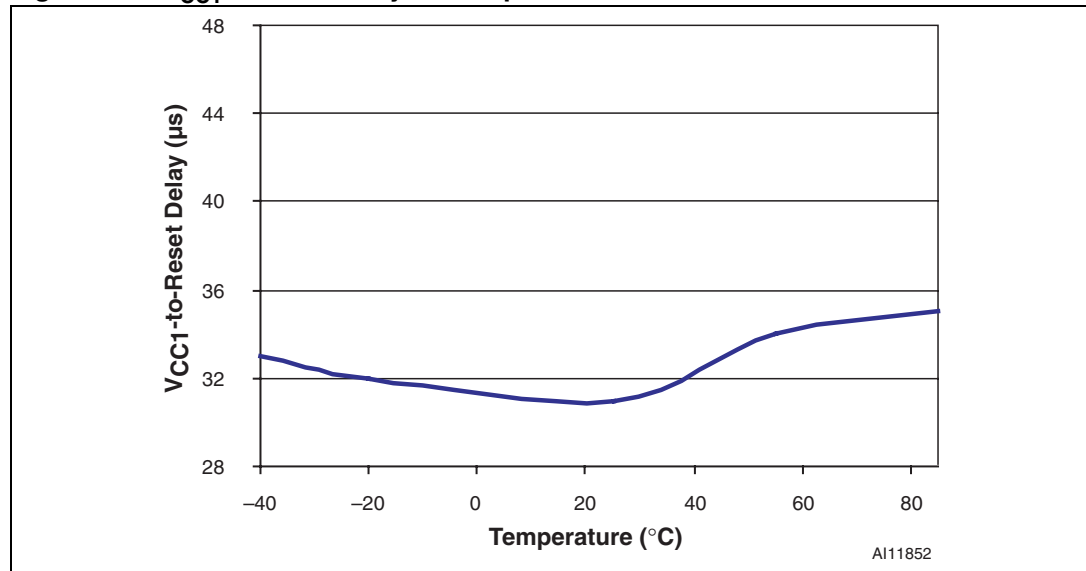


Figure 23. Reset input-to-reset output delay vs. temperature

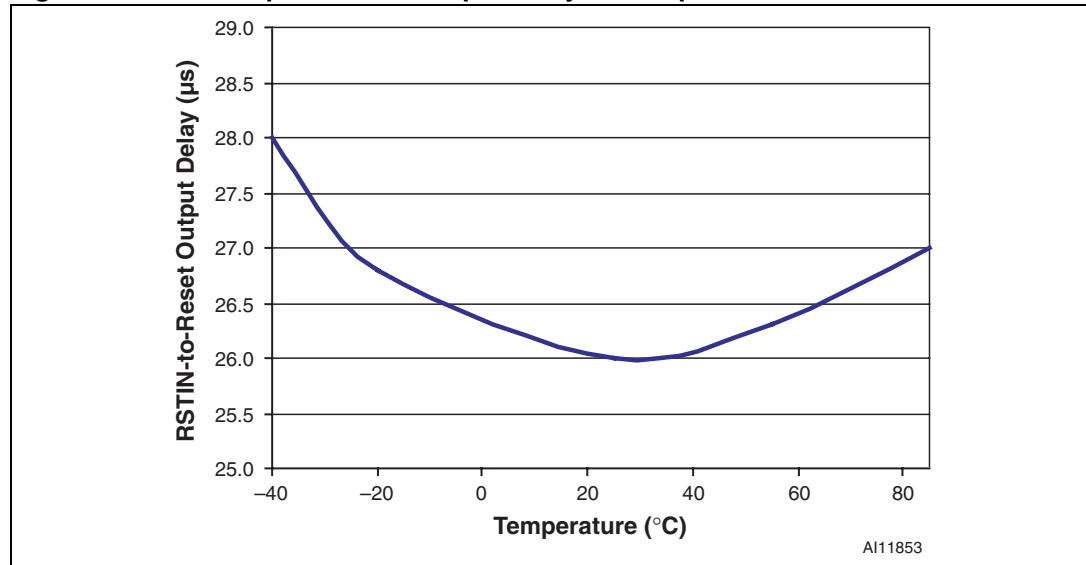
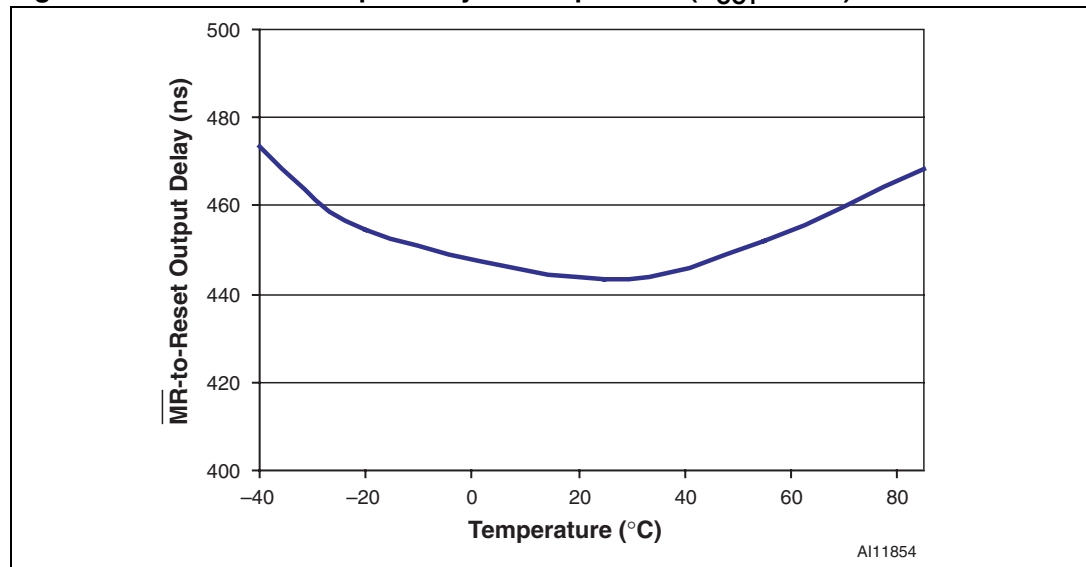


Figure 24. MR-to-reset output delay vs. temperature (V<sub>CC1</sub> = 3.6V)





## Maximum rating

Stressing the device above the rating listed in the Absolute Maximum Ratings” table may cause permanent damage to the device. These are stress ratings only and operation of the device at these or any other conditions above those indicated in the Operating sections of this specification is not implied. Exposure to Absolute Maximum Rating conditions for extended periods may affect device reliability. Refer also to the STMicroelectronics SURE Program and other relevant quality documents.

**Table 4. Absolute maximum ratings**

Symbol	Parameter	Value	Unit
$T_{STG}$	Storage temperature ( $V_{CC}$ Off)	-55 to 150	°C
$T_{SLD}^{(1)}$	Lead solder temperature for 10 seconds	260	°C
$V_{IO}$	Input or output voltage	-0.3 to $V_{CC1} + 0.3$	V
		-0.3 to $V_{CC2} + 0.3$	V
$V_{CC1}, V_{CC2}$	Supply voltage	-0.3 to 7.0	V
$I_{IO}$	Input or output current (all pins)	20	mA
$P_D$	Power dissipation	SOT23-5	654
		SOT23-6	675

*Note:* Reflow at peak temperature of 255°C to 260°C for < 30 seconds (total thermal budget not to exceed 180°C for between 90 to 150 seconds).

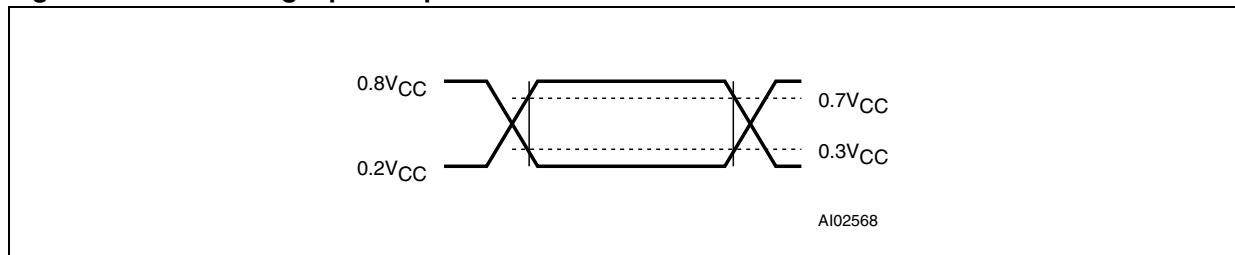
## DC and AC parameters

This section summarizes the operating measurement conditions, and the DC and AC characteristics of the device. The parameters in the DC and AC characteristics Tables that follow, are derived from tests performed under the Measurement Conditions summarized in [Table 5](#), Operating and AC Measurement Conditions. Designers should check that the operating conditions in their circuit match the operating conditions when relying on the quoted parameters.

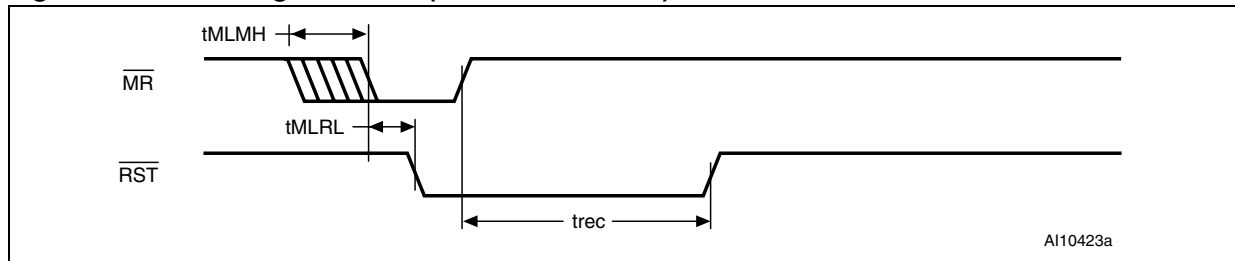
**Table 5. Operating and AC measurement conditions**

Parameter	STM67xx	Unit
V <sub>CC</sub> supply voltage	0.8 to 5.5	V
Ambient operating temperature (T <sub>A</sub> )	-40 to 85	°C
Input rise and fall times	≤ 5	ns
Input pulse voltages	0.2 to 0.8V <sub>CC</sub>	V
Input and output timing ref. voltages	0.3 to 0.7V <sub>CC</sub>	V

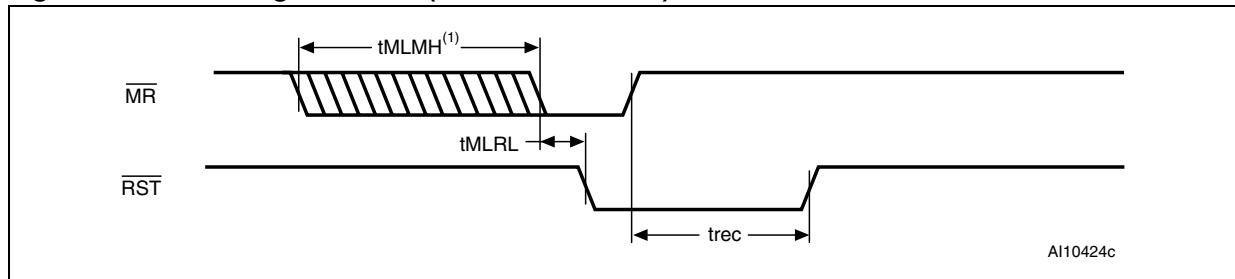
**Figure 25. AC Testing Input/Output Waveforms**



**Figure 26. MR timing waveform (STM6717/18/19/20)**



**Figure 27. MR timing waveform (STM6777/78/79/80)**



1. By connecting a certain capacitor between the MRC pin and V<sub>SS</sub>, the RST can be delayed from 6μs or more (t<sub>MLMH</sub><sup>(1)</sup>, see [Table 7 on page 21](#)).

Table 6. DC and AC characteristics

Sym	Alternative	Description	Test Condition <sup>(1)</sup>	Min	Typ	Max	Unit
V <sub>CC</sub>		Operating voltage		0.8		5.5	V
I <sub>CC1</sub>		V <sub>CC1</sub> supply current	V <sub>CC1</sub> < 5.5V, all I/O pins open		12	35	μA
			V <sub>CC1</sub> < 3.6V, all I/O pins open		8	23	μA
I <sub>CC2</sub>		V <sub>CC2</sub> supply current	V <sub>CC2</sub> < 3.6V, all I/O pins open		3	9	μA
			V <sub>CC2</sub> < 2.75V, all I/O pins open		2.5	7	μA
I <sub>LI</sub> <sup>(2)</sup>		Input leakage current	0V = V <sub>IN</sub> = V <sub>CC</sub>	-1		+1	μA
I <sub>LO</sub>		Open drain $\overline{\text{RST}}$ output leakage current	V <sub>CC1</sub> > V <sub>RST1</sub> , V <sub>CC2</sub> > V <sub>RST2</sub> ; $\overline{\text{RST}}$ not asserted			0.5	μA
V <sub>OL</sub>		Output low voltage ( $\overline{\text{RST}}$ ; push-pull or open drain)	V <sub>CC1</sub> or V <sub>CC2</sub> ≥ 0.8V, I <sub>SINK</sub> = 1μA, $\overline{\text{RST}}$ asserted			0.3	V
			V <sub>CC1</sub> or V <sub>CC2</sub> ≥ 1.0V, I <sub>SINK</sub> = 50μA, $\overline{\text{RST}}$ asserted			0.3	V
			V <sub>CC1</sub> or V <sub>CC2</sub> ≥ 1.2V, I <sub>SINK</sub> = 100μA, $\overline{\text{RST}}$ asserted			0.3	V
			V <sub>CC1</sub> or V <sub>CC2</sub> ≥ 2.7V, I <sub>SINK</sub> = 1.2mA, $\overline{\text{RST}}$ asserted			0.3	V
			V <sub>CC1</sub> or V <sub>CC2</sub> ≥ 4.5V, I <sub>SINK</sub> = 3.2mA, $\overline{\text{RST}}$ asserted			0.4	V
V <sub>OH</sub>		Output high voltage ( $\overline{\text{RST}}$ ; push-pull only)	V <sub>CC1</sub> ≥ 1.8V, I <sub>SOURCE</sub> = 200μA, $\overline{\text{RST}}$ not asserted	0.8V <sub>CC1</sub>			V
			V <sub>CC1</sub> ≥ 2.7V, I <sub>SOURCE</sub> = 500μA, $\overline{\text{RST}}$ not asserted	0.8V <sub>CC1</sub>			V
			V <sub>CC1</sub> ≥ 4.5V, I <sub>SOURCE</sub> = 800μA, $\overline{\text{RST}}$ not asserted	0.8V <sub>CC1</sub>			V
t <sub>R</sub> <sup>(3)</sup>		Push-pull RST rise time (STM6718/20/78/80)	Rise time measured from 10% to 90% of V <sub>CC</sub> ; C <sub>L</sub> = 5pF, V <sub>CC</sub> = 3.3V		5	25	ns
Reset thresholds							
V <sub>RST</sub> <sup>(4)</sup>	V <sub>TH1</sub>	V <sub>CC1</sub> reset threshold	L (falling)	4.500	4.625	4.750	V
			M (falling)	4.250	4.375	4.500	V
			T (falling)	3.000	3.075	3.150	V
			S (falling)	2.850	2.925	3.000	V
			R (falling)	2.550	2.625	2.700	V
			Z (falling)	2.250	2.313	2.375	V
			Y (falling)	2.125	2.188	2.250	V
			W (falling)	1.620	1.665	1.710	V
V (falling)	1.530	1.575	1.620	V			

Table 6. DC and AC characteristics (continued)

Sym	Alternative	Description	Test Condition <sup>(1)</sup>	Min	Typ	Max	Unit
$V_{RST2}^{(4)}$	$V_{TH2}$	$V_{CC2}$ reset threshold	T (falling)	3.000	3.075	3.150	V
			S (falling)	2.850	2.925	3.000	V
			R (falling)	2.550	2.625	2.700	V
			Z (falling)	2.250	2.313	2.375	V
			Y (falling)	2.125	2.188	2.250	V
			W (falling)	1.620	1.665	1.710	V
			V (falling)	1.530	1.575	1.620	V
			I (falling)	1.350	1.388	1.425	V
			H (falling)	1.275	1.313	1.350	V
			G (falling)	1.080	1.110	1.140	V
			F (falling)	1.020	1.050	1.080	V
			K (falling)	0.895	0.925	0.955	V
			J (falling)	0.845	0.875	0.905	V
			E (falling)	0.810	0.833	0.855	V
D (falling)	0.765	0.788	0.810	V			
$V_{HYST}$		Reset threshold hysteresis	Referenced to $V_{RST}$ typical		0.5		%
$t_{RD}$		$V_{CC}$ to $\overline{RST}$ delay	$V_{CC1} = (V_{RST1} + 100mV)$ to $(V_{RST} - 100mV)$		20		$\mu s$
			$V_{CC2} = (V_{RST2} + 75mV)$ to $(V_{RST2} - 75mV)$		20		$\mu s$
$t_{rec}$	$t_{RP}$	$\overline{RST}$ time-out period		140	210	280	ms
Adjustable reset comparator input (STM6719/20/79/80)							
$V_{RSTIN}$		RSTIN input threshold		611	626.5	642	mV
$I_{RSTIN}$		RSTIN input current		-25		+25	nA
		RSTIN hysteresis			3		mV
$t_{RSTIND}$		RSTIN to $\overline{RST}$ output delay	$V_{RSTIN}$ to $(V_{RSTIN} - 30mV)$		22		$\mu s$

Table 6. DC and AC characteristics (continued)

Sym	Alternative	Description	Test Condition <sup>(1)</sup>	Min	Typ	Max	Unit
Manual (push-button) reset input							
$V_{IL}$		$\overline{MR}$ input voltage				$0.3V_{CC1}$	V
$V_{IH}$				$0.7V_{CC1}$			V
$t_{MLMH}$	$t_{MR}$	$\overline{MR}$ minimum pulse width (STM6717/18/19/20)		1			$\mu s$
		$\overline{MR}$ minimum pulse width (STM6777/78/79/80)	MRC connected via capacitor to $V_{SS}$ <sup>(5)</sup>		6		$\mu s$
$t_{MLRL}$	$t_{MRD}$	$\overline{MR}$ to $\overline{RST}$ output delay			200		ns
		$\overline{MR}$ glitch immunity (STM6717/18/19/20)			100		ns
		$\overline{MR}$ pull-up resistance		25	50	80	k $\Omega$

- Valid for ambient operating temperature:  $T_A = -40$  to  $85^\circ C$ ;  $V_{CC1} = 0.8$  to  $5.5V$  and  $V_{CC2} = 0.8$  to  $3.6V$  (except where noted).
- Input leakage for the MRC pin is not tested.
- Guaranteed by design.
- The leakage current measured on the  $\overline{RST}$  pin is tested with the reset de-asserted (output high impedance).
- Selecting the appropriate external capacitor (preferably less than  $100pF$ ) allows systems designers to vary the minimum delay from  $6\mu s$  (MRC pin left open) or more (see Table 7).

Table 7.  $t_{MLMH}$  Minimum pulse width

$V_{CC1}$	Capacitor value <sup>(1)</sup>					
	100pF	0.1 $\mu F$	2.2 $\mu F$	3.3 $\mu F$	4.7 $\mu F$	6.8 $\mu F$
1.6V	120 $\mu s$	120ms	2.6s	4.0s	5.6s	8.2s
2.0V	122 $\mu s$	122ms	2.7s	4.0s	5.8s	8.3s
3.0V	125 $\mu s$	125ms	2.7s	4.1s	5.9s	8.5s
4.0V	128 $\mu s$	129ms	2.8s	4.2s	6.0s	8.7s
5.0V	130 $\mu s$	130ms	2.8s	4.3s	6.1s	8.8s

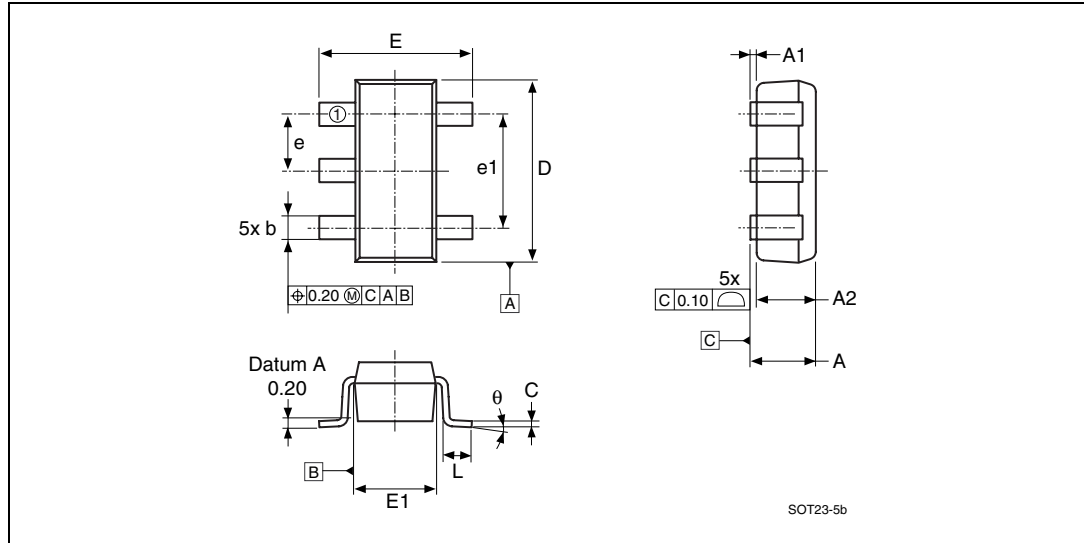
- At  $25^\circ C$  (typical)

# Package mechanical data

In order to meet environmental requirements, ST offers these devices in ECOPACK<sup>®</sup> packages. These packages have a Lead-free second level interconnect. The category of second Level Interconnect is marked on the package and on the inner box label, in compliance with JEDEC Standard JESD97.

The maximum ratings related to soldering conditions are also marked on the inner box label. ECOPACK is an ST trademark. ECOPACK specifications are available at: [www.st.com](http://www.st.com).

**Figure 28. SOT23-5 – 5-lead small outline transistor package mechanical drawing**



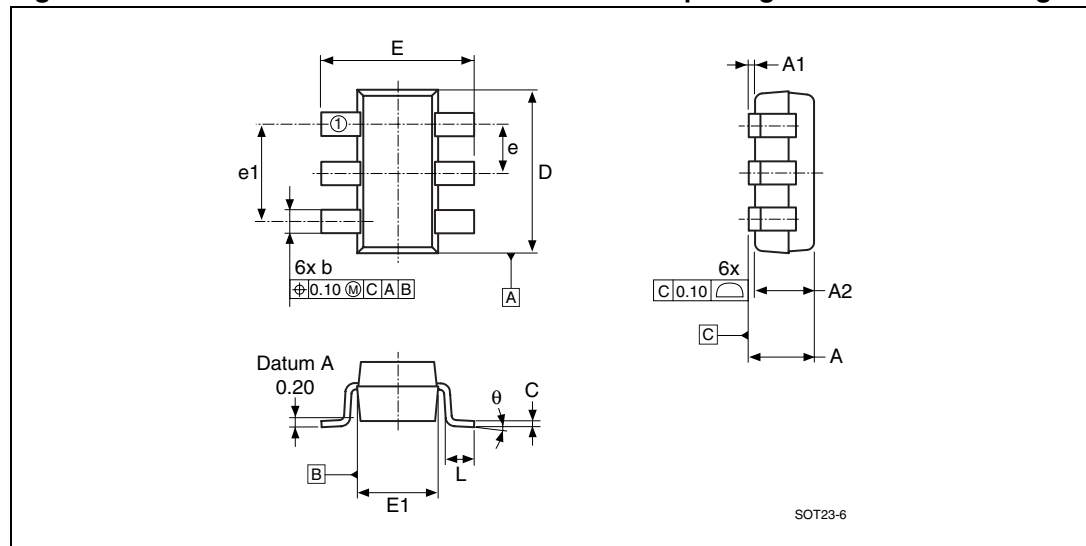
*Note: Drawing is not to scale.*

**Table 8. SOT23-5 – 5-lead small outline transistor package mechanical data**

Symb	mm			inches		
	Typ	Min	Max	Typ	Min	Max
A	–	–	1.45	–	–	0.057
A1	–	–	0.15	–	–	0.006
A2	1.15	0.90	1.30	0.045	0.035	0.051
b	–	0.30	0.50	–	0.012	0.020
C	–	0.08	0.22	–	0.003	0.009
D	2.90	–	–	0.114	–	–
E	2.80	–	–	0.110	–	–
E1	1.60	–	–	0.063	–	–
e	0.95	–	–	0.037	–	–
e1	1.90	–	–	0.075	–	–
L	0.45	0.30	0.60	0.018	0.012	0.024
Q	4°	0°	8°	4°	0°	8°
N	5			5		

Note: Dimensions per JEDEC SOT/SOP Product Outline MO-178C, variation AA

**Figure 29. SOT23-6 – 6-lead small outline transistor package mechanical drawing**



Note: Drawing is not to scale.

**Table 9. SOT23-6 – 6-lead small outline transistor package mechanical data**

Symb	mm			inches		
	Typ	Min	Max	Typ	Min	Max
A	–	–	1.45	–	–	0.057
A1	–	–	0.15	–	–	0.006
A2	1.15	0.90	1.30	0.045	0.035	0.051
b	–	0.30	0.50	–	0.012	0.020
C	–	0.08	0.22	–	0.003	0.009
D	2.90	–	–	0.114	–	–
E	2.80	–	–	0.110	–	–
E1	1.60	–	–	0.063	–	–
e	0.95	–	–	0.037	–	–
e1	1.90	–	–	0.075	–	–
L	0.45	0.30	0.60	0.018	0.012	0.024
Q	4°	0°	8°	4°	0°	8°
N	6			6		

*Note:* Dimensions per JEDEC SOT/SOP product outline MO-178C variation AA



## Part numbering

**Table 10. Ordering information scheme**

Example:	STM67xx	LT	WY	6	E
<b>Device Type</b>					
STM67xx					
<b>Reset Thresholds (<math>V_{RST1}</math> and <math>V_{RST2}</math>) for <math>V_{CC1}</math> and <math>V_{CC2}</math></b>					
<b>STM6717/18/19/20/77/78 (<math>V_{RST1}</math> and <math>V_{RST2}</math>)</b>					
Suffix	$V_{RST1}$	$V_{RST2}$			
LT	4.625	3.075			
MS	4.375	2.925			
MR	4.375	2.625			
TZ <sup>(1)</sup>	3.075	2.313			
TW <sup>(1)</sup>	3.075	1.665			
TI	3.075	1.388			
TG <sup>(1)</sup>	3.075	1.110			
TK	3.075	0.925			
TE	3.075	0.833			
SY <sup>(1)</sup>	2.925	2.188			
SV <sup>(1)</sup>	2.925	1.575			
SH	2.925	1.313			
SF <sup>(1)</sup>	2.925	1.050			
SJ	2.925	0.875			
SD	2.925	0.788			
YV	2.188	1.575			
YH	2.188	1.313			
YF	2.188	1.050			
YJ	2.188	0.875			
YD	2.188	0.788			
VH	1.575	1.313			
VF	1.575	1.050			
VJ	1.575	0.875			
VD	1.575	0.788			
<b>STM6779/80 (<math>V_{RST1}</math> only)</b>					
L-	4.625	-			
T-	3.075	-			
S-	2.925	-			
Y-	2.188	-			
V-	1.575	-			
R-	2.625	-			
Z-	2.313	-			
<b>Package</b>					
WY = SOT23-5					
WB = SOT23-6					
<b>Temperature Range</b>					
6 = -40 to 85°C					
<b>Shipping Method</b>					
E = ECOPACK Package, Tubes					
F = ECOPACK Package, Tape & Reel					

1. These are standard versions and are typically held in stock. A non-standard version may require a higher minimum volumes, and/or longer delivery times. For other options, or for more information on any aspect of this device, please contact the ST Sales Office nearest you

## Revision history

**Table 11. Document revision history**

Date	Version	Revision details
18-Oct-2004	1.0	First draft
25-Oct-2004	1.1	Descriptive text, sales types ( <a href="#">Table 10</a> )
14-Jan-2005	1.2	Update characteristics, pin functions ( <a href="#">Table 2</a> )
09-Feb-2005	1.3	Update characteristics ( <a href="#">Figure 9</a> ; <a href="#">Table 3</a> )
08-Apr-2005	1.4	Update characteristics and mechanical dimensions; add table ( <a href="#">Figure 9</a> , <a href="#">10</a> , <a href="#">27</a> , <a href="#">28</a> , <a href="#">29</a> ; <a href="#">Table 4</a> , <a href="#">6</a> , <a href="#">10</a> , <a href="#">8</a> , <a href="#">9</a> )
28-Jul-2005	1.5	Update characteristics, reset delay ( <a href="#">Figure 10</a> , <a href="#">27</a> ; <a href="#">Table 4</a> , <a href="#">6</a> , <a href="#">7</a> , <a href="#">10</a> )
13-Sep-2005	2.0	Add operating characteristics; update timings, document status, Lead-free text ( <a href="#">Figure 13</a> , <a href="#">14</a> , <a href="#">15</a> , <a href="#">16</a> , <a href="#">17</a> , <a href="#">18</a> , <a href="#">19</a> , <a href="#">20</a> , <a href="#">21</a> , <a href="#">22</a> , <a href="#">23</a> , <a href="#">24</a> , <a href="#">26</a> , <a href="#">27</a> ; <a href="#">Table 10</a> )
07-Oct-2005	3.0	Marked STM6779/6780 as availability request parts ( <a href="#">Table 1</a> , <a href="#">10</a> )
07-Feb-2007	4.0	Update STM6779/6780 availability (cover page, <a href="#">Table 1</a> , <a href="#">10</a> )

**Please Read Carefully:**

Information in this document is provided solely in connection with ST products. STMicroelectronics NV and its subsidiaries ("ST") reserve the right to make changes, corrections, modifications or improvements, to this document, and the products and services described herein at any time, without notice.

All ST products are sold pursuant to ST's terms and conditions of sale.

Purchasers are solely responsible for the choice, selection and use of the ST products and services described herein, and ST assumes no liability whatsoever relating to the choice, selection or use of the ST products and services described herein.

No license, express or implied, by estoppel or otherwise, to any intellectual property rights is granted under this document. If any part of this document refers to any third party products or services it shall not be deemed a license grant by ST for the use of such third party products or services, or any intellectual property contained therein or considered as a warranty covering the use in any manner whatsoever of such third party products or services or any intellectual property contained therein.

**UNLESS OTHERWISE SET FORTH IN ST'S TERMS AND CONDITIONS OF SALE ST DISCLAIMS ANY EXPRESS OR IMPLIED WARRANTY WITH RESPECT TO THE USE AND/OR SALE OF ST PRODUCTS INCLUDING WITHOUT LIMITATION IMPLIED WARRANTIES OF MERCHANTABILITY, FITNESS FOR A PARTICULAR PURPOSE (AND THEIR EQUIVALENTS UNDER THE LAWS OF ANY JURISDICTION), OR INFRINGEMENT OF ANY PATENT, COPYRIGHT OR OTHER INTELLECTUAL PROPERTY RIGHT.**

**UNLESS EXPRESSLY APPROVED IN WRITING BY AN AUTHORIZED ST REPRESENTATIVE, ST PRODUCTS ARE NOT RECOMMENDED, AUTHORIZED OR WARRANTED FOR USE IN MILITARY, AIR CRAFT, SPACE, LIFE SAVING, OR LIFE SUSTAINING APPLICATIONS, NOR IN PRODUCTS OR SYSTEMS WHERE FAILURE OR MALFUNCTION MAY RESULT IN PERSONAL INJURY, DEATH, OR SEVERE PROPERTY OR ENVIRONMENTAL DAMAGE. ST PRODUCTS WHICH ARE NOT SPECIFIED AS "AUTOMOTIVE GRADE" MAY ONLY BE USED IN AUTOMOTIVE APPLICATIONS AT USER'S OWN RISK.**

Resale of ST products with provisions different from the statements and/or technical features set forth in this document shall immediately void any warranty granted by ST for the ST product or service described herein and shall not create or extend in any manner whatsoever, any liability of ST.

ST and the ST logo are trademarks or registered trademarks of ST in various countries.

Information in this document supersedes and replaces all information previously supplied.

The ST logo is a registered trademark of STMicroelectronics. All other names are the property of their respective owners.

© 2007 STMicroelectronics - All rights reserved

STMicroelectronics group of companies

Australia - Belgium - Brazil - Canada - China - Czech Republic - Finland - France - Germany - Hong Kong - India - Israel - Italy - Japan - Malaysia - Malta - Morocco - Singapore - Spain - Sweden - Switzerland - United Kingdom - United States of America

[www.st.com](http://www.st.com)

