



Product Description

The Sirenza Microdevices' STQ-1016 is a direct quadrature modulator targeted for use in a wide range of communications systems, including cellular/PCS, GSM, CDMA, TETRA, and ISM datacom. This device features a wide 250 - 1000 MHz operating frequency band, excellent carrier and sideband suppression, and a low broadband noise floor.

The STQ-1016 uses silicon germanium (SiGe) device technology and delivers a typical output power of -9 dBm with greater than 60dB IM3 suppression. A digital input shut-down feature is included that, when enabled, attenuates the output by 60dB. The device is packaged in an industry standard 16 pin TSSOP with exposed paddle for superb RF and thermal ground.

Functional Block Diagram

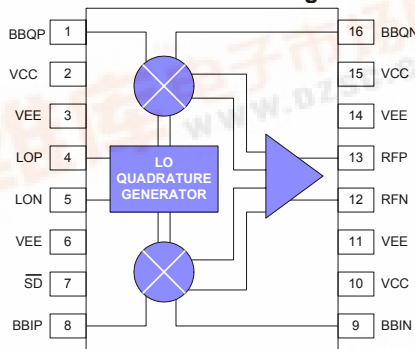

Product Specifications – RF Output: $T_A = 25^\circ\text{C}$

Parameters	Test Conditions (see page 2)	Units	Min.	Typ.	Max.
RF Frequency Range		MHz	250		1000
Output Power	(baseband input level 600 mVp-p differential)	dBm	-12.0	-9	-7
RF Port Return Loss	matched to 50Ω using schematic shown on page 5	dB		>10, 250 to 1000 MHz >15, 275 to 500 MHz	
Output P1dB	(baseband input level 3.8Vp-p differential typical)	dBm	+3	+6	
Carrier Feedthrough		dBm		-38	-30
Sideband Suppression		dB	34	42	
IM3 Suppression	2-tone BB input @ 600mVp-p diff. per tone, 20kHz spacing	dB	58	62	
Broadband Noise Floor	baseband inputs tied to 1.9V _{DC} , -20MHz offset from carrier	dBm/Hz		-154	
Quadrature Phase Error		deg	-2	±0.5	+2
I/Q Amplitude Balance		dB	-0.2	±0.05	+0.2
Supply Voltage (Vcc)		V	+4.75	+5	+5.25
Supply Current		mA		80	86
Device Thermal Resistance	junction-case	°C/W		25	

Performance tests and ratings for Sirenza Microdevices' products were performed internally by Sirenza and measured using specific computer systems and/or components and reflect the approximate performance of the products as measured by those tests. Any difference in circuit implementation, test software, or test equipment may affect actual performance. The information provided herein is believed to be reliable at press time and Sirenza Microdevices assumes no responsibility for the use of this information. All such use shall be entirely at the user's own risk. Prices and specifications for Sirenza Microdevices' products are subject to change without notice. Buyers should consult Sirenza Microdevices' standard terms and conditions of sale for Sirenza's limited warranty with regard to its products. No patent rights or licenses to any of the circuits described herein are implied or granted to any third party. Sirenza Microdevices does not authorize or warrant any product for use in life-support devices and/or systems. Copyright 2004 Sirenza Microdevices, Inc. All worldwide rights reserved.

STQ-1016

250 - 1000 MHz Direct Quadrature Modulator



16 pin TSSOP with Exposed Ground Pad
Package Footprint: 0.197 x 0.252 inches, (5.0 x 6.4 mm)
Package Height: 0.039 inches (1.0 mm)

Product Features

- Excellent carrier feedthrough, -38 dBm constant over output power
- Output P1dB +5dBm
- Very low noise floor, -154 dBm/Hz typical
- Wide baseband input, DC - 500 MHz
- Superb phase accuracy and amplitude balance, ±0.5 deg./±0.2 dB
- Low LO drive requirement, -5 dBm

Applications

- Cellular/PCS/GSM/CDMA transceivers
- TETRA
- GMSK, QPSK, QAM, SSB modulators





STQ-1016 Direct Quadrature Modulator

Test Conditions

(for all product specification tables unless otherwise noted)

V _{CC} (pins 2,10,15)	+5V
T _A	+25°C
Baseband Input (Pins 1, 8, 9, 16)	1.9V DC bias, 200kHz frequency, 300mVp-p per pin = 600mVp-p differential drive, I and Q signals in quadrature
LO Input (Pins 4, 5)	-5dBm @ 250 to 1000 MHz

Product Specifications - Baseband Modulation Input: T_A = 25°C

Parameters	Additional Test Conditions	Unit	Min.	Typ.	Max.
Baseband Frequency Input	-3dB bandwidth, baseband inputs terminated in 50 ohms	MHz	DC		500
Baseband Input Resistance	per pin	kohms		4.4	
Baseband Input Capacitance	per pin	pF		0.5	

Product Specifications - LO Input: T_A = 25°C

Parameters	Additional Test Conditions	Unit	Min.	Typ.	Max.
LO Frequency		MHz	250		1000
LO Drive Level		dBm	-8	-5	-2
LO Port Return Loss	matched to 50Ω using schematic shown on page 5	dB		>10, 250 to 1000 MHz >15, 275 to 500 MHz	

Product Specifications – Miscellaneous: T_A = 25°C

Parameters	Additional Test Conditions	Unit	Min.	Typ.	Max.
Shut-Down Supply Current	Shut-down enabled	mA		45	60
Shut-Down Attenuation		dB		60	
Shut-Down Pin Resistance	@ 1MHz	kohm		11.9	
Shut-Down Pin Capacitance	@ 1MHz	pF		5.2	
Shut-down Control Voltage Thresholds	Shut-down disabled (normal operation)	V	3.75		V _{CC}
	Shut-down enabled	V	0.0		1.5
Shut-Down Settling Time		ns		<450	



STQ-1016 Direct Quadrature Modulator

250 - 1000 MHz Typical Device Performance

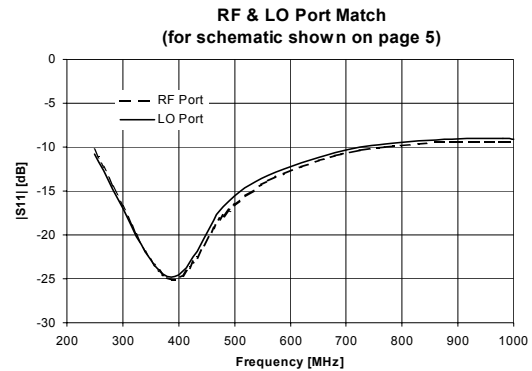
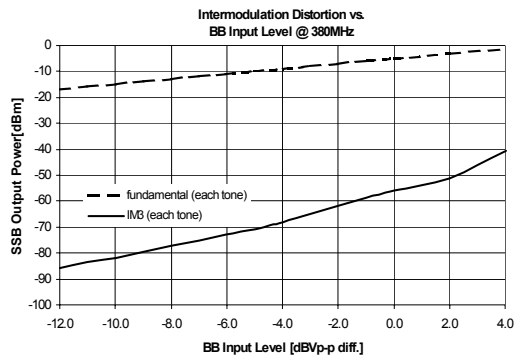
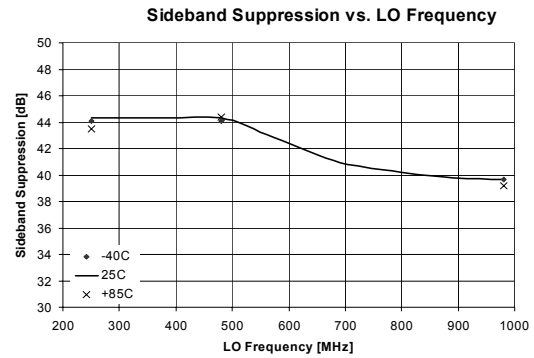
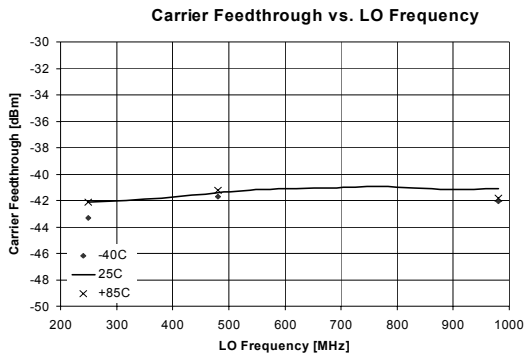
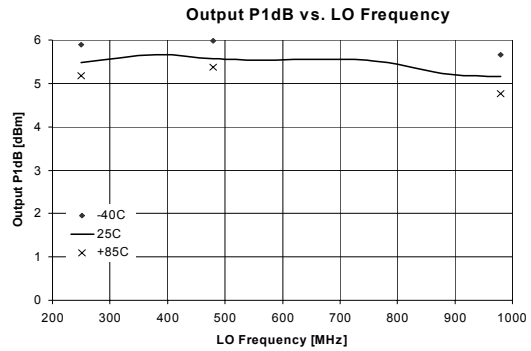
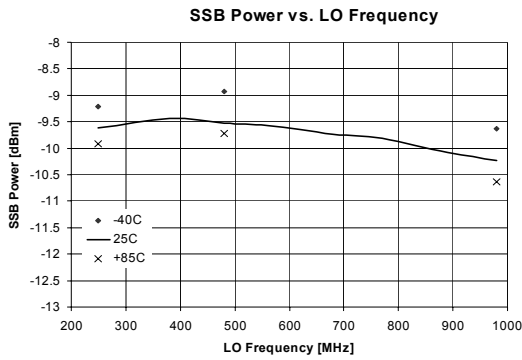



STQ-1016 Direct Quadrature Modulator

Package Dimensions ("16" Package)

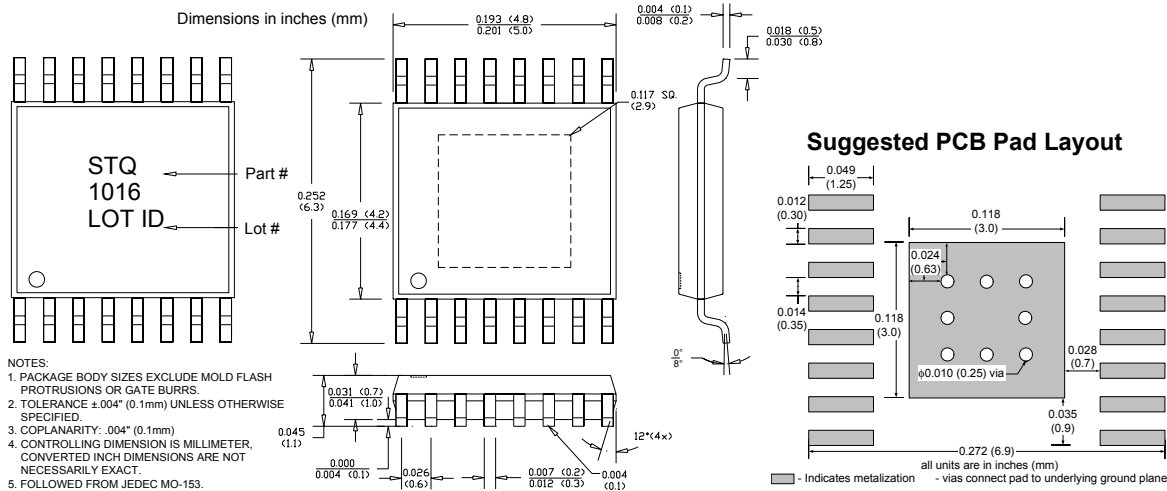

Pin Out Description

Pin #	Function	Description	Additional Comments
1	BBQP	Q-channel baseband input, positive terminal	Nominal DC bias voltage is 1.9V (biased internally)
2	VCC	Positive supply (+5V)	
3	VEE	Ground	
4	LOP	Local oscillator input, positive terminal	Nominal DC voltage is 2.0V. Input should be AC-coupled.
5	LON	Local oscillator input, negative terminal	Nominal DC voltage is 2.0V. Input should be AC-coupled.
6	VEE	Ground	
7	SD	Shut-down control	Logic high = normal operation; logic low = shut-down enabled.
8	BBIP	I-channel baseband input, positive terminal	Nominal DC bias voltage is 1.9V (biased internally)
9	BBIN	I-channel baseband input, negative terminal	Nominal DC bias voltage is 1.9V (biased internally)
10	VCC	Positive supply (+5V)	
11	VEE	Ground	
12	RFN	RF output, negative terminal	Nominal DC voltage is 2.4V. Output should be AC-coupled.
13	RFP	RF output, positive terminal	Nominal DC voltage is 2.4V. Output should be AC-coupled.
14	VEE	Ground	
15	VCC	Positive supply (+5V)	
16	BBQN	Q-channel baseband input, negative terminal	Nominal DC bias voltage is 1.9V (biased internally)

Absolute Maximum Ratings

Parameters	Value	Unit
Supply Voltage (VCC)	6.0	V _{DC}
LO, RF Input (LOP, LON, RFP, RFN)	+10	dBm
Baseband Min Input Voltage (BBIP, BBIN, BBQP, BBQN)	0	V _{DC}
Baseband Max Input Voltage (BBIP, BBIN, BBQP, BBQN)	3	V _{DC}
Operating Temperature	-40 to +85	°C
Storage Temperature	-65 to +150	°C

Operation of this device beyond any one of these limits may cause permanent damage. For reliable continuous operation the device voltage and current must not exceed the maximum operating values specified in the table on page one.

Part Number Ordering Information

Part Number	Reel Size	Devices/Reel	
		Min.	Max.
STQ-1016	7"	500	1000

Moisture Sensitivity Level 1 - no special handling required.



Caution: ESD Sensitive

Appropriate precaution in handling, packaging and testing devices must be observed.

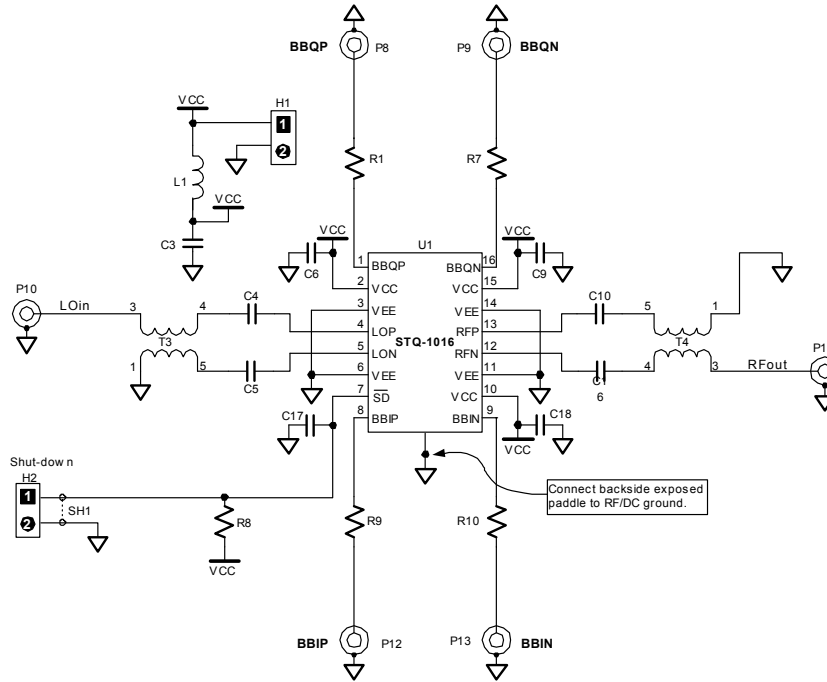

Bill of Materials (for 250 – 1000 MHz Evaluation Board P/N STQ1016EVB)

Component Designator	Value	Qty	Vendor	Part Number	Description
U1		1	SMDI	STQ-1016	SiGe Direct Quadrature Modulator
P8, P9, P10, P11, P12, P13		6	Johnson Components	142-0701-851	SMA connector, end launch with tab, for .062" thick board
H1, H2		2	AMP	640453-2	2-pin header, right angle
T3, T4	1:1	2	M/A COM	ETC1-1-13	RF transformer, 4.5 - 3000MHz
L1	1uH	1	Panasonic	ELJ-FA1R0KF2	Inductor, 1210 footprint, ±10% tolerance
R1, R7, R9, R10	200 ohm	4	Venkel	CR1206-8W-2000T	Resistor, 1206 footprint, ±1% tolerance
R8	1 kohm	1	Venkel	CR0603-16W-1001FT	Resistor, 0603 footprint, ±1% tolerance
C6, C18	33pF	2	Venkel	C0603COG500-330JNE	Capacitor, 0603 footprint, COG dielectric, ±5% tolerance
C9, C17	1nF	2	Venkel	C0603COG500-102JNE	Capacitor, 0603 footprint, COG dielectric, ±5% tolerance
C3	2.2uF	1	Venkel	C1206Y5V160-225ZNE	Capacitor, 1206 footprint, Y5V dielectric, 16V rating
C4, C5, C10, C16	22pF	4	Venkel	C0603COG500-220JNE	Capacitor, 0603 footprint, COG dielectric, ±5% tolerance
SH1		1	3M	929950-00	Shunt for 2-pin header

Direct Quadrature Modulator: General Test Set-Up

