

SmartHeat®

**Hand Soldering**

SMT Rework

Desoldering

BGA Rework

CSP Rework

Fume Extraction

Fluid Dispensing

Terms & Conditions

## metcal > products > hand soldering > MX rework systems > STTC tip cartridges

### Most popular standard recommended tip cartridges

These cartridges are Metcal's most popular. Owning these tips will help you to complete almost every soldering task

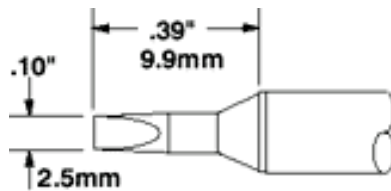

**STTC-X36\***  
Chisel 30° .10" (2.5mm)

For medium to heavy load joints requiring extra reach.

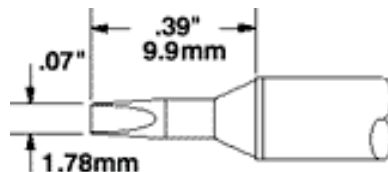

**STTC-X37\***  
Chisel 30° .07" (1.78mm)

For a wide variety of tasks. If you are choosing the first tip for your Metcal system, the STTC-037 is ideal.

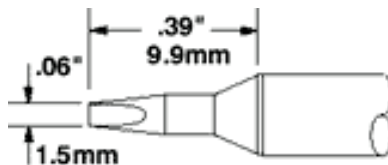

**STTC-X38\***  
Chisel 30° .06" (1.5mm)

A finer version of the STTC-037. Ideal for medium to light through-hole and general surface mount touch-up.

500 series x=5 600 series x=0 700 series x=1 800 series x=8, when followed by an \*

### Other Standard Cartridges

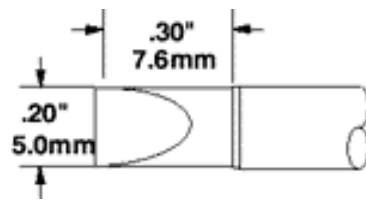

**STTC-X17\***  
Extra Large Chisel  
.20~(5.0mm)

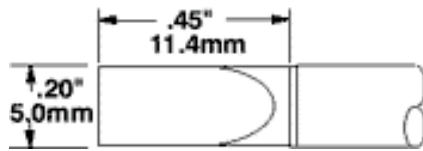

**STTC-X65**  
Large Chisel  
.20~ (5.0mm)

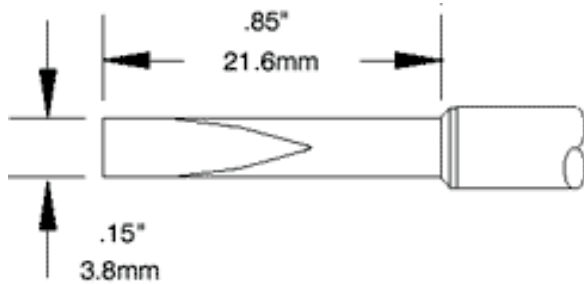

**STTC-X20**  
Long Reach  
Chisel 12°  
.15~ (3.8mm)

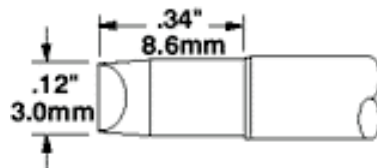
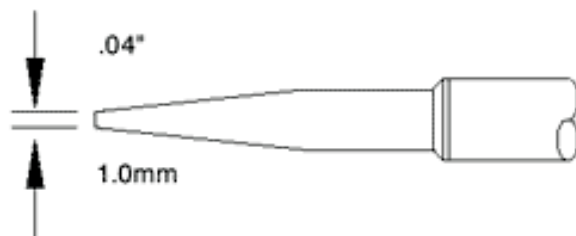

**STTC-X03\***  
Chisel 90°  
.12~ (3.0mm)

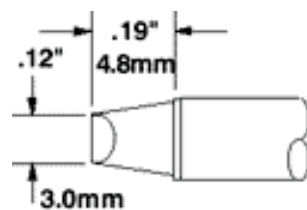

**STTC-X13**  
Chisel 90°  
.12~ (3.0mm)

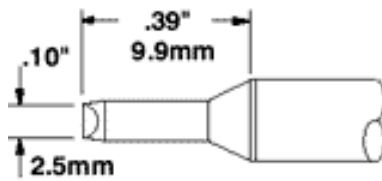

**STTC-X33**  
Chisel 90°  
.10" (2.5mm)

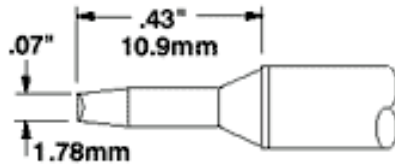

**STTC-X04**  
Chisel 90°  
.07" (1.78mm)

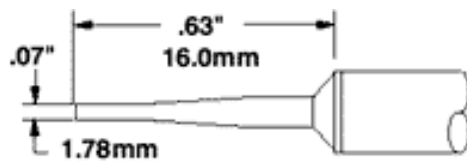

**STTC-X42**  
Long Reach Chisel 60°  
.07" (1.78mm)

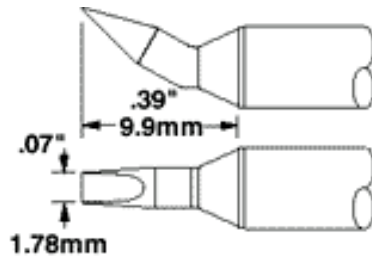

**STTC-X98**  
Chisel Bent 30°  
.07" (1.78mm)

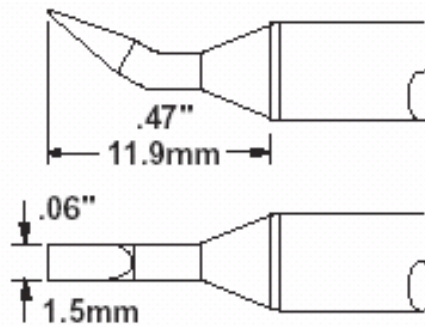

**STTC-X99**  
Chisel Bent 30°  
.06" (1.5mm)

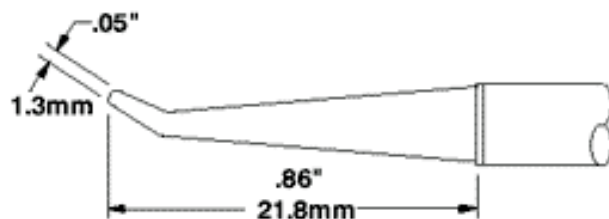

**STTC-X41**  
Chisel 30°  
.05" (1.3mm)

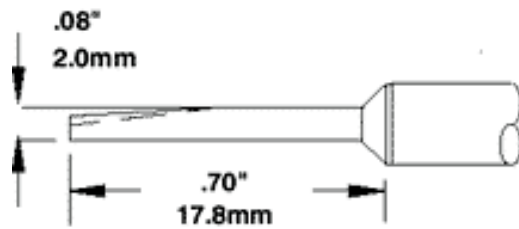

**STTC-X83**  
Conical Grooved  
.08~ (2.0mm)

---

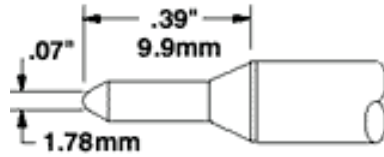

**STTC-X32**  
Conical Sharp  
.07~ (1.78mm)

---

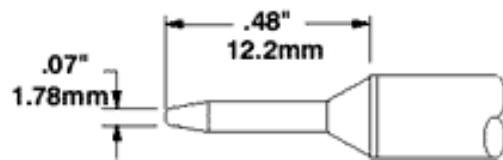

**STTC-X02**  
Conical Sharp  
.07~ (1.78mm)

---

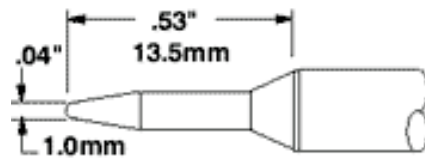

**STTC-X01**  
Conical Sharp  
.04~ (1.0mm)

---

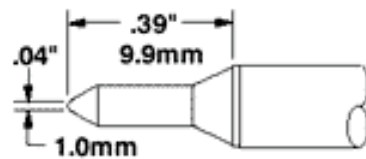

**STTC-X31**  
Conical Sharp  
.04~ (1.0mm)

---

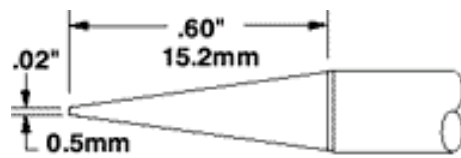

**STTC-X43**  
Conical Sharp  
.02~ (0.5mm)

---

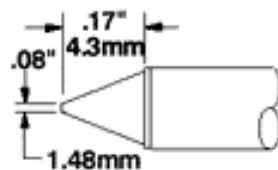

**STTC-X12**  
Conical  
.08~ (2.03mm)

---

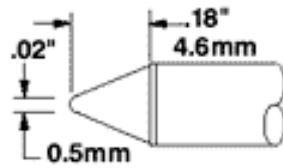

**STTC-X11**  
Conical  
.02~ (0.5mm)

---

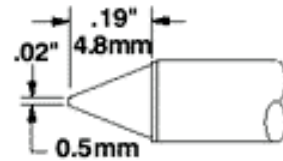

**STTC-X16**  
Conical  
.02~ (0.5mm)

---

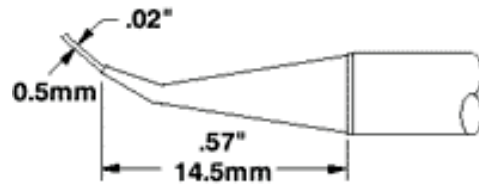

**STTC-X44**  
Sharp Bent 30°  
.02~ (0.5mm)

---

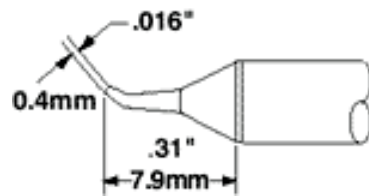

**STTC-X26**  
Sharp Bent 30°  
.016~ (0.4mm)

---

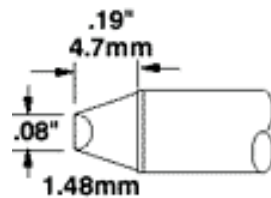

**STTC-X14**  
Bevel 45°  
.08~ (2.03mm)

---

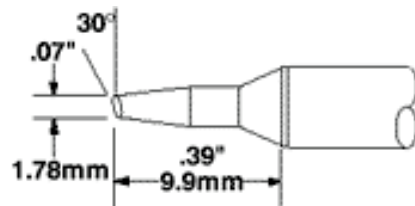

**STTC-X35**  
Bevel 30°  
.07~ (1.78mm)

---

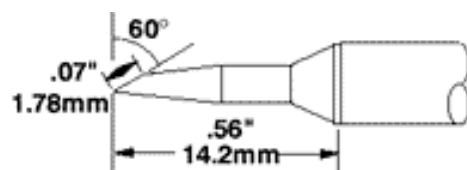

**STTC-X47**  
Bevel 60°  
.07~ (1.78mm)

---

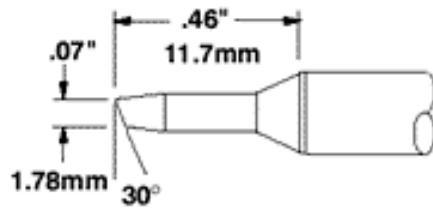

**STTC-X05**  
 Bevel 30°  
 .07" (1.78mm)

### Specialty cartridges

Specialty cartridges are more expensive than Metcal's standard cartridges. If you think that you need a specialty cartridge, you may want to try a standard cartridge first.

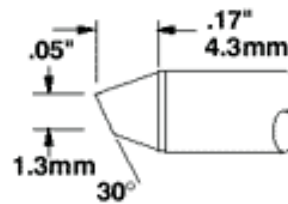

**STTC-X15**  
 Bevel 30°  
 .05" (1.3mm)

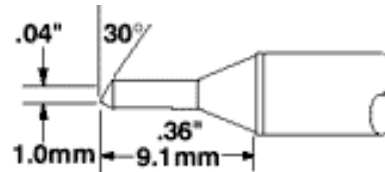

**STTC-X24**  
 Bevel 30°  
 .04" (1.0mm)

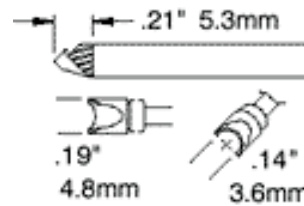

**STTC-X97**  
 Grooved Semi-Rigid  
 Coax

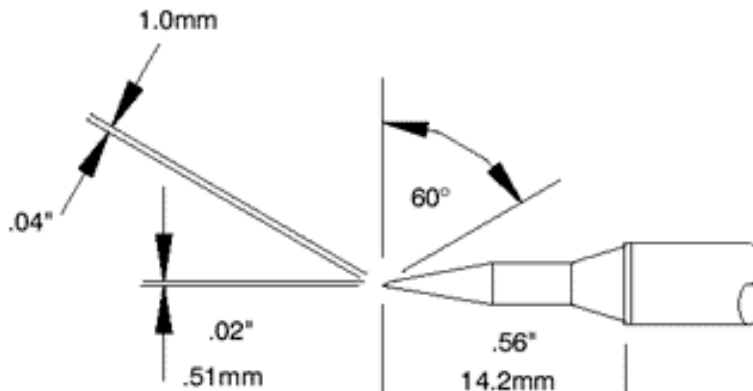

**STTC-X46**  
 Long Reach  
 Bevel 60°  
 .04" (1.0mm)