

M/A-COM GaAs SPDT Switch DC - 3.0 GHz

SW-456

Features

- Low Cost Plastic SC-70 (SOT-363) Package
- Low Insertion Loss < 0.3 dB @ 900 MHz
- Low Power Consumption < 15 μ A @ +2.3 Volts
- Positive or Negative 2.3 to 8 Volt Control

Description

M/A-COM's SW-456 is a GaAs monolithic switch in a low cost SC-70 (SOT-363) surface mount plastic package. The SW-456 is ideally suited for applications where very low power consumption, low insertion loss, very small size and low cost are required. Typical application is in dual band systems where switching between small signal components is required such as filter banks, single-band LNA's, converters, etc. The SW-456 can be used in applications up to 0.25 watts in systems such as cellular, PCS, DCS1800, GSM, CDMA, W-CDMA and other analog/digital wireless communication systems.

The SW-456 is fabricated using a mature 0.8 micron GaAs MESFET process. The process features full passivation for performance and reliability.

Handling Procedures

The following precautions should be observed to avoid damage:

Static Sensitivity

Gallium Arsenide Integrated Circuits are ESD sensitive and can be damaged by static electricity. Proper ESD techniques should be used when handling these devices.

Truth Table

Mode (Control)	V1	V2	RFC - RF1	RFC - RF2
Positive ¹	0 \pm 0.2 V	+2.3 to +8 V	Off	On
	+2.3 to +8 V	0 \pm 0.2 V	On	Off
Negative ²	0 \pm 0.2 V	-2.3 V to -8 V	On	Off
	-2.3 V to -8 V	0 \pm 0.2 V	Off	On

1. External DC blocking capacitors are required on all RF ports. 1000 pF capacitors used for positive control voltage. For higher frequency operation, smaller value DC blocking capacitors can be substituted.
2. If negative control is used, DC blocking capacitors are not required on RF ports.

Functional Schematic

Positive Control Voltage

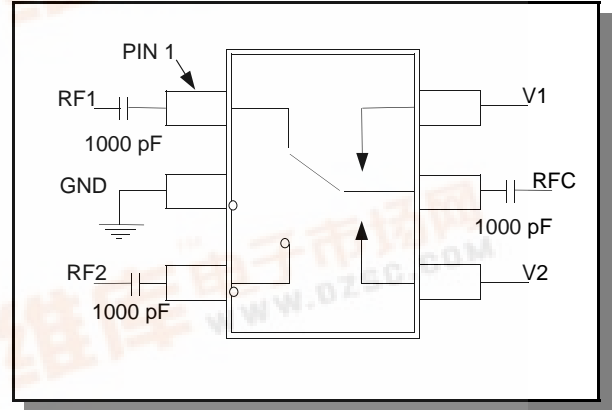

Functional Schematic

Negative Control Voltage

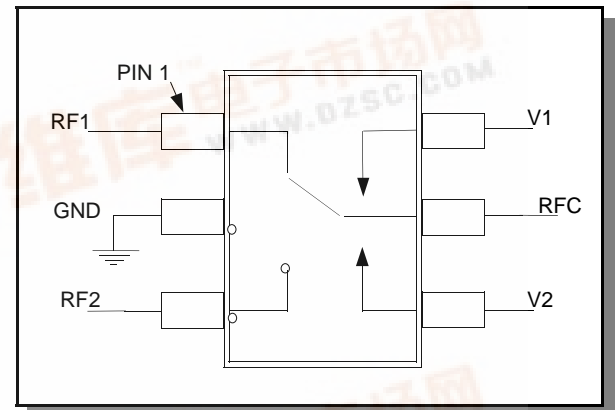

PIN Configuration

PIN	Function	Description
1	RF1	RF In/Out
2	GND	RF Ground
3	RF2	RF In/Out
4	V2	V _{CTRL2}
5	RFC	RF Common
6	V1	V _{CTRL1}

Electrical Specifications: $T_A = 25\text{ }^\circ\text{C}$, $V_{CTL} = 0, -2.3\text{ volts}$ (unless otherwise specified)

Parameter	Test Conditions	Units	Min.	Typ.	Max.
Insertion Loss	DC - 1 GHz	dB		0.35	0.5
	1 - 2 GHz	dB		0.45	0.6
	2 - 3 GHz	dB		0.56	0.8
Isolation	DC - 1 GHz	dB	20	22	
	1 - 2 GHz	dB	15	17	
	2 - 3 GHz	dB	10	12	
V_{SWR}	DC - 3 GHz			1.2:1	1.4:1
P_{1dB} (2.3V supply)	500 MHz - 3 GHz	dBm		21	
P_{1dB} (3V supply)	500 MHz - 3 GHz	dBm		27	
Input IP_2	2-Tone 900 MHz, 5 MHz spacing (3.0 V)	dBm		81	
Input IP_3	2-Tone 900 MHz, 5 MHz spacing (3.0 V)	dBm		52	
TRISE, TFALL	10% to 90% RF, 90% to 10% RF	ns		25	
TON, TOFF	50% Control to 90% RF, Control to 10% RF	ns		25	
Transients	In-Band	mV		25	
Gate Leakage	$V_{CTL} = 2.3\text{ V}$	μA		4	15

Absolute Maximum Ratings¹

Parameter	Absolute Maximum
Max Input Power (0.5 - 3.0 GHz)	
3 V Control	+30 dBm
5 V Control	+33 dBm
Operating Voltage	+8.5 volts
Operating Temperature	-40 °C to +85 °C
Storage Temperature	-65 °C to +150 °C

1. Exceeding any one or combination of these limits may cause permanent damage.

Specifications subject to change without notice.

Typical Performance Curves (Cont'd)

Insertion Loss vs. Frequency Over Temperature

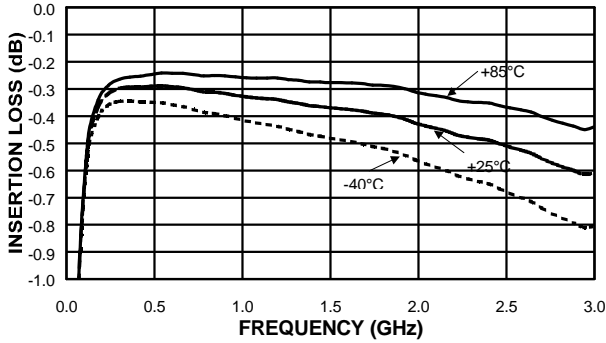

VSWR Over Temperature

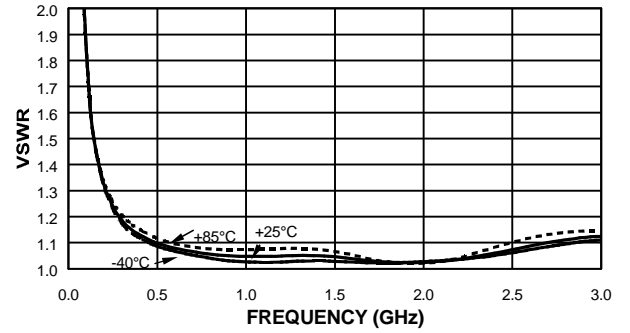

Isolation vs. Frequency Over Temperature

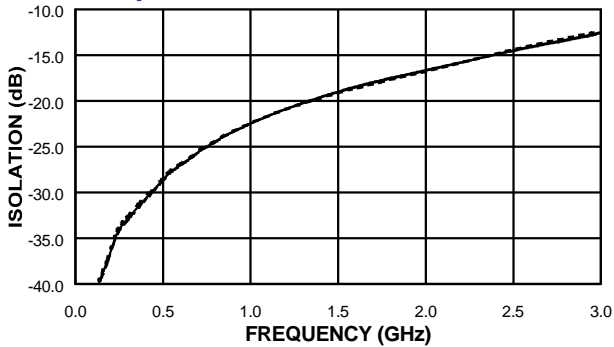

Insertion Loss vs. Frequency (+2.3 V Control, 1000 pF Capacitor on RF Ports)

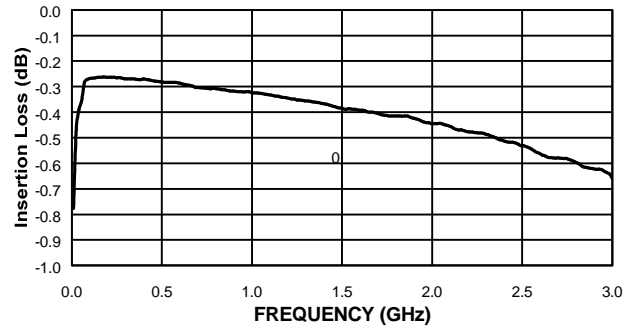

Isolation vs. Frequency (+2.3 V Control, 1000 pF Capacitor on RF Ports)

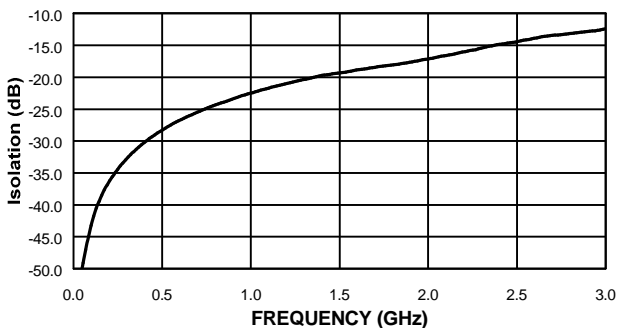

VSWR vs. Frequency (+2.3 V Control, 1000 pF Capacitor on RF Ports)

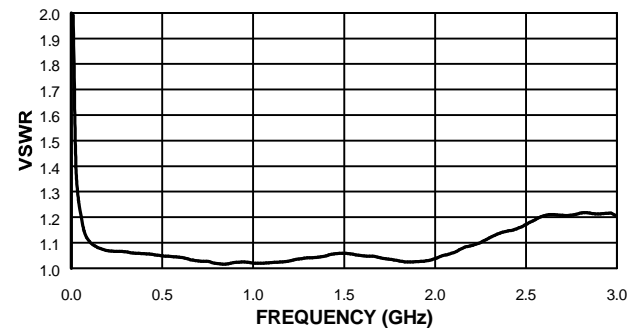

Specifications subject to change without notice.

- North America: Tel. (800) 366-2266, Fax (800) 618-8883
- Asia/Pacific: Tel.+81-44-844-8296, Fax +81-44-844-8298
- Europe: Tel. +44 (1344) 869 595, Fax+44 (1344) 300 020

SC-70 (SOT-363) Plastic Package¹

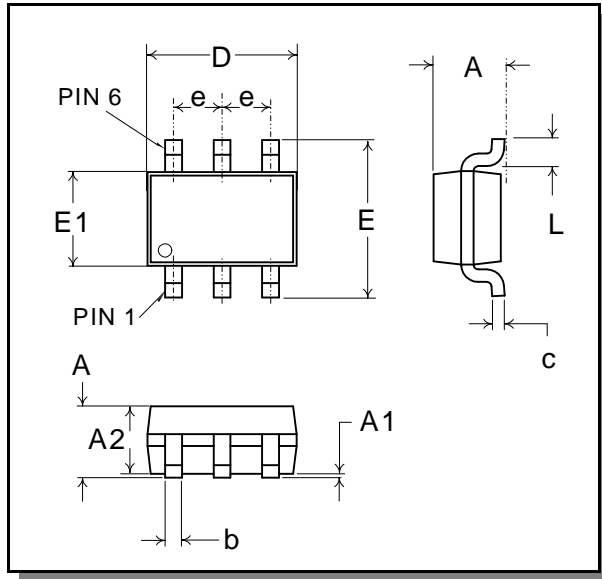

1. All dimensions are JEDEC MO-203-AB Issue A and are shown as in/mm.

SOT-26

Dim	Measurement (mm)		
	Min.	Nom.	Max.
A	-	-	1.10
A1	0	-	0.10
A2	0.70	0.90	1.00
b	0.15	-	0.30
c	0.08	-	0.25
D	-	2.00 basic	-
e	-	0.65 basic	-
E	-	2.10 basic	-
E1	-	1.25 basic	-
L	-	0.42 ref.	-

Ordering Information

Part Number	Package
SW-456 PIN	SC-70 (SOT-363) Plastic Package
SW-456TR	Forward Tape and Reel ¹
SW-456TR 3000	3000 Tape and Reel ¹
SW-456SMB	Sample Board

1. If specific reel size is required, consult factory for part number assignment.

Specifications subject to change without notice.