

Product Description

Stanford Microdevices' SXA-289 amplifier is a high efficiency GaAs Heterojunction Bipolar Transistor (HBT) MMIC housed in low-cost surface-mountable plastic package. These HBT MMICs are fabricated using molecular beam epitaxial growth technology which produces reliable and consistent performance from wafer to wafer and lot to lot.

These amplifiers are specially designed for use as driver devices for infrastructure equipment in the 5-2000 MHz cellular, ISM, WLL and narrowband PCS applications.

Its high linearity makes it an ideal choice for multi-carrier as well as digital applications.

Typical IP3, P1dB, Gain

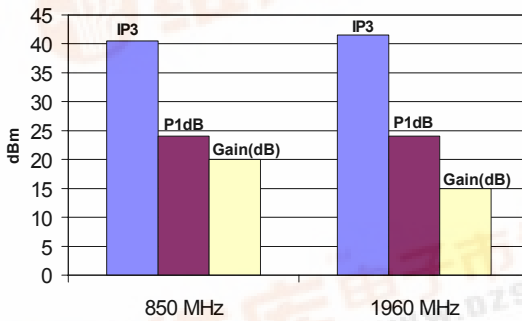

SXA-289

5-2000 MHz Medium Power GaAsHBT Amplifier



Product Features

- Patented High Reliability GaAs HBT Technology
- High Output 3rd Order Intercept : +41.5 dBm typ. at 1960 MHz
- Surface-Mountable Power Plastic Package

Applications

- PCS, Cellular Systems
- High Linearity IF Amplifiers

Symbol	Parameters: Test Conditions: $Z_0 = 50 \text{ Ohms}$, $T_a = 25\text{C}$		Units	Min.	Typ.	Max.
P_{1dB}	Output Power at 1dB Compression	$f = 850 \text{ MHz}$ $f = 1960 \text{ MHz}$	dBm dBm		24.0 24.0	
S_{21}	Small signal gain	$f = 850 \text{ MHz}$ $f = 1960 \text{ MHz}$	dB dB	18.0	20.0 15.0	21.5
S_{11}	Input VSWR	$f = 850 \text{ MHz}$ $f = 1960 \text{ MHz}$	-		1.3:1 1.7:1	
IP_3	Output Third Order Intercept Point ($P_{out}/\text{Tone} = +11 \text{ dBm}$, Tone spacing = 1 MHz)	$f = 850 \text{ MHz}$ $f = 1960 \text{ MHz}$	dBm dBm	38.0	40.5 41.5	
NF	Noise Figure	$f = 850 \text{ MHz}$ $f = 1960 \text{ MHz}$	dB dB		5.0 5.7	
I_d	Device Current	$V_s = 8\text{V}$ $R_{bias} = 27 \text{ ohms}$ $V_{device} = 5 \text{ V typ.}$	mA	85	105	120
$R_{\theta j-l}$	Thermal Resistance (junction - lead)		$^{\circ}\text{C/W}$		108	





SXA-289 5-2000 MHz Power Amplifier

850 MHz Application Circuit Data, $I_{cc}=105\text{mA}$, $T=+25\text{C}$, $R_{bias}=27\ \text{ohm}$, $V_s=8\text{V}$

Note: Tuned for Output IP3

P1dB vs Frequency

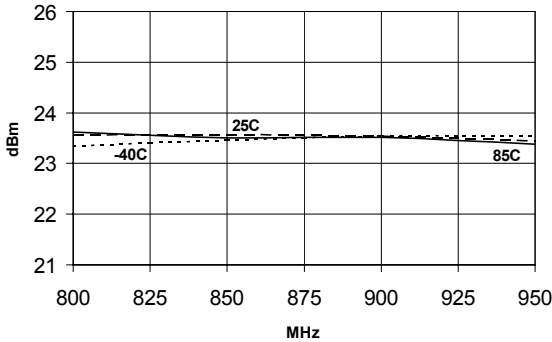

Gain vs. Frequency

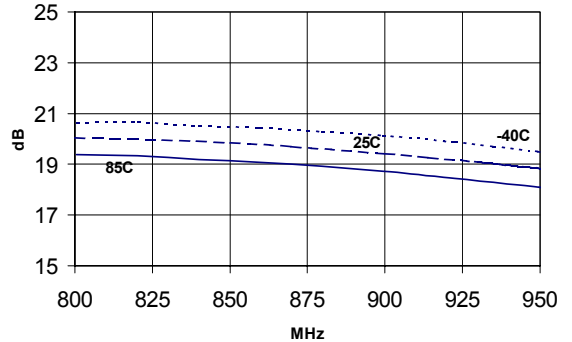

Input/Output Return Loss, Isolation vs Frequency

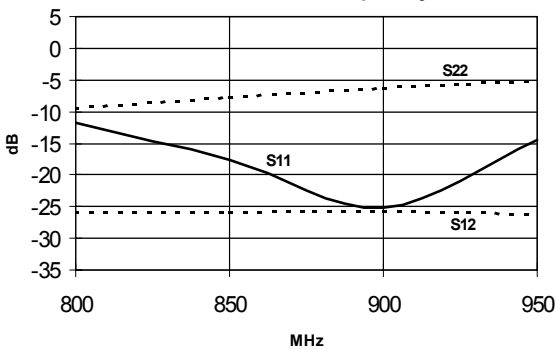

Third Order Intercept vs. Frequency (P_{OUT} per tone = 11dBm)

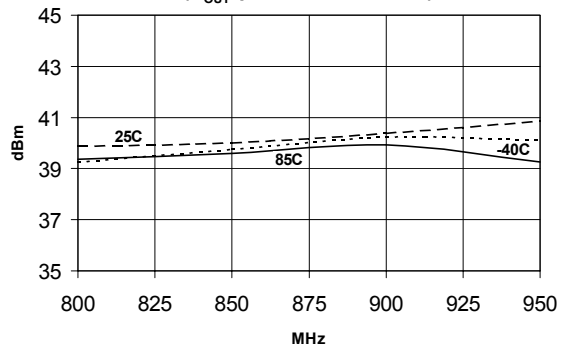

Third Order Intercept vs Tone Power

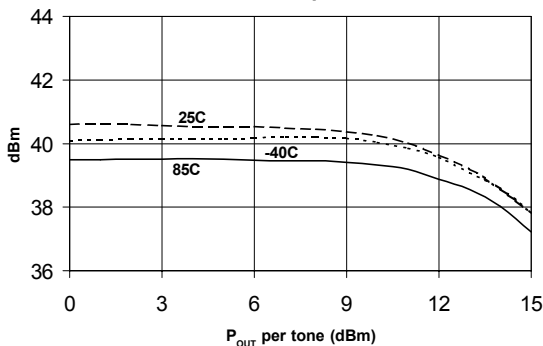

Device Current vs. Source Voltage

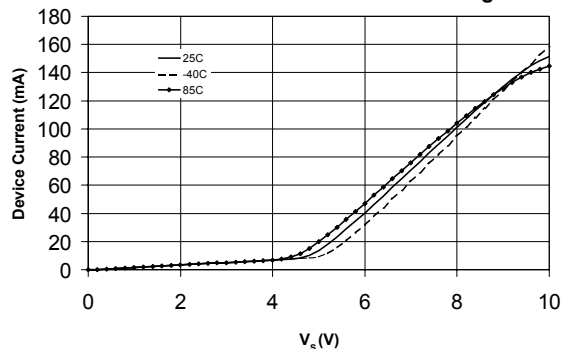



SXA-289 5-2000 MHz Power Amplifier

1960 MHz Application Circuit Data, $I_{cc}=105\text{mA}$, $T=+25\text{C}$, $R_{bias}=27\ \text{ohm}$, $V_s=8\text{V}$

Note: Tuned for Output IP3

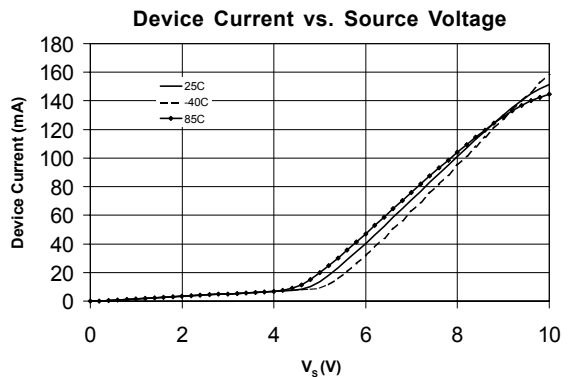
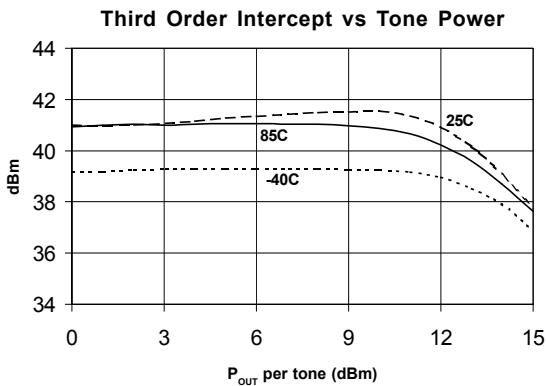
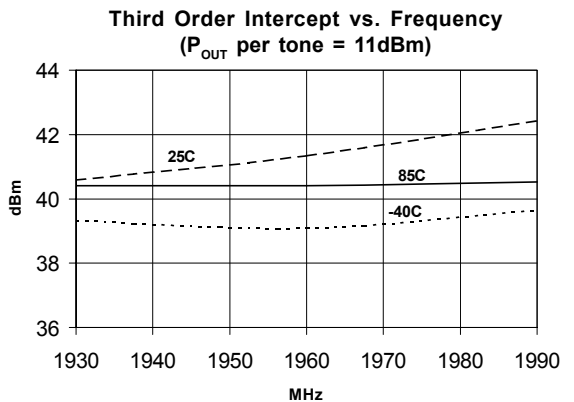
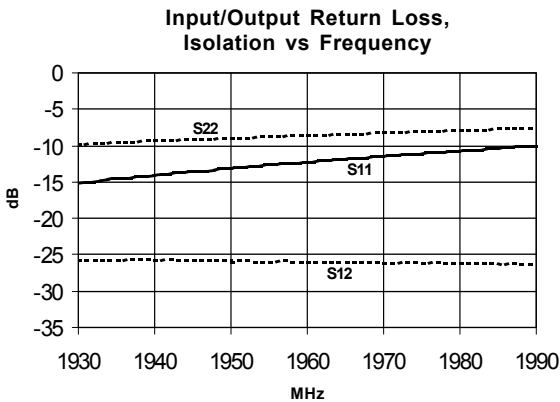
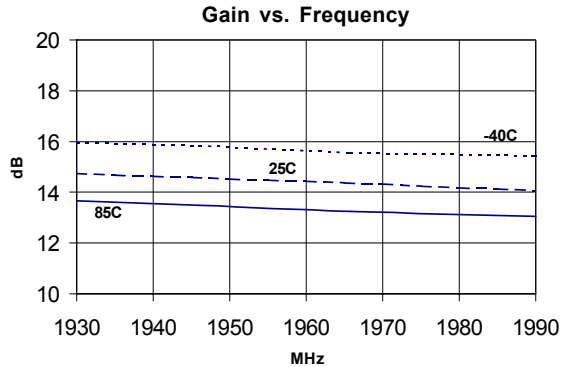
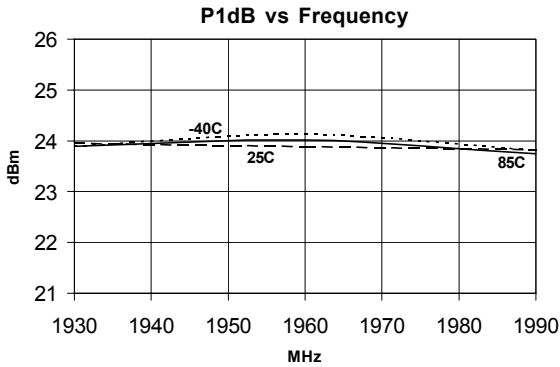

Voltage Feed Resistor Bias Circuit (for $\geq 7V$ supply)

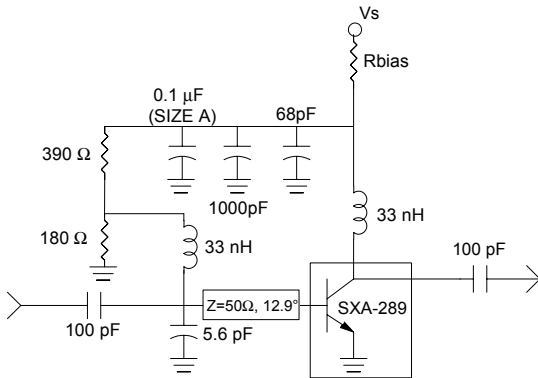

850 MHz Schematic

Recommended Bias Resistor Values				
Supply Voltage(Vs)	7V	8V	10V	12V
Rbias (Ohms)	18	27	47	62
Power Rating	0.5W	1.0W	1.5W	2.0W

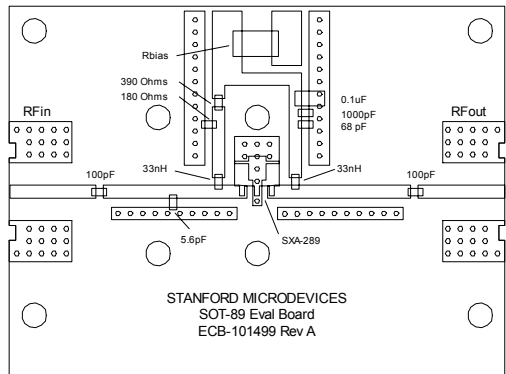

850 MHz Evaluation Board Layout

Active Current Feedback Bias Circuit (for 5V supply)

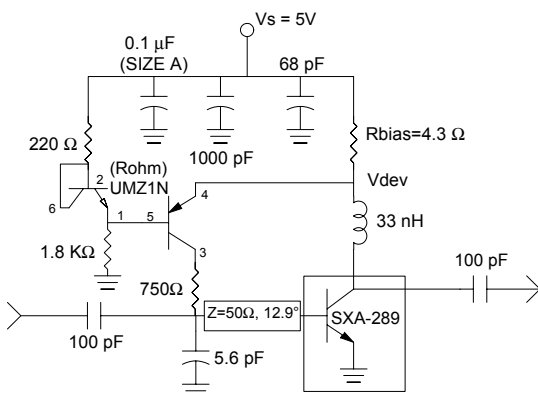

850 MHz Schematic

Frequency	850 MHz
Small Signal Gain (dB)	20.0
Input Return Loss (dB)	-22.8
Output IP3 (dBm)	37.7*
P1dB (dBm)	23.0

*Note: IP3 performance degraded due to lower (4.5V) device voltage.

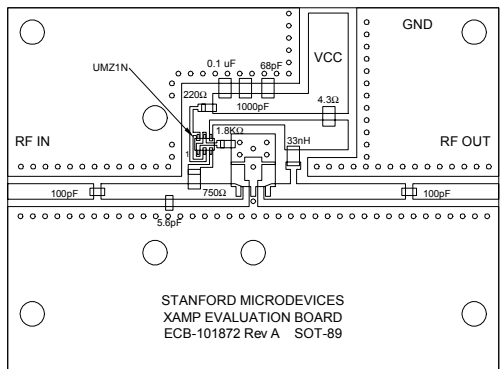

850 MHz Active Bias Evaluation Board Layout

NOTE: Reference Application Note AN-026 for more information on Active Current Feedback Bias Circuit.

Voltage Feed Resistor Bias Circuit (for $\geq 7V$ supply)

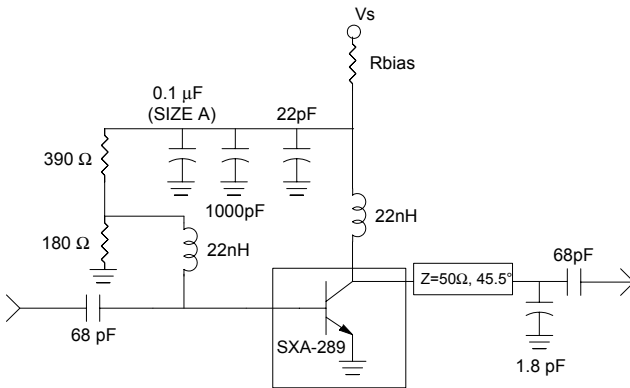

1960 MHz Schematic

Recommended Bias Resistor Values				
Supply Voltage(Vs)	7V	8V	10V	12V
Rbias (Ohms)	18	27	47	62
Power Ratings	0.5W	1.0W	1.5W	2.0W

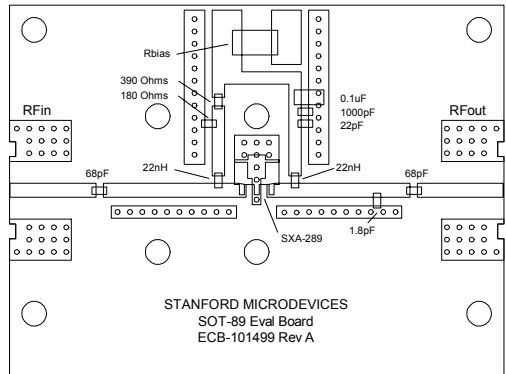

1960 MHz Evaluation Board Layout

Active Current Feedback Bias Circuit (for 5V supply)

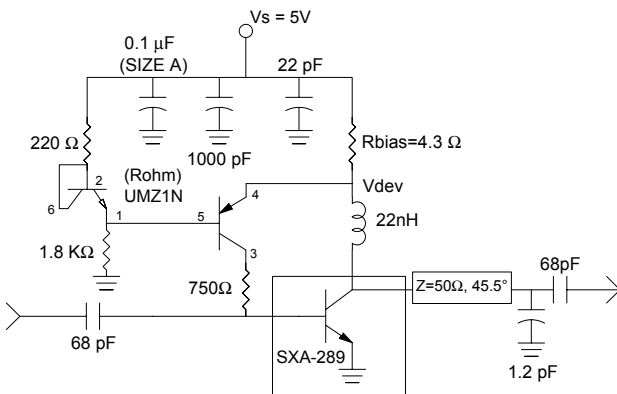

1960 MHz Schematic

Frequency	1960 MHz
Small Signal Gain (dB)	14.9
Input Return Loss (dB)	-12.1
Output IP3 (dBm)	38.0*
P1dB(dBm)	23.3

*Note: IP3 performance degraded due to lower (4.5V) device voltage.

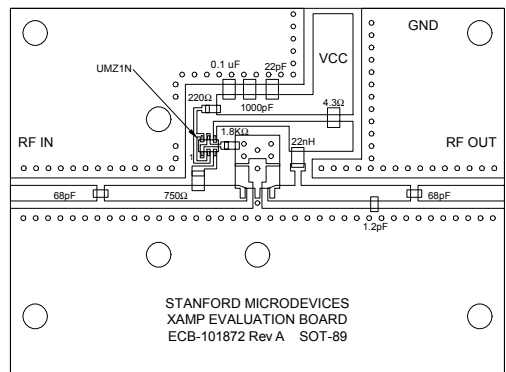

1960 MHz Active Bias Evaluation Board Layout

NOTE: Reference Application Note AN-026 for more information on Active Current Feedback Bias Circuit.



Absolute Maximum Ratings

Parameter	Absolute Maximum
Device Voltage	6V
Device Current	200mA
Power Dissipation	1500mW
RF Input Power	100mW
Junction Temperature	+150C
Operating Temperature	-40C to +85C
Storage Temperature	-65C to +150C

SXA-289 5-2000 MHz Power Amplifier

Part Number Ordering Information

Part Number	Devices Per Reel	Reel Size
SXA-289	1000	7"

Part Symbolization

The part will be symbolized with a "XA2" designator on the top surface of the package.

Pin Description

Pin #	Function	Description
1	Base	Base Pin
2	GND & Emitter	Connection to ground. Use via holes to reduce lead inductance. Place vias as close to ground leads as possible.
3	Collector	Collector Pin
4	GND & Emitter	Same as Pin 2



Caution: ESD sensitive

Appropriate precautions in handling, packaging and testing devices must be observed.

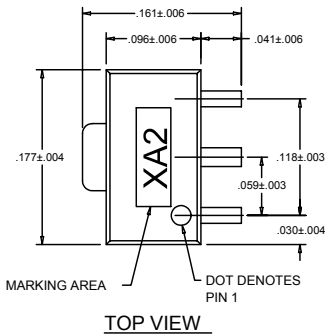

Package Dimensions

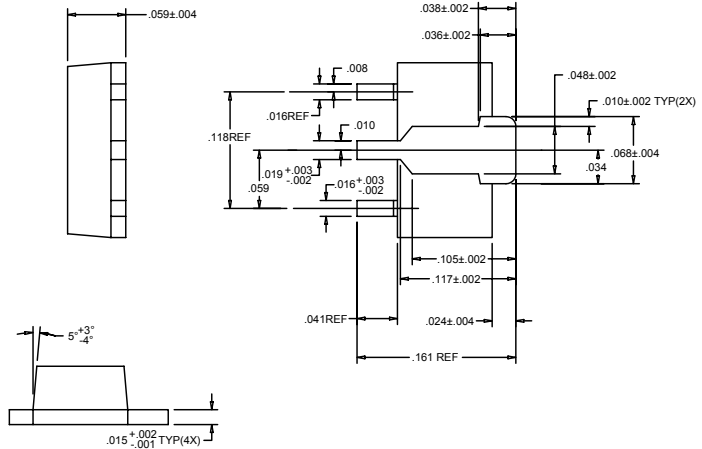

PCB Pad Layout

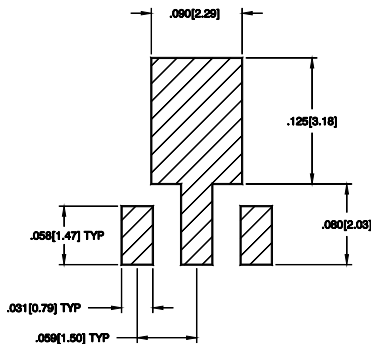

Recommended via and mounting hole pattern (For RF Ground and Thermal considerations)

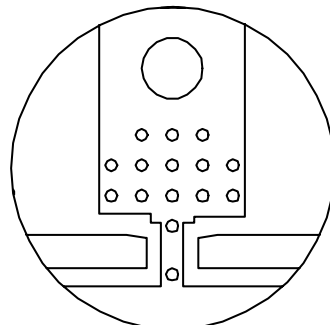

DIMENSIONS ARE IN INCHES [MM]

Use multiple plated-through vias holes located close to the package pins to ensure a good RF ground connection to a continuous groundplane on the backside of the board.