



Product Description

Stanford Microdevices' SXH-189 amplifier is a high efficiency GaAs Heterojunction Bipolar Transistor (HBT) MMICs housed in low-cost surface-mountable plastic package. These HBT MMICs are fabricated using molecular beam epitaxial growth technology which produces reliable and consistent performance from wafer to wafer and lot to lot.

These amplifiers are specially designed for use as driver devices for infrastructure equipment in the 5-2000 MHz cellular, ISM, WLL and narrowband PCS applications.

Its high linearity makes it an ideal choice for multi-carrier as well as digital applications.

Typical IP3, P1dB, Gain

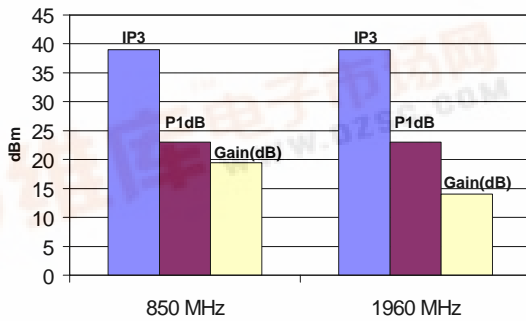

SXH-189 5-2000 MHz Medium Power GaAsHBT Amplifier



Product Features

- Patented High Reliability GaAs HBT Technology
- High 3rd Order Intercept : +39 dBm typ. at 1960 MHz
- Surface-Mountable Power Plastic Package

Applications

- PCS, Cellular Systems
- High Linearity IF Amplifiers

Symbol	Parameters: Test Conditions: $Z_0 = 50 \text{ Ohms}$, $T_a = 25\text{C}$		Units	Min.	Typ.	Max.
P_{1dB}	Output Power at 1dB Compression	$f = 850 \text{ MHz}$ $f = 1960 \text{ MHz}$	dBm dBm		23.0 23.0	
S_{21}	Small signal gain	$f = 850 \text{ MHz}$ $f = 1960 \text{ MHz}$	dB dB	17.5	19.5 14.0	
S_{11}	Input VSWR	$f = 850 \text{ MHz}$ $f = 1960 \text{ MHz}$	-		1.5:1 1.9:1	
IP_3	Third Order Intercept Point	$f = 850 \text{ MHz}$ $f = 1960 \text{ MHz}$	dBm dBm		39.0 39.0	
NF	Noise Figure	$f = 850 \text{ MHz}$ $f = 1960 \text{ MHz}$	dB dB		5.0 5.0	
I_d	Device Current	$V_s = 8\text{V}$ $R_{bias} = 27 \text{ ohms}$ $V_{device} \approx 5\text{V}$	mA	80	100	130
$R_{\theta j-l}$	Thermal Resistance (junction - lead)		$^{\circ}\text{C/W}$		108	

The information provided herein is believed to be reliable at press time. Stanford Microdevices assumes no responsibility for inaccuracies or omissions. Stanford Microdevices assumes no responsibility for the use of this information, and all such information shall be entirely at the user's own risk. Prices and specifications are subject to change without notice. No patent rights or licenses to any of the circuits described herein are implied or granted to any third party. Stanford Microdevices does not authorize or warrant any Stanford Microdevices product for use in life-support devices and/or systems. Copyright 2000 Stanford Microdevices, Inc. All worldwide rights reserved.

522 Almanor Ave., Sunnyvale, CA 94085

Phone: (800) SMI-MMIC

<http://www.stanfordmicro.com>





SXH-189 5-2000 MHz Power Amplifier

850 MHz Application Circuit Data, $I_{cc}=110\text{mA}$, $T=+25\text{C}$, $R_{bias}=27\ \Omega$, $V_s=8\text{V}$

Note: Tuned for Output IP3

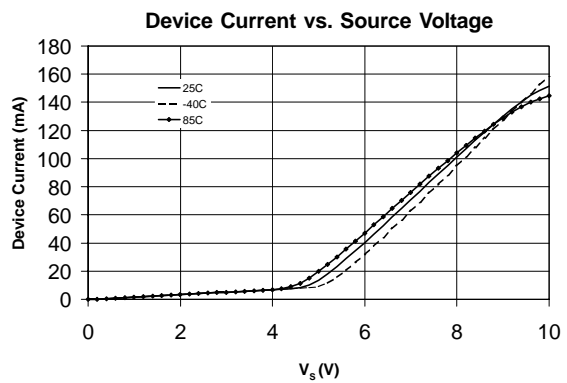
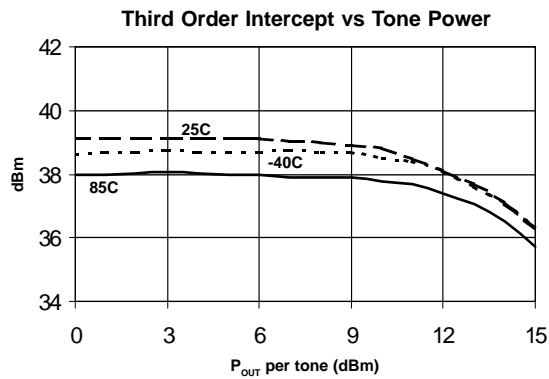
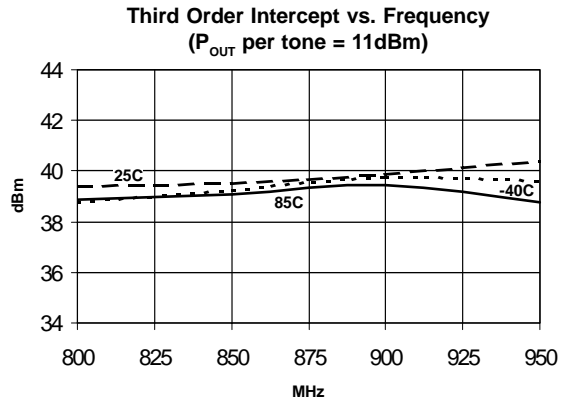
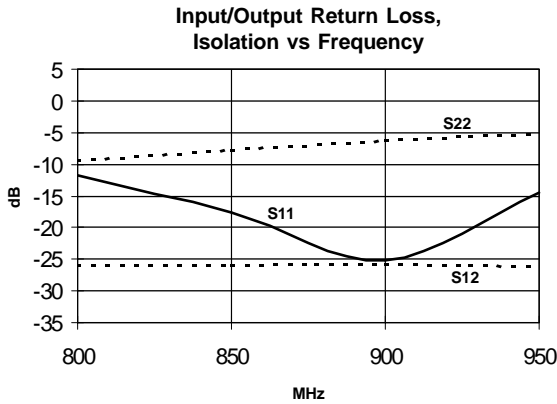
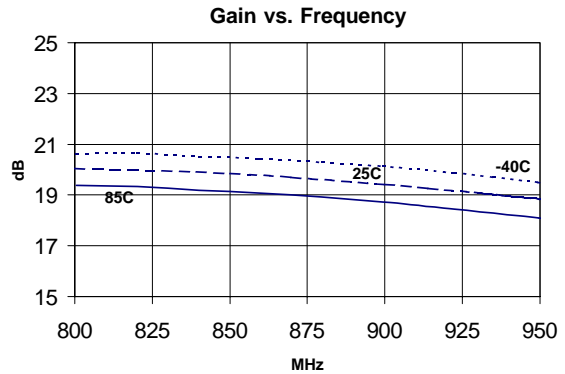
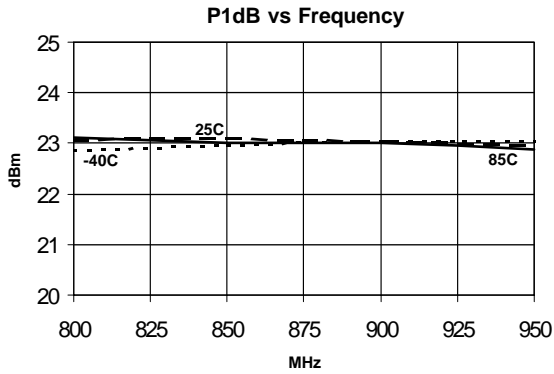



SXH-189 5-2000 MHz Power Amplifier

1960 MHz Application Circuit Data, $I_{cc}=110\text{mA}$, $T=+25\text{C}$, $R_{bias}=27\ \text{ohm}$, $V_s=8\text{V}$

Note: Tuned for Output IP3

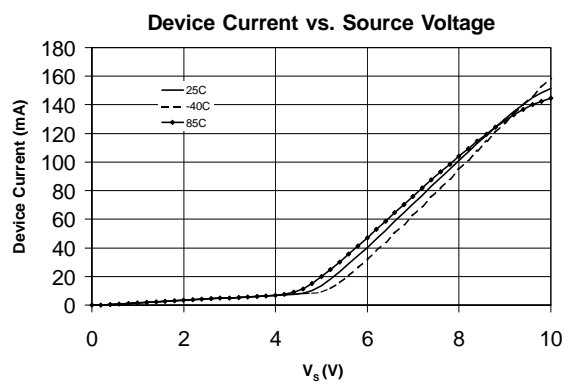
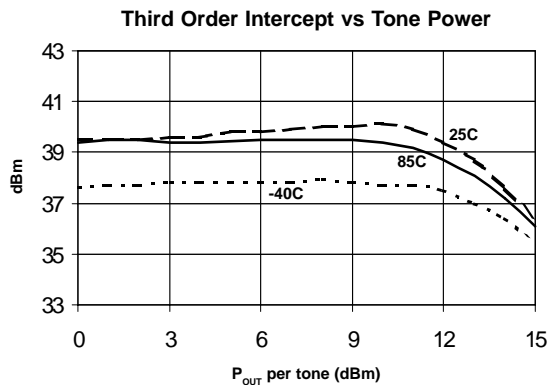
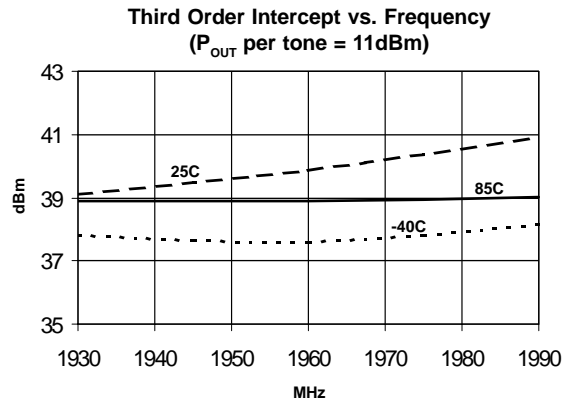
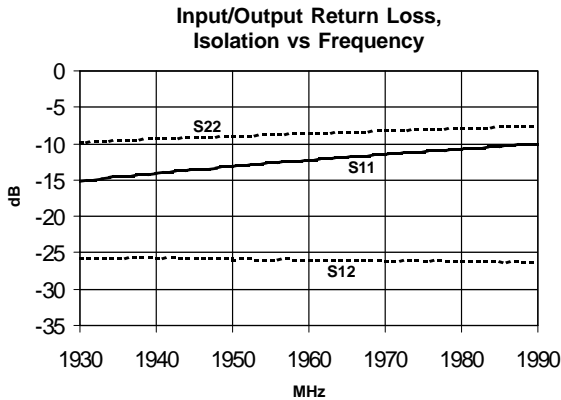
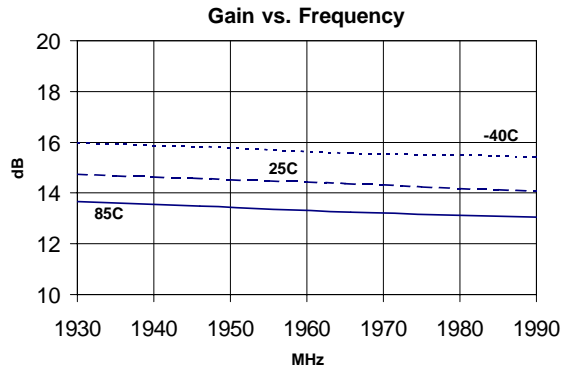
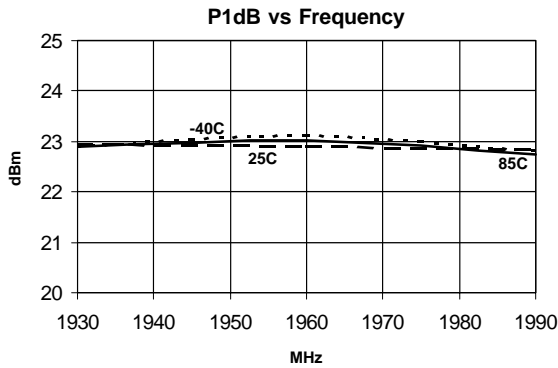



850 MHz Application Circuit

SXH-189 5-2000 MHz Power Amplifier

Voltage Feed Resistor Bias Circuit (for > 7V supply)

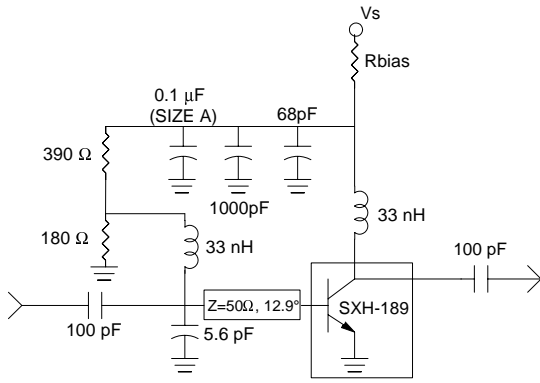

850 MHz Schematic

Recommended Bias Resistor Values				
Supply Voltage(Vs)	7V	8V	10V	12V
Rbias (Ohms)	18	27	47	62
Power Rating	0.5W	1.0W	1.5W	2.0W

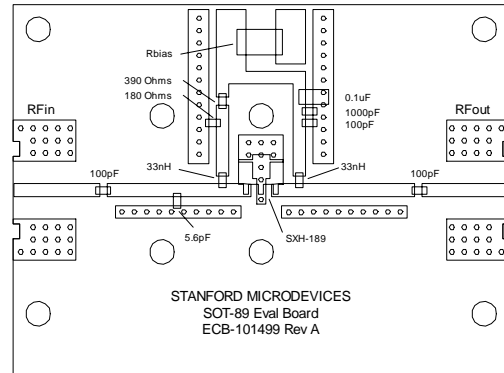

850 MHz Evaluation Board Layout

Active Current Feedback Bias Circuit (for 5V supply)

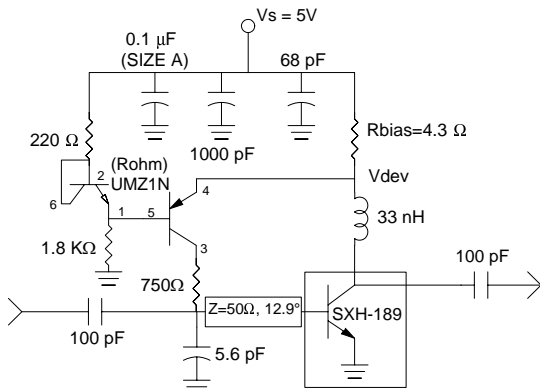

850 MHz Schematic

Frequency	850 MHz
Small Signal Gain (dB)	20.0
Input Return Loss (dB)	-22.8
Output IP3 (dBm)	37.7*
P1dB (dBm)	23.0

*Note: IP3 performance degraded due to lower (4.5V) device voltage.

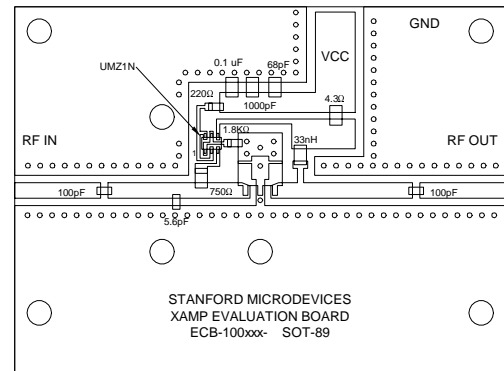

850 MHz Active Bias Evaluation Board Layout

NOTE: Reference Application Note AN-023 for more information on Active Current Feedback Bias Circuit.

ALL COMPONENTS 0603 UNLESS NOTED OTHERWISE

Voltage Feed Resistor Bias Circuit (for > 7V supply)

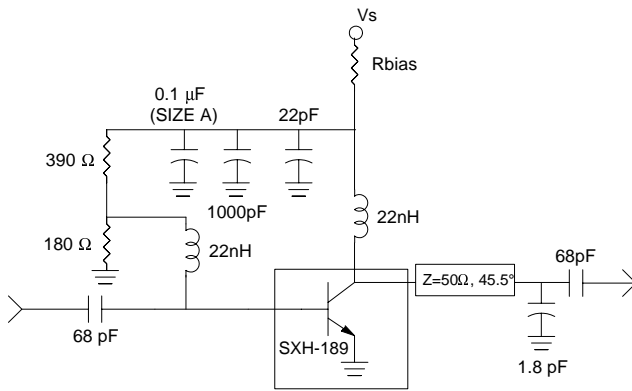

1960 MHz Schematic

Recommended Bias Resistor Values				
Supply Voltage(Vs)	7V	8V	10V	12V
Rbias (Ohms)	18	27	47	62
Power Rating	0.5W	1.0W	1.5W	2.0W

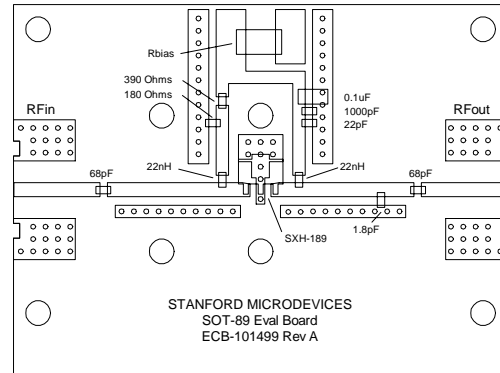

1960 MHz Evaluation Board Layout

Active Current Feedback Bias Circuit (for 5V supply)

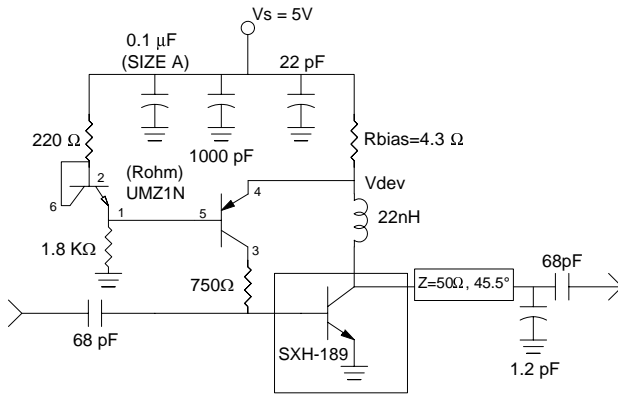

1960 MHz Schematic

Frequency	1960 MHz
Small Signal Gain (dB)	14.9
Input Return Loss (dB)	-12.1
Output IP3 (dBm)	38.0*
P1dB(dBm)	23.3

*Note: IP3 performance degraded due to lower (4.5V) device voltage.

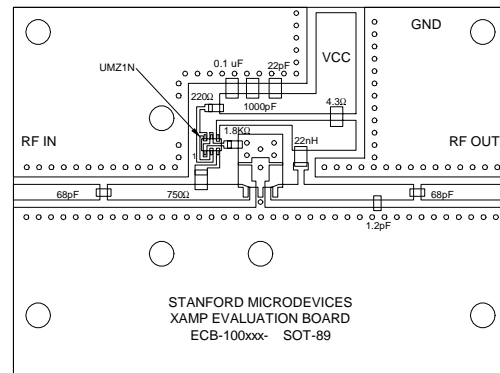

1960 MHz Active Bias Evaluation Board Layout

NOTE: Reference Application Note AN-023 for more information on Active Current Feedback Bias Circuit.

ALL COMPONENTS 0603 UNLESS NOTED OTHERWISE



Absolute Maximum Ratings

Parameter	Absolute Maximum
Device Voltage	6V
Device Current	200mA
Power Dissipation	1500mW
RF Input Power	100mW
Junction Temperature	+150C
Operating Temperature	-40C to +85C
Storage Temperature	-65C to +150C



Caution: ESD sensitive
Appropriate precautions in handling, packaging and testing devices must be observed.

Pin Description

Pin #	Function	Description
1	Base	Base pin.
2	GND & Emitter	Connection to ground. Use via holes to reduce lead inductance. Place vias as close to ground leads as possible.
3	Collector	Collector pin.
4	GND & Emitter	Same as Pin 2

SXH-189 5-2000 MHz Power Amplifier

Part Number Ordering Information

Part Number	Devices Per Reel	Reel Size
SXH-189	1000	7"

Part Symbolization

The part will be symbolized with a "XA2" designator on the top surface of the package.

Package Dimensions

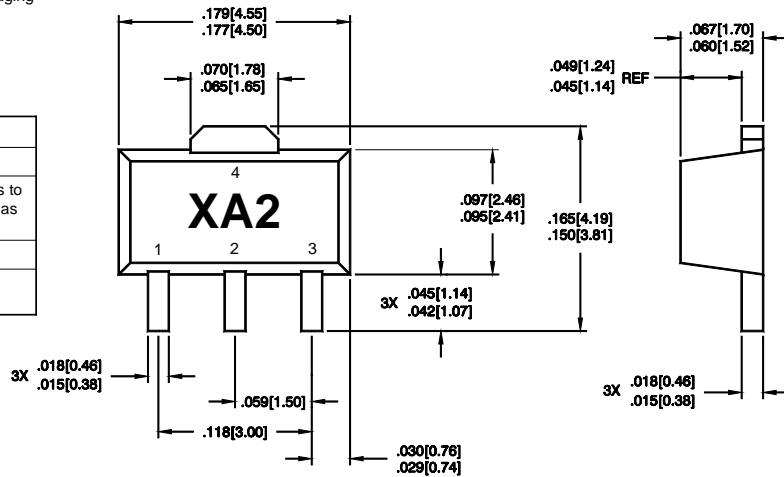

Pin assignments shown for reference only, not marked on part

PCB Pad Layout

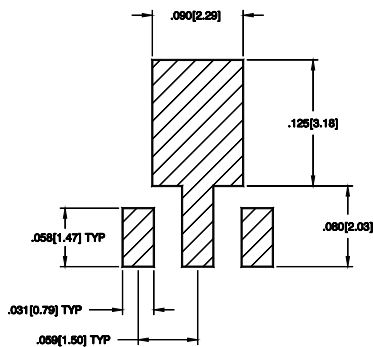

Recommended via and mounting hole pattern
(For RF Ground and Thermal considerations)

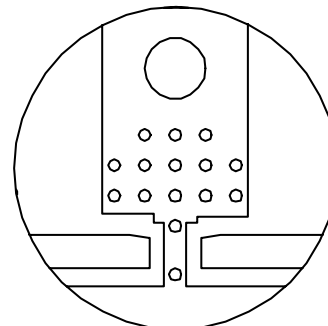

DIMENSIONS ARE IN INCHES [MM]

Use multiple plated-through vias holes located close to the package pins to ensure a good RF ground connection to a continuous groundplane on the backside of the board.