

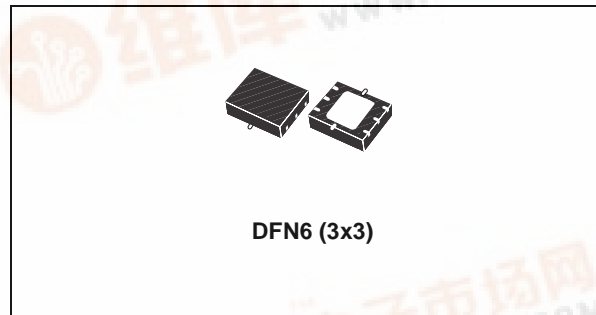

ST1S03

1.5A, 1.5 MHz ADJUSTABLE, STEP-DOWN SWITCHING REGULATOR IN DFN6

- STEP-DOWN CURRENT MODE PWM (1.5MHz) DC-DC CONVERTER
- 2% DC OUTPUT VOLTAGE TOLERANCE
- INTERNAL SOFT START FOR START-UP
- CURRENT LIMITATION AND POWER ON DELAY OF 50-100µs
- TYPICAL EFFICIENCY: > 70% OVER ALL OPERATING CONDITIONS
- 1.5A OUTPUT CURRENT CAPABILITY
- NOT SWITCHING QUIESCENT CURRENT: MAX 2.5mA OVER TEMPERATURE RANGE
- SWITCH V_{DS} : MAX 350mV @ ISW=750mA
- USES TINY CAPACITORS AND INDUCTORS
- AVAILABLE IN DFN 3x3 EXPOSED PAD



DESCRIPTION

The ST1S03 is a step down DC-DC converter optimized for powering low-voltage digital core in HDD applications and, generally, to replace the high current linear solution when the power dissipation may cause a high heating of the application environment. It provides up to 1.5A over an input voltage range of 3V to 16V. An high

switching frequency (1.5MHz) allows the use of tiny surface-mount components: as well as the resistor divider to set the output voltage value, only an inductor, a schottky diode and two capacitors are required. Besides, a low output ripple is guaranteed by the current mode PWM topology and by the use of low E.S.R. SMD ceramic capacitors. The device is thermal protected and current limited to prevent damages due to accidental short circuit. The ST1S03 is available in DFN6 package.

Figure 1: Schematic Diagram

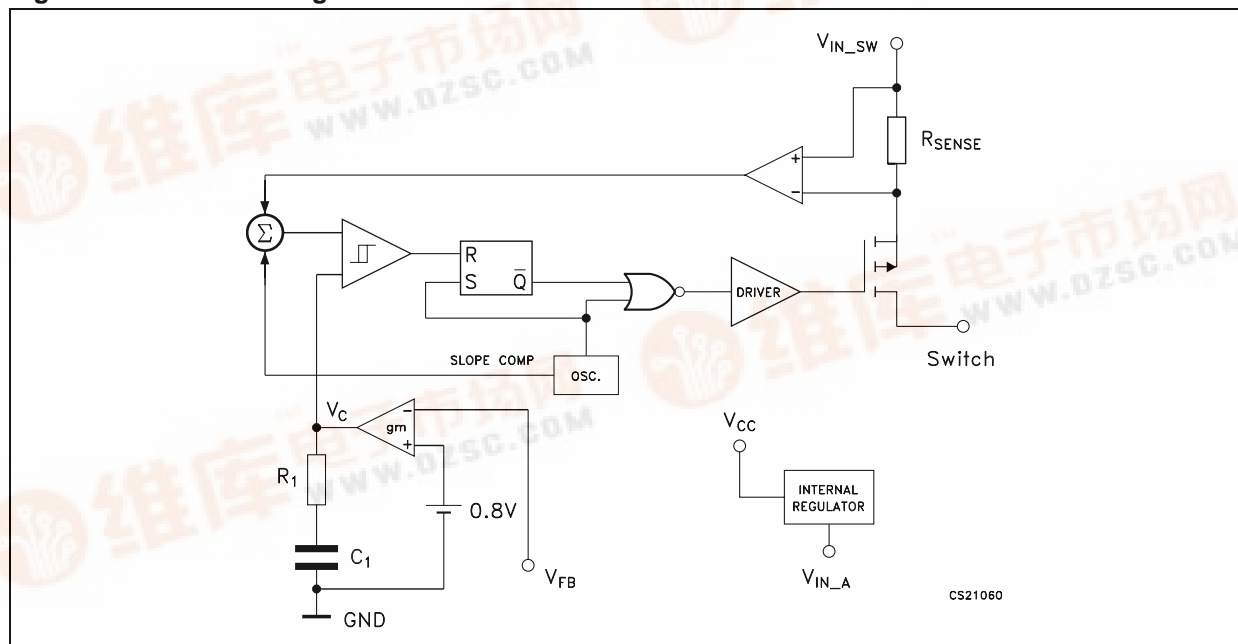

ST1S03

Table 1: Order Codes

SYMBOL	DFN6	(Tape & Reel)
ST1S03	ST1S03PM	ST1S03RPM

Figure 2: Pin Connection (top through view)

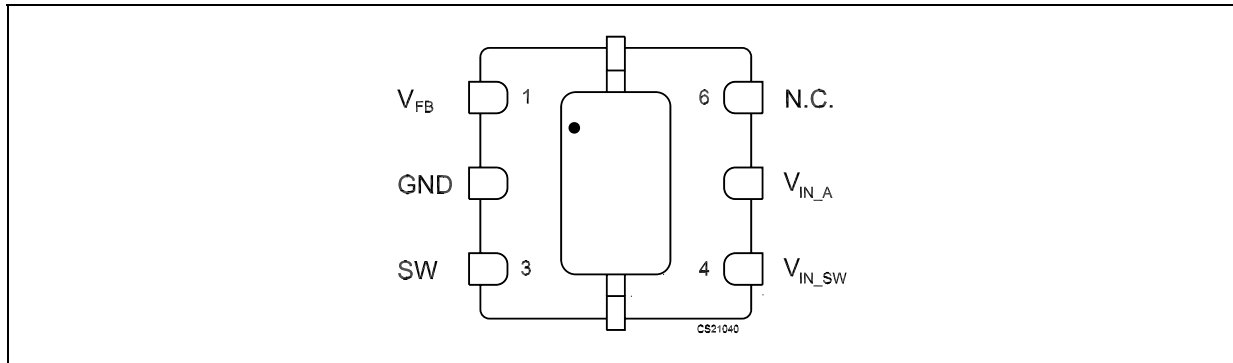

Table 2: Pin Description

PIN N°	Symbol	Name and Function
1	V_{FB}	Voltage of Feedback
2	GND	System Ground
3	SW	Output of the internal Power Switch
4	V_{IN_SW}	Power Supply for the MOSFET Switch
5	V_{IN_A}	Power Supply for the Analog Circuit
6	N.C.	Not Connected

Table 3: Absolute Maximum Ratings

Symbol	Parameter	Value	Unit
V_{I_SW}	Positive Power Supply Voltage	-0.3 to 16	V
V_{I_SW}	Positive Power Supply Voltage	-0.3 to 16	V
SWITCH Voltage	Max Voltage of output pin	-0.3 to 16	V
V_{FB}	Feedback Voltage	2.5	V
I_{VFB}	Common mode input voltage	± 1	mA
T_J	Max Junction Temperature	150	$^{\circ}\text{C}$
T_{STG}	Storage Temperature Range	-25 to 150	$^{\circ}\text{C}$
T_{LEAD}	Lead Temperature (Soldering) 10 Sec.	300	$^{\circ}\text{C}$

Absolute Maximum Ratings are those beyond which damage to the device may occur. Functional operation under these condition is not implied.

Table 4: Thermal Data

Symbol	Parameter	DFN6	Unit
R_{THJ-C}	Thermal Resistance Junction-case	10	$^{\circ}\text{C}/\text{W}$
R_{THJ-A}	Thermal Resistance Junction-ambient	55	$^{\circ}\text{C}/\text{W}$

Table 5: Electrical Characteristics ($V_{IN_SW} = V_{IN_A} = 5V$, $C_I = 4.7\mu F$, $C_O = 22\mu F$, $L1 = 3.3\mu H$, $T_J = 0$ to $125^\circ C$, unless otherwise specified. Typical values are referred to $25^\circ C$)

Symbol	Parameter	Test Conditions	Min.	Typ.	Max.	Unit
FB	Feedback Voltage		784	800	816	mV
PSRR	Feedback PSRR	1Hz < Frequency V_{IN}		-60		dB
I_{FB}	V_{FB} Pin Bias Current				600	nA
BW	Bandwidth of Error Amplifier	Closed Loop		300		KHz
I_Q	Quiescent Current	No Switching			2.5	mA
I_{OUT}	Output Current	$V_{IN} = 3V$ to $16V$	1.5			A
I_{MIN}	Minimum Output Current		1			mA
$\%V_{OUT}/\Delta V_{IN}$	Reference Line Regulation	$V_{IN} = 3V$ to $16V$		0.032	0.06	$\%V_{OUT}/\Delta V_{IN}$
$\%V_{OUT}/\Delta I_{OUT}$	Reference Load Regulation	$I_{OUT} = 10mA$ to $1.2A$		0.0014	0.003	$\%V_{OUT}/mA$
PWM f_S	PWM Switching Frequency (1)	$V_{FB} = 0.8V$, $T_A = 25^\circ C$	1.2	1.5	1.8	MHz
D_{MAX}	Maximum Duty Cycle			87		%
I_{SWL}	Switching Current Limitation		1.65			A
V_{DS}	Switch V_{DS}	$I_{SW} = 750 mA$		200	350	mV
E	Efficiency	$I_{OUT} = 10mA$ to $1.2A$	70			%
T_{SHDN}	Thermal Shut Down (1)		130	150		$^\circ C$
T_{HYS}	Thermal Shut Down Hysteresis (1)			15		$^\circ C$
$\Delta V_{OUT}/\Delta I_{OUT}$	Load Transient Response (1)	$I_{OUT} = 100mA$ to $700mA$ $t_R = t_F \geq 100ns$, $T_A = 25^\circ C$	-5		+5	$\%V_O$
$\Delta V_{OUT}/\Delta I_{OUT}$ @ $I_O = short$	Short Circuit Removal Response (1)	$I_{OUT} = 10mA$ to short, $T_A = 25^\circ C$			+5	$\%V_O$

NOTE 1: Guaranteed by design, not tested in production.

ST1S03

APPLICATION NOTES

The ST1S03 is an adjustable current mode PWM step-down DC/DC converter with internal 1.5A power switch, packaged in a 6-lead DFN 3x3.

It's a complete 1.5A switching regulator with its internal compensation eliminating additional component.

The constant frequency, current mode, PWM architecture and stable operation with ceramic capacitors results in low, predictable output ripple. However, in order to keep the output regulated, the device goes in pulse skipping mode when a very light load is required.

To clamp the error amplifier reference voltage a Soft Start control block generating a voltage ramp, has been implemented. Besides an On-Chip Power on Reset of $50 = 100\mu\text{s}$ ensure the proper operation when switching on the power supply. Other circuits fitted to the device protection are the Thermal Shut down block which turn off the regulator when the junction temperature exceeds 150°C typically and the Cycle-by-cycle Current Limiting that provides protection against shorted outputs.

Being the ST1S03 an adjustable regulator, the output voltage is determined by an external

resistor divider. The desired value is given by the following equation:

$$V_{\text{OUT}} = V_{\text{FB}} [1 + R_1/R_2]$$

To make the device working, only other four external components are required: a Schottky diode, an inductor and two capacitors. The chosen inductor must be able to not saturate at the peak current level. Besides, its value can be selected keeping in account that a large inductor value increases the efficiency at low output current and reduces output voltage ripple, while a smaller inductor can be chosen when it is important to reduce the package size and the total cost of the application. Finally, the ST1S03 has been designed to work properly with X5R or X7R SMD ceramic capacitors both at the input and at the output. This kind of capacitors, thanks to their very low series resistance (ESR), minimize the output voltage ripple. Other low ESR capacitors can be used according to the need of the application without invalidating the right functioning of the device. Due to the high switching frequency and peak current, it is important to optimize the application environment reducing the length of the PCB traces and placing all the external component near the device.

Figure 3: Application Circuit

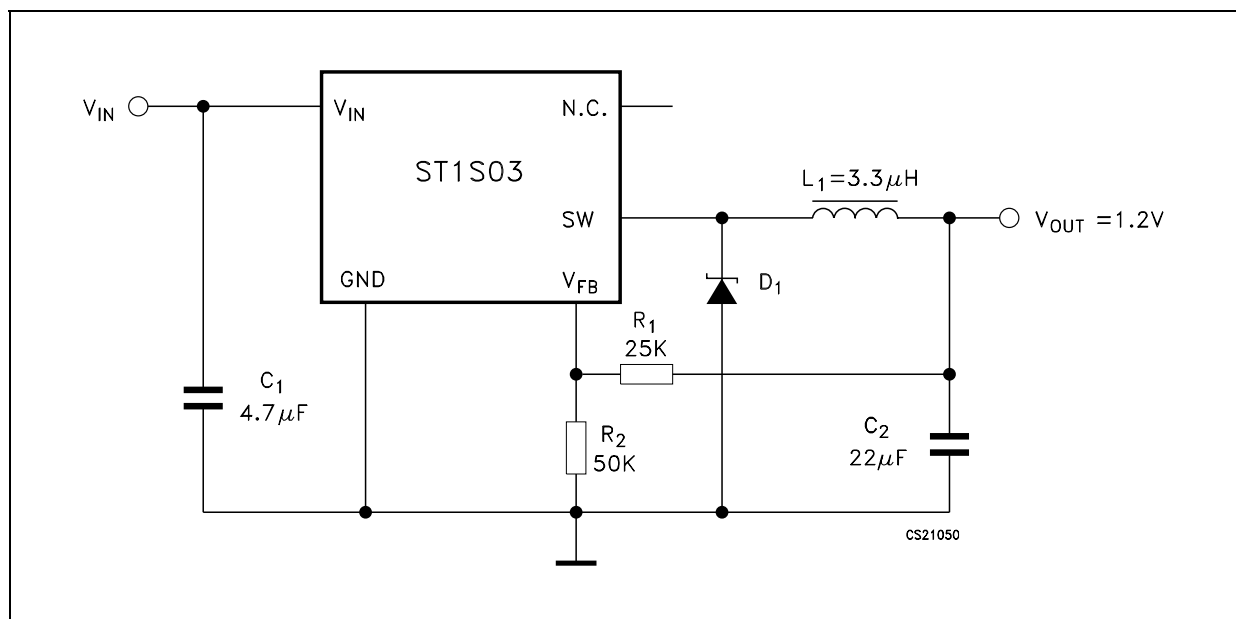

TYPICAL CHARACTERISTICS ($C_{IN} = 4.7\mu F$, $C_O = 22\mu F$, $L1 = 3.3\mu H$, unless otherwise specified)

Figure 4: Load Voltage Feedback vs Temperature

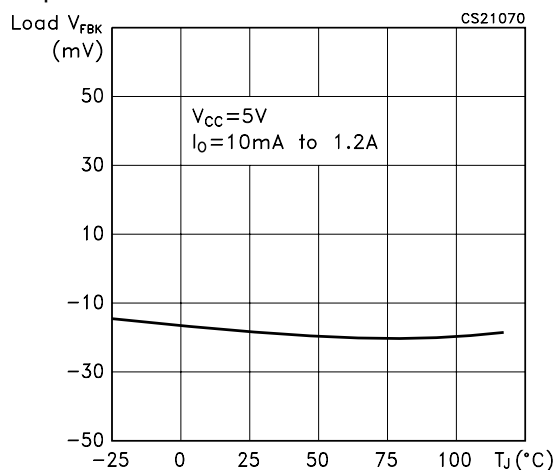

Figure 5: Voltage Feedback vs Temperature

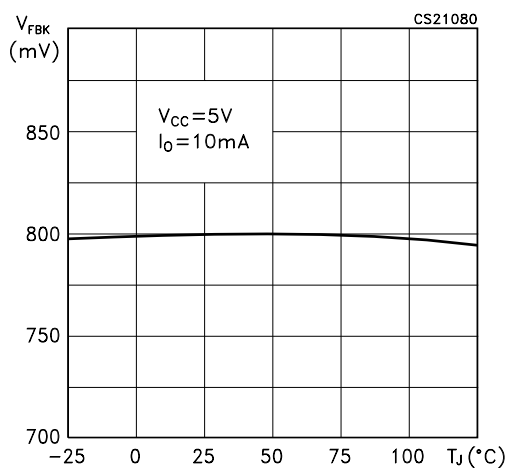

Figure 6: Line Output Voltage Regulation vs Temperature

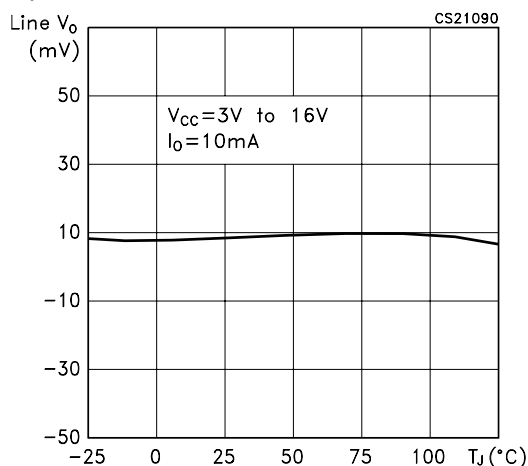

Figure 7: Line Voltage Feedback vs Temperature

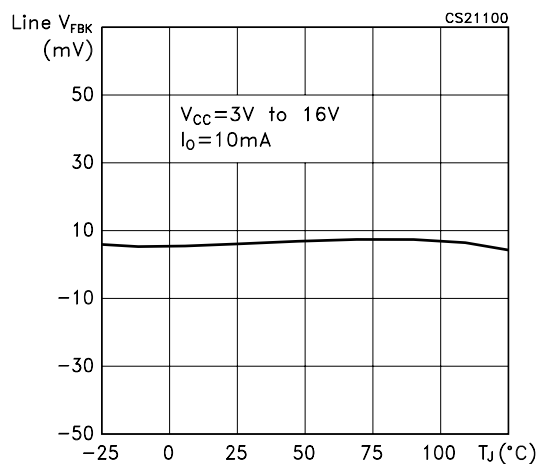

Figure 8: Voltage Feedback vs Output Current

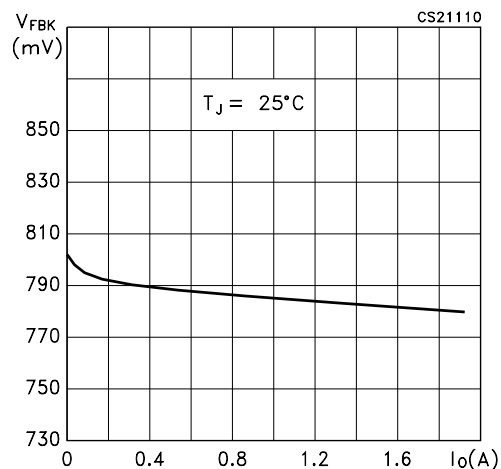

Figure 9: PWM Switching Frequency vs Temperature

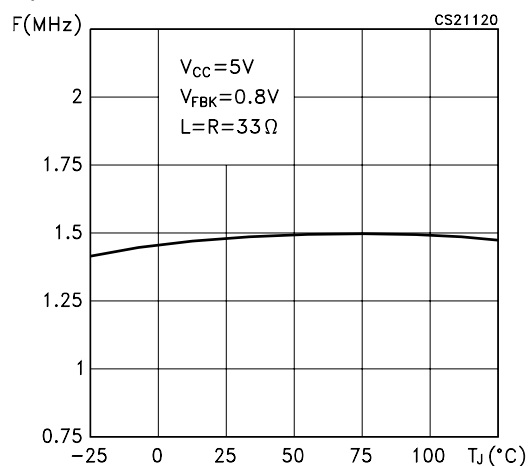

Figure 10: Quiescent Current vs Temperature

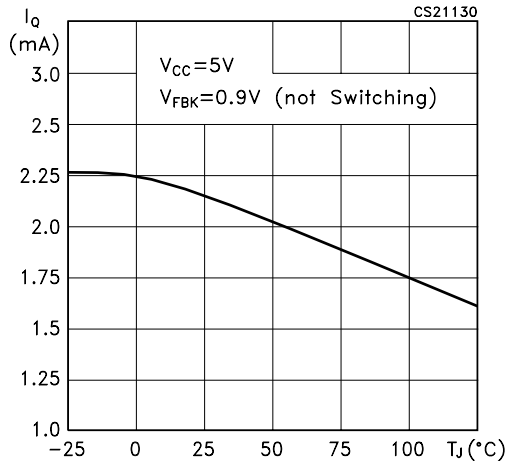

Figure 13: Efficiency vs Temperature

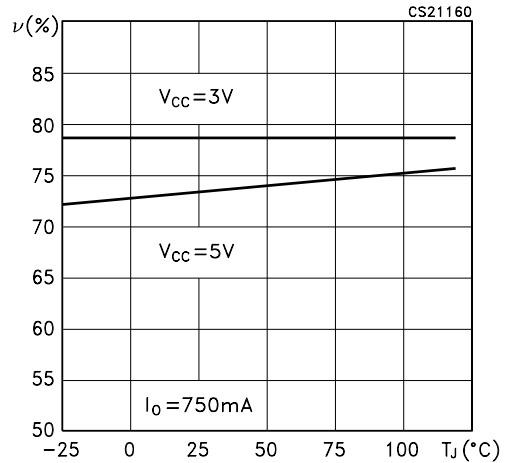

Figure 11: Quiescent Current vs Input Voltage

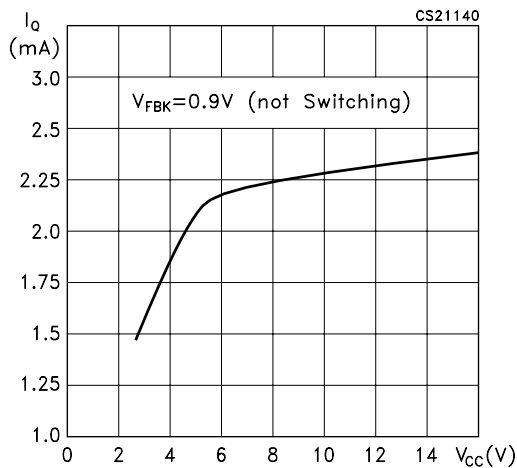

Figure 14: Efficiency vs Output Current

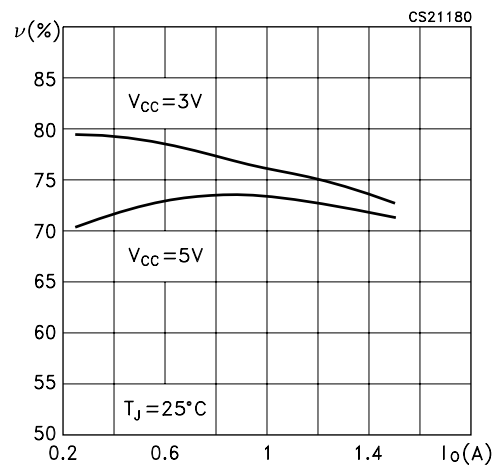

Figure 12: Minimum Operating Voltage vs Output Voltage

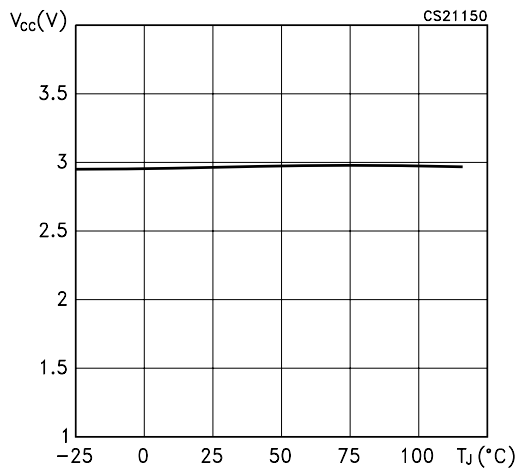

Figure 15: Switch VDS vs Temperature

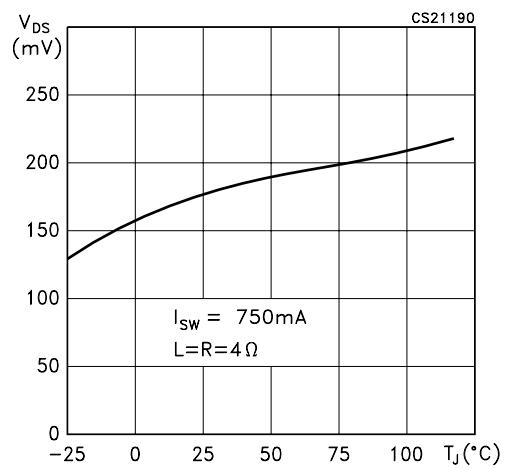

Figure 16: Switch RDS-ON vs Temperature

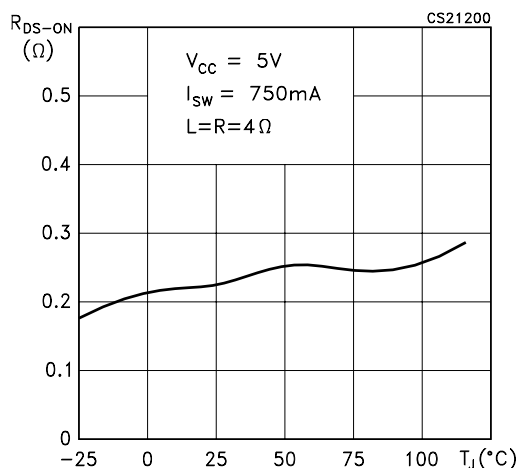

Figure 17: Switch Current Limitation vs Temperature

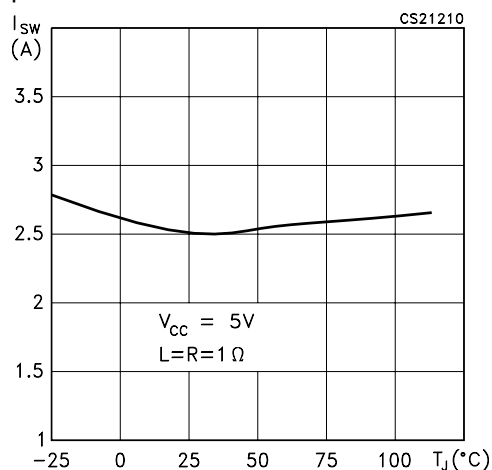
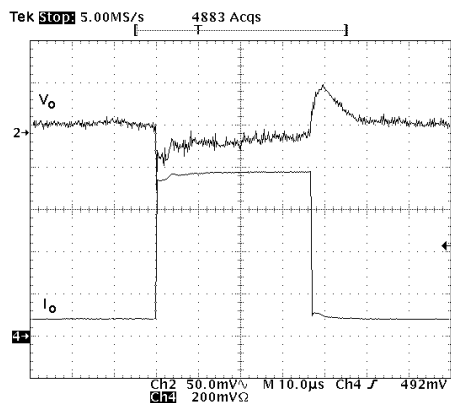
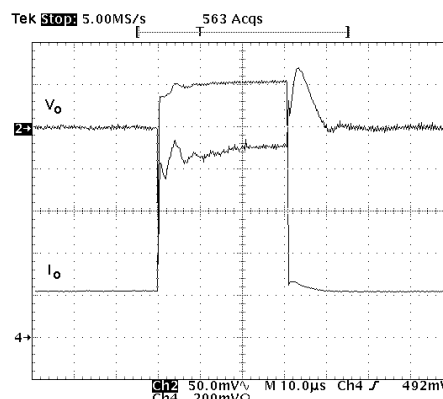

Figure 18: Load Transient Response



$V_{CC}=5V$, $I_O=100mA$ to $780mA$, $C_I=4.7\mu F$, $C_O=22\mu F$, $L=3.3\mu H$, $T_{ON}=38\mu s$, $T_J=25^\circ C$

Figure 19: Load Transient Response



$V_{CC}=5V$, $I_O=200mA$ to $1.2A$, $C_I=4.7\mu F$, $C_O=22\mu F$, $L=3.3\mu H$, $T_{ON}=38\mu s$, $T_J=25^\circ C$

Figure 20: Start-Up Transient

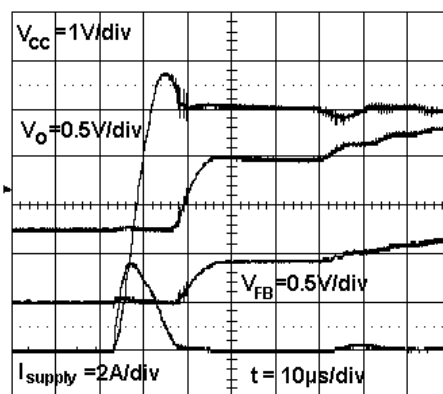

$V_{CC} = 5V$, $T_J = 25^\circ C$

Figure 21: Start-Up Transient

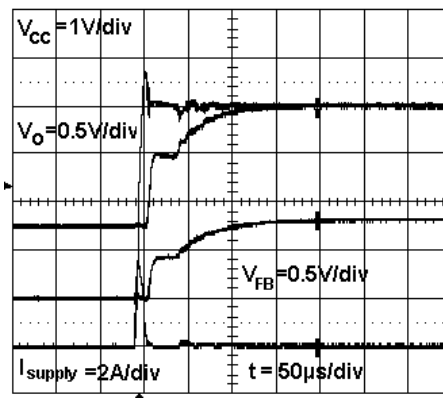

$V_{CC} = 7V$, $T_J = 25^\circ C$

DFN6 (3x3) MECHANICAL DATA

DIM.	mm.			inch		
	MIN.	TYP	MAX.	MIN.	TYP.	MAX.
A	0.80		1.00	31.5		39.4
A1	0		0.05	0.0		2.0
A2	0.65		0.75	25.6		29.5
A3		0.20			7.9	
b	0.33		0.43	13.0		16.9
D	2.90	3.00	3.10	114.2	118.1	122.0
D2	1.92		2.12	75.6		83.5
E	2.90	3.00	3.10	114.2	118.1	122.0
E2	1.11		1.31	43.7		51.6
e		0.95			37.4	
L	0.20		0.45	7.9		17.7
L1		0.24			9.4	
L2			0.13			5.1
K	0.20			7.9		

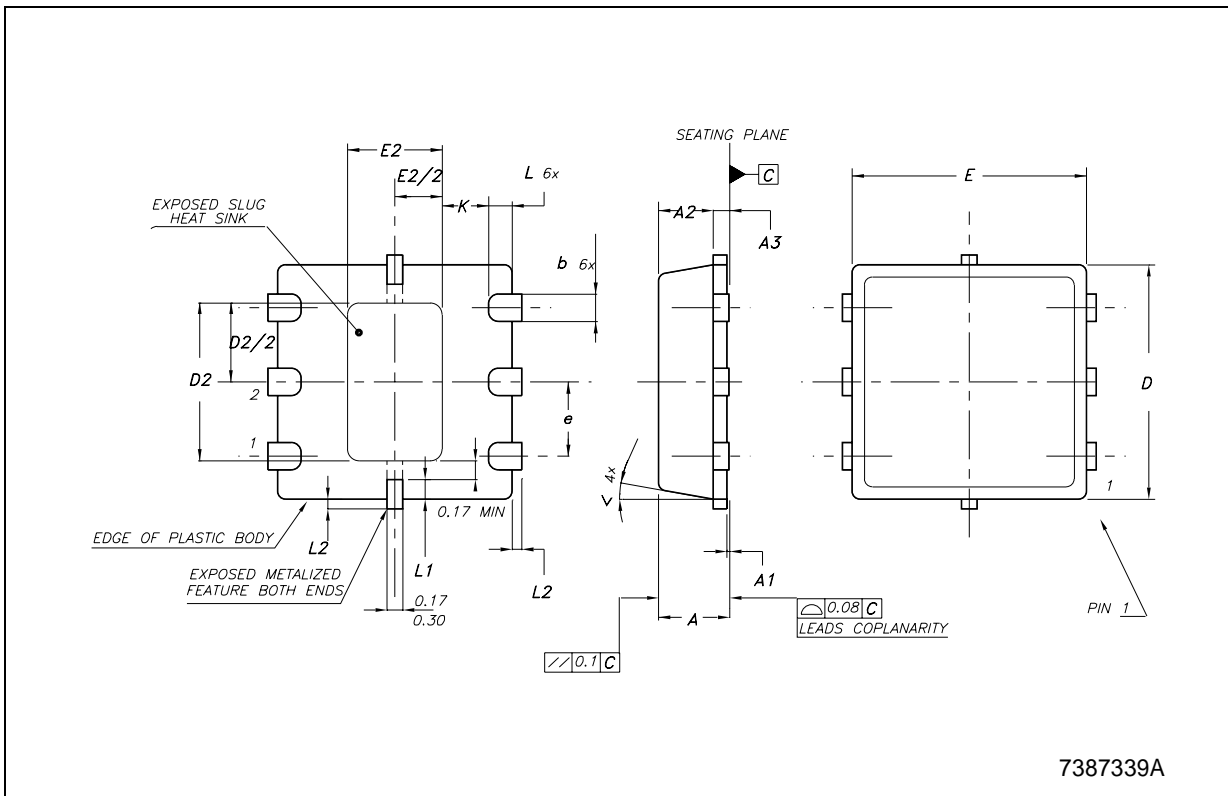

7387339A

Tape & Reel QFNxx/DFNxx (3x3) MECHANICAL DATA

DIM.	mm.			inch		
	MIN.	TYP.	MAX.	MIN.	TYP.	MAX.
A			330			12.992
C	12.8		13.2	0.504		0.519
D	20.2			0.795		
N	99		101	3.898		3.976
T			14.4			0.567
Ao		3.3			0.130	
Bo		3.3			0.130	
Ko		1.1			0.043	
Po		4			0.157	
P		8			0.315	

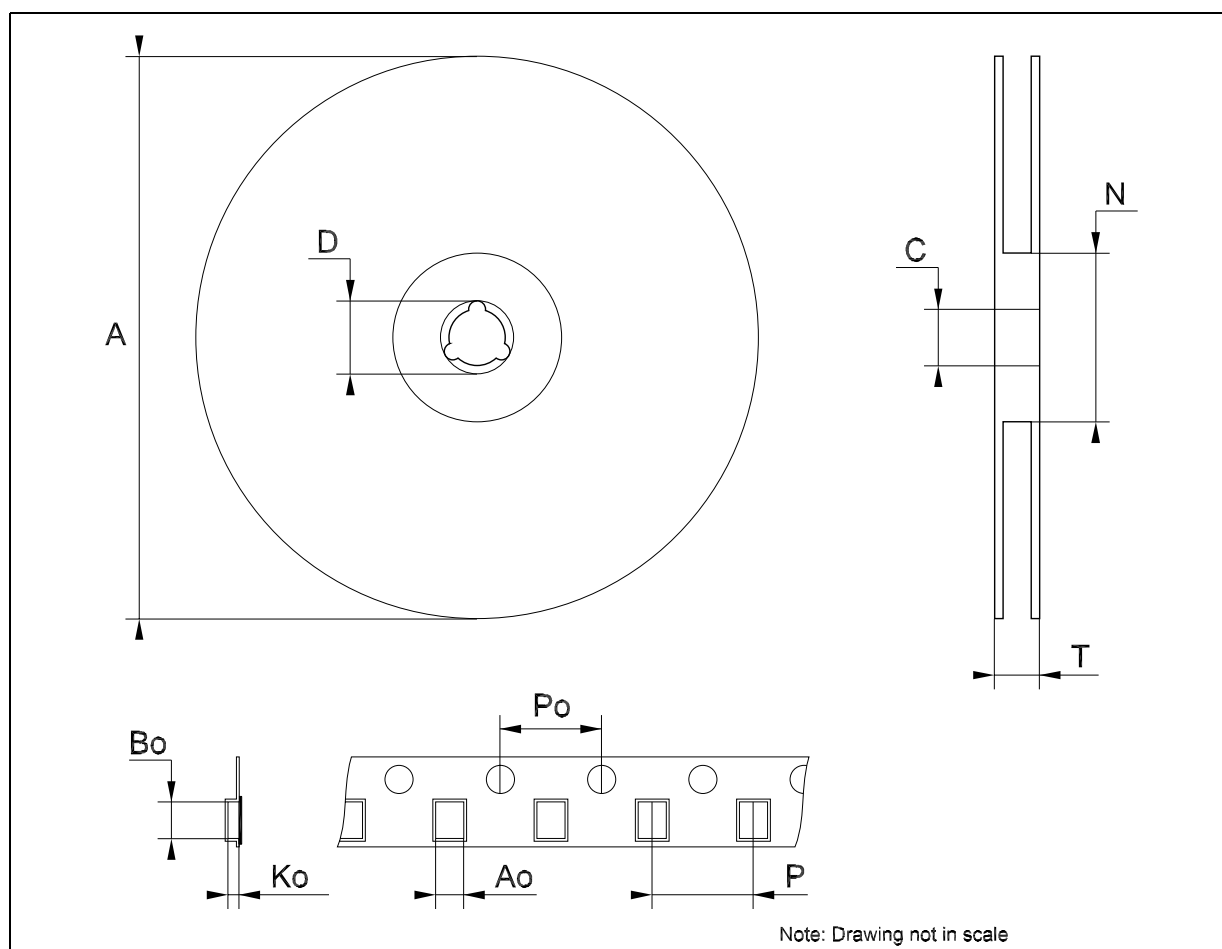

ST1S03

Table 6: Revision History

Date	Revision	Description of Changes
11-Nov-2004	1	First Release.
08-Feb-2005	2	Maturity Change.
03-Mar-2005	3	Mistake on Figure 1, T _J is changed 125 ==> 150°C on Table 3.

Information furnished is believed to be accurate and reliable. However, STMicroelectronics assumes no responsibility for the consequences of use of such information nor for any infringement of patents or other rights of third parties which may result from its use. No license is granted by implication or otherwise under any patent or patent rights of STMicroelectronics. Specifications mentioned in this publication are subject to change without notice. This publication supersedes and replaces all information previously supplied. STMicroelectronics products are not authorized for use as critical components in life support devices or systems without express written approval of STMicroelectronics.

The ST logo is a registered trademark of STMicroelectronics

All other names are the property of their respective owners

© 2005 STMicroelectronics - All Rights Reserved

STMicroelectronics group of companies

Australia - Belgium - Brazil - Canada - China - Czech Republic - Finland - France - Germany - Hong Kong - India - Israel - Italy - Japan - Malaysia - Malta - Morocco - Singapore - Spain - Sweden - Switzerland - United Kingdom - United States of America

www.st.com