

LINEAR SYSTEMS

Linear Integrated Systems

2N/SST4416 2N4416A

**N-CHANNEL JFET
HIGH FREQUENCY AMPLIFIER**

| FEATURES | |
|--|----------------|
| Direct Replacement For SILICONIX 2N/SST4416 & 2N4416A | |
| VERY LOW NOISE FIGURE (400 MHz) | 4 dB (max) |
| EXCEPTIONAL GAIN (400 MHz) | 10 dB (min) |
| ABSOLUTE MAXIMUM RATINGS ¹ @ 25 °C (unless otherwise stated) | |
| Maximum Temperatures | |
| Storage Temperature | -65 to +200 °C |
| Operating Junction Temperature | -55 to +135 °C |
| Maximum Power Dissipation | |
| Continuous Power Dissipation | 300mW |
| Maximum Currents | |
| Gate Current | 10mA |
| Maximum Voltages | |
| Gate to Drain or Gate to Source LS4416 | -30V |
| Gate to Drain or Gate to Source LS4416A | -35V |

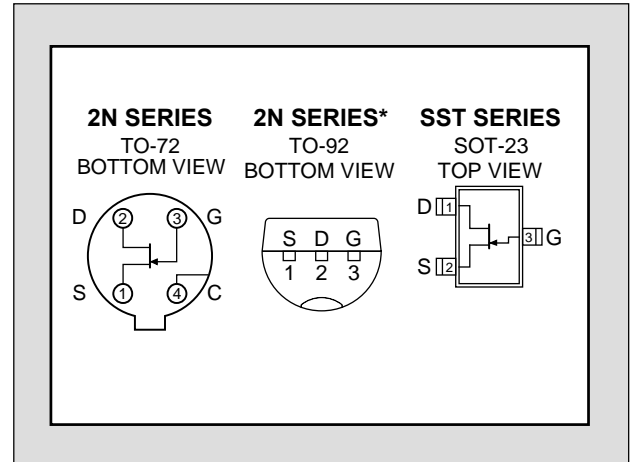

*Optional Package For 2N4416

ELECTRICAL CHARACTERISTICS @ 25 °C (unless otherwise stated)

| SYMBOL | CHARACTERISTIC | MIN | TYP | MAX | UNITS | CONDITIONS | |
|----------------------|---|------------|------|------|--------|---|--|
| BV _{GSS} | Gate to Source Breakdown Voltage | 2N/SST4416 | -30 | | | V | I _G = -1μA, V _{DS} = 0V |
| | | 2N4416A | -35 | | | | |
| V _{GS(off)} | Gate to Source Cutoff Voltage | 2N/SST4416 | | -6 | | V | V _{DS} = 15V, I _D = 1nA |
| | | 2N4416A | -2.5 | -6 | | | |
| I _{DSS} | Gate to Source Saturation Current | 5 | | 15 | mA | V _{DS} = 15V, V _{GS} = 0V | |
| I _{GSS} | Gate Leakage Current | 2N | | -0.1 | | nA | V _{GS} = -20V, V _{DS} = 0V |
| | | SST | | -1.0 | | | V _{GS} = -15V, V _{DS} = 0V |
| g _{fs} | Forward Transconductance | 4500 | | 7500 | μS | V _{DS} = 15V, V _{GS} = 0V, f = 1kHz | |
| g _{os} | Output Conductance | | | 50 | μS | | |
| C _{iss} | Input Capacitance ² | | | 0.8 | pF | V _{DS} = 15V, V _{GS} = 0V, f = 1MHz | |
| C _{rss} | Reverse Transfer Capacitance ² | | | 4 | | | |
| C _{oss} | Output Capacitance ² | | | 2 | | | |
| e _n | Equivalent Input Noise Voltage | | 6 | | nV/√Hz | V _{DS} = 10V, V _{GS} = 0V, f = 1kHz | |

HIGH FREQUENCY ELECTRICAL CHARACTERISTICS @ 25 °C (unless otherwise stated)

| SYMBOL | CHARACTERISTIC | 100 MHz | | 400 MHz | | UNITS | CONDITIONS |
|-----------|---------------------------------|---------|------|---------|-------|---------|---|
| | | MIN | MAX | MIN | MAX | | |
| g_{iss} | Input Conductance | | 100 | | 1000 | μS | $V_{DS} = 15V, V_{GS} = 0V$ |
| b_{iss} | Input Susceptance ² | | 2500 | | 10000 | | |
| g_{oss} | Output Conductance | | 75 | | 100 | | |
| b_{oss} | Output Susceptance ² | | 1000 | | 4000 | | |
| G_{fs} | Forward Transconductance | | | 4000 | | | |
| G_{ps} | Power Gain ² | 18 | | 10 | | dB | $V_{DS} = 15V, I_D = 5mA$ |
| NF | Noise Figure ² | | 2 | | 4 | | $V_{DS} = 15V, I_D = 5mA, R_G = 1k\Omega$ |

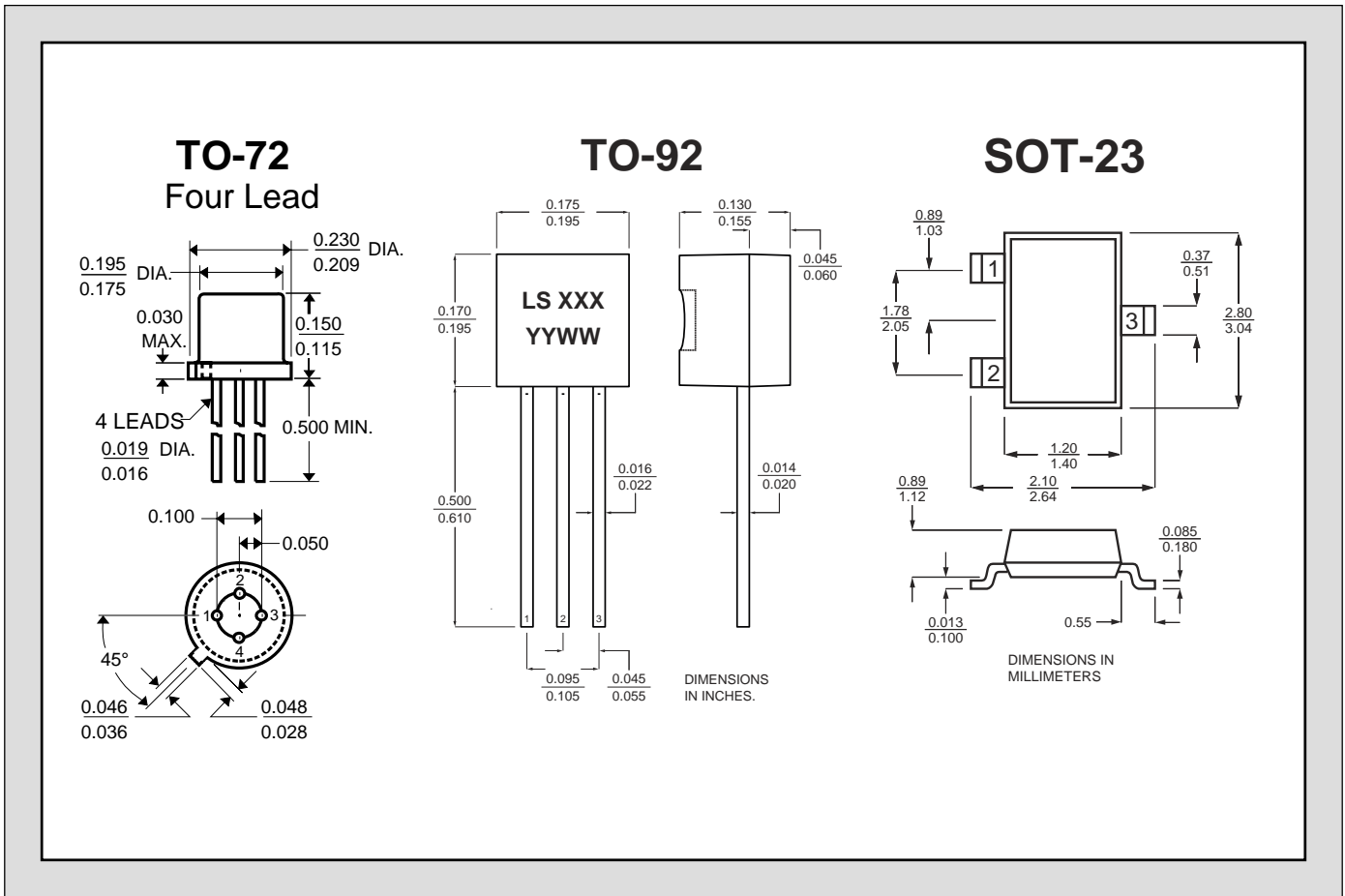

1. Absolute maximum ratings are limiting values above which serviceability may be impaired.
2. Not production tested, guaranteed by design.

Information furnished by Linear Integrated Systems is believed to be accurate and reliable. However, no responsibility is assumed for its use; nor for any infringement of patents or other rights of third parties which may result from its use. No license is granted by implication or otherwise under any patent or patent rights of Linear Integrated Systems.

Copyright © Each Manufacturing Company.

All Datasheets cannot be modified without permission.

This datasheet has been download from :

www.AllDataSheet.com

100% Free DataSheet Search Site.

Free Download.

No Register.

Fast Search System.

www.AllDataSheet.com