

General Description

The AAT4601 SmartSwitch™ is part of AnalogicTech's Application Specific Power MOSFET™ (ASPM™) product family. It is a 1.5A Current Limited P-channel MOSFET power switch designed for high-side load-switching applications. This switch operates with inputs ranging from 2.7V to 5.5V, making it ideal for both 3V and 5V systems. An integrated current-limiting circuit protects the input supply against large changes in load current which could cause the supply to fall out of regulation. The AAT4601 has protection from thermal overload which limits power dissipation and junction temperatures. The maximum current limit level is 1.5A; the actual threshold is programmed with a resistor from the SET pin to ground. The quiescent supply current is typically 12µA. In shutdown mode, the supply current decreases to less than 1µA.

The AAT4601 is available in 8-pin SOP or TSSOP specified over -40 to 85°C.

Features

- 2.7V to 5.5V Input voltage range
- Programmable over current threshold
- Low quiescent current
 - 12µA typical
 - Less than 1µA with Switch off
- Only 2.5V needed for ON Control
- Thermal Shutdown
- Fault Flag
- 2ms Fault Blanking
- Undervoltage Lockout
- Temperature range -40 to 85°C
- 2kV ESD rating
- UL Approved—File No. E217765
- 8-pin SOP or TSSOP package

Applications

- USB ports
- Notebook computers
- Peripheral ports
- Hot swap supplies



UL Recognized Component

Preliminary Information

Typical Application

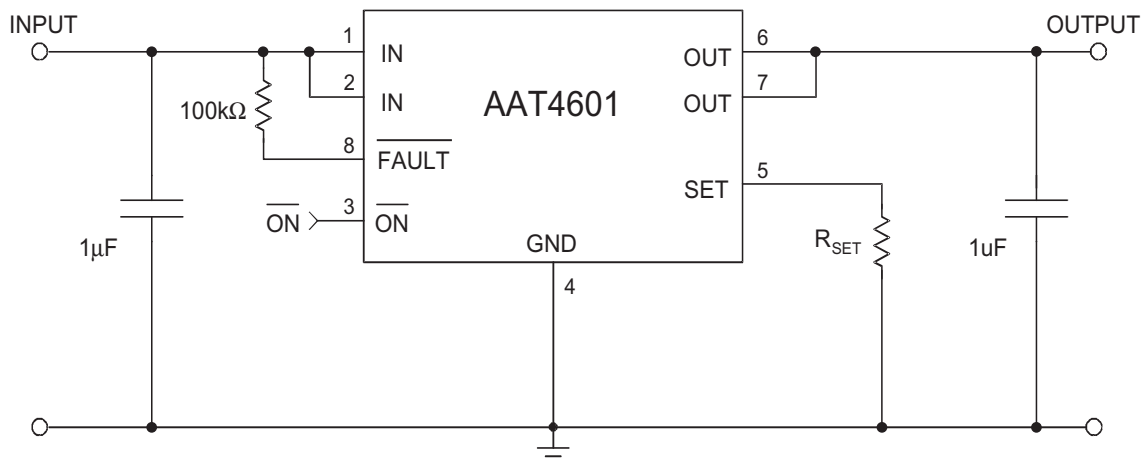

Pin Descriptions

Pin #	Symbol	Function
1,2	IN	These pins are the input to the P-channel MOSFET source. Connect a 1μF capacitor from IN to GND.
3	$\overline{\text{ON}}$	Active-Low Enable Input. A logic low turns the switch on.
4	GND	Ground
5	SET	Current-Limit Set Input. A resistor from SET to ground sets the current limit for the switch.
6,7	OUT	These pins are the P-channel MOSFET drain connection. Connect a 1μF capacitor from OUT to GND.
8	$\overline{\text{FAULT}}$	Fault-Indication Output. This open-drain output goes low when in current limit or when the die temperature exceeds +135 °C, with a 2ms delay after the fault event occurs.

Pin Configuration

**SOP-8/TSSOP-8
(Top View)**

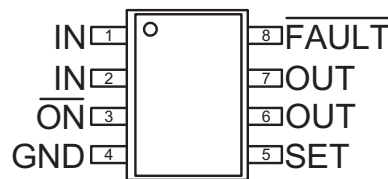

Absolute Maximum Ratings ($T_A=25^\circ\text{C}$ unless otherwise noted)

Symbol	Description	Value	Units
V_{IN}	IN to GND	-0.3 to 6	V
V_{ON}, V_{FAULT}	ON, FAULT to GND	-0.3 to $V_{IN}+0.3$	V
V_{SET}, V_{OUT}	SET, OUT to GND	-0.3 to $V_{IN}+0.3$	V
I_{MAX}	Maximum Continuous Switch Current	3	A
T_J	Operating Junction Temperature Range	-40 to 150	$^\circ\text{C}$
T_{LEAD}	Maximum Soldering Temperature (at Leads)	300	$^\circ\text{C}$
V_{ESD}	ESD Rating—HBM ¹	4000	V

Note: Stresses above those listed in Absolute Maximum Ratings may cause permanent damage to the device. Functional operation at conditions other than the operating conditions specified is not implied. Only one Absolute Maximum rating should be applied at any one time.

Note 1: Human body model is a 100pF capacitor discharged through a 1.5k Ω resistor into each pin.

Thermal Characteristics

Symbol	Description	Value	Units
Θ_{JA}	Typical Thermal Resistance ²	100	$^\circ\text{C}/\text{W}$
P_D	Maximum Power Dissipation ²	1.25	W

Note 2: Mounted on an AATI demo board.

Electrical Characteristics ($V_{IN} = 5\text{V}$, $T_A = -40$ to 85°C unless otherwise noted. Typical values are at $T_A=25^\circ\text{C}$)

Symbol	Description	Conditions	Min	Typ	Max	Units
V_{IN}	Operation Voltage		2.7		5.5	V
I_Q	Quiescent Current	$V_{IN} = 5\text{V}$, $\overline{\text{ON}} = \text{GND}$, $I_{OUT} = 0$		12	30	μA
$I_{Q(OFF)}$	Off Supply Current	$\overline{\text{ON}} = \text{IN}$, $V_{IN} = 5.5\text{V}$.004	1	μA
$I_{SD(OFF)}$	Off Switch Current	$\overline{\text{ON}} = \text{IN}$, $V_{IN} = 5.5\text{V}$, $V_{OUT} = 0$.07	15	μA
V_{UVLO}	Undervoltage Lockout	Rising edge, 1% hysteresis,	2.0	2.3	2.7	V
$R_{DS(ON)}$	On-Resistance	$V_{IN}=5.0\text{V}$		70		m Ω
		$V_{IN}=4.5\text{V}$		75	130	m Ω
		$V_{IN}=3.0\text{V}$		80	150	m Ω
I_{LIM}	Current Limit	$R_{SET} = 2\text{k}\Omega$	510	715	920	mA
$I_{LIM(MIN)}$	Minimum Current Limit			250		mA
TSD	Shutdown Temperature	$V_{IN} = 5\text{V}$		125		$^\circ\text{C}$
V_{ONL}	$\overline{\text{ON}}$ Input Low Voltage				0.8	V
V_{ONH}	$\overline{\text{ON}}$ Input High Voltage	$V_{IN}=2.7\text{V}$ to 3.6V	2.0			V
		$V_{IN}=4.5\text{V}$ to 5.5V	2.4			V
I_{ONSINK}	$\overline{\text{ON}}$ Input leakage	$V_{ON} = 5.5\text{V}$		0.01	1	μA
V_{FAULTL}	$\overline{\text{FAULT}}$ Logic Output Low Voltage	$I_{SINK}=1\text{mA}$		0.08	0.4	V
I_{FSINK}	$\overline{\text{FAULT}}$ Logic Output High Leakage	$V_{\overline{\text{FAULT}}} = 5.5\text{V}$		0.05	1	μA
T_{RESP}	Current Limit Response Time	$V_{IN}=5\text{V}$		2		μs
T_{BLANK}	Fault Blanking Time after Turn-On			2		ms
T_{OFF}	Turn-Off Time ³	$V_{IN}=5\text{V}$			20	μs
T_{ON}	Turn-On Time ³	$V_{IN}=5\text{V}$			200	μs
OTMP	Over Temperature Shut Down			125		$^\circ\text{C}$

Note 3: Guaranteed by design.

Typical Characteristics

(Unless otherwise noted, $V_{IN} = 5V$, $T_A = 25^\circ C$)

Quiescent Current vs. Temperature

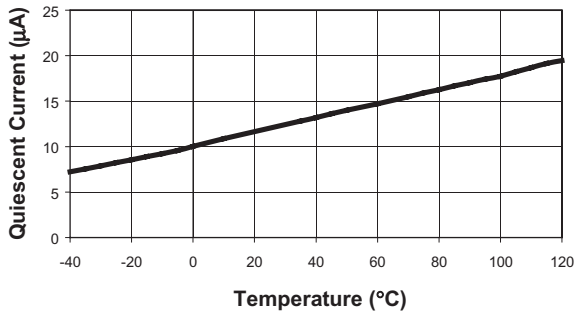

Quiescent Current

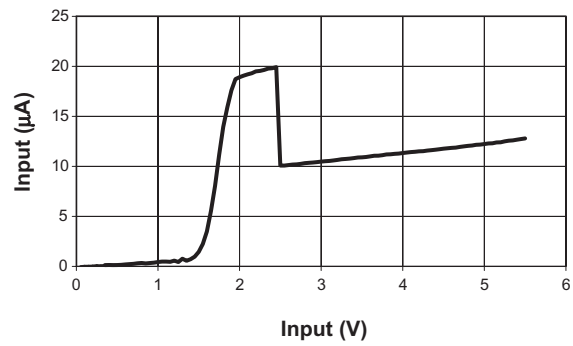

Current Limit

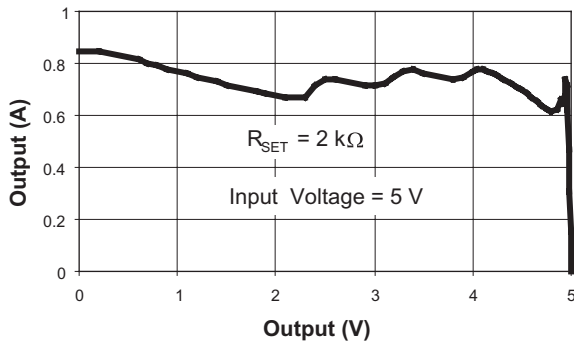

$R_{SET} I_{LIM}$ Product vs. I_{LIM}

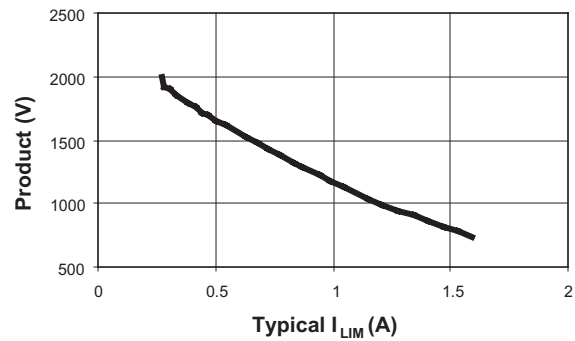

Off-Supply Current vs. Temperature

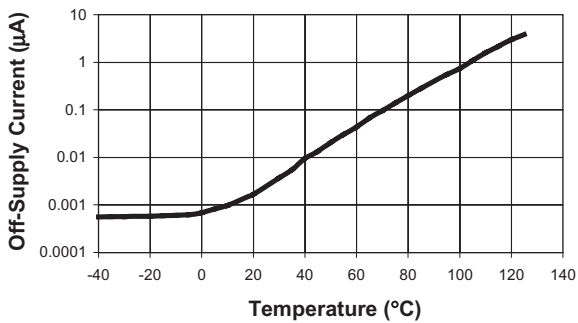

Off-Switch Current vs. Temperature

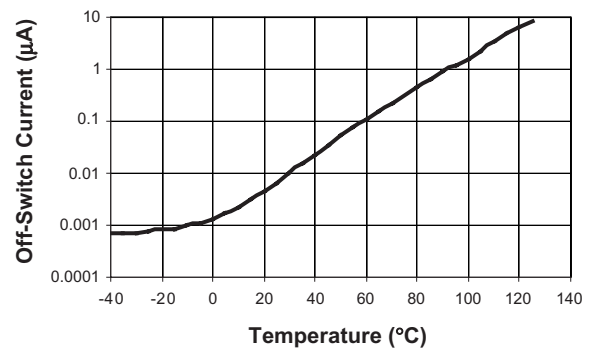

Typical Characteristics

(Unless otherwise noted, $V_{IN} = 5V$, $T_A = 25^\circ C$)

Turn-ON vs. Temperature

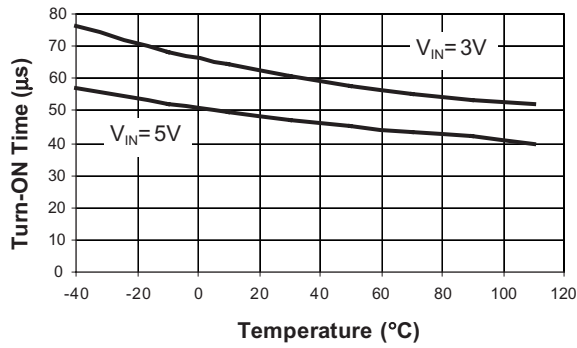

Turn-OFF vs. Temperature

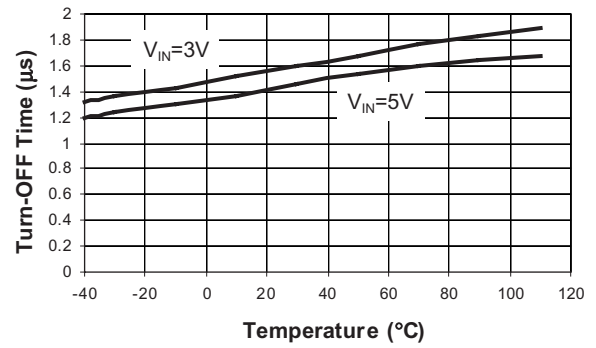

Switch Turn-On Time

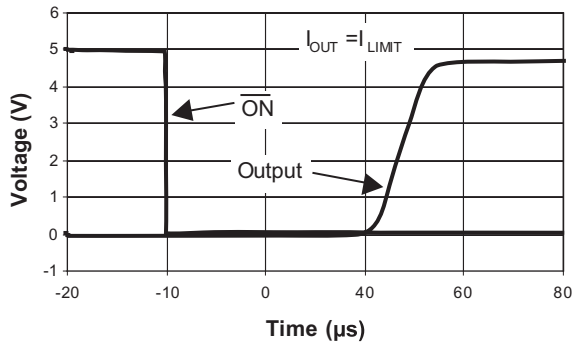

Switch Turn-Off Time

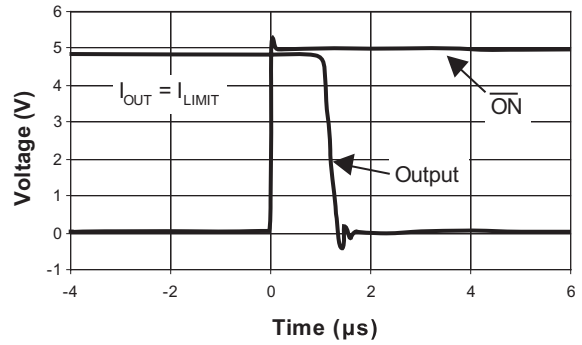

Short Circuit through 0.3Ω

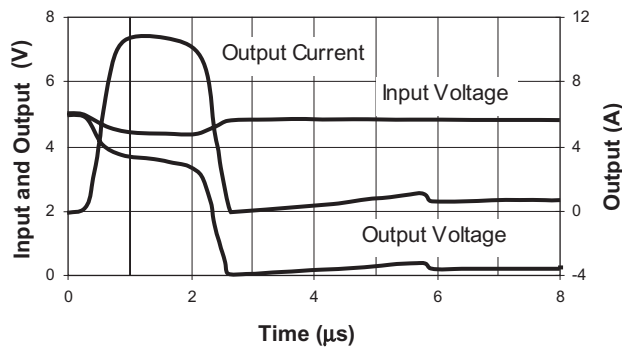

Short Circuit through 0.6Ω

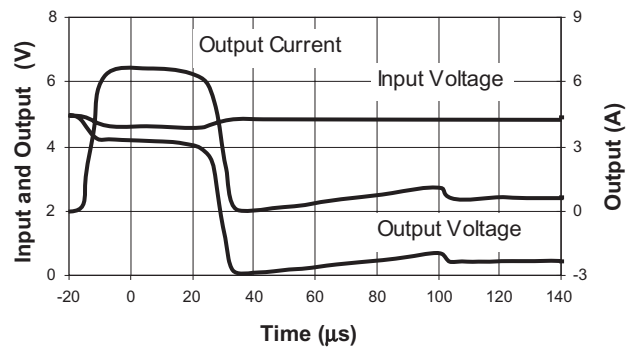

Typical Characteristics

(Unless otherwise noted, $V_{IN} = 5V$, $T_A = 25^\circ C$)

Fault Delay vs. Temperature

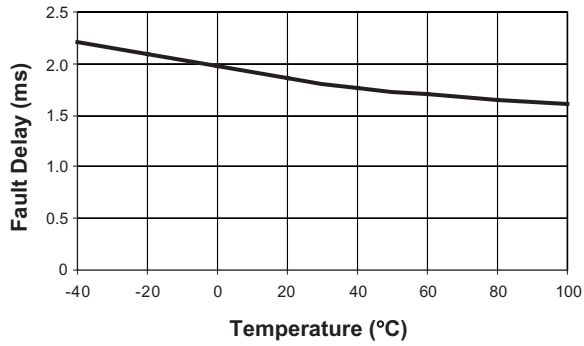

$R_{DS(ON)}$ vs. Temperature

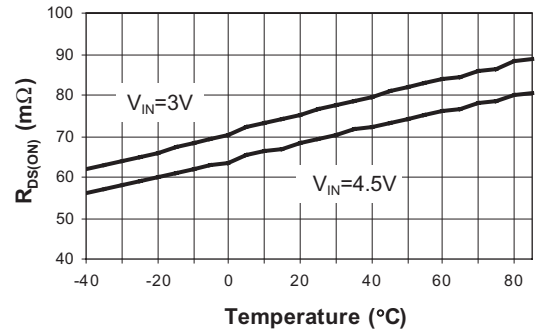

Functional Block Diagram

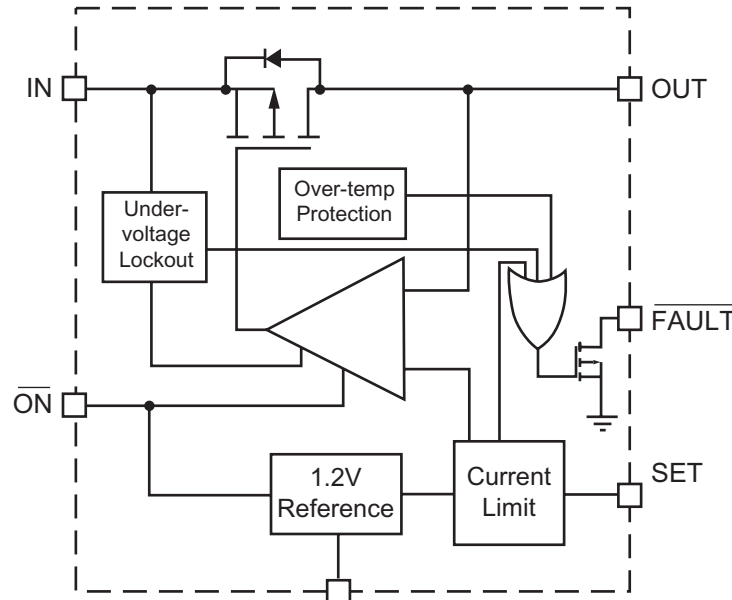

Functional Description

The AAT4601 is an integrated MOSFET load switch with an adjustable current limit, over temperature protection, level shifted input and a fault flag. The current limit control is combined with an over temperature thermal limit circuit to provide a comprehensive system to protect the load switch under short circuit or other adverse operating conditions. The AAT4601 is ideally suited for control and protection of peripheral ports such as USB, RS232 and parallel ports.

The current limit and over temperature circuits will act independently. The device current limit is activated when the output load current exceeds an internal threshold level. The internal current limit threshold is determined by an external resistor connected between the SET pin and ground. The minimum current limit threshold is specified by $I_{LIM(MIN)}$. If the load switch ambient temperature becomes excessive or if a short circuit condition

persists, the die temperature will rise causing the over temperature protection circuit to activate.

If the current limit or over temperature protection circuits are active for more than two milliseconds, the system will be informed via the FAULT Flag. The two millisecond delay allows the AAT4601 to be turned on into capacitive loads without activating the FAULT Flag. The open drain FAULT output can be connected directly to system controllers driven by voltage levels less than the IN pin voltage without additional level shifting circuitry.

The load switch is turned off by applying a logic high level to the ON pin. The AAT4601 typically consumes 12 μ A when operating, when off, the device draws less than 1 μ A. In the off state, current is prevented from flowing between the input and output. The ON function has logic level thresholds that allow the AAT4601 to be TTL compatible and may also be controlled by 2.5V to 5.0V CMOS circuits. The voltage level on either ON or FAULT should not exceed the input supply level present on the IN pin.

Applications Information

Setting Current Limit

A simple three-step procedure can be used to adjust the AAT4601's current limit. First, the maximum current required by the load should be determined. Second, select a resistor that guarantees adequate current is available to the load under normal conditions. Finally, the maximum current that can pass through the switch can be calculated and compared to the maximum current available.

Step 1: The maximum current required by a load is usually defined in port specifications design application references. For example, USB ports are specified to support loads of up to 500 mA.

Step 2: The most convenient method for determining a current limit resistor value is to look it up in the provided table named "Current Limit R_{SET} Values". Find the lowest current value that is greater than the maximum load current in the given application. Refer to the column named "Device will not current limit below". The resistor value needed is in the corresponding row named " R_{SET} ". For example, a USB port requires 500 mA. The lowest level where the device will current limit above 500 mA is 516 mA. The corresponding resistor value for R_{SET} would be 2k Ω .

Step 3: Now the required resistor value has been determined. The maximum current that can be drawn, even with a short circuit applied to the output, can be determined by reading the column labeled "Device always current limits below". If the power supply connected to the AAT4601's input can provide this current level, the power supply voltage will not collapse when a short circuit is applied to the load switch output. For example, a notebook computer has a USB port which is powered by an AAT4601 with a 2k Ω resistor connected between the SET pin and GND. If the power supply connected to the AAT4601's IN pin can provide more than 917 mA, this supply will remain in regulation even if a short circuit is applied to the USB port.

Current Limit R_{SET} Values

R_{SET} (Ω)	Current Limit typ (mA)	Device will not current limit below: (mA)	Device always current limits below: (mA)
470	1585	1141	2029
510	1529	1101	1957
560	1466	1055	1876
620	1397	1006	1788
680	1334	960	1707
750	1266	911	1620
820	1206	869	1544
910	1144	823	1464
1000	1089	784	1394
1100	1034	745	1324
1200	986	710	1262
1300	941	677	1204
1500	865	623	1107
1600	829	597	1061
1800	769	554	985
2000	716	516	917
2200	673	485	861
2400	633	456	811
2700	582	419	745
3000	539	388	690
3300	502	362	643
3600	470	339	602
3900	442	318	565
4300	410	295	524
4700	382	275	489
5100	358	258	458
5600	332	239	424
6200	306	220	392
6800	283	204	362
7500	268	193	343

Applications Information

Operation in Current Limit

If an excessive load is applied to the output of an AAT4601, the load's current will be limited by the AAT4601's current limit circuitry. Refer to the figure named "Overload Operation". If a short circuit were to occur on the load, it would demand more current than what is allowed by the internal current limiting circuit and the voltage at the AAT4601's output will drop. This causes the AAT4601 to dissipate more power than in normal operation, causing the die temperature to increase. When die temperature exceeds the internal over temperature threshold, the AAT4601 will shut down. After shutting down, the AAT4601 cools to a level below the over temperature threshold, at which point it will start up again. The AAT4601 will continue to cycle off and on until one of the following events occurs; the load current is reduced to a level below the AAT4601's current limit setting, the input power is removed, or until the output is turned off by a logic high level applied to the \overline{ON} pin.

Thermal Considerations

Since the AAT4601 has internal current limit and over temperature protection, junction temperature is rarely a concern. If an application requires a large load current in a high temperature operating environment, there is the possibility that the over temperature protection circuit rather than the current limit circuit will regulate the current available to the load. In these applications, the maximum current available without risk of activation of the over temperature circuit can be calculated. The maximum

internal temperature while current limit is not active can be calculated using Equation 1:

$$T_{J(MAX)} = I_{MAX}^2 \times R_{DS(ON)(MAX)} \times R_{\theta JA} + T_A(MAX)$$

In Equation 1, I_{MAX} is the maximum current required by the load. $R_{DS(ON)(MAX)}$ is the maximum rated $R_{DS(ON)}$ of the AAT4601 at high temperature. $R_{\theta JA}$ is the thermal resistance between the AAT4601's die and the board onto which it is mounted. $T_A(MAX)$ is the maximum ambient temperature for the printed circuit board assembly under the AAT4601 when the load switch is not dissipating power. Equation 1 can be transformed to provide I_{MAX} ; Refer to Equation 2.

$$I_{MAX} = \sqrt{\frac{T_{SD(MIN)} - T_A(MAX)}{R_{DS(ON)(MAX)} \times R_{\theta JA}}}$$

$T_{SD(MIN)}$ is the minimum temperature required to activate the AAT4601's over temperature protection. With typical specification of 125°C, 115°C is a safe minimum value to use.

For example, a portable device is specified to operate in a 50°C environment. The printed circuit board assembly will operate at temperatures as high as 85°C. This portable device has a sealed case and the area of the printed board assembly is relatively small causing $R_{\theta JA}$ to be approximately 120°C/W. Using Equation 2,

$$I_{MAX} = \sqrt{\frac{115 - 85}{130 \times 120}} = 1.4 \text{ A}$$

If this system requires less than 1.4 A, the thermal limit will not activate during normal operation.

Overload Operation

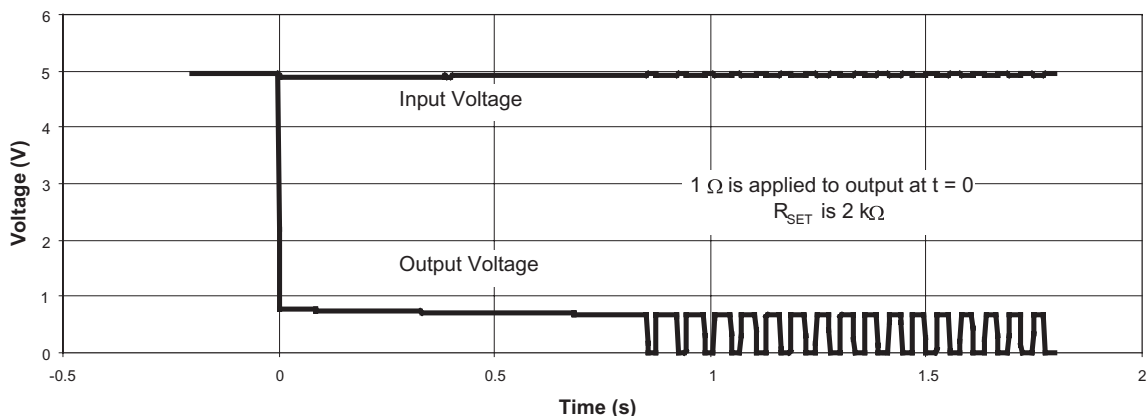

Applications Information

Input Capacitor

The input capacitor serves two purposes. First, it protects the source power supply from transient current effects generated by the application load circuit. If a short circuit is suddenly applied to the output of an AAT4601, there is a microsecond long period during which a large can current flow before the current limit circuitry activates. Refer to the characteristic curve named "Short Circuit Through 0.3Ω." A properly sized input capacitor can dramatically reduce the load switch input transient response effects seen by the power supply and other circuitry upstream from the AAT4601.

The second purpose of the input capacitor is to prevent transient events generated by the load circuit from affecting the operation of the AAT4601. For example, if an AAT4601 is used in a circuit that operates from a 3 volt power supply with poor step load response, it is possible that turning on the load switch could cause the input power supply to droop below the AAT4601's under voltage lockout threshold. This drop in voltage would cause the AAT4601 to turn off until the input power supply's voltage recovers. Since this cycle would be self-perpetuating, the entire circuit could be seen to be unstable. In the very rare case where capacitor cost is prohibitive, the output load circuit should be slew rate limited when turned on.

Output Capacitor

In order to insure stability while the device current limit is active, a small capacitance of approximately 1μF should be used. When the AAT4601 is activated using the \overline{ON} function, there are no momentary current transients as in the case of when a short circuit suddenly applied to a device that is already on. Refer to the characteristic curve named "Switch Turn-On Time." No matter how big the output capacitor, output current is limited to the value allowed by the threshold determined by R_{SET} and the internal current limiting circuitry. This permits very large output capacitors to be used.

For example, USB ports are specified to have at least 120μF of down stream capacitance from their controlling power switch. An output capacitance as large as 1000μF would not disturb the input power supply to the AAT4601 used to control the USB port.

\overline{ON} Input

When the AAT4601 is in the off state, the output is an open circuit and the device quiescent current consumption is reduced to less than 1μA. The \overline{ON} threshold voltage is set to allow the AAT4601 to be controlled by 5 volt TTL levels as well as CMOS power from 2.5 volts to 5 volts. The \overline{ON} function control voltage level should not exceed the input supply level applied to the IN pin.

FAULT Output

A \overline{FAULT} flag is provided to alert a system if the load switch is not receiving a sufficient voltage level to operate properly. If either the current limit or over temperature circuits in any combination are active for more than approximately two milliseconds continuously, the \overline{FAULT} pin is pulled to ground internally through a 100Ω resistance. The 2 millisecond delay on the \overline{FAULT} function is intended to prevent capacitive loads connected to the load switch output from activating \overline{FAULT} when the device is turned on. The placement of a pull up resistor between the \overline{FAULT} pin and the IN pin is recommended. Reasonable values for the pull up resistor should range from 10kΩ to 100kΩ. Since \overline{FAULT} is an open drain terminal, it may be pulled up to any voltage that is not greater than the level present on the IN pin. This is done to allow the AAT4601 to signal ancillary circuitry that is powered by voltage level less than the level on the IN pin.

Reverse Voltage

The AAT4601 is designed to control current flowing from IN to OUT. If a voltage is applied to OUT which is greater than that on IN, a large resulting reverse current may flow, potentially damaging the AAT4601.

Printed Circuit Board Layout Recommendations

For proper thermal management, and to take advantage of the low $R_{DS(ON)}$ of the AAT4601, a few circuit board layout rules should be followed: V_{IN} and V_{OUT} should be routed using wider than normal traces, and GND should be connected to a ground plane. For best performance, C_{IN} and C_{OUT} should be placed close to the package pins.

Evaluation Board Layout

The AAT4601 evaluation layout follows the printed circuit board layout recommendations, and can be used for good applications layout.

Note: Board layout shown is not to scale.

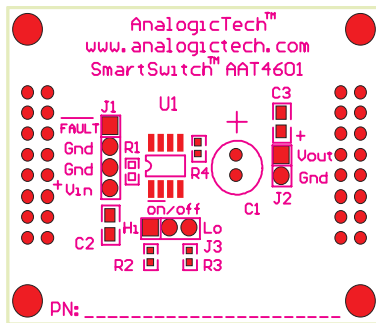

Figure 1: AAT4601 Evaluation board top side silk screen assembly drawing

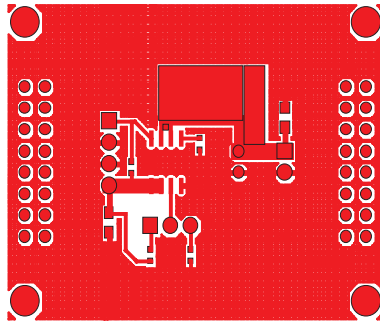

Figure 2: AAT4601 Evaluation board component side layout

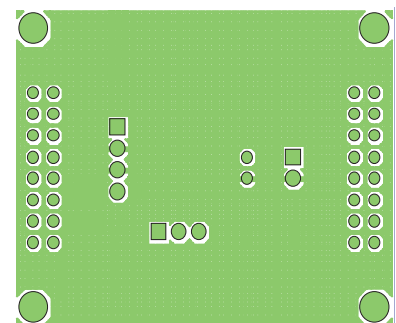

Figure 3: AAT4601 Evaluation board solder side layout

Ordering Information

Package	Marking	Part Number	
		Bulk	Tape and Reel
SOP-8		AAT4601IAS-B1	AAT4601IAS-T1
TSSOP-8		AAT4601IHS-B1	AAT4601IHS-T1

Package Information

SOP-8

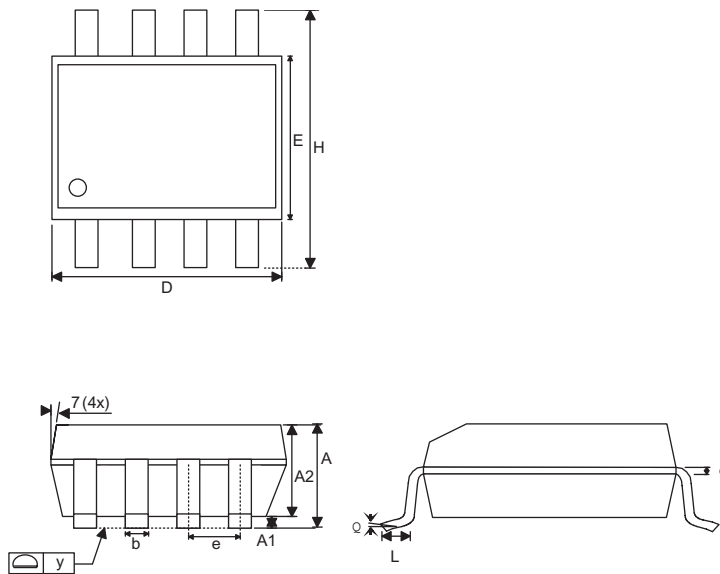

Dim	Millimeters		Inches	
	Min	Max	Min	Max
A	1.35	1.75	0.053	0.069
A1	0.10	0.25	0.004	0.010
A2	1.45		0.057	
B	0.33	0.51	0.013	0.020
C	0.19	0.25	0.007	0.010
D	4.80	5.00	0.189	0.197
E	3.80	4.00	0.150	0.157
e	1.27		0.050	
H	5.80	6.20	0.228	0.244
L	0.40	1.27	0.016	0.050
Y	0.00	0.10	0.000	0.004
θ1	0°	8°	0°	8°

Note:

1. PACKAGE BODY SIZES EXCLUDE MOLD FLASH PROTRUSIONS OR GATE BURRS.
2. TOLERANCE $\pm 0.1000\text{mm}$ (4mil) UNLESS OTHERWISE SPECIFIED
3. COPLANARITY: 0.1000mm
4. DIMENSION L IS MEASURED IN GAGE PLANE.
5. CONTROLLING DIMENSION IS MILLIMETER; CONVERTED INCH DIMENSIONS ARE NOT NECESSARILY EXACT.

TSSOP-8

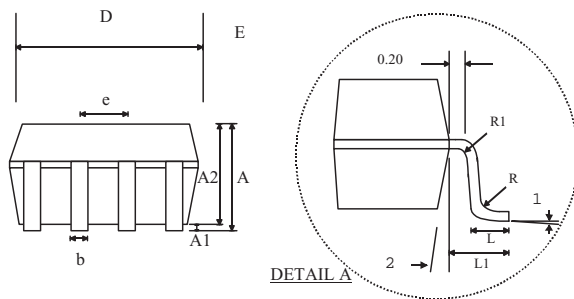
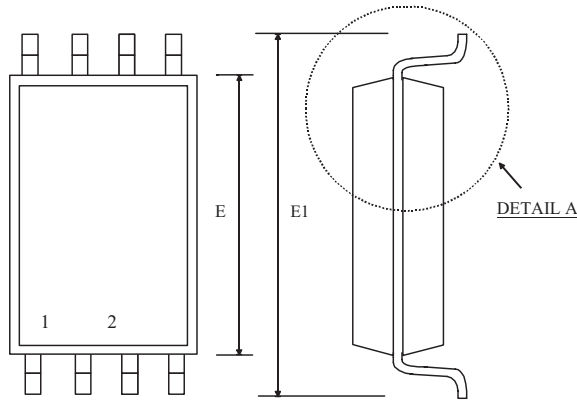

Dim	Millimeters		Inches	
	Min	Max	Min	Max
A	1.05	1.20	0.041	0.047
A1	0.05	0.15	0.002	0.006
A2	-	1.05	-	0.041
b	0.25	0.30	0.010	0.012
c	0.127		0.005	
D-8	2.90	3.10	0.114	0.122
D-28	9.60	9.80	0.378	0.386
E	4.30	4.50	0.170	0.177
E1	6.20	6.60	0.244	0.260
e	0.65 BSC		0.025 BSC	
L	0.50	0.70	0.020	0.028
L1	1.0		0.039	
R	0.09	-	0.004	-
R1	0.09	-	0.004	-
θ1	0°	8°	0°	8°
θ2	12°			

This page intentionally left blank.

Copyright © Each Manufacturing Company.

All Datasheets cannot be modified without permission.

This datasheet has been download from :

www.AllDataSheet.com

100% Free DataSheet Search Site.

Free Download.

No Register.

Fast Search System.

www.AllDataSheet.com