

TOSHIBA CMOS DIGITAL INTEGRATED CIRCUIT SILICON MONOLITHIC

T6A41

COLUMN DRIVER LSI FOR A DOT MATRIX LCD

The T6A41 is a column driver with 64-output channels for a medium- or small-scale dot matrix LCD.

The T6A41 realizes low power LCD systems using the CMOS Si-Gate process.

The T6A41 has two bi-directional data Input/Output pins and three types of data flow (pin program) :

- ① O₁→O₆₄, ② O₆₄→O₁, ③ O₁→O₃₂, O₆₄→O₃₃.

FEATURES

- 64-output column driver
- Three types of data flow (bi-directional) ;
 - ① O₁→O₆₄
 - ② O₆₄→O₁
 - ③ O₁→O₃₂, O₆₄→O₃₃
- High speed operation
- Low power consumption
- Power supply : 5V ± 10%
- 92-pin plastic flat package

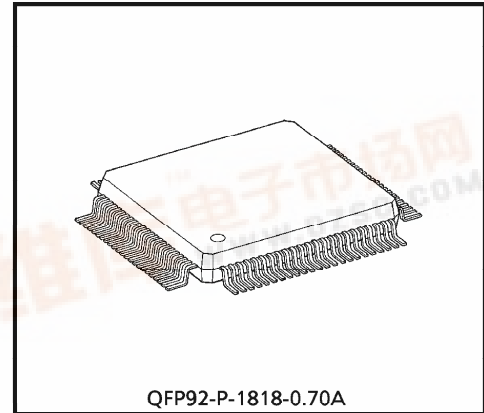

Weight: 1.4g (typ.)

BLOCK DIAGRAM

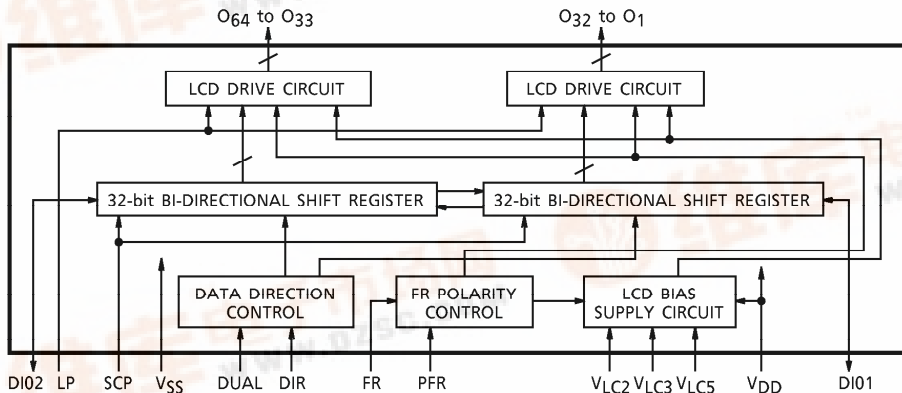

961001EBA2

● TOSHIBA is continually working to improve the quality and the reliability of its products. Nevertheless, semiconductor devices in general can malfunction or fail due to their inherent electrical sensitivity and vulnerability to physical stress. It is the responsibility of the buyer, when utilizing TOSHIBA products, to observe standards of safety, and to avoid situations in which a malfunction or failure of a TOSHIBA product could cause loss of human life, bodily injury or damage to property. In developing your designs, please ensure that TOSHIBA products are used within specified operating ranges as set forth in the most recent products specifications. Also, please keep in mind the precautions and conditions set forth in the TOSHIBA Semiconductor Reliability Handbook.

● The products described in this document are subject to foreign exchange and foreign trade control laws.

● The information contained herein is presented only as a guide for the applications of our products. No responsibility is assumed by TOSHIBA CORPORATION for any infringements of intellectual property or other rights of the third parties which may result from its use. No license is granted by implication or otherwise under any intellectual property or other rights of TOSHIBA CORPORATION or others.

● The information contained herein is subject to change without notice.



PIN ASSIGNMENT

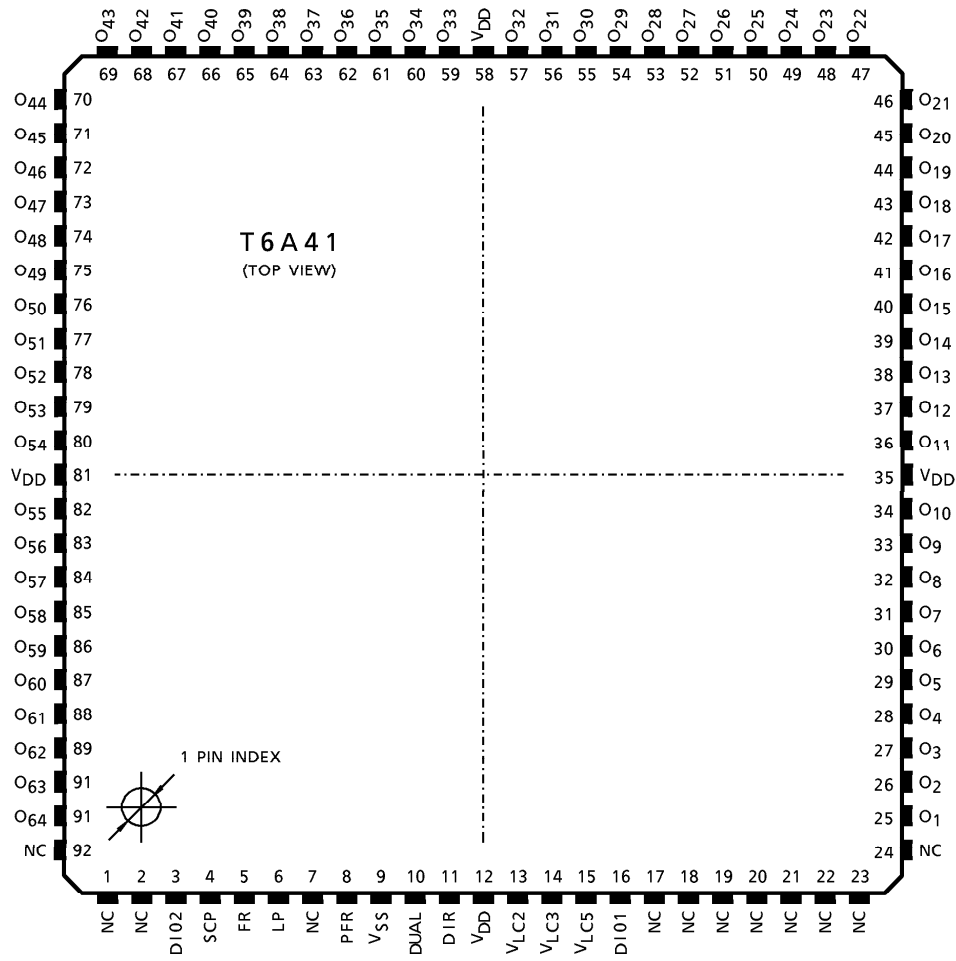

PIN FUNCTIONS

PIN NAME	I/O	FUNCTIONS	LEVEL					
O ₁ to O ₆₄	Output	LCD drive signal output	V _{DD} to V _{LC5}					
DIO1, DIO2	I/O	Bi-directional data input and output	V _{DD} to V _{SS}					
SCP	Input	(Shift Clock Pulse) Shift clock pulse input						
FR	Input	(Frame) Frame signal input						
LP	Input	(Latch Pulse) Latch pulse signal input						
DUAL	Input	(Dual Mode) Selects dual mode or single mode data flow.		DUAL	DIR	DIO1	DIO2	DATA DIRECTION
				L	L	OUT	IN	O ₆₄ →O ₁
				L	H	IN	OUT	O ₁ →O ₆₄
				H	L	—	—	Do not use
H	H	IN		IN	O ₁ →O ₃₂ , O ₆₄ →O ₃₃			
DIR	Input	(Direction) Selects input data flow direction.						
PFR	Input	(Polarity of Flame) Usually connected to V _{SS}						
V _{LC2}	—	Power supply for LCD drive	—					
V _{LC3}	—	Power supply for LCD drive						
V _{LC5}	—	Power supply for LCD drive						
V _{DD}	—	Power supply (5V)						
V _{SS}	—	Power supply (0V)						

TIMING DIAGRAM

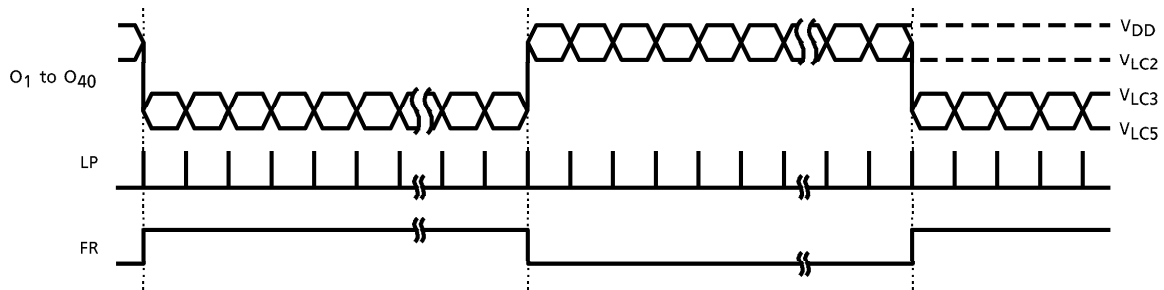

ABSOLUTE MAXIMUM RATINGS (Ta = 25°C)

ITEM	SYMBOL	RATING	UNIT
Supply Voltage (1)	V _{DD} (Note 1)	- 0.3 to 7.0	V
Supply Voltage (2)	V _{LC2} , V _{LC3} , V _{LC5} (Note1, 2)	- 0.3 to 7.0	V
Input Voltage	V _{IN} (Note 1)	- 0.3 to V _{DD} + 0.3	V
Operating Temperature	T _{opr}	- 20 to 75	°C
Storage Temperature	T _{stg}	- 55 to 125	°C

(Note 1) Referenced to V_{SS} = 0V

(Note 2) Ensure that the following condition is always maintained.

$$V_{DD} \geq V_{LC2} \geq V_{LC3} \geq V_{LC5}$$

ELECTRICAL CHARACTERISTICS

DC CHARACTERISTICS

TEST CONDITIONS (Unless otherwise noted, V_{SS} = 0V, V_{DD} = 5.0V ± 10%, V_{LC5} = 0V, Ta = - 20 to 75°C)

ITEM	SYMBOL	TEST CIR-CUIT	TEST CONDITIONS	MIN	TYP.	MAX	UNIT	PIN NAME	
Operating Voltage (1)	—	—	—	4.5	5.0	5.5	V	V _{DD}	
Operating Voltage (2)	—	—	—	0	—	V _{DD} - 3.0	V	V _{LC5}	
Input Voltage	H Level	V _{IH}	—	V _{DD} - 1.0	—	V _{DD}	V	(*)	
	L Level	V _{IL}	—	0	—	1.0	V	(*)	
Output Voltage	H Level	V _{OH}	I _{OH} = - 0.4mA	V _{DD} - 0.4	—	V _{DD}	V	DIO1, DIO2	
	L Level	V _{OL}	I _{OH} = 0.4mA	0	—	0.4	V	DIO1, DIO2	
Output Resistance	R _{COL}	—	I _d = ± 50μA	—	—	30	kΩ	O ₁ to O ₆₄	
Operating Frequency	f _{scp}	—	Ta = - 20 to 75°C	—	—	400	kHz	SCP	
Current Consumption	I _{SS}	—	V _{DD} = 5.0V V _{LC2} = 3.0V V _{LC3} = 2.0V V _{LC5} = 0.0V f _{FR} = 39Hz f _{scp} = 250kHz O ₁ to O ₆₀ : No Load	Binary Data Input	—	—	1.0	mA	V _{SS}
				Input Data : LOW Constant	—	—	0.4	mA	

(*) DIO1, DIO2, SCP, FR, LP, PFR, DUAL, DIR

AC CHARACTERISTICS

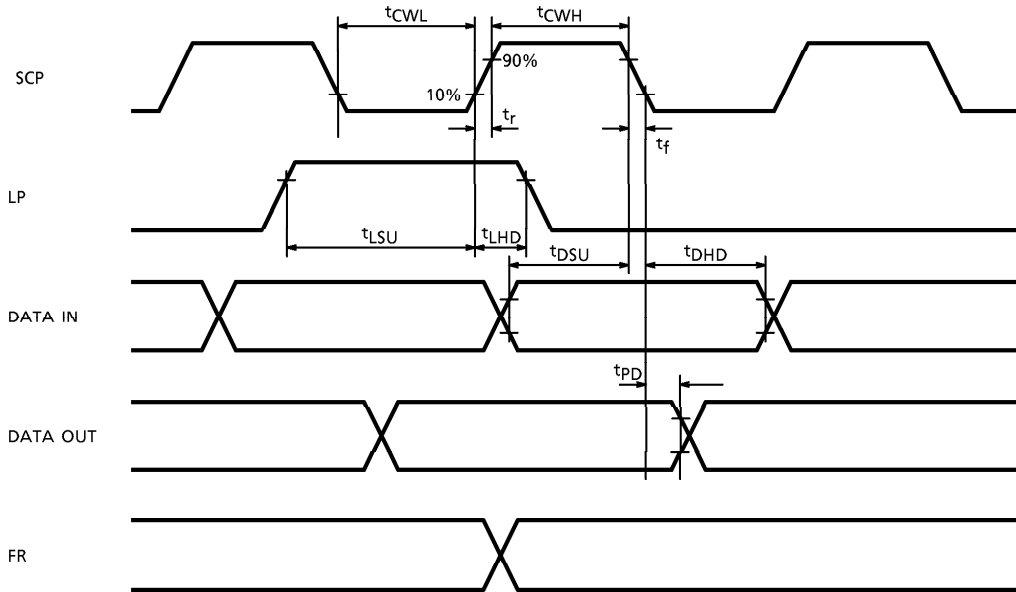

TEST CONDITIONS ($V_{SS} = 0V$, $V_{DD} = 5V \pm 10\%$, $V_{LC5} = 0V$, $T_a = -20$ to $75^\circ C$)

ITEM	SYMBOL	MIN	MAX	UNIT
Operating Frequency	f_{scp}	—	400	kHz
SCP Pulse Width	t_{CWH}, t_{CWL}	800	—	ns
SCP Rise / Fall Time	t_r, t_f	—	200	ns
LP Set-up Time	t_{LSU}	500	—	ns
LP Hold Time	t_{LHD}	—	10	ns
Data Set-up Time	t_{DSU}	300	—	ns
Data Hold Time	t_{DHD}	300	—	ns
Output Data Delay Time	t_{PD} (Note)	—	500	ns

LOAD CIRCUIT

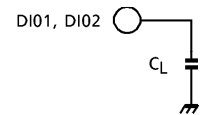

$C_L = 50pF$
(including wiring capacitance)

(Note) With load circuit connected

APPLICATION CIRCUIT

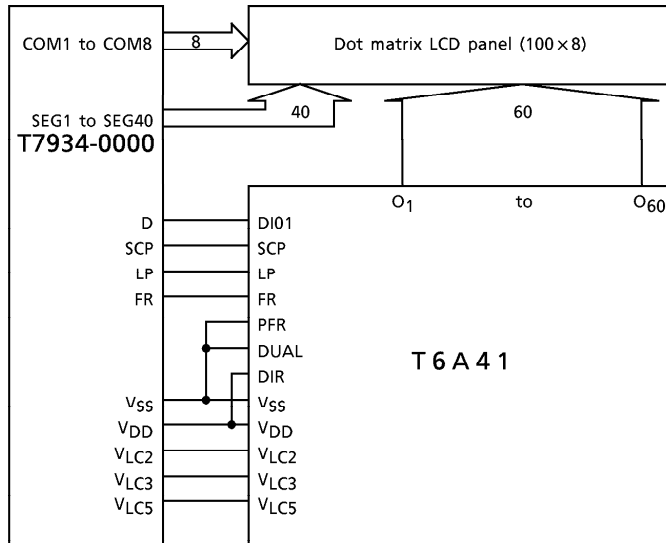

OUTLINE DRAWING
QFP92-P-1818-0.70A

Unit : mm

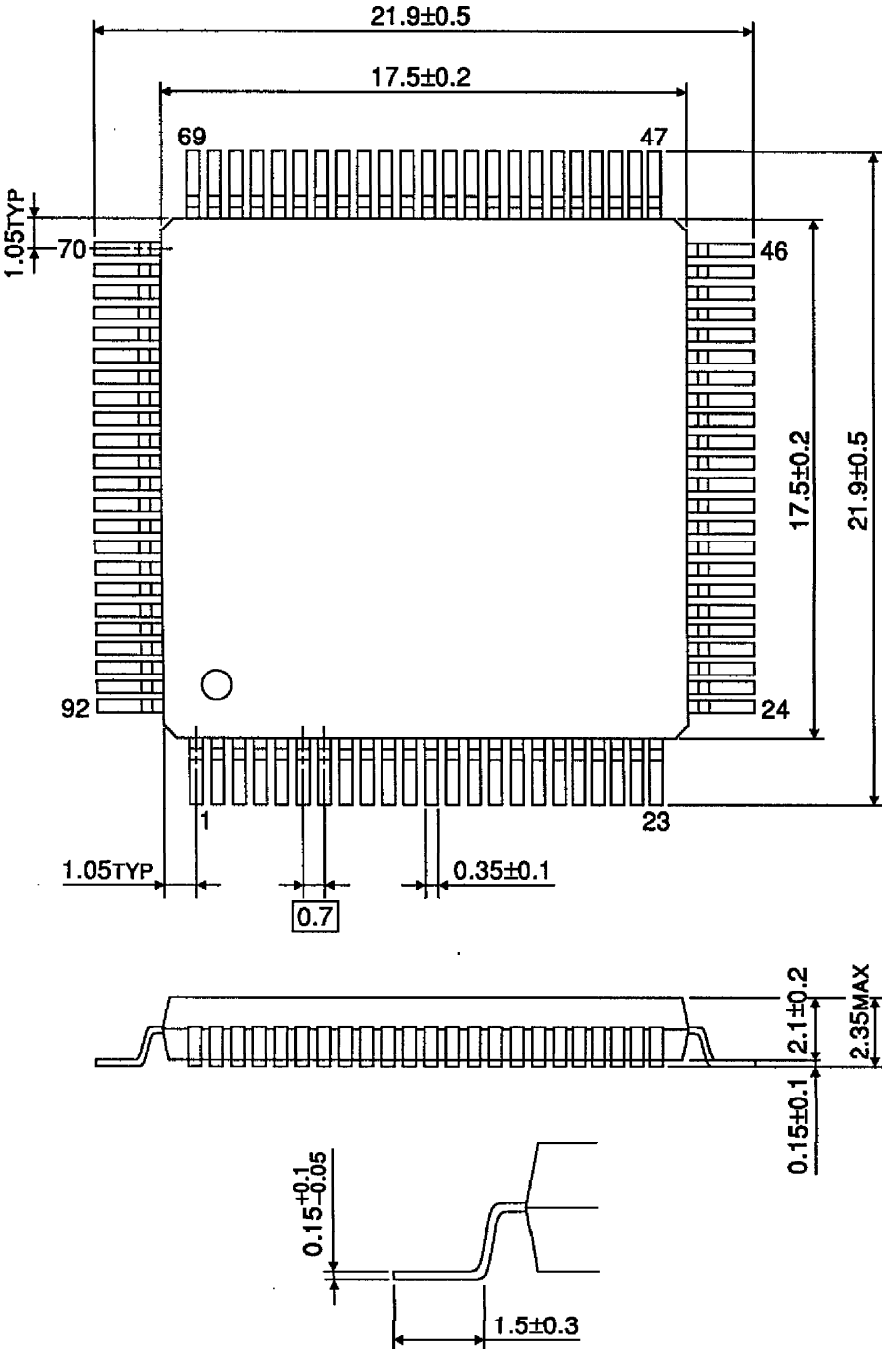

Weight : 1.4g (Typ.)