

Data Sheet
April 1997

microelectronics group

Lucent Technologies
Bell Labs Innovations



T7121 HDLC Interface for ISDN (HIFI-64)

Features

- Low-cost device for B-channel (64 kbits/s) or D-channel (16 kbits/s) data transport.
- Optional transparent mode—no HDLC framing is performed.
- Frame sync (FS) allows a slot-select feature to access an individual time slot in any TDM data stream (e.g., Lucent Technologies Microelectronics Group Concentration Highway Interface [CHI] or subset).
- Bit-masking option allows effective data rates of 8, 16, 24, 32, 40, 48, and 56 kbits/s.
- Maximum data rate up to 4.096 MHz.
- Serial data-transfer pins for direct connection to the Lucent ISDN line transceiver T7250C.
- Supports IOM2, K2, GCI, and SLD interface.
- Parallel microprocessor interface with either multiplexed or demultiplexed address and data lines for easy interface with any microprocessor.
- Single interrupt output signal with seven maskable interrupt conditions.
- Programmable interrupt modes.
- Memory-mapped read and write registers.
- TTL/CMOS compatible input/output.
- 3-state output pins to assist system diagnostics.
- Low-power 1.25 μm CMOS:
 - 30 mW typical operation at 12 MHz.
 - 5 mW standby mode (typical).
- HDLC transceiver:
 - Stand-alone HDLC framing operation.
 - 64-byte FIFO in both transmit and receive directions.
 - Supports block-move instruction.
 - Multiple frames allowed in FIFO.
 - Programmable FIFO full- and empty-level interrupt.

Description

The T7121 HDLC Interface for ISDN (HIFI-64) connects serial communications links carrying HDLC bit-synchronous data frames to 8-bit microcomputer systems. There is an optional transparent mode of operation in which no HDLC processing is performed on user data. The device communicates with the system microprocessor as a memory-mapped peripheral and is controlled by reading and writing 19 internal registers. The chip can be instructed to interrupt the microprocessor when it detects certain events requiring microprocessor attention. The HDLC transmitter and receiver are each buffered with 64-byte, first-in-first-out (FIFO) memory storage. The 64-byte buffer depth reduces the number of status polls or interrupts to be processed by the microprocessor, improving overall system efficiency. The major blocks are the microprocessor interface, transmit and receive FIFO memory buffers, HDLC processor, and a concentration highway interface (see Figure 1). The T7121 device is available in a 28-pin, plastic DIP or a 28-pin, plastic, small-outline, J-lead (SOJ) package for surface mounting.

Table of Contents

| Contents | Page |
|---|------|
| Features | 1 |
| Description..... | 1 |
| Pin Information | 4 |
| Functional Description | 8 |
| Microprocessor Bus Interface | 8 |
| Addressing | 8 |
| Interrupts | 8 |
| Resets | 9 |
| FIFO Memory Buffers | 9 |
| Transmit FIFO | 9 |
| Receive FIFO | 10 |
| Block Move..... | 10 |
| Serial Link Interface | 10 |
| Enabling the Transmitter and Receiver..... | 10 |
| Time-Slot Feature | 13 |
| Transmission During Unassigned Time Slots | 14 |
| Bit Order During Transmission..... | 14 |
| Bit Masking..... | 16 |
| SLD and IOM2 Examples..... | 19 |
| HDLC Operation | 19 |
| Zero-Bit Insertion/Deletion (Bit Stuffing/Destuffing) | 19 |
| Transmitter FIFO..... | 21 |
| Sending 1-Byte Frames | 21 |
| Transmitter Underrun | 21 |
| Using the Transmitter Status and Fill Level | 21 |
| Receiver FIFO..... | 21 |
| Receiver Overrun | 23 |
| Operational Note (T7121-EL, T7121-PL, T7121-EL2, and T7121-PL2) | 23 |
| Transparent Mode..... | 24 |
| Diagnostic Modes | 25 |
| Loopbacks..... | 25 |
| 3-State Mode..... | 28 |
| Other | 28 |
| Powerdown Mode | 28 |
| Registers..... | 28 |
| Absolute Maximum Ratings..... | 45 |
| Electrical Characteristics | 45 |
| Clock Characteristics..... | 46 |
| Timing Characteristics | 46 |
| TDM Frame Timing Diagrams..... | 46 |
| Multiplexed Address and Data | 51 |
| Separate Address and Data..... | 53 |
| Concentration Highway..... | 55 |
| Handling Precautions | 59 |
| Outline Diagrams..... | 60 |
| 28-Pin, Plastic DIP | 60 |
| 28-Pin, Plastic SOJ, Surface Mounting..... | 61 |
| Ordering Information..... | 62 |
| Appendix..... | 63 |
| Transparent Mode..... | 63 |
| HDLC Mode | 63 |
| General Features | 64 |
| Power and Ground..... | 66 |

Description (continued)

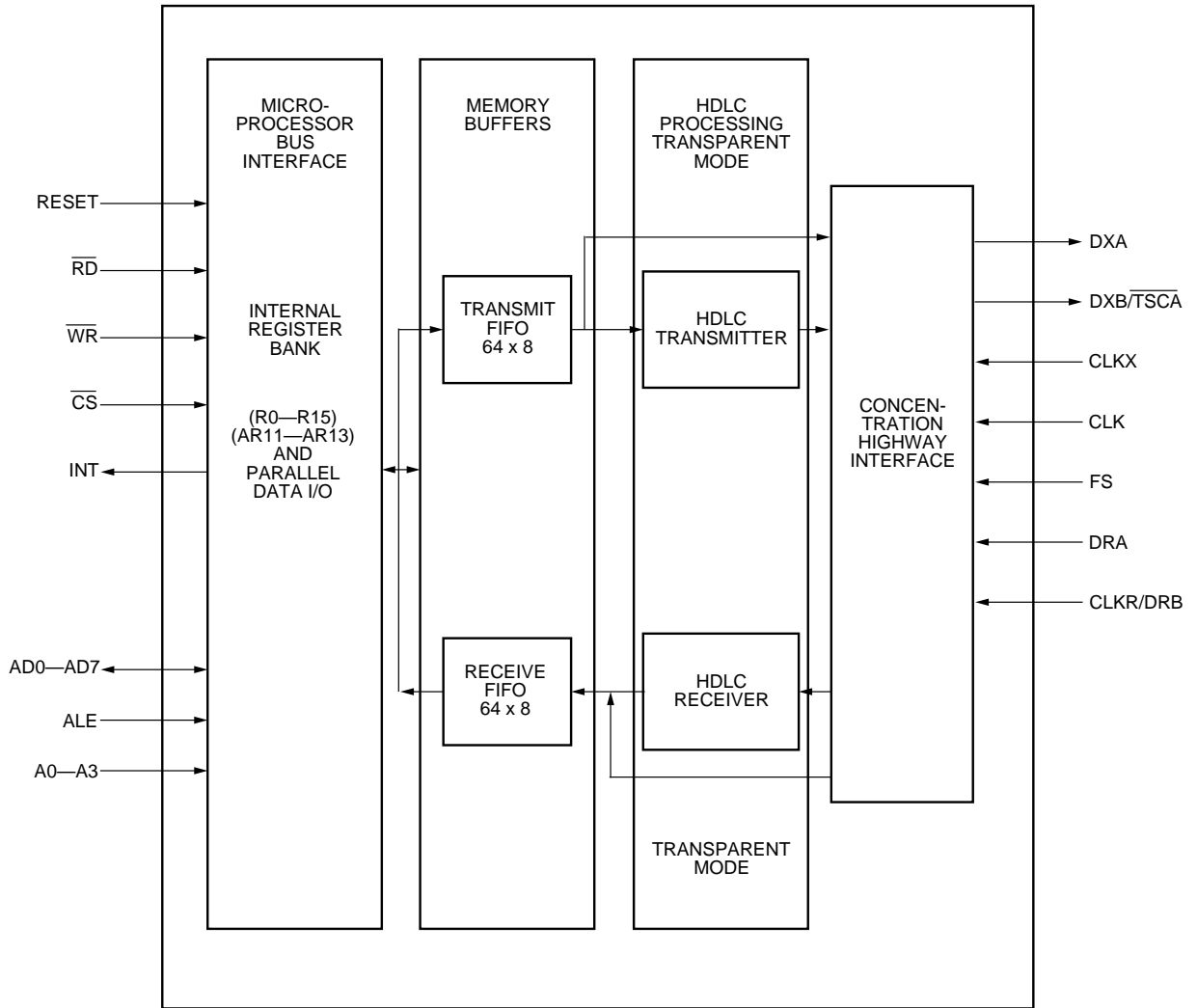

5-5027

Figure 1. Block Diagram

Pin Information

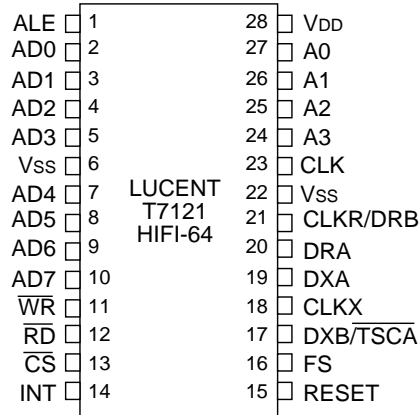

5-5028

Figure 2. Pin Diagram

Table 1. Pin Assignments

| Group | Symbol | Function |
|------------------------------|---|---|
| Chip Clock | CLK | 0 MHz—12 MHz |
| Power & Ground | V _{DD} V _{SS} | 5 V Power Ground |
| Microprocessor Bus Interface | RD WR CS INT RESET AD7—AD0 ALE A3—A0 | Read Write Chip Select Interrupt Reset Address/Data Bus Address Latch Enable Address Bus (non-ALE addressing mode) |
| Serial Link Interface | DXA DXB TSCA CLKX FS CLKR DRA DRB | Transmit Data A Transmit Data B Time-slot Control DXA Transmit Clock Frame Synchronization Receive Clock Receive Data A Receive Data B |

Pin Information (continued)

Table 2. Pin Descriptions

| Pin | Symbol | Type | Name/Function |
|--------------|-----------------|------|--|
| 1 | ALE | I | Address Latch Enable. A high-to-low transition on this pin latches the register address on pins AD3—AD0. ALE should be held high in the demultiplexed (separate address/data) mode. ALE latches the address regardless of the state of \overline{CS} . |
| 2—5, 7—10 | AD0—AD7 | I/O | Address/Data Bus. The data bus direction is controlled by the logic states of the \overline{CS} , \overline{RD} , and \overline{WR} pins. Microprocessors using a multiplexed bus supply address information during read or write cycles on AD6, AD3—AD0 synchronized to the ALE signal. During read cycles, data is available to the microprocessor on AD7—AD0. During write cycles, data is supplied by the microprocessor on these lines. When \overline{CS} is not active, the AD7—AD0 pins are placed in a high-impedance state (3-state). AD0 is the least significant address/data bit. Block move is available in MUXed address and data mode by setting the BM bit in register 0 (R0—B3) to 1 and holding AD6 high during the address cycle of the ALE. All writes then go directly to the transmit FIFO, and all reads address the receive FIFO. Normal ALE mode addressing is accomplished by holding AD6 low during the ALE address cycle. Block move can be disabled by clearing the BM bit to 0. |
| 6, 22 | Vss | — | Ground. |
| 11 | \overline{WR} | I | Write (Active-Low). This signal controls when data is written to the registers. When \overline{CS} and \overline{WR} are low, valid data is supplied on lines AD7—AD0 by the microprocessor. The chip latches the data on the rising edge of \overline{WR} . |
| 12 | \overline{RD} | I | Read (Active-Low). This signal is used to read data from the registers. When \overline{CS} and \overline{WR} are low, the chip makes the requested data available on lines AD7—AD0 to be read by the microprocessor. |
| 13 | \overline{CS} | I | Chip Select (Active-Low). This signal must be low for the internal registers to be read or written. |
| 14 | INT | O | Interrupt. An interrupt signal is generated when any of the interrupting conditions are true. The interrupt signal remains active until the microprocessor reads the interrupt status register (R15) if DINT (R0—B0) = 0, or until the condition causing the interrupt is alleviated if DINT = 1. Interrupts can be masked by appropriately setting the corresponding interrupt enable bits in the interrupt mask register (R14). The polarity of the interrupt signal output is controlled by the IPOL bit in register 0 (R0—B1). This pin is not an open-drain output. |
| 15 | RESET | I | Reset. A high on this pin resets the device and forces a high-impedance (3-state) condition on all outputs. All register bits are forced to their reset values. (See Register section for more details.) A reset must be performed upon power-up. A full chip reset occurs with or without a clock input. |
| 16 | FS | I | Frame Synchronization. This signal marks the beginning of a TDM highway frame. The polarity of the input pulse can be adjusted via the FSPOL bit in register 0 (R0—B6). Individual time slots are assigned relative to the detection of FS by the use of registers 7—11. When HWYEN (R0—B7) is 0, the input to this pin is ignored. |

Pin Information (continued)

Table 2. Pin Descriptions (continued)

| Pin | Symbol | Type | Name/Function |
|-----|------------------------|------|---|
| 17 | DXB/ \overline{TSCA} | O | <p>Transmit Data B or Time-Slot Control for DXA. The functionality of this pin is user-controlled by the P17CTL bit in the receiver control register (R5—B7). Clearing the P17CTL bit to 0 selects operation as Transmit Data B. Once DXB operation is selected, data is transmitted on DXB whenever the DXBC bit in register 7 (R7—B6) is set to 1. Data can be configured for transmission on either CLKX edge (CLKXI, R9—B4), optionally inverted (DXI, R10—B7) and placed in a user-selected time slot (registers 7, 9, 10) with bit 0 or bit 7 sent first (TLBIT, R10—B6).</p> <p>DXB should be pulled up by an external resistor to prevent random data patterns from propagating through other devices when DXB is 3-stated.</p> <p>When P17CTL (R5—B7) is set to 1, this pin is configured as \overline{TSCA} (active-low) (time-slot control for DXA). \overline{TSCA} allows use of an external 3-stating bus driver when data is being transmitted on DXA over long distances. \overline{TSCA} goes low during the valid bit positions of data and is high at all other times.</p> <p>When an external driver is required, DXAC (R7—B7) must be set to 1. Setting the P17CTL bit (R5—B7) to 1 overrides the selection of DXBC (R7—B6).</p> |
| 18 | CLKX | I | <p>Transmit Clock. This input clock controls the bit rate for transmitted data. Transmit clock frequency must be less than the chip master clock frequency divided by 2 ($f_{CLKX} < f_{CLK}/2$). In the reset configuration, data is transmitted on the falling edge of CLKX. Data can be transmitted by using the rising edge of CLKX by setting the CLKX Invert bit (CLKXI) in the bit offset register (R9—B4) to 1. If the P21CTL bit in the receiver control register (R5—B6) is set to 1, this clock is also used to receive data. If P21CTL is 0, the transmit clock rate can be independent of the receive clock rate.</p> |
| 19 | DXA | O | <p>Transmit Data A. When the DXAC bit in register 7 (R7—B7) is set to 1, data is transmitted on this pin. If external drivers are not required, both DXAC (R7—B7) and DXBC (R7—B6) can be set to allow simultaneous transmission of the data byte on both transmit data pins.</p> <p>Data can be configured for transmission on either CLKX edge (CLKXI, R9—B4), optionally inverted (DXI, R10—B7) and placed in a user-selected time slot (registers 7, 9, 10) with bit 0 or bit 7 sent first (TLBIT, R10—B6).</p> <p>DXA should be pulled up by an external resistor to prevent random data patterns from propagating through other devices when DXA is 3-stated.</p> |
| 20 | DRA | I | <p>Receive Data A. When the DRA/B bit in register 8 (R8—B7) is cleared to 0, data is received on this pin. Data can be optionally inverted (DRI, R11—B7), received on a positive or negative receive clock edge (CLKRI, R9—B0), and received during a user-selected time slot (registers 8, 9, 11) with bit 0 or bit 7 first (RLBIT, R11—B6).</p> |

Pin Information (continued)

Table 2. Pin Descriptions (continued)

| Pin | Symbol | Type | Name/Function |
|-------------------|----------|------|---|
| 21 | CLKR/DRB | I | <p>Receive Clock or Receive Data B. The functionality of this pin is controlled by programming the P21CTL bit in the receiver control register (R5—B6). When P21CTL is cleared to 0 (default), this pin is the receive data clock (CLKR). Receive clock frequency must be less than the chip master clock frequency divided by 2 ($f_{CLKR} < f_{CLK}/2$). Upon reset, data is received (latched) on the rising edge of CLKR. Data can be received on the falling edge of the receive clock by clearing the CLKRI bit in register 9 (R9—B0) to 0. Receive clock rate can be independent of transmit clock rate.</p> <p>When P21CTL (R5—B6) is set to 1, this pin is configured as Receive Data B (DRB). Clocking for receive data is obtained from CLKX, while CLKRI (R9—B0) controls the edge of CLKX used to latch received data. In this mode, data can be received on DRA or on DRB. DRB is selected by setting the DRA/B bit in register 8 (R8—B7) to 1. Data can be optionally inverted (DRI, R11—B7) and received during a user-selected time slot (registers 8, 9, 11) with bit 0 or bit 7 first (RLBIT R11—B6).</p> |
| 23 | CLK | I | <p>Clock. This clock controls internal chip operation. It can be from 0 MHz to 12 MHz. Typically it is 6.144 MHz (i.e., SYSCO from the Lucent T7250C). Clock frequency must be greater than two times the fastest data clock frequency.</p> |
| 24, 25, 26, 27 | A3—A0 | I | <p>Address Bus. These four address leads allow the chip to be accessed by a microprocessor employing separate address and data leads. They are used to select the internal registers. The ALE pin should be tied high in this mode of operation.</p> <p>These pins can be left unconnected when in the multiplexed address/data mode (internal pull-up resistors are provided).</p> |
| 28 | VDD | — | +5 V Supply. |

T7121 HDLC Interface for ISDN (HIFI-64)

Functional Description

Microprocessor Bus Interface

Addressing

The T7121 is designed to easily interface with 8-bit microprocessors. The microprocessor bus interface allows parallel asynchronous access to a bank of 19 registers (R0—R15 and AR11—AR13). The bus interface is compatible with most microprocessors. The registers occupy 16 continuous locations in the memory map of a controlling microprocessor, and the registers are accessed under the control of the following signals: address select (A0—A3 or AD0—AD7), address latch enable (ALE), chip select (CS), read (RD), and write (WR). When multiplexed address and data lines are used, the ALE signal is used to latch the address present on AD0—AD3 and AD6. AD6 has a special use in the block-move mode. See the Block Move section under the FIFO Memory Buffers section. ALE should be tied high when separate address and data are used.

Registers 11, 12, and 13 have alternate meanings depending on the value of the Alternate (ALT) bit in the chip configuration register (R0—B4). The alternate registers are accessed by setting the ALT bit (R0—B4) to 1. All subsequent addressing of registers 11 through 13 then refers to the alternate registers (AR11—AR13). Returning to the foreground register set is accomplished by clearing the ALT bit (R0—B4) to 0.

Interrupts

A programmable interrupt output, INT, is provided to alert the microprocessor when the device needs service. Associated with the interrupt system are the IPOL bit in register 0 (R0—B1), the interrupt mask register (R14), and the interrupt status register (R15). The polarity of the INT signal (pin 14) is programmable by setting the IPOL bit in register 0 (R0—B1). The interrupt mask register can be programmed so that only certain conditions cause the INT signal to be asserted. The interrupt status register (R15) reveals the source of the interrupt.

Register 14, the interrupt mask register, controls the operation of the INT pin. Masking an interrupt means that no transition of the INT pin is generated for any occurrence of that interrupt condition. The INT signal is enabled upon the first occurrence of any unmasked interrupt condition. The INT signal remains until the interrupt is acknowledged by reading the interrupt status register (R15). Unmasked interrupts occurring between the first unmasked interrupt and the status register read do not cause a transition of the INT pin. If

a second interrupt occurs during a read of the interrupt status register (R15), the INT signal is disabled after the read and then reasserts itself. This deassertion can actually be much less than one cycle, and no minimum width is guaranteed. One method to ensure that the second interrupt is detected is to use an edge-sensed INT pin on the processor. If this is not available, the interrupt service routine should reread the interrupt status register to determine if an interrupt occurred during the clearing of the first interrupt.

Masking all interrupts effectively disables the INT pin. It is possible to mask a currently active interrupt. Doing so causes a transition of the INT pin from active to inactive if the masked interrupt was the only active interrupt. Likewise, unmasking an interrupt that is currently asserted causes an INT pin transition from inactive to active if all other unmasked interrupts were currently inactive. Interruptable conditions are always reported in register 15, even if the interrupt pin transition is masked. Thus, polled interrupt systems are also supported. Note that a transition of the INT pin occurs only if the interrupting condition is unmasked and no other unmasked, unacknowledged interrupt exists.

The HIFI-64 allows two modes of interrupt: dynamic and nondynamic. The mode is controlled by setting the DINT (Dynamic INTerrupt) bit in register 0 (R0—B0). If DINT (R0—B0) is 0 (nondynamic mode), the interrupt bits in the interrupt status register (R15) are cleared directly by a read of register 15. The condition causing the interrupt must go away and come back in order to reassert the interrupt. If DINT (R0—B0) is set to 1 (dynamic mode), the transmitter empty (R15—B1) and receiver full (R15—B3) interrupts are cleared only when the condition causing the interrupt has been remedied (all other interrupts are cleared by reading the interrupt status register [R15]). In addition, the INT signal (pin 14) remains enabled until the condition(s) causing the interrupt has been remedied.

A dynamic version of the transmitter empty interrupt, transmitter empty dynamic (TED), is provided in the transmitter status register (R2—B7). TED behaves dynamically regardless of the value of the DINT bit (R0—B0). TED does not cause a transition of the INT pin.

In transparent mode, the REOF, RIDL, and UNDA BT interrupts are disabled. TDONE is used to indicate a transmitter underrun and can be used to determine transmission end. Additionally, the MSTAT bit (AR11—B3) can be used as a polled interrupt to determine the beginning of receive data. A transition of the INT pin can be programmed for the beginning of receive data by setting the initial receiver-full interrupt level RIL (R5—B[5—0]) to 1 byte.

Functional Description (continued)

Resets

The T7121 is fully reset by either asserting the RESET pin (hardware reset) or by asserting both the TRES (R6—B5) and RRES (R6—B4) bits simultaneously when writing to register 6 (software reset). A full reset results in all registers returning to their default conditions and all logic returning to a known state. No clock input is necessary. During a hardware reset, all outputs are 3-stated. Thus, the RESET pin can be used for bed-of-nails testing. During a software reset, outputs are not automatically 3-stated. Output pin states are determined by their default register configuration. Both transmit data pins (DXA and DXB) 3-state since the default register configuration is both transmit pins disabled. The INT pin is high.

In addition, the transmitter and receiver can be individually reset. When TRES (R6—B5) is high and RRES (R6—B4) is low during a write of register 6, the transmitter is independently reset. The transmitter FIFO pointers return to default values, resulting in the loss of any untransmitted data, and the transmitter state machine is returned to the idle state. Transmitter interrupts are cleared, except for the TE (R15—B1) interrupt, which is asserted and causes a transition on the INT pin if unmasked (TEIE, R14—B1 = 1). Only transmit status registers and interrupts change to reflect the reset. Disabling the transmitter does not cause an automatic reset. When the transmitter has been active and then subsequently disabled, a TRES is needed to restore it to a known state.

When TRES (R6—B5) is low and RRES (R6—B4) is high during a write of register 6, the receiver is independently reset. A receiver reset causes the receiver FIFO pointers to return to their default values, resulting in the loss of unread data in the FIFO. The receiver is returned to a known state, and all currently asserted receiver interrupts are cleared. The receiver should be reset whenever it was active and subsequently disabled to ensure correct operation. Only receiver status and interrupt bits are affected in the register set. Disabling the receiver does not cause a receiver reset.

FIFO Memory Buffers

The HIFI-64 is equipped with a transmit FIFO and a receive FIFO, each with a capacity of 64 bytes.

Transmit FIFO

Data to be transmitted is loaded via the data register (R3) into the 64-byte transmit FIFO. Multiple frames can be placed in the FIFO. In HDLC mode, the final byte of each frame is marked by writing the transmit frame complete bit TFC (R1—B7). The transmitter can also be instructed to abort a frame by using the transmit abort bit TABT (R1—B6) (HDLC mode only). Transmission status is available in the transmit status register and via the transmit interrupts. The transmitter status register (R2) indicates how many additional bytes can be added to the FIFO. The transmitter interrupt trigger level (TIL) can be programmed in the transmitter control register (R1—B[5—0]) to tailor service time intervals to the system environment. The transmit empty (TE) interrupt bit is set in the interrupt status register (R15—B1) when the FIFO has sufficient empty space to add the number of bytes specified in the TIL. If the TE interrupt mask TEIE (R14—B1) is 1, the occurrence of a TE interrupt condition causes a transition of the interrupt pin if no other unmasked interrupts are currently active. In dynamic interrupt mode (DINT, R0—B0 = 1), this interrupt remains set until the condition is cleared. In nondynamic interrupt mode (DINT, R0—B0 = 0), this interrupt is cleared by reading R15. A TDONE (R15—B0) interrupt occurs for each HDLC frame completed. In the transparent mode, a TDONE interrupt occurs when the transmit FIFO empties. In HDLC mode, an UNDABT (R15—B2) interrupt is issued if the transmitter underruns.

There is no interrupt indication of a transmitter overrun that is writing more data than empty spaces exist. Overrunning the transmitter causes the last valid data byte written to be repeatedly overwritten, resulting in missing data in the frame.

T7121 HDLC Interface for ISDN (HIFI-64)

Functional Description (continued)**Receive FIFO**

Data received from the serial link interface is stored in the 64-byte receive FIFO. In the HDLC mode, the receiver also places a status of frame (SF) status byte in the receiver FIFO for every completed frame received. Whenever an SF frame status byte is present in the receive FIFO, the EOF bit (R4—B7) is set. The receiver queue status (RQS) bits (R4—B[6—0]) report the number of bytes up to and including the first SF frame status byte. If no SF frame status byte is present in the FIFO (EOF, R4—B7 = 0), the count directly reflects the number of data bytes available to be read.

Depending on frame size, it is possible for multiple frames to be present in the FIFO. The receiver fill level indicator (RIL) can be programmed in the receiver control register (R5—B[5—0]) to tailor the service time interval to the system environment. The receiver full (RF) interrupt bit is set in the interrupt status register (R15—B3) when the FIFO reaches the preprogrammed full position. The RF interrupt condition is reported in the interrupt register (R15—B3). If the RF interrupt mask RFIE (R14—B3) is 1, the occurrence of an RF interrupt condition causes a transition of the interrupt pin if no other unmasked interrupts are present. In dynamic interrupt mode (DINT, R0—B0 = 1), this interrupt remains set until the condition is cleared. In nondynamic interrupt mode (DINT, R0—B0 = 0), this interrupt is cleared by reading R15. In the HDLC mode, an REOF interrupt is issued when the receiver has identified the end of a frame and written the SF status byte for that frame. An overrun interrupt is generated when the receiver needs to write either status or data to the FIFO and finds the FIFO full. An overrun condition causes the last byte of the FIFO to be overwritten with an SF status byte indicating the overrun status. In the HDLC mode, an RIDL interrupt is issued whenever 15 or more continuous 1s have been received.

Block Move

The block-move mode is intended to support microprocessors with a memory-to-memory move instruction. Memory-to-memory move instructions can be faster and reduce the amount of code needed to service the FIFOs. Block-move mode allows the T7121 FIFOs to appear as a block of memory. Systems using block move need to allocate 16 addresses to the T7121 register set (with AD6 = 0) and 64 addresses to the FIFOs (with AD6 = 1). Block move is **available only in the MUXed address and data mode** by setting the BM bit in register 0 (R0—B3) to 1.

When block move is enabled (BM, R0—B3 = 1) and AD6 is held high during the address cycle of the ALE, the address is translated internally to R3, the data byte register. All writes then go directly to the transmit FIFO, and all reads address the receive FIFO. Normal register addressing is accomplished by holding AD6 low during the ALE address cycle. Block moves can be disabled by clearing the BM bit (R0—B3) to 0.

Serial Link Interface

The HIFI-64 can interface to a wide variety of serial links. In the simplest interface, the time-slot feature is not used, and the HIFI-64 performs HDLC processing in conjunction with three externally supplied clocks: CLK, CLKR, and CLKX. The maximum data rate frequency is 4.096 MHz, and the minimum CLK frequency must be greater than two times the fastest data clock frequency. In the case of a burst clock, the fastest data clock frequency is defined as the clock frequency during the burst.

If the time-slot feature is enabled (HWYEN, R0—B7 = 1), the HIFI-64 is capable of controlling separate transmit and receive time slots on a wide variety of time-division multiplexed (TDM) serial highways. In particular, the HIFI-64 can interface to the Lucent Concentration Highway—a variable-speed, dual full-duplex serial highway. The HIFI-64 can also interface to a variety of TDM highways containing 64 or fewer time slots (primary-rate interface, SLD, K, K2, GCI, IOM, IOM2, etc.).

The IOM, IOM2, and GCI interfaces specify the data clock to be twice the data transmission frequency. In order to comply with this specification, a Clock Mode Select (CMS) bit (R8—B6) has been included. The bit has the effect of dividing the data clock by two internally. In CMS mode, the minimum CLK frequency must be greater than the data clock.

Enabling the Transmitter and Receiver

The HIFI-64 can transmit on either of two transmit data pins (DXA, pin 19, and DXB, pin 17), or can broadcast on both pins by appropriately programming the DXAC (R7—B7) and DXBC (R7—B6) bits in the transmit time-slot control register (R7—B6,B7). If both pins are selected, the same data appears on both. The behavior of pin 17, either DXB or \overline{TSCA} , is controlled by the P17CTL (R5—B7) bit. The P17CTL bit must be cleared to 0 to enable transmission on DXB. Pin 17 can be configured as \overline{TSCA} by setting P17CTL to 1. When P17CTL is set to 1, the setting of DXBC (R7—B6) is ignored. While configured as \overline{TSCA} , pin 17 is low continually if HWYEN (R0—B7) = 0 and DXAC (R7—B7) = 1.

Functional Description (continued)

When HWYEN = 1 and DXAC = 1, pin 17 \overline{TSCA} is low during unmasked bits of the selected time slot. Otherwise \overline{TSCA} is high.

The transmitter begins transmission when the transmitter enable ENT bit (R6—B3) is set to 1. Once the ENT bit is enabled, user data is transmitted on the selected transmit data pin(s) (DXA, DXB, both, or neither). If the transmitter is enabled and no transmit data pin has been selected, the HIFI-64 3-states both pins and the FIFO empties as if the data were being transmitted. When the transmitter is disabled (ENT = 0), the transmitter continuously transmits 1s on the selected transmit data pin(s) (DXA, DXB, or both). If neither DXA nor DXB is selected, both pins are 3-stated. The microprocessor can load the FIFO as normal while the transmitter is disabled. Disabling the transmitter does not cause a transmitter reset. When the transmitter is disabled after having been enabled, the transmitter should be reset via a TRES (R6—B5) = 1. Table 3 summarizes the transmit pin behavior based on the four register bits that can affect it. This table assumes that P17CTL is set to 0 and that, in TDM highway modes, at least one data bit is unmasked.

Table 3. Transmit Pin Behavior

| HWYEN (R0—B7) | ENT (R6—B3) | DXAC (R7—B7) | DXBC* (R7—B6) | DXA (Pin 19) | DXB (Pin 17) | Comments |
|------------------|----------------|-----------------|------------------|-----------------|-----------------|--|
| 0 | 0 | X | X | 3-state | 3-state | Reset condition. |
| 0 | 1 | 0 | 0 | 3-state | 3-state | Data can be lost. |
| 0 | 1 | 0 | 1 | 3-state | user data | — |
| 0 | 1 | 1 | 0 | user data | 3-state | — |
| 0 | 1 | 1 | 1 | user data | user data | — |
| 1 | 0 | 0 | 0 | 3-state | 3-state | Concentration highway interface enabled. |
| 1 | 0 | 0 | 1 | 3-state | 1s | Transmit 1s during user-programmed time slot until transmitter is enabled. |
| 1 | 0 | 1 | 0 | 1s | 3-state | |
| 1 | 0 | 1 | 1 | 1s | 1s | |
| 1 | 1 | 0 | 0 | 3-state | 3-state | Data can be lost. |
| 1 | 1 | 0 | 1 | 3-state | user data | — |
| 1 | 1 | 1 | 0 | user data | 3-state | — |
| 1 | 1 | 1 | 1 | user data | user data | — |

* P17CTL = 0 is assumed.

The edge of CLKX (pin 18) used for data transmission is programmable by using CLKXI (R9—B4). Setting CLKXI to 1 causes the T7121 to transmit data using the positive edge, while setting CLKXI to 0 enables transmission on the negative edge (DEFAULT). Whenever the clock edge is changed, the transmitter should be reset via TRES (R6—B5). When a gated clock is used to begin transmission on the first programmed clock edge, the opposite clock edge must be provided first, after the reset. For example, if a gated clock with a negative edge transmission is used, a positive edge of the clock should be provided first. This extra edge is only necessary on initial enabling of the transmitter.

Functional Description (continued)

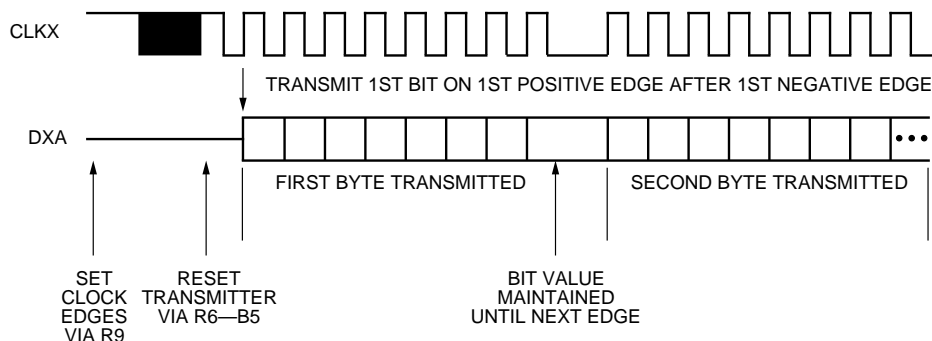

5-5029

Figure 3. Transmitting with a Gated Clock

The receiver can be enabled or disabled by programming the ENR bit (R6—B2). When disabled, the receiver ignores all serial inputs (i.e., no data loaded into the FIFO). Whatever was in the FIFO before the receiver was disabled remains intact, and the microprocessor can read the contents as normal. Disabling the receiver does **not** cause a receiver reset. Whenever the receiver has been enabled and is subsequently disabled, the receiver must be reset via RRES (R6—B4) before it is reenabled.

The HIFI-64 can receive data on either of two receive data pins (DRA, pin 20, or DRB, pin 21) depending on the programming of the DRA/B bit in register 8 (R8—B7). The HIFI-64 can be programmed to use either the input of pin 21 (CLKR/DRB) or the input of pin 18 (CLKX) as the receive clock using P21CTL (R5—B6). Clearing P21CTL to 0 (DEFAULT) selects pin 21, while a setting of 1 selects pin 18. The selected clock can be programmed to latch received data on either clock edge using CLKRI (R9—B0). Setting CLKRI to 1 causes the receiver to use the positive receive clock edge to latch data, while clearing CLKRI to 0 causes the receiver to use the negative edge. Whenever the clock edge is changed, the receiver should be reset via an RRES (R6—B4). When a gated clock is used, the receiver begins latching data on the first programmed clock edge. When a gated clock is used, separate transmit and receive clocks must be used if data alignment to the first clock edge is required, since the transmit clock requires an extra edge to align. See Figures 3 and 4.

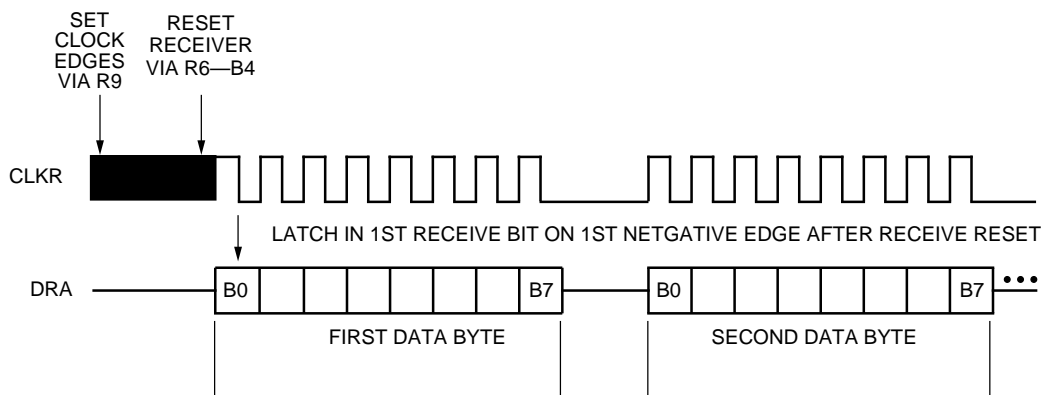

5-5030

Figure 4. Receiving with a Burst Clock

Functional Description (continued)

Time-Slot Feature

The HIFI-64 can be configured to interface with devices supplying a frame-synchronization signal (FS) to indicate the beginning of a single or multiple time-slot sequence. The T7121 can be configured to interface to TDM highways from 3 to 64 time slots.

The HWYEN bit (R0—B7) enables the time-slot feature logic. All highway parameters should be programmed before enabling HWYEN. When HWYEN is 0, any input on the FS pin is ignored. When HWYEN is 1, data transmission begins with the first programmed time slot following the first detected frame sync, provided that at least one of the transmit pins is enabled and at least one transmit bit is unmasked. The first data byte transmitted in all cases is FF hex. When transmit highway parameters are changed, such as time slot, the transmitter and transmit output pins should be disabled (ENT R6—B3 = 0, DXBC R7—B6 = 0, DXAC R7—B7 = 0). This guarantees that no other time slot is corrupted during reprogramming. When the receiver time slot is changed, the receiver should be disabled (ENR R6—B2 = 0). After reprogramming, 1 TDM frame is necessary to resynchronize. When HWYEN is first enabled, the user should wait one TDM frame between enabling HWYEN and enabling the transmit outputs. The highway logic is reset completely to a known state by each FS pulse or by a full chip reset.

The T7121 provides a bit masking feature to allow sub-rate operation. The default bit masks are FF hexadecimal for the receiver bit mask (R12) and 00 hexadecimal for the transmitter bit mask (R13). The transmitter by default transmits no bits in the selected time slot. To enable transmission of all 8 bits in the selected time slot, the transmitter bit mask (R13) must be changed to FF hexadecimal (see the Bit Masking section for more details).

The HIFI-64 determines that an FS has occurred by sampling the FS signal with the appropriate data clock. The polarity of a valid FS is determined by FSPOL (R0—B6). That is, if FSPOL is 0, the FS is considered valid when low. When FSPOL is 1, the FS is considered valid when high. When an FS pulse is provided, at least one FS pulse must be provided for every 512 data clock cycles. The FE bit (R0—B5) controls the edge of the data clock used to sample the FS signal. If FE (R0—B5) is cleared to 0, FS is sampled on a negative edge of the transmit and receive data clocks. If FE is set to 1, FS is sampled on a rising edge of the transmit and receive data clocks.

The HIFI-64 can be programmed to transmit data on either a positive or negative edge of the data clock by programming the CLKXI bit (R9—B4). Similarly, the device can be programmed to sample received data on either a positive or negative edge of the data clock by programming the CLKRI bit (R9—B0). The timing of the transmission or reception of the first bit relative to the frame-sync pulse then depends on the configuration of three bits: FE (R0—B5), CLKXI (R9—B4), and CLKRI (R9—B0). Figure 12 in the Timing Characteristics section shows the position of the first transmit bit and receive bit relative to the FS for each combination of these register bits. These register configurations are assumed:

| | | |
|-----------------------|---|--------|
| HWYEN (R0—B7) | = | 1 |
| FSPOL (R0—B6) | = | 1 |
| TBOF[2—0] (R9—B[7—5]) | = | 000 |
| RBOF[2—0] (R9—B[3—1]) | = | 000 |
| TSLT[5—0] (R7—B[5—0]) | = | 000000 |
| RSLT[5—0] (R8—B[5—0]) | = | 000000 |

Figure 13 in the Timing Characteristics section shows an example of bit masking; all other examples assume no masking. Transmission can be over DXA and/or DXB (depending on the configuration of the DXAC and DXBC bits in register 7 [R7—B6,7]), and TSCA is shown to illustrate transmission over DXA with an external driver. DRA or DRB can be used to receive incoming data (depending on configuration of the DRA/B bit [R8—B7]).

The HIFI-64 can be programmed to delay transmission of the first bit by using the offset registers. These are the transmit bit offset TBOF (R9—B[7—5]), the transmit time-slot TSLT (R7—B[5—0]), and the transmitter time-slot offset TTISO (R10—B[5—0]). The transmit bit offset register moves the transmission of the first bit forward one bit at a time, up to 7 bits total. The transmitter time-slot offset moves the first bit forward by multiples of 8 bits. The combination of the settings of these two registers defines the position of time slot 0. From that point, the time slot is selected by the value of the transmitter time slot TSLT (R7—B[5—0]). The first bit is transmitted

$$TBOF + (8 \times TTISO) + (8 \times TSLT) = N$$

bit times after the beginning of the TDM frame.

Functional Description (continued)

Similarly for the receiver, the receive bit offset RBOF (R9—B[3—1]) and the receive time-slot offset RTSOF (R11—B[5—0]) determine where the first bit of the first receive time slot is found. The time slot used is selected by the value of the receiver time-slot RSLT (R8—B[5—0]). The first bit is received

$$RBOF + (8 \times RTSOF) + (8 \times RSLT) = M$$

bit times after the beginning of the TDM frame. Figure 5 illustrates using the offsets to configure a system consisting of four time slots, where the initial time slot aligns with the FS. For this system, FE = 0, CLKXI = 1, CLKRI = 0, TSLT = 000000, and RSLT = 000001.

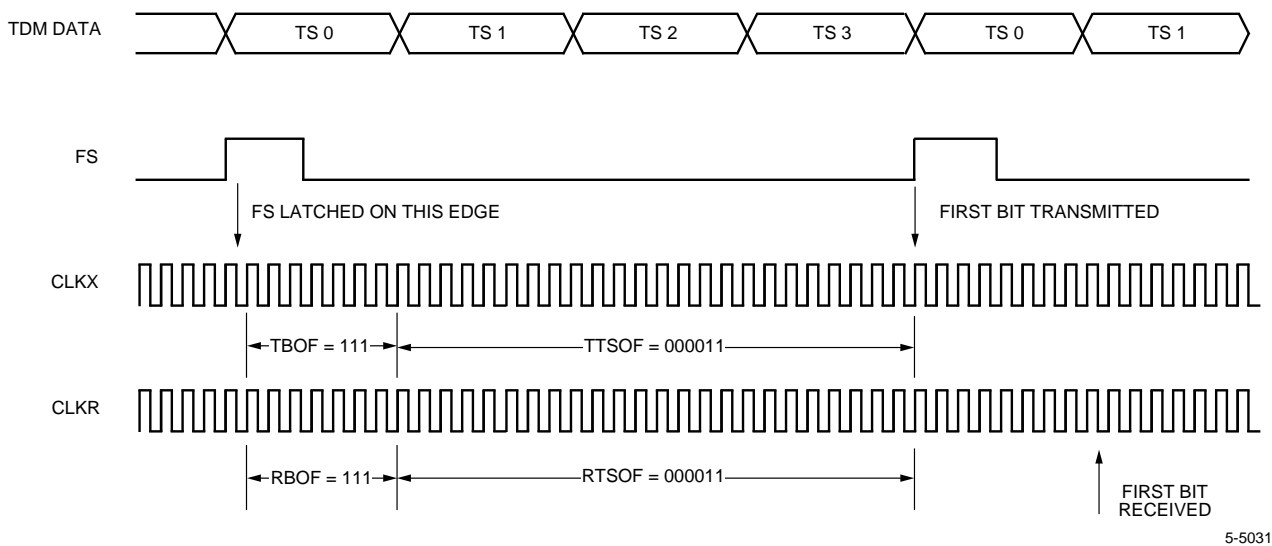

Figure 5. Maximum Bit and Time-Slot Offsets for a Four Time-Slot System

Transmission During Unassigned Time Slots

During time slots when the HIFI-64 is not transmitting, the transmit data output 3-states (an external pull-up resistor is recommended). This also occurs during masked bit times during a time slot (see the Bit Masking section). If pin 17 is configured to \overline{TSCA} , \overline{TSCA} is high during all time slots other than the assigned time slot and during masked bit times in the assigned time slot.

Bit Order During Transmission

Data transmission is normally least significant bit (LSB) first per HDLC protocol specifications. In transparent mode, data is also generated least significant bit first. However, when in the TDM highway mode (HWYEN R0—B7 = 1), the order of transmission and the expected order for receiving can be reversed by programming the TLBIT and RLBIT (R10—B6) and (R11—B6), respectively. These bits can be programmed independently of one another. In other words, the HIFI-64 can be receiving LSB first but transmitting most significant bit (MSB) first, or vice versa. The effect of TLBIT cleared to 0 is to reverse end-for-end the transmitter-generated data before transmission in the time slot. All data is reversed, including flags, aborts, CRC, and user data. The effect of RLBIT cleared to 0 is to reverse end-for-end the time-slot data before passing it to the receiver. RLBIT and TLBIT have no effect on the data unless HWYEN (R0—B7) = 1.

Figures 6 and 7 show how the transmission and reception of data is affected by adjusting TLBIT and RLBIT. The convention used represents user data in the FIFO with lower-case letters and HDLC data as upper-case letters. This convention is meant to indicate only that data in the FIFO and data transmitted or received during the time slot(s) may not be identical bit-for-bit (i.e., zero-bit insertion and deletion—see the HDLC section of this document).

Functional Description (continued)

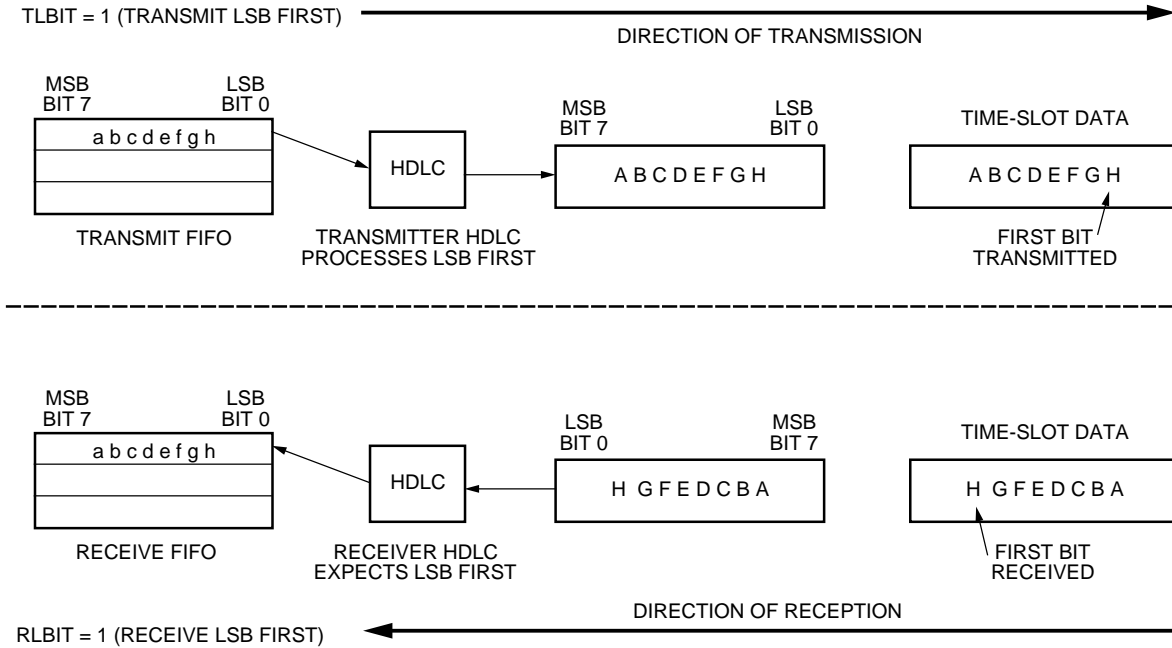

Note: abcdefgh are not the same as ABCDEFGH due to HDLC processing.

5-5032

Figure 6. Transmission and Reception of Data LSB First

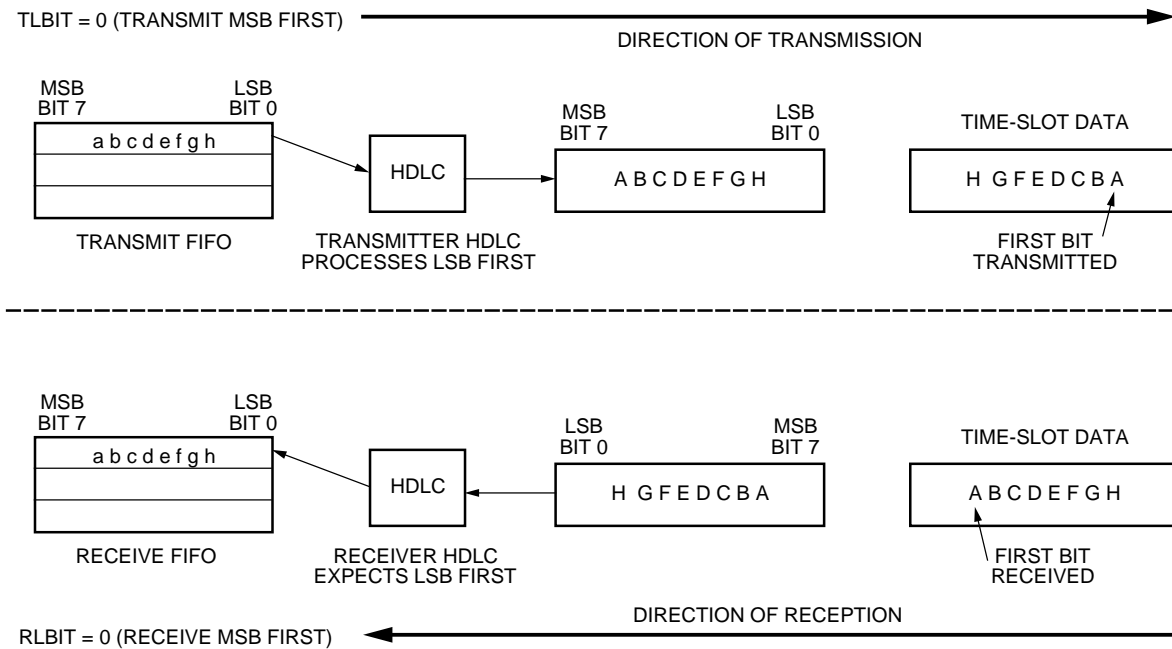

Note: abcdefgh are not the same as ABCDEFGH due to HDLC processing.

5-5033

Figure 7. Transmission and Reception of Data MSB First

Functional Description (continued)

Bit Masking

When in the TDM highway mode (HWYEN, R0—B7 = 1), the HIFI-64 can be programmed to mask any combination of bits in a byte. As an example, this feature is used to process 16 kbits/s D-channel data where only 2 bits in each byte are looked at when receiving, and where only 2 bits are transmitted during an 8-bit time slot. Using this option, the HIFI-64 is able to support effective intermediate data rates of 8, 16, 24, 32, 40, 48, and 56 kbits/s.

The receiver ignores bit positions that are masked (cleared to 0) in the receiver bit mask register (R12). The transmitter outputs high impedance (3-state) during the bit times specified (cleared to 0) in the transmitter bit mask register (R13). The user can program any combination of bits to be masked in the receiver and transmitter independently.

Upon chip reset, the default is as follows:

1. The receiver defaults to recognize all incoming data as valid (i.e., no masking).
2. The transmitter defaults to a state where all bits are masked.

The user must unmask the bits to be transmitted. This eliminates the problem of the HIFI-64 transmitting before the time slot has been programmed in registers 7, 9, and 10.

Figures 8 and 9 show how 16 kbits/s operation is achieved by using the bit-masking option.

Functional Description (continued)

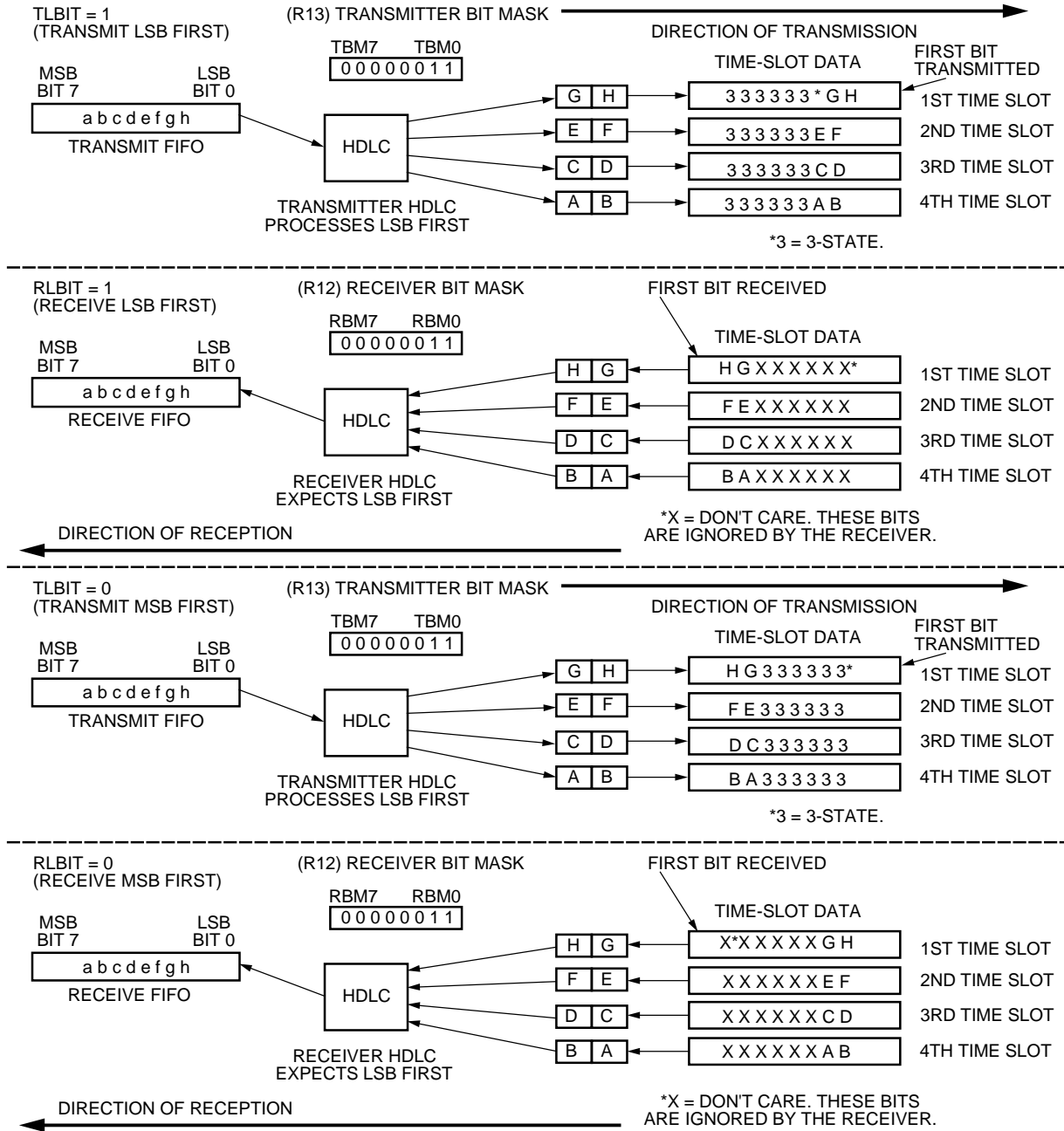

Note: abcdefgh are not the same as ABCDEFGH due to HDLC processing.

5-5034

Figure 8. 16 kbits/s Operation

Functional Description (continued)

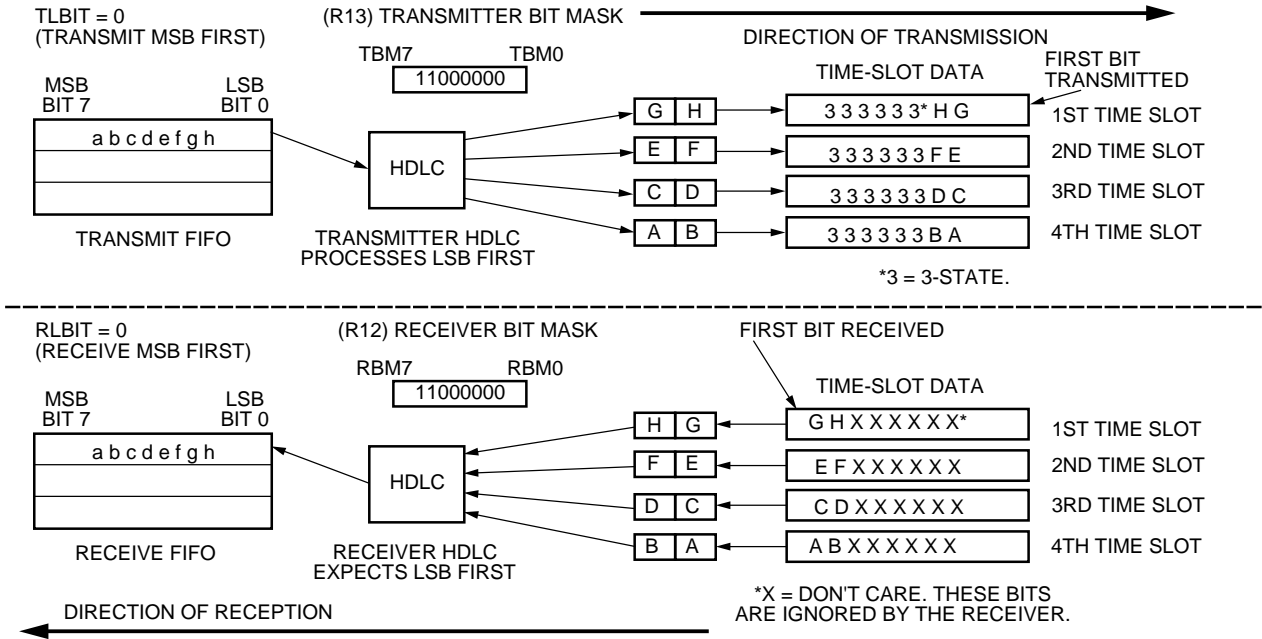

Note: abcdefgh are not the same as ABCDEFGH due to HDLC processing.

5-5035

Figure 9. 16 kbits/s Operation, MSB First

Functional Description (continued)

SLD and IOM2 Examples

Example register settings for configuring to SLD, IOM2, or K2 TDM highways are shown below. These settings assume HWYEN (R0—B7) = 1 and FSPOL (R0—B6) = 1.

Table 4. Example Register Settings

| Register | IOM2/GCI | SLD | K2 |
|--------------------------|-----------------------|---------------|-----------------------|
| FE, (R0—B5) | 0 | 0 | 0 |
| P21CTL, (R5—B6) | 1 | 1 | 1 |
| CMS, (R8—B6) | 1 | 0 | 0 |
| CLKXI, (R9—B4) | 1 | 1 | 1 |
| TBOF[2—0], (R9—B[7—5]) | 111 | 111 | 111 |
| TTSOF[5—0], (R10—B[5—0]) | (# of time slots) – 1 | 000011 | 000000, 000111 |
| TSLT[5—0], (R7—B[5—0]) | Desired time slot | 000000—000011 | 000001—000111, 000000 |
| CLKRI, (R9—B0) | 0 | 0 | 0 |
| RBOF[2—0], (R9—B[3—1]) | 111 | 111 | 111 |
| RTSOF[5—0], (R11—B[5—0]) | (# of time slots) – 1 | 000011 | 000000, 000111 |
| RSLT[5—0], (R8—B[5—0]) | Desired time slot | 000100—000111 | 000001—000111, 000000 |

HDLC Operation

This section describes the standard HDLC functions performed by the HIFI-64. HDLC operation is the default mode of operation. The transmitter accepts parallel data from the transmit FIFO, converts it to a serial bit stream, provides bit stuffing as necessary, adds the CRC and the opening and closing flags, and sends the framed serial bit stream on the selected transmit data pin(s). The receiver accepts serial data on the selected receive data pin, identifies frames for proper format, reconstructs data bytes, provides bit destuffing as necessary, and loads parallel data in the receive FIFO. HDLC frames on the serial link have the following format:

| Opening Flag | User Data Field | Frame Check Sequence (CRC) | Closing Flag |
|--------------|-----------------|----------------------------|--------------|
| 01111110 | ≥8 bits | 16 bits | 01111110 |

All bits between the opening flag and the CRC are considered user data bits. User data bits such as the address, control, and information fields for LAPB or LAPD frames are fetched from the transmit FIFO for transmission. Received user data bits are stored in the FIFO buffers. The 16 bits preceding the closing flag are the frame check sequence or cyclic redundancy check (CRC) bits.

Zero-Bit Insertion/Deletion (Bit Stuffing/Destuffing)

The HDLC protocol recognizes three special bit patterns: flags, aborts, and idles. These patterns have the common characteristic of containing at least six consecutive 1s. A user data byte can contain one of these special patterns. Transmitter zero-bit stuffing is done on user data and CRC fields of the frame to avoid transmitting one of these special patterns. Whenever five 1s occur between flags, a 0 bit is automatically inserted after the fifth 1, prior to transmission of the next bit. On the receive side, if five successive 1s are detected followed by a 0, the 0 is assumed to have been inserted and is deleted (bit destuffing).

T7121 HDLC Interface for ISDN (HIFI-64)

Functional Description (continued)

Flags. All flags have the bit pattern 01111110 and are used for frame synchronization. The HIFI-64 automatically sends two flags between frames. If the FLAGS bit in the chip-configuration register (R0—B2) is cleared to 0, the 1s idle byte (11111111) is sent between frames if no data is present in the FIFO. Once there is data in the transmit FIFO, an opening flag is sent followed by the frame. If the FLAGS bit (R0—B2) is set to 1, the HIFI-64 sends continuous flags when the transmit FIFO is empty. During transmission, two successive flags will not share the intermediate 0. The HIFI-64 does not transmit consecutive frames with a shared flag.

An opening flag is generated at the beginning of a frame (indicated by the presence of data in the transmit FIFO and the transmitter enabled). Data is transmitted per the HDLC protocol until a byte is read from the FIFO with TFC set. The HIFI-64 follows this byte with the CRC sequence and a closing flag.

The receiver recognizes the 01111110 pattern as a flag. Two successive flags may or may not share the intermediate 0 bit and are identified as two flags (i.e., both 011111101111110 and 011111100111110 are recognized by the HIFI-64). The received data bytes are stored in the 64-byte receive FIFO delayed by three bytes or delayed by four bytes if operating in the TDM highway mode (i.e., HWYEN, R0—B7 = 1). When another flag is identified, it is treated as the closing flag. As mentioned above, a flag sequence in the user data or FCS fields is prevented by zero-bit insertion and deletion. The received CRC bytes are not loaded into the receive FIFO. The HIFI-64 receiver recognizes a single flag between frames as both a closing and opening flag.

Aborts. The bit pattern of the abort sequence is 01111111, with 0 transmitted first. A frame can be aborted by writing a 1 to TABT (R1—B6). This causes the last byte written to the transmit FIFO to be replaced with the abort sequence upon transmission. Once a byte is tagged by a write to TABT, it cannot be cleared by subsequent writes to R1. TABT (R1—B6) and TFC (R1—B7) should never be set to 1 simultaneously since this causes the transmitter to enter an invalid state that requires a transmitter reset to clear. A frame should not be aborted in the very first byte following the opening flag. An easy way to avoid this situation is to first write a dummy or junk byte into the queue and then write the abort command to the queue.

When receiving a frame, the receiver recognizes the abort sequence whenever it receives a 0 followed by seven consecutive 1s. This status results in the abort bit, and possibly the bad byte count bit and/or bad CRC

bits, being set in the Status of Frame status byte which is appended to the receive data queue. The last two bytes of user data are assumed to be CRC bits and are not placed in the queue. All subsequent bytes are ignored until a valid opening flag is received.

Idles. In accordance with the HDLC protocol, the HIFI-64 recognizes 15 or more contiguous received 1s as idle. When the HIFI-64 receives 15 contiguous 1s, the receiver idle bit (RIDL, R15—B6) is set in register 15. An interrupt pin transition is generated if no other unmasked interrupts are active and the RIDL interrupt is unmasked; i.e., RIIE (R14—B6) = 1.

For transmission, the 1s idle byte is defined as the binary pattern 11111111 (FF hexadecimal). If the FLAGS control bit in the chip configuration register (R0—B2) is 0, the 1s idle byte is sent as the time-fill byte between frames. A time-fill byte is sent when the transmit FIFO is empty and the transmitter has completed transmission of all previous frames. Frames are sent back-to-back otherwise. If the FLAGS bit (R0—B2) is set to 1, flags (01111110) are sent as the time-fill byte between frames. 1s idle is the default time-fill byte.

Note: Regardless of the time-fill byte used, there always is an opening and closing flag with each frame. Back-to-back frames are separated by two flags.

CRC. For a given frame of bits, 16 additional bits that constitute an error-detecting code are added by the transmitter. As called for in the HDLC protocol, the Frame Check Sequence bits are transmitted most significant bit first and are bit stuffed. The Cyclic Redundancy Check (or Frame Check Sequence) is calculated as a function of the transmitted bits by using the ITU-T standard polynomial:

$$x^{16} + x^{12} + x^5 + 1$$

At the other end, the receiver performs the same calculation on the received bits after destuffing and compares the results to an expected result. An error occurs if, and only if, there is a mismatch.

The transmitter can be instructed to transmit a corrupted CRC by setting the Transmit Bad CRC bit TBCRC (R14—B7). As long as the TBCRC bit is set, the CRC is corrupted for each frame transmitted by logically flipping the least significant bit of the transmitted CRC.

The receiver calculates and verifies the CRC for an incoming frame. The result of the CRC check is reported in bit 7 of the Status of Frame byte which is placed in the receive FIFO after the last data byte of the frame. The CRC is not stored in the FIFO.

Functional Description (continued)

Transmitter FIFO

Data associated with multiple frames can be written to the transmit FIFO by the controlling microprocessor. However, all frames must be explicitly tagged with a Transmit Frame Complete (TFC) bit (R1—B7) or a Transmit Abort (TABT) bit (R1—B6) by writing to register 1. The TFC is tagged onto the last byte of a frame written into the transmitter FIFO. TFC instructs the transmitter to end the frame by attaching the CRC and closing flag following the tagged byte. Once written, the TFC cannot be changed by another write to R1. If TFC is not written before the last data byte is read out for transmission, an underrun occurs. When the FIFO is empty, writing two data bytes to the FIFO before setting TFC provides a minimum of eight CLKX periods to write TFC. TABT (R1—B6) and TFC (R1—B7) should never be set to 1 simultaneously. This causes the transmitter to enter an invalid state requiring a transmitter reset.

When the transmitter has completed a frame, with a closing flag or an abort sequence, the TDONE (R15—B0) bit is set to 1. If TDIE (R14—B0) is 1 and no other prior unacknowledged interrupt exists, the INT pin transitions.

Sending 1-Byte Frames

Sending 1-byte frames with an empty transmit FIFO is not recommended. If the FIFO is empty, writing two data bytes to the FIFO before setting TFC provides a minimum of eight CLKX periods to write TFC. When one byte is written to the FIFO, TFC must be written within 1 CLKX period to guarantee it is effective. Thus, 1-byte frames are subject to underrun aborts. One-byte frames cannot be aborted with TABT. Placing the transmitter in 1s idle mode (FLAGS, R0—B2 = 0) lessens the frequency of underruns. If the transmit FIFO is not empty, then 1-byte frames present no problem.

Transmitter Underrun

After writing a byte to the transmit queue, the user has eight CLKX cycles in which to write the next byte before a transmitter underrun occurs. An underrun occurs when the transmitter has finished transmitting all the bytes in the queue, but the frame has not yet been closed by writing TFC. When a transmitter underrun occurs, the abort sequence is sent at the end of the last valid byte transmitted. A TDONE interrupt is generated, and the transmitter reports an underrun abort in the interrupt status register (R15—B2). The transmitter enters forced idle (sending FLAGS or IDLES based

upon the value in R0—B2) until the interrupt status register (R15) is read.

Using the Transmitter Status and Fill Level

The Transmitter-interrupt Level bits (R1—B[5—0]) allow the user to instruct the T7121 to interrupt the host processor whenever the transmitter has a predetermined number of empty locations. The number of locations selected determines the time between transmitter empty (TE) interrupts. The transmitter status bits (R2—B[6—0]) report the number of empty locations in the transmitter FIFO. The bits are encoded in binary with bit 0 the least significant bit. Also found in register 2 is the Transmitter Empty Dynamic bit, TED (R2—B7). This bit, like the TE interrupt bit, is set when the number of empty locations is less than or equal to the programmed empty level. TED returns to 0 when the transmitter is filled to above the programmed empty level. Polled interrupt systems can use TED to determine when they can write to the transmit FIFO.

Programming Note: After the transmitter is turned off, a transmitter reset should be performed (TRES, R6, bit 5 = 1) before the transmitter is turned on. After the receiver is turned off, a receiver reset should be performed (RRES, R6, bit 4 = 1) before the receiver is turned on. The transmitter and receiver should both be reset individually (i.e., not at the same time) after any concentration highway configuration change. If TRES = RRES = 1 at the same time, a full chip reset is performed: all register bits are forced to their reset values.

Receiver FIFO

The receiver status is available in two ways. First, the queue manager creates a Status of Frame (SF) byte for each HDLC frame and stores this status byte in the FIFO after the last data byte of the associated frame. Thus, a frame containing 24 user data bytes results in 25 bytes present in the receive FIFO. The SF status byte has the following format:

| STATUS OF FRAME BYTE | | | | | | | |
|----------------------|-------|---------|----------------|------|------|------|------|
| BIT7 | BIT6 | BIT5 | BIT4 | BIT3 | BIT2 | BIT1 | BIT0 |
| BAD CRC | ABORT | OVERRUN | BAD BYTE COUNT | 0 | 0 | 0 | 0 |

T7121 HDLC Interface for ISDN (HIFI-64)

Functional Description (continued)

Bit 7 of the SF status byte is the CRC status bit. If an incorrect CRC was detected, this bit is set to 1. If the CRC was correct, the bit is 0.

Bit 6 of the SF status byte is the abort status. A high (1) indicates the frame associated with this status byte was aborted (i.e., the abort sequence was detected after an opening flag and before a subsequent closing flag). An abort can also cause bits 7 and/or 4 to go high (1). An abort is not reported when a flag is followed by seven 1s.

If the Overrun bit (bit 5) is high, it indicates that a receiver FIFO overrun occurred (the 64-byte FIFO size was exceeded; see the Receiver Overrun section).

The Bad Byte Count bit (Bit 4) indicates whether or not the bit count received was a multiple of eight (i.e., an integer number of bytes). A high (1) indicates that the bit count received after 0-bit deletion was not a multiple of eight, and a low indicates that the bit count was a multiple of eight. When a non-byte-aligned frame is received, all bits received are present in the receive FIFO. The byte before the SF status byte contains less than eight valid data bits. The nondata bits are the first bits of the received CRC. The T7121 provides no indication of how many of the bits in the byte are valid. It is up to the user and the protocol to decide what to do with non-byte-aligned frames.

Bits 0 to 3 of the SF status byte are not used and are guaranteed to be 0 when read. A good frame is implied when the SF status byte is 00 hexadecimal.

The last byte of a completed frame in the receive FIFO is always the SF status byte. As a frame is received, the two bytes preceding the closing flag are assumed to be the frame check sequence (CRC) bits and are not loaded into the receiver FIFO. Thus, the final 2 bytes received in an aborted frame are not placed in the queue, and an aborted frame of 2 bytes or less causes only an SF status byte to appear in the receiver FIFO. The writing of the SF status byte is followed by the REOF (R15—B4) interrupt bit being set. The REOF event triggers an interrupt, unless the interrupt is masked by REOFIE (R14—B4) = 0, whenever no other unmasked interrupts are active.

The Receive Queue Status bits (RQS, R4—[6—0]) are updated as bytes are loaded into the receive FIFO. The SF status byte is included in the byte count. When the first SF status byte is placed in the FIFO, the EOF (R4—B7) bit is set, and the status freezes until the FIFO is read. As bytes are read from the FIFO, the status decreases until it reads 1. The byte read when the RQS is "0000001" and the EOF bit is high (1) is the SF status byte describing the error status of the frame just read. Once the first SF status byte is read from the FIFO, the FIFO status is updated to report the number of bytes to the next SF status byte, if any, or the number of additional bytes present. When EOF (R4—B7) is low, no SF status byte is currently present in the FIFO, and the RQS bits report the number of bytes present. As bytes are read from the FIFO, the status decreases with each read until it reads 0 when the FIFO is totally empty. The EOF bit is also low when the FIFO is completely empty. Thus, the RQS and EOF bits provide a mechanism to recognize the end of one frame and the beginning of another. Reading the receiver status register (R4) does not affect the FIFO buffers. In the event of a receiver overrun (see below), an SF status byte is written to the receive FIFO. Multiple SF status bytes can be present in the FIFO. Remember, the RQS reports only the number of bytes to the **first** SF status byte.

To allow users to tailor receiver FIFO service intervals to their systems, the Receiver Interrupt Level bits (RIL, R5—B[5—0]) are provided. These bits are coded in binary and determine when the Receiver Full (RF, R15—B3) interrupt is asserted. The interrupt pin transition can be masked by clearing RFIE, R14—B3 to 0. The value programmed in the RIL bits equals the total number of bytes necessary to be present in the FIFO to trigger an RF interrupt. The RF interrupt alone is not sufficient to determine the number of bytes to read as some of the bytes may be SF status bytes. The RQS bits and EOF bit in register 4 allow the user to determine the number of bytes to read. The REOF interrupt can be the only interrupt for the final frame of a group of frames, since the number of bytes received to the end of the frame cannot be sufficient to trigger an RF interrupt.

Functional Description (continued)

Programming Note: Since the receiver writing to the receive FIFO and the host reading from the receive FIFO are asynchronous events, it is possible for a host read to put the number of bytes in the receive FIFO just below the programmed RIL level and a receiver write to put it back above the RIL level. This causes a new RF interrupt. This has the potential to cause software problems. It is recommended that during service of the RF interrupt, the RF interrupt be masked (RFIE (R14—B3) = 0 and the interrupt register be read at the end of the service routine, discarding any RF interrupt seen, before unmasking the RF interrupt.

Programming Note: After the transmitter is turned off, a transmitter reset should be performed (TRES, R6, bit 5 = 1) before the transmitter is turned on. After the receiver is turned off, a receiver reset should be performed (RRES, R6, bit 4 = 1) before the receiver is turned on. The transmitter and receiver should both be reset individually (i.e., not at the same time) after any concentration highway configuration change. If TRES = RRES = 1 at the same time, a full chip reset is performed: all register bits are forced to their reset values.

Receiver Overrun

A receiver overrun occurs if the 64-byte limit of the receiver FIFO is exceeded, i.e., data has been received faster than it has been read out of the receive FIFO and written to the system memory. Upon overrun, an SF status byte with the overrun bit (bit 5) set replaces the last byte in the FIFO. The SF status byte can have other error conditions present. For example, it is unlikely the CRC is correct. Thus, care should be taken to prioritize the possible frame errors in the software service routine. The last byte in the FIFO is overwritten with the SF status byte regardless of the type of byte (data or SF status) being overwritten. The overrun condition is reported in register 15 (R15—B5) and causes the interrupt pin to be asserted if it is not currently asserted and it is not masked (ROVIE, R14—B5). Data is ignored until the condition is cleared. The overrun condition is cleared by reading register 15 and reading at least 1 byte from the receive FIFO. Because multiple frames can be present in the FIFO, good frames as well as the overrun frame can be present. The host can determine the overrun frame by looking at the SF status byte.

Operational Note (T7121-EL, T7121-PL, T7121-EL2, and T7121-PL2)

In HDLC protocol, binary 1s may be transmitted between frames (interframe fill) when no user data is available. Short bursts of interframe fill, not specified in the current standards, have been encountered when system testing against some switch equipment. Per Lucent's interpretation of the standards, the device will treat received interframe fill from 1 bit to 5 bits in length as a short packet and report a received end of frame condition in register R15, bit 4 (EOF = 1). A hardware interrupt will be generated if the REOF interrupt is enabled in register R14, bit 4 (REOFIE = 1). This may be a performance issue in some systems due to the extra interrupts that the host processor must service, produced by short bursts of interframe fill from 1 bit to 5 bits in length.

The contents of both register R4 (Receiver Status Register) and the receive FIFO depend on the number of interframe 1s received.

If one bit of interframe fill is received, R4 will indicate that an end of frame has occurred, but zero bytes are stored in the receive FIFO (i.e., no Status of Frame byte was written to the FIFO). Data reception can proceed normally without further intervention by the host processor.

If 2 bits to 5 bits of interframe fill are received, R4 will indicate that an end of frame has occurred, and that one byte was stored in the receive FIFO. The 1 byte stored in the FIFO is the Status of Frame byte due to the interframe fill and will have a value of 0x90, indicating a bad CRC and bad byte count. This byte should be read out and discarded. After removing the Status of Frame byte from the FIFO, data reception can proceed normally without further intervention by the host microprocessor.

If 6 bits or more of interframe fill are received, the device correctly ignores these bits. The FIFO is not written and no interrupts are generated.

T7121 HDLC Interface for ISDN (HIFI-64)

Functional Description (continued)**Transparent Mode**

The HIFI-64 can be programmed to operate in the transparent mode by setting the TRANS bit (AR11—B6) to 1. In the transparent mode of operation, no HDLC processing is performed on user data. The transparent mode can be exited at any time by clearing the TRANS bit to 0. It is recommended that the transmitter be disabled (ENT, R6—B3 = 0) when changing in and out of transparent mode. The transmitter should be reset by a TRES whenever the mode is changed.

Three alternate registers are provided to control operation in the transparent mode:

AR11—Transparent Mode Control

AR12—Receive Match Character

AR13—Transmitter Idle Character

The alternate registers are accessed by setting the ALT bit (R0—B4) to 1. All subsequent addressing of registers 11 through 13 then refer to the alternate registers (AR11—AR13). Returning to the foreground register set is accomplished by clearing the ALT bit (R0—B4) to 0.

In the transmit direction, the HIFI-64 takes data from the transmit FIFO and transmits that data exactly bit for bit on the DXA pin, the DXB pin, or both, depending on the configuration of the DXAC and DXBC bits in register 7 (R7—B6, B7). When there is no data in the transmit FIFO, the HIFI-64 either transmits all 1s, or transmits the transmitter idle character programmed in AR13 if the MATCH bit (AR11—B5) is set to 1. To cause the transmit idle character to be sent first, the character must be programmed in AR13 before the transmitter is enabled. **In non-TDM highway modes, the transmit idle character or the 1s idle character is always sent first, even if data is present in the FIFO.** In TDM highway mode, the first character transmitted is FF hexadecimal regardless of the mode. The bits are transmitted least significant bit first in non-TDM highway mode (HWYEN, R0—B7 = 0). In TDM highway modes (HWYEN = 1), the TLBIT (R10—B6) determines the bit transmission order. Subrate operation using the transmit bit mask is also supported. The transmitter empty (TE) interrupt acts normal.

The transmitter-done interrupt (TDONE) is used to report an empty transmit FIFO. The TDONE interrupt thus provides a way to determine transmission end. In transparent mode, a TDONE interrupt is generated when the transmitter is reset, as does a TE interrupt. The UNDABT interrupt is not active in transparent mode.

If the HIFI-64 is in the TDM highway mode (HWYEN, R0—B7 = 1), transmit data is octet-aligned to the selected time slot. If HWYEN = 0, transmit data is octet-aligned to the first CLKX after the transmitter has been enabled (ENT, R6—B3 = 1). See Figure 3 for details of clock start-up in non-TDM highway modes.

In the receive direction, the HIFI-64 loads received data from the DRA or DRB pin (depending on the configuration of the DRA/B bit in register 8 [R8—B7]) directly into the receive FIFO bit for bit. In non-TDM highway modes, the data is assumed to be least significant bit first. In TDM highway mode, the RLBIT (R11—B6) controls the bit order. If the MATCH bit (AR11—B5) is 0, the receiver begins loading data into the receive FIFO, beginning with the first CLKR detected after the receiver has been enabled (ENR, R6—B2 = 1). If the MATCH bit (AR11—B5) is set to 1, the receiver does not begin loading data into the FIFO until the receiver match character programmed in AR12 has been detected. The search for the receiver match character is in a sliding window fashion if the ALOCT (Align to Octet) bit (AR11—B4) is 0, or only on octet boundaries if the ALOCT bit is set to 1. The octet boundary is aligned to the receive time slot if HWYEN (R0—B7) = 1 or relative to the first CLKR after the receiver has been enabled (ENR, R6—B2 = 1), if HWYEN (R0—B7) = 0. The matched character and all subsequent bytes are placed in the receive FIFO. A receiver reset RRES causes the receiver to realign to the match character if MATCH is set.

The receiver full (RF) and receiver overrun (OVERUN) interrupts act as normal. The received end of frame (REOF) and receiver idle (RIDL) interrupts are not used in the transparent mode. The match status (MSTAT) bit (AR11—B4) is set to 1 when the receiver match character is first recognized. If the MATCH bit (AR11—B5) is 0, the MSTAT bit (AR11—B4) is set to 1 automatically when the first bit is received, and the octet offset status bits (AR11—B[0—2]) read 000. If the MATCH bit (AR11—B5) is programmed to 1, the MSTAT bit (AR11—B4) is set to 1 upon recognition of the first receiver match character, and the octet offset status bits (AR11—B[0—2]) indicate the offset relative to the octet boundary at which the receiver match character was recognized. The octet offset status bits have no meaning until the MSTAT bit is set to 1. An octet offset of 111 indicates byte alignment.

An interrupt for recognition of the match character can be generated by setting the RIL level to 1. Since the matched character is the first byte written to the FIFO, the RF interrupt occurs with the writing of the match character to the receive FIFO.

Functional Description (continued)

Programming Note: The match bit (MATCH) affects both the transmitter and the receiver. Care should be taken to correctly program both the transmit idle character and the receive match character before setting MATCH. If the transmit idle character is programmed to FF hex, the MATCH bit appears to affect only the receiver.

The operation of the receiver in transparent mode is summarized in Table 5.

Table 5. Receiver Operation in Transparent Mode

| HWYEN (R0—B7) | ALOCT (AR11—B4) | MATCH (AR11—B5) | Receiver Operation |
|------------------|--------------------|--------------------|---|
| 0 | X | 0 | Serial-to-parallel conversion begins with first CLKR after ENR is set. Data loaded to receive FIFO immediately. |
| 0 | 0 | 1 | Match user-defined character (AR12) using sliding window. Byte aligns once character is recognized. No data to receive FIFO until match is detected. |
| 0 | 1 | 1 | Match user-defined character (AR12), but only on octet boundary. Boundary based on first CLKR after ENR set. No data to receive FIFO until match is detected. |
| 1 | X | 0 | Byte aligns to time slot. No match necessary. Data loaded to receive FIFO immediately. |
| 1 | 0 | 1 | Match user-defined character (AR12) using sliding window. Byte aligns once character is recognized. No data to receive FIFO until match is detected. |
| 1 | 1 | 1 | Match user-defined character (AR12) to byte received in time slot. No data to receive FIFO until match is detected. |

Diagnostic Modes

Loopbacks

The serial link interface can operate in two diagnostic loopback modes: (1) local loopback and (2) remote loopback. The local loopback mode is selected when the LLOOP bit is set to 1 in the operation control register (R6—B1). The remote loopback is selected when the RLOOP bit is set to 1 in the operation control register (R6—B0). For normal traffic, i.e., to operate the transmitter and receiver independently, the LLOOP bit and the RLOOP bit should both be cleared to 0. Loopbacks are available in both TDM highway and non-TDM highway modes. Do not simultaneously attempt local and remote loopbacks.

Either DRA or DRB can be used for receive data, based on the value of the DRA/B bit in register 8 (R8—B7). DXA or DXB or both can be selected for transmit data, depending on the values programmed for the DXAC and DXBC bits in register 7 (R7—B6 and R7—B7).

Functional Description (continued)

In the local loopback mode:

- CLKRI (R9—B0) must equal CLKXI (R9—B4). We recommend changing CLKRI to match CLKXI (other highway parameters need not be altered).
- CLKX clocks both the transmitter and the receiver.
- The transmitter and receiver must both be enabled. The transmitter output is internally connected to the receiver input.
- The DXA and DXB outputs are active, depending on DXAC and DXBC.
- The DRA or DRB input is ignored.
- The communication between the transmit and receive FIFO buffers and the microprocessor continues normally.

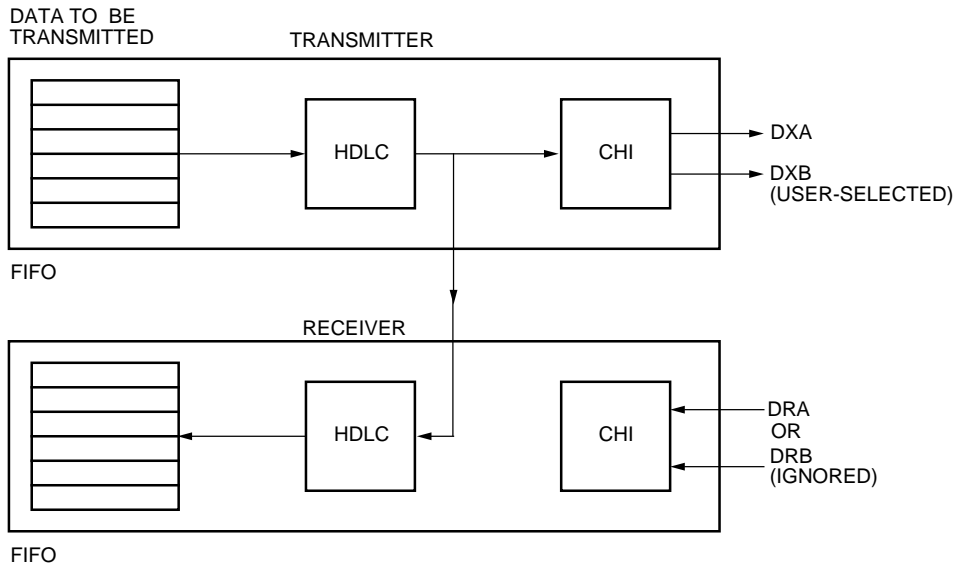

5-5036

Figure 10. Local Loopback Mode

Functional Description (continued)

In the remote loopback mode:

CLKR must equal or be synchronous with CLKX. We recommend clocking both transmit and receive data with CLKX (R5—B6 set to 1).

- Receive and transmit bit masks (R12 and R13) should be programmed to the same value.
- Transmitted data is retimed. If HWYEN = 0 (R0—B7), the transmitted data is retimed with a maximum delay of 2 bits. If HWYEN = 1 (R0—B7), the received data is transmitted in the first programmed time slot after the receive time slot is complete.
- Received data is retransmitted on the DXA and/or the DXB output, depending on DXAC and DXBC.
- The transmitter should be disabled. The receiver can be disabled or, if desired, enabled. Received data is sent as usual to the receive FIFO if the receiver is enabled.

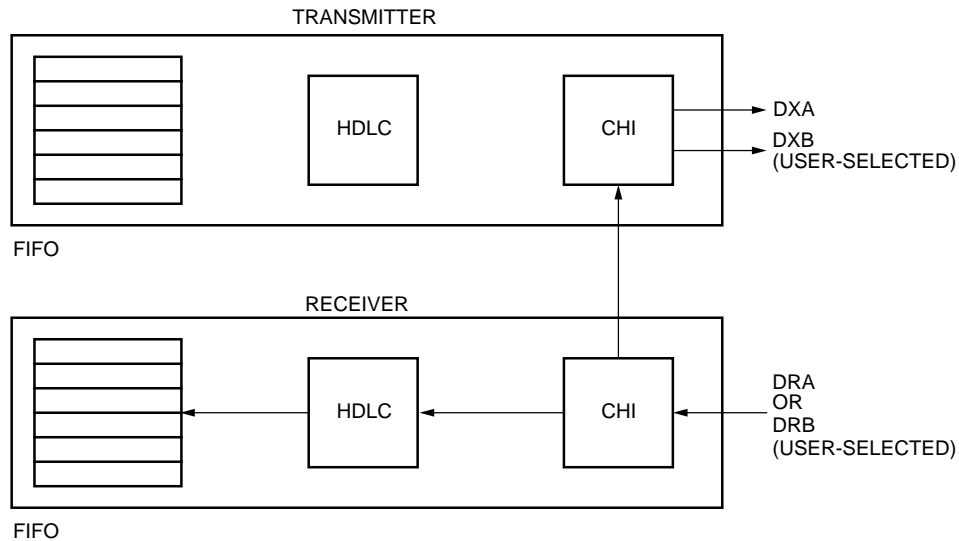

5-5037

Figure 11. Remote Loopback Mode

CAUTION: Do not use local and remote loopback modes at the same time. Such use results in an unknown state in the chip which only a full reset of the chip can clear.

Functional Description (continued)

3-State Mode

The HIFI-64 can be placed in a high-impedance mode for test purposes. In this configuration, all output pins are placed in a 3-state condition. This can be accomplished in two different ways:

1. Asserting the RESET pin 3-states all outputs, clears both the transmit and receive FIFOs, and resets all internal registers to their default values. A full chip reset occurs with or without a clock input.
2. Setting the 3STATE bit (R6—B6) to 1 3-states all outputs without affecting the states of internal registers and FIFOs. This state lasts until both \overline{CS} and \overline{RD} are held low; that is, the first read of the HIFI-64 resets the 3STATE bit regardless of the register address. Registers can be written while the 3STATE bit is enabled.

Setting the receiver reset (RRES) and the transmitter reset (TRES) bits in the operation control register (R6—B4,B5) to 1 simultaneously causes a FIFO and register reset to reset values (outputs are not 3-stated).

Other

The HIFI-64 can be instructed to transmit a bad CRC for test purposes by programming the TBCRC bit in register 14 (R14—B7) to 1. Bad CRCs are transmitted until the TBCRC bit is cleared. The TEST bit in AR11 is used for manufacture testing and should always be programmed low (0) by the host microprocessor.

Powerdown Mode

The HIFI-64 can be placed in a low-power mode when not in use by setting the PDWN bit in register 6 (R6—B7) to 1. This has the effect of stopping data clock input signals (CLKR and CLKX) from propagating internally and results in very low power dissipation. Reads and writes to the HIFI-64 can continue normally. The low-power mode is exited by clearing the PDWN bit (R6—B7) to 0.

Registers

The HIFI-64 contains 19 registers (R0—R15 and AR11—AR13). Registers 11, 12, and 13 have alternate meanings depending on the value of the ALT bit in the Chip Configuration Register (R0—B4). The alternate registers are accessed by setting the ALT bit (R0—B4) to 1. All subsequent addressing of registers 11 through 13 then refers to the alternate registers (AR11—AR13). Returning to the foreground register set is accomplished by clearing the ALT bit (R0—B4) to 0. The primary function of the alternate registers is for transparent-mode operation.

A summary of the HIFI-64 register set is given in Table 6.

Functional Description (continued)

Table 6. HIFI-64 Register Summary

| Reg# | R/W | Bit 7 | Bit 6 | Bit 5 | Bit 4 | Bit 3 | Bit 2 | Bit 1 | Bit 0 |
|--|-----|--------|--------|--------|--------|--------|--------|--------|--------|
| Chip Configuration | | | | | | | | | |
| R0 | R/W | HWYEN | FSPOL | FE | ALT | BM | FLAGS | IPOL | DINT |
| Transmitter Control | | | | | | | | | |
| R1 | R/W | TFC | TABT | TIL5 | TIL4 | TIL3 | TIL2 | TIL1 | TIL0 |
| Transmitter Status | | | | | | | | | |
| R2 | R | TED | TQS6 | TQS5 | TQS4 | TQS3 | TQS2 | TQS1 | TQS0 |
| Data Byte | | | | | | | | | |
| R3 | R/W | DATA7 | DATA6 | DATA5 | DATA4 | DATA3 | DATA2 | DATA1 | DATA0 |
| Receiver Status | | | | | | | | | |
| R4 | R | EOF | RQS6 | RQS5 | RQS4 | RQS3 | RQS2 | RQS1 | RQS0 |
| Receiver Control | | | | | | | | | |
| R5 | R/W | P17CTL | P21CTL | RIL5 | RIL4 | RIL3 | RIL2 | RIL1 | RIL0 |
| Operation Control | | | | | | | | | |
| R6 | R/W | PDWN | 3STATE | TRES | RRES | ENT | ENR | LLOOP | RLOOP |
| Transmit Time-Slot Control | | | | | | | | | |
| R7 | R/W | DXAC | DXBC | TSLT5 | TSLT4 | TSLT3 | TSLT2 | TSLT1 | TSLT0 |
| Receiver Time-Slot Control | | | | | | | | | |
| R8 | R/W | DRA/B | CMS | RSLT5 | RSLT4 | RSLT3 | RSLT2 | RSLT1 | RSLT0 |
| Bit Offset Control | | | | | | | | | |
| R9 | R/W | TBOF2 | TBOF1 | TBOF0 | CLKXI | RBOF2 | RBOF1 | RBOF0 | CLKRI |
| Transmit Time-Slot-Offset Control | | | | | | | | | |
| R10 | R/W | DXI | TLBIT | TTSOF5 | TTSOF4 | TTSOF3 | TTSOF2 | TTSOF1 | TTSOF0 |
| Receive Time-Slot-Offset Control | | | | | | | | | |
| R11 | R/W | DRI | RLBIT | RTSOF5 | RTSOF4 | RTSOF3 | RTSOF2 | RTSOF1 | RTSOF0 |
| Transparent-Mode Control | | | | | | | | | |
| AR11 | R/W | TEST | TRANS | MATCH | ALOCT | MSTAT | OCTOF2 | OCTOF1 | OCTOF0 |
| Receiver Bit Mask | | | | | | | | | |
| R12 | R/W | RBM7 | RBM6 | RBM5 | RBM4 | RBM3 | RBM2 | RBM1 | RBM0 |
| Receive Match Character | | | | | | | | | |
| AR12 | R/W | RMC7 | RMC6 | RMC5 | RMC4 | RMC3 | RMC2 | RMC1 | RMC0 |
| Transmitter Bit Mask | | | | | | | | | |
| R13 | R/W | TBM7 | TBM6 | TBM5 | TBM4 | TBM3 | TBM2 | TBM1 | TBM0 |
| Transmitter Idle Character | | | | | | | | | |
| AR13 | R/W | TIC7 | TIC6 | TIC5 | TIC4 | TIC3 | TIC2 | TIC1 | TIC0 |
| Interrupt Mask | | | | | | | | | |
| R14 | R/W | TBCRC | RIIE | ROVIE | REOFIE | RFIE | UNDIE | TEIE | TDIE |
| Interrupt Status | | | | | | | | | |
| R15 | R | 0 | RIDL | OVERUN | REOF | RF | UNDABT | TE | TDONE |

Functional Description (continued)**Table 7. Register R0—Chip Configuration Register**

| R0—B7 | R0—B6 | R0—B5 | R0—B4 | R0—B3 | R0—B2 | R0—B1 | R0—B0 |
|---------------|--------------|-----------|------------|-----------|--------------|-------------|-------------|
| HWYEN (0)* | FSPOL (1) | FE (0) | ALT (0) | BM (0) | FLAGS (0) | IPOL (0) | DINT (0) |

| Register | Bit | Symbol | Name/Function |
|----------|-----|--------|---|
| R0 | B0 | DINT | Dynamic Interrupt. When this bit is 0, the interrupt bits in the interrupt status register (R15) are cleared by a read of R15. The condition causing the interrupt must go away and occur again in order for this interrupt to reassert. Setting this bit to 1 causes the RF and TE bits in R15 and the INT pin to behave dynamically. See register 15 for more details. |
| R0 | B1 | IPOL | Interrupt Polarity. Setting this bit to 1 specifies that the hardware INT signal (pin 15) is active-high. If this bit is 0, the INT signal is active-low. |
| R0 | B2 | FLAGS | Flags. This bit specifies whether the flag pattern (01111110) or the idle pattern (11111111) is transmitted in the absence of transmit data. When this bit is cleared to 0, idles are sent, and when this bit is set to 1, flags are sent. This bit is active only in HDLC mode. |
| R0 | B3 | BM | Block Move. Setting this bit to 1 allows block moves to both the transmit and receive FIFOs. The block-move feature is available only with the multiplexed address/data bus since it depends on the AD6 pin. |
| R0 | B4 | ALT | Alternate. Registers 11 through 13 have alternate meanings depending on the value of this bit. The alternate registers (AR11—AR13) are accessed by setting this bit to 1. All subsequent addressing of registers 11 through 13 then refers to the alternate registers (AR11—AR13). Returning to registers (R11—R13) is accomplished by clearing this bit to 0. |
| R0 | B5 | FE | Frame Edge. When this bit is set to 1, the frame-synchronization strobe (FS) is sampled on the positive-going edge of the bit clock (CLKX). When this bit is cleared to 0, FS is sampled on the negative-going edge of CLKX. |
| R0 | B6 | FSPOL | Frame-Sync Polarity. When this bit is set to 1, the rising edge of FS indicates the beginning of a frame. When this bit is cleared to 0, the negative edge of FS indicates the beginning of a frame. |
| R0 | B7 | HWYEN | TDM Highway Enable. Setting this bit to 1 allows the HIFI-64 to communicate with a TDM bus or highway. When this bit is cleared to 0, the time-slot features are turned off, and the HIFI-64 receive and transmit operations are controlled by the CLKX and CLKR inputs. |

* Numbers in parentheses indicate the value of each bit upon being reset.

Functional Description (continued)

Table 8. Register R1—Transmitter Control Register

| R1—B7 | R1—B6 | R1—B5 | R1—B4 | R1—B3 | R1—B2 | R1—B1 | R1—B0 |
|------------|-------------|-------------|-------------|-------------|-------------|-------------|-------------|
| TFC (0) | TABT (0) | TIL5 (0) | TIL4 (0) | TIL3 (0) | TIL2 (0) | TIL1 (0) | TIL0 (0) |

| Register | Bit | Symbol | Name/Function |
|----------|--------|-----------|--|
| R1 | B(0—5) | TIL0—TIL5 | Transmitter Interrupt Level. These bits specify the minimum number of empty positions in the transmit FIFO which triggers a transmitter-empty (TE) interrupt. Encoding is in binary, bit 0 is the LSB. A code of 001010, for example, means an interrupt is generated when the transmit FIFO has ten or more empty locations. The code 000000 is a special case and means a TE interrupt is generated only when the transmit FIFO is actually empty. The exact number of empty locations can be obtained by reading the transmitter status register (R2). |
| R1 | B6* | TABT | Transmit Abort. Setting this bit to 1 instructs the internal HDLC transmitter to abort the frame at the last user data byte waiting for transmission. When the transmitter reads the byte tagged with TABT, it sends the abort sequence (01111111) in place of that byte. A full byte is guaranteed to be transmitted. The last value written to TABT is available for reading. Clearing this bit to 0 has no effect on a previously written TABT, i.e., once set for a specific data byte, TABT cannot be cleared by writing to register 1. |
| R1 | B7* | TFC | Transmit Frame Complete. Setting this bit to 1 instructs the internal HDLC transmitter to close the frame normally after the last user data byte written to the transmit FIFO. The CRC sequence and a closing flag are appended. This bit should be set within eight CLKX periods of writing the last data byte of the frame to the queue. When the FIFO is empty, writing two data bytes to the FIFO before setting TFC provides a minimum of eight CLKX periods to write TFC. The last value written to TFC is available for reading. Clearing this bit to 0 has no effect on a previously written TFC, i.e., once set for a specific data byte, TFC cannot be cleared by writing to R1. TFC does not need to be written to 0 to begin a new frame. |

* Do not set TABT and TFC to 1 at the same time.

Functional Description (continued)**Table 9. Register R2—Transmitter Status Register**

| R2—B7 | R2—B6 | R2—B5 | R2—B4 | R2—B3 | R2—B2 | R2—B1 | R2—B0 |
|------------|-------------|-------------|-------------|-------------|-------------|-------------|-------------|
| TED (1) | TQS6 (1) | TQS5 (1) | TQS4 (1) | TQS3 (1) | TQS2 (1) | TQS1 (1) | TQS0 (1) |

| Register | Bit | Symbol | Name/Function |
|----------|--------|-----------|--|
| R2 | B(0—6) | TQS0—TQS6 | Transmit Queue Status. Read only. Bits 0—6 indicate how many bytes can be added to the transmit FIFO. The bits are encoded in binary, with bit 0 being the LSB. |
| R2 | B7 | TED | Transmitter Empty Dynamic. Read only. When this bit is high, it indicates that the number of empty locations available in the transmit FIFO is greater than or equal to the value programmed in the TIL bits (see register 1). This bit is cleared only when the transmit FIFO is loaded above the preprogrammed empty-trigger level. |

Table 10. Register R3—Data Byte Register

| R3—B7 | R3—B6 | R3—B5 | R3—B4 | R3—B3 | R3—B2 | R3—B1 | R3—B0 |
|-------|-------|-------|-------|-------|-------|-------|-------|
| DATA7 | DATA6 | DATA5 | DATA4 | DATA3 | DATA2 | DATA1 | DATA0 |

| Register | Bit | Symbol | Name/Function |
|----------|--------|-------------|---|
| R3 | B(0—7) | DATA0—DATA7 | The user data bytes to be transmitted are loaded through this register (write). Also, the user data bytes received are accessed through this register (read). |

Note: A special block-move mode allows data to be loaded as a block to the FIFO. A block move is accomplished only in the MUXed address and data mode by setting the BM bit in register 0 (R0—B3) to 1 and holding AD6 high during the address cycle of the ALE. All writes then go directly to the transmit FIFO and all reads address the receive FIFO. Normal ALE mode addressing is accomplished by holding AD6 low during the ALE address cycle. Block move is enabled and disabled by the BM bit in register 0 (R0—B3).

Functional Description (continued)

Table 11. Register R4—Receiver Status Register

| R4—B7 | R4—B6 | R4—B5 | R4—B4 | R4—B3 | R4—B2 | R4—B1 | R4—B0 |
|------------|-------------|-------------|-------------|-------------|-------------|-------------|-------------|
| EOF (0) | RQS6 (0) | RQS5 (0) | RQS4 (0) | RQS3 (0) | RQS2 (0) | RQS1 (0) | RQS0 (0) |

| Register | Bit | Symbol | Name/Function |
|----------|--------|-----------|--|
| R4 | B(0—6) | RQS0—RQS6 | Receive Queue Status. Read only. Bits 0—6 indicate how many bytes are available in the receive FIFO, including the first Status of Frame (SF) byte. If no SF byte exists in the queue, these 7 bits indicate the number of bytes in the queue. The bits are encoded in binary with bit 0 being the LSB. |
| R4 | B7 | EOF | End of Frame. Read only. This flag is set when an SF byte exists in the receive FIFO. When EOF is set, the receive queue status reflects the number of bytes up to and including the first SF byte. |

Functional Description (continued)**Table 12. Register R5—Receiver Control Register**

| R5—B7 | R5—B6 | R5—B5 | R5—B4 | R5—B3 | R5—B2 | R5—B1 | R5—B0 |
|---------------|---------------|-------------|-------------|-------------|-------------|-------------|-------------|
| P17CTL (0) | P21CTL (0) | RIL5 (0) | RIL4 (0) | RIL3 (0) | RIL2 (0) | RIL1 (0) | RIL0 (0) |

| Register | Bit | Symbol | Name/Function |
|----------|--------|-----------|---|
| R5 | B(0—5) | RIL0—RIL5 | Receiver Interrupt Level. These bits determine when a receiver full (RF) interrupt is triggered. The value programmed in RIL equals the number of bytes in the receive FIFO which triggers an RF interrupt. For example, a code of 001111 means an interrupt is generated when the receive FIFO contains 15 or more bytes. The code 000000 is a special case and means an interrupt is generated only when the receive FIFO is actually full. |
| R5 | B6 | P21CTL | Pin 21 Control. This bit controls the functionality of pin 21. When this bit is set to 1, pin 21 is configured as DRB, and received data is clocked by CLKX. When this bit is cleared to 0, pin 21 is configured as CLKR and provides the timing for received data. |
| R5 | B7 | P17CTL | Pin 17 Control. This bit controls the functionality of pin 17. When this bit is cleared to 0, pin 17 is configured as DXB output. In this configuration, data is transmitted on DXB. When this bit is set to 1, pin 17 is configured as \overline{TCSA} . This overrides the setting of DXBC (R7—B6). In this configuration, data can only be transmitted on TDM highway A through the DXA pin (pin 19). If HWYEN (R0—B7) is 0, \overline{TCSA} is continuously low. |

Functional Description (continued)

Table 13. Register R6—Operation Control Register

| R6—B7 | R6—B6 | R6—B5 | R6—B4 | R6—B3 | R6—B2 | R6—B1 | R6—B0 |
|-------------|---------------|-------------|-------------|------------|------------|--------------|--------------|
| PDWN (0) | 3STATE (0) | TRES (0) | RRES (0) | ENT (0) | ENR (0) | LLOOP (0) | RLOOP (0) |

| Register | Bit | Symbol | Name/Function |
|----------|-----|--------|---|
| R6 | B0* | RLOOP | Remote Loopback. Setting this bit to 1 loops the received data back to the distant end. When this bit is 0, normal transmission occurs. |
| R6 | B1* | LLOOP | Local Loopback. Setting this bit to 1 loops transmitted data to the internal receiver. The receive data pin input (either DRA or DRB) is ignored. Clearing this bit to 0 allows normal transmission. |
| R6 | B2 | ENR | Enable Receiver. When this bit is set to 1, the received data is processed by the receiver. When this bit is cleared to 0, incoming data is ignored. |
| R6 | B3 | ENT | Enable Transmitter. When this bit is set to 1, the transmitter is enabled, and user data is transmitted on the selected transmit data pin(s). If no transmit data pin is selected, the transmitter empties while the output pins are 3-stated. When this bit is cleared to 0, the transmitter is disabled. See Table 3. |
| R6 | B4 | RRES | Receiver Reset. Write only. Setting this bit to 1 generates an internal pulse that resets the HDLC receiver. The receive FIFO and related status bits are cleared. The REOF, RF, RIDLE, and OVERRUN interrupts are cleared. The receiver is placed in a known state. |
| R6 | B5† | TRES | Transmitter Reset. Write only. Setting this bit to 1 generates an internal pulse that resets the HDLC transmitter. The transmit FIFO's status bits are initialized and the transmitter enters a known state. The UNDABT interrupt is cleared and the TE interrupt is set. TDONE is cleared in HDLC mode and set in transparent mode. |
| R6 | B6 | 3STATE | 3STATE. This bit places all HIFI-64 outputs into a high-impedance (3-state) state. This state lasts until both \overline{CS} and \overline{RD} are detected low simultaneously. |
| R6 | B7 | PDWN | Powerdown. Setting this bit to 1 places the HIFI-64 into a low-power mode. This has the effect of stopping the internal data clock and results in significantly reduced power dissipation. |

* RLOOP and LLOOP should not be set to 1 simultaneously.

† Setting RRES and TRES simultaneously returns the registers to their default values without causing the outputs to 3-state.

T7121 HDLC Interface for ISDN (HIFI-64)

Functional Description (continued)

Table 14. Register R7—Transmit Time-Slot Control Register

| R7—B7 | R7—B6 | R7—B5 | R7—B4 | R7—B3 | R7—B2 | R7—B1 | R7—B0 |
|-------------|-------------|--------------|--------------|--------------|--------------|--------------|-------------|
| DXAC (0) | DXBC (0) | TSLT5 (0) | TSLT4 (0) | TSLT3 (0) | TSLT2 (0) | TSLT1 (0) | TSLT (0) |

| Register | Bit | Symbol | Name/Function |
|----------|--------|-------------|--|
| R7 | B(0—5) | TSLT0—TSLT5 | Transmitter Time Slot. These 6 bits, representing a value from 0 to 63, coded in binary with bit 0 the LSB, define the transmit time-slot number for transmission on the chosen pin (DXA and/or DXB). |
| R7 | B6* | DXBC | Transmit Data DXB Control. When this bit is set to 1, data is transmitted on the DXB pin (pin 17). Setting P17CTL (R5 B7) to 1 overrides the setting of DXBC. |
| R7 | B7* | DXAC | Transmit Data DXA Control. When this bit is set to 1, data is transmitted on the DXA pin (pin 19). |

* The HIFI-64 can transmit on either DXA, DXB, or both. If both pins are selected via these register bits, the same data byte is sent during the same time slot on both pins.

Table 15. Register R8—Receiver Time-Slot Control Register

| R8—B7 | R8—B6 | R8—B5 | R8—B4 | R8—B3 | R8—B2 | R8—B1 | R8—B0 |
|--------------|------------|--------------|--------------|--------------|--------------|--------------|--------------|
| DRA/B (0) | CMS (0) | RSLT5 (0) | RSLT4 (0) | RSLT3 (0) | RSLT2 (0) | RSLT1 (0) | RSLT0 (0) |

| Register | Bit | Symbol | Name/Function |
|----------|--------|-------------|--|
| R8 | B(0—5) | RSLT0—RSLT5 | Receiver Time Slot. These 6 bits, representing a value from 0 to 63, coded in binary with bit 0 the LSB, define the receive time-slot number for information received on the chosen receive data pin (DRA or DRB). |
| R8 | B6 | CMS | Clock Mode Select. When set to 1, this bit allows the HIFI-64 to communicate with an IOM2 or GCI interface by effectively dividing the data clock internally by two. (See the serial link interface section for details on configuring to IOM2 interface.) |
| R8 | B7 | DRA/B | Receive Data on DRA or DRB. This bit determines which pin the HIFI-64 receiver uses to access received data. When this bit is 0, received data is expected on the DRA pin. When this bit is set to 1, received data is expected on the DRB pin. (This option implies P21CTL [R5—B6] is set to 1.) |

Functional Description (continued)

Table 16. Register R9—Bit Offset Control Register

| R9—B7 | R9—B6 | R9—B5 | R9—B4 | R9—B3 | R9—B2 | R9—B1 | R9—B0 |
|--------------|--------------|--------------|--------------|--------------|--------------|--------------|--------------|
| TBOF2 (0) | TBOF1 (0) | TBOF0 (0) | CLKXI (0) | RBOF2 (0) | RBOF1 (0) | RBOF0 (0) | CLKRI (1) |

| Register | Bit | Symbol | Name/Function |
|----------|--------|-------------|---|
| R9 | B0 | CLKRI | Receive Clock Invert. When this bit is cleared to 0, data is received (latched) on the falling edge of CLKR (or CLKX if R5 B6 is set to 1). If this bit is set to 1, data is received (latched) on the rising edge of CLKR (or CLKX). |
| R9 | B(1—3) | RBOF0—RBOF2 | Receiver Bit Offset. These 3 bits provide a fixed offset relative to the position of the first receivable bit after the frame-sync signal. The position of the first receivable bit is dependent upon the clock edge used for latching received data. See Figures 13—21 for placement of the first receivable bit. The offset is the number of receive data periods needed to align with the first bit of a time slot counting from the first receivable bit. All subsequent receptions also follow this offset. See Table 6 for an example of using RBOF. |
| R9 | B4 | CLKXI | Transmit Clock Invert. When this bit is cleared to 0 (default), data is transmitted on the falling edge of CLKX. If this bit is set to 1, data is transmitted on the rising edge of CLKX. |
| R9 | B(5—7) | TBOF0—TBOF2 | Transmitter Bit Offset. These 3 bits provide a fixed offset relative to the position of the first transmittable bit position after the frame-synchronization pulse. The position of the first transmittable bit varies with the edge of CLKX used for data transmission. See Figures 13—21 for placement of the first transmittable bit position. The offset is the number of transmit data periods needed to align with the first bit of a time slot. All subsequent transmissions also follow this offset. See Figure 5 for an example of using TBOF. |

Functional Description (continued)**Table 17. Register R10—Transmitter Time-Slot Offset Control Register**

| R10—B7 | R10—B6 | R10—B5 | R10—B4 | R10—B3 | R10—B2 | R10—B1 | R10—B0 |
|------------|--------------|---------------|---------------|---------------|---------------|---------------|---------------|
| DXI (0) | TLBIT (1) | TTSOF5 (0) | TTSOF4 (0) | TTSOF3 (0) | TTSOF2 (0) | TTSOF1 (0) | TTSOF0 (0) |

| Register | Bit | Symbol | Name/Function |
|----------|--------|---------------|--|
| R10 | B(0—5) | TTSOF0—TTSOF5 | Transmitter Time-Slot Offset. The value of these 6 bits, coded in binary with bit 0 being the LSB, specifies the number of time slots to delay between the beginning of the first locatable time slot and the beginning of a new virtual TDM frame (i.e., the time slot defined by the user as time slot 0). See Figure 5 for an example of using the TTSOF bits. |
| R10 | B6 | TLBIT | Transmit Least Significant Bit First. This bit is used to control whether the least significant or most significant data bit is transmitted first. The least significant bit of transmit data is defined as the transmit FIFO data bit written by the host on the AD0 pin. When TLBIT is 0, the most significant bit of data is transmitted first, and when TLBIT is set to 1, the least significant bit of data is transmitted first. TLBIT has no meaning when not in the TDM highway mode (i.e., HWYEN, R0—B7 = 0). Data in non-TDM highway mode is always least significant bit first. |
| R10 | B7 | DXI | Transmit Data Inverted. If this bit is set to 1, the serial data output is inverted before transmission. |

Functional Description (continued)

Table 18. Register R11—Receiver Time-Slot Offset Control Register

| R11—B7 | R11—B6 | R11—B5 | R11—B4 | R11—B3 | R11—B2 | R11—B1 | R11—B0 |
|------------|--------------|---------------|---------------|---------------|---------------|---------------|---------------|
| DRI (0) | RLBIT (1) | RTSOF5 (0) | RTSOF4 (0) | RTSOF3 (0) | RTSOF2 (0) | RTSOF1 (0) | RTSOF0 (0) |

| Register | Bit | Symbol | Name/Function |
|----------|--------|---------------|--|
| R11 | B(0—5) | RTSOF0—RTSOF5 | Receiver Time-Slot Offset. The value of these 6 bits, coded in binary with bit 0 being the LSB, specifies the number of time slots to delay between the beginning of the first locatable TDM highway time slot and the beginning of a new virtual TDM frame (i.e., the time slot defined by the user as time slot 0.) See Figure 5 for an example of using the RTSOF bits. |
| R11 | B6 | RLBIT | Receive Least Significant Bit First. This bit is used to control whether the least significant or most significant data bit is received first. The least significant data bit in the receive FIFO is defined as that bit which is read on AD0 when the FIFO is read. When RLBIT is 0, the most significant bit of data is received first, and when RLBIT is set to 1, the least significant bit of data is received first. RLBIT has no meaning when not in the TDM highway mode (i.e., HWYEN, R0—B7 = 0). In non-TDM highway mode, data is always received least significant bit first. |
| R11 | B7 | DRI | Receive Data Inverted. If this bit is set to 1, the serial data input to the DRA (or DRB) pin is inverted before data is passed to the HDLC receiver (or FIFO in the transparent mode). |

Functional Description (continued)**Table 19. Alternate Register AR11—Transparent-Mode Control Register**

| AR11—B7 | AR11—B6 | AR11—B5 | AR11—B4 | AR11—B3 | AR11—B2 | AR11—B1 | AR11—B0 |
|-------------|--------------|--------------|--------------|--------------|---------------|---------------|---------------|
| TEST (0) | TRANS (0) | MATCH (0) | ALOCT (0) | MSTAT (0) | OCTOF2 (0) | OCTOF1 (0) | OCTOF0 (0) |

| Register | Bit | Symbol | Name/Function |
|----------|--------|---------------|--|
| AR11 | B(0—2) | OCTOF0—OCTOF2 | Octet Bit Offset. Read only. These bits record the offset relative to the octet boundary* when the receive character was matched. The OCTOF bits are valid when MSTAT (AR11—B3) is set to 1. These bits indicate one less than the actual offset; i.e., no offset is 111 (byte alignment), one bit of offset is 000, etc. |
| AR11 | B3 | MSTAT | Match Status. Read only. When this bit is set to 1, the receiver match character has been recognized. The octet offset status bits (AR11—B[0—2]) indicate the offset relative to the octet boundary* at which the receive character was matched. If no match is being performed (MATCH AR11—B5 = 0), the MSTAT bit is set to 1 automatically when the first bit is received, and the octet offset status bits (AR11—B[0—2]) read 000. |
| AR11 | B4 | ALOCT | Frame-Sync Align. When this bit is set to 1, the HIFI-64 searches for the receive match character (AR12) only on an octet boundary. When this bit is 0, the HIFI-64 searches for the receive match character in a sliding window fashion. See Table 5. |
| AR11 | B5 | MATCH | Pattern Match. MATCH affects both the transmitter and receiver. When this bit is set to 1, the HIFI-64 does not load data into the receive FIFO until the receive match character programmed in AR12 has been detected. The search for the receive match character is in a sliding window fashion if the ALOCT bit (AR11—B4) is 0, or only on octet boundaries* if the ALOCT bit (AR11—B4) is set to 1. When this bit is 0, the HIFI-64 loads the matched byte and all subsequent data directly into the receive FIFO. See Table 5. On the transmit side, when this bit is set to 1, the transmitter sends the transmit idle character programmed into AR13 when the transmit FIFO has no user data. The default idle is to transmit the HDLC 1s idle character (FF hexadecimal); however, any value can be used by programming the transmit idle character register (AR13). If this bit is 0, the transmitter sends 1s idle characters when the transmit FIFO is empty. |
| AR11 | B6 | TRANS | Transparent Mode. When this bit is set to 1, the HIFI-64 performs no HDLC processing on incoming or outgoing data. |
| AR11 | B7 | TEST | TEST. This bit is reserved for manufacturing test purposes only. Program to 0. |

* The octet boundary is relative to the time-slot boundary if HWYEN (R0—B7) = 1, or relative to the first receive clock edge after the receiver has been enabled (ENR, R6—B2 = 1) if HWYEN = 0.

Functional Description (continued)

Table 20. Register R12—Receiver Mask Register

| R12—B7 | R12—B6 | R12—B5 | R12—B4 | R12—B3 | R12—B2 | R12—B1 | R12—B0 |
|-------------|-------------|-------------|-------------|-------------|-------------|-------------|-------------|
| RBM7 (1) | RBM6 (1) | RBM5 (1) | RBM4 (1) | RBM3 (1) | RBM2 (1) | RBM1 (1) | RBM0 (1) |

| Register | Bit | Symbol | Name/Function |
|----------|--------|-----------|---|
| R12 | B(0—7) | RBM0—RBM7 | <p>Receiver Time-Slot Bit Mask. This register allows the HIFI-64 to process some subset of each byte received. A 1 in each bit position means the whole byte is valid data, while placing a 0 in any bit position instructs the HIFI-64 to ignore that bit. For example, 11111111 (default) means process the entire received byte, and 11000000 means process only the two most significant bits.</p> <p>The masking feature is available only in the TDM highway mode (i.e., HWYEN, R0—B7 = 1). RBM0 masks the least significant bit received (as defined by RLBIT [R11—B6]). See Figures 8 and 9 for examples of bit masking and subrate operation.</p> |

Table 21. Alternate Register AR12—Receiver Match Character Register

| AR12—B7 | AR12—B6 | AR12—B5 | AR12—B4 | AR12—B3 | AR12—B2 | AR12—B1 | AR12—B0 |
|-------------|-------------|-------------|-------------|-------------|-------------|-------------|-------------|
| RMC7 (0) | RMC6 (1) | RMC5 (1) | RMC4 (1) | RMC3 (1) | RMC2 (1) | RMC1 (1) | RMC0 (0) |

| Register | Bit | Symbol | Name/Function |
|----------|--------|-----------|--|
| AR12 | B(0—7) | RMC0—RMC7 | <p>Receiver Match Character. This character is used only in transparent mode (TRANS, AR11—B6 = 1). When the pattern match bit (MATCH, AR11—B5) is set to 1, the HIFI-64 searches the incoming bit stream for the receiver match character. Data is loaded into the receive FIFO only after this character has been identified. The bits identified as matching the receiver match character are the first byte loaded into the receive FIFO. The default is to search for a flag, but any character can be programmed by the user. The search for the receiver match character can be in a sliding window fashion (ALOCT, AR11—B4 = 0) or only on byte boundaries (ALOCT, AR11—B4 = 1).</p> |

Functional Description (continued)**Table 22. Register R13—Transmitter Mask Register**

| R13—B7 | R13—B6 | R13—B5 | R13—B4 | R13—B3 | R13—B2 | R13—B1 | R13—B0 |
|-------------|-------------|-------------|-------------|-------------|-------------|-------------|-------------|
| TBM7 (0) | TBM6 (0) | TBM5 (0) | TBM4 (0) | TBM3 (0) | TBM2 (0) | TBM1 (0) | TBM0 (0) |

| Register | Bit | Symbol | Name/Function |
|----------|--------|-----------|--|
| R13 | B(0—7) | TBM0—TBM7 | <p>Transmitter Time-Slot Bit Mask. This register allows the HIFI-64 to transmit some subset of each byte during a time slot. A 1 in each bit position instructs the HIFI-64 to send valid data during each bit time when it is the HIFI-64's turn on the highway. Placing a 0 in any bit position instructs the HIFI-64 to 3-state the transmit pin(s) during that bit time. For example, 00000000 (default) means 3-state during the entire time slot, 11000000 means transmit the two most significant bits during each time slot, and 11111111 transmits the entire byte. See Figures 8 and 9 for examples of bit masking and subrate operation.</p> <p>Default is all 0s so that the HIFI-64 does not transmit on the bus before a time slot has been assigned. The masking feature is available only in the TDM highway mode (i.e., HWYEN, R0—B7 = 1). TBM0 masks the least significant bit transmitted (as defined by TLBIT, R10—B6).</p> |

Table 23. Alternate Register AR13—Transmitter Idle Character Register

| AR13—B7 | AR13—B6 | AR13—B5 | AR13—B4 | AR13—B3 | AR13—B2 | AR13—B1 | AR13—B0 |
|-------------|-------------|-------------|-------------|-------------|-------------|-------------|-------------|
| TIC7 (1) | TIC6 (1) | TIC5 (1) | TIC4 (1) | TIC3 (1) | TIC2 (1) | TIC1 (1) | TIC0 (1) |

| Register | Bit | Symbol | Name/Function |
|----------|--------|-----------|--|
| AR13 | B(0—7) | TIC0—TIC7 | <p>Transmitter Idle Character. This character is used only in transparent mode (TRANS, R11—B6 = 1). When the pattern match bit (MATCH, AR11—B5) is set to 1, the HIFI-64 transmits this character whenever the transmit FIFO is empty. The default is to send the 1s idle character, but any character can be programmed by the user.</p> |

Functional Description (continued)

Table 24. Register R14—Interrupt Mask Register

| R14—B7 | R14—B6 | R14—B5 | R14—B4 | R14—B3 | R14—B2 | R14—B1 | R14—B0 |
|--------------|-------------|--------------|---------------|-------------|--------------|-------------|-------------|
| TBCRC (0) | RIIE (0) | ROVIE (0) | REOFIE (0) | RFIE (0) | UNDIE (0) | TEIE (0) | TDIE (0) |

| Register | Bit | Symbol | Name/Function |
|----------|-----|--------|--|
| R14 | B0 | TDIE | Transmit-Done Interrupt Enable. When this interrupt enable bit is set, an INT pin transition* is generated after the last bit of the closing flag or abort sequence is sent. In the transparent mode (TRANS, AR11—B6 = 1), an INT pin transition is generated when the transmit FIFO is completely empty. TDIE is cleared upon reset. |
| R14 | B1 | TEIE | Transmitter-Empty Interrupt Enable. When this interrupt-enable bit is set, an INT pin transition is generated when the transmit FIFO has reached the programmed empty level (see Register 1). TEIE is cleared upon reset. |
| R14 | B2 | UNDIE | Underrun Interrupt Enable. When this interrupt-enable bit is set, an INT pin transition is generated when the transmit FIFO has underrun. UNDIE is cleared upon reset. UNDIE is not used in transparent mode. |
| R14 | B3 | RFIE | Receiver-Full Interrupt Enable. When this interrupt-enable bit is set, an INT pin transition is generated when the receive FIFO has reached the programmed full level (see Register 5). RFIE is cleared upon reset. |
| R14 | B4 | REOFIE | Receive End-of-Frame Interrupt Enable. When this interrupt-enable bit is set, an INT pin transition is generated when an end-of-frame is detected by the HDLC receiver. REOFIE is cleared upon reset. REOFIE is not used in transparent mode. |
| R14 | B5 | ROVIE | Receiver Overrun Interrupt Enable. When this interrupt-enable bit is set, an INT pin transition is generated when the receive FIFO overruns. ROVIE is cleared upon reset. |
| R14 | B6 | RIIE | Receiver Idle-Interrupt Enable. When this interrupt-enable bit is set, an INT pin transition is generated when the receiver enters the idle state. RIIE is cleared upon reset. RIIE is not used in transparent mode. |
| R14 | B7 | TBCRC | Transmit Bad CRC. Setting this bit to 1 forces bad CRCs to be sent on all transmitted frames (for test purposes) until the TBCRC bit is cleared to 0. |

* The first occurrence of an unmasked interrupt causes the INT pin to transition. The INT pin remains active until the interrupt is acknowledged by a read of register 15. Additional unmasked interrupts occurring before the read of register 15 do **not** cause a new transition of the INT pin, but are reported in register 15 when it is read.

Functional Description (continued)**Table 25. Register R15—Interrupt Status Register**

| R15—B7 | R15—B6 | R15—B5 | R15—B4 | R15—B3 | R15—B2 | R15—B1 | R15—B0 |
|----------|-------------|---------------|-------------|-----------|---------------|-----------|---------------|
| 0 (-) | RIDL (0) | OVERUN (0) | REOF (0) | RF (0) | UNDABT (0) | TE (1) | TDONE (0)* |

| Register | Bit | Symbol | Name/Function |
|----------|-----|----------|--|
| R15 | B0 | TDONE | Transmit Done. This status bit is set to 1 when transmission of the current HDLC frame has been completed, either after the last bit of the closing flag or after the last bit of an abort sequence. In the transparent mode (AR11—B6 = 1), this status bit is set when the transmit FIFO is completely empty. A hardware interrupt is generated only if the corresponding interrupt-enable bit (R14—B0) is set. This status bit is cleared to 0 by a read of register 15. |
| R15 | B1 | TE | Transmitter Empty. If this bit is set to 1, the HDLC transmit FIFO is at or below the programmed depth (see register 1). A hardware interrupt is generated only if the corresponding interrupt-enable bit (R14—B1) is set. If DINT (R0—B0) is 0, this status bit is cleared by a read of register 15. If DINT (R0—B0) is set to 1, this bit actually represents the dynamic transmit empty condition, and is cleared to 0 only when the transmit FIFO is loaded above the programmed empty level. |
| R15 | B2 | UNDABT | Underrun Abort. A 1 indicates that an abort was transmitted because of a transmit FIFO underrun. A hardware interrupt is generated only if the corresponding interrupt-enable bit (R14—B2) is set. This status bit is cleared to 0 by a read of register 15. This bit must be cleared to 0 before further transmission of data is allowed. This interrupt is not generated in transparent mode. |
| R15 | B3 | RF | Receiver Full. This bit is set to 1 when the receive FIFO is at or above the programmed full level (see register 5). A hardware interrupt is generated if the corresponding interrupt-enable bit (R14—B3) is set. If DINT (R0—B0) is 0, this status bit is cleared to 0 by a read of register 15. If DINT (R0—B0) is set to 1, then this bit actually represents the dynamic receive-full condition and is cleared only when the receive FIFO is read (or emptied) below the programmed full level. |
| R15 | B4 | EOF | Receive End-of-Frame. This bit is set to 1 when the receiver has finished receiving a frame. It becomes 1 upon reception of the last bit of the closing flag of a frame or the last bit of an abort sequence. A hardware interrupt is generated only if the corresponding interrupt-enable bit (R14—B4) is set. This status bit is cleared to 0 by a read of register 15. This bit is not generated in transparent mode. |
| R15 | B5 | OVERUN | Receiver Overrun. This bit is set to 1 when the receive FIFO has overrun its capacity. A hardware interrupt is generated only if the corresponding interrupt-enable bit (R14—B5) is set. This status bit is cleared to 0 by a read of register 15. |
| R15 | B6 | RIDL | Receiver Idle. This bit is set to 1 when the HIFI-64 HDLC receiver is idle (i.e., 15 or more consecutive 1s have been received). A hardware interrupt is generated only if the corresponding interrupt-enable bit (R14—B6) is set. This status bit is cleared to 0 by a read of register 15. |
| R15 | B7 | RESERVED | Program to 0. |

* In transparent mode (TRANS, AR11—B6 = 1), TDONE defaults to 1 when a transmitter reset (TRES, R6—B5 = 1) is performed.

Absolute Maximum Ratings

Stresses in excess of the absolute maximum ratings can cause permanent damage to the device. These are absolute stress ratings only. Functional operation of the device is not implied at these or any other conditions in excess of those given in the operational sections of the data sheet. Exposure to absolute maximum ratings for extended periods can adversely affect device reliability.

| Parameter | Symbol | Min | Max | Unit |
|-----------------------------------|--------|-----------|-----------|------|
| dc Supply Voltage Relative to VSS | VDD | — | 7 | V |
| Input Voltage Range | Vi | VSS – 0.5 | VDD + 0.5 | V |
| Storage Temperature Range | Tstg | –40 | 125 | °C |

Electrical Characteristics

TA = 0 °C to 70 °C, or –40 °C to +85 °C (see Ordering Information). VDD = 5 V ± 5%, VSS = 0 V, 100 pF each output.

| Parameter | Symbol | Test Conditions | Min | Max | Unit |
|--|--------|--|-----|-------|------|
| Supply Current | IDD | TA = 70 °C | — | 15 | mA |
| Input Leakage Current: High Level (logic 1) | IiH | VIH = 5.25 V | — | –7.5 | A |
| Low Level (logic 0) | IiL | VIL = 0 V (except A3—A0) | — | 7.5 | μA |
| Low Level (logic 0) | ILA | VIL = 0, A3—A0 | — | 60 | μA |
| Input Leakage Current Bidirectional Pins: High Level (logic 1) | IiH | VIH = 5.25 V | — | –37.5 | μA |
| Low Level (logic 0) | IiL | VIL = 0 V | — | 37.5 | μA |
| Output 3-state Leakage Current: High Level (logic 1) | IOZH | VOH = 5.25 V | — | –30 | μA |
| Low Level (logic 0) | IOZL | VOL = 0 V | — | 30 | μA |
| Input Voltage: High Level (logic 1) | VIH | — | 2.0 | — | — |
| Low Level (logic 0) | VIL | — | — | 0.8 | V |
| Output Voltage: High Level (logic 1) | VOH | IOH = –2.4 mA | 2.4 | — | V |
| High Level (CMOS 1) | VOHC | IOHC = –0.24 mA | 3.5 | — | V |
| Low Level (logic 0) | VOL | IOL = 2.4 mA | — | 0.4 | V |
| Power Dissipation (nominal 30 mW) | PD | CLK = 12 MHz, CLKX = CLKR = 4.096 MHz TA = 70 °C | — | 80 | mW |
| | | TA = 0 °C | — | 105 | mW |
| | | TA = –40 °C | — | 120 | mW |
| Powerdown Mode (nominal 5 mW) | PD | CLK = 12 MHz, CLKX = CLKR = 4.096 MHz | — | 15 | mW |
| Input Capacitance | Ci | — | — | 4 | pF |
| Output Capacitance | Co | — | — | 5 | pF |

Clock Characteristics

System Clock Input (CLK): 0 MHz—12 MHz.

Transmit Data Clock (CLKX): no minimum frequency*, $\lt; \text{CLK}/2$ maximum frequency to 4.096 MHz.

Receive Data Clock (CLKR): no minimum frequency*, $\lt; \text{CLK}/2$ maximum frequency to 4.096 MHz.

* 8.192 MHz in CMS mode (R8—B6 = 1).

Timing Characteristics

TDM Frame Timing Diagrams

The timing of the transmission or reception of the first bit relative to the frame-sync pulse depends on the configuration of 3 bits: FE (R0—B5), CLKXI (R9—B4), CLKRI (R9—B0). The timing diagrams below illustrate different configurations of FE, CLKXI, and CLKRI.

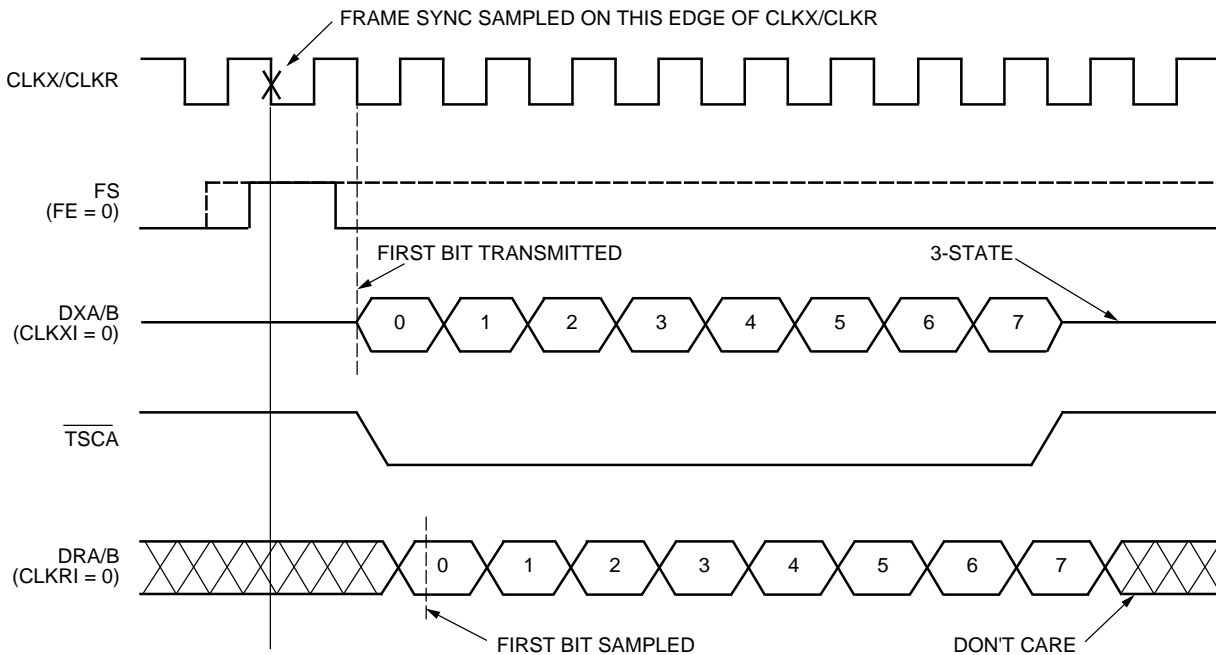

5-5038

Figure 12. FE = 0, CLKXI = 0, CLKRI = 0

Timing Characteristics (continued)

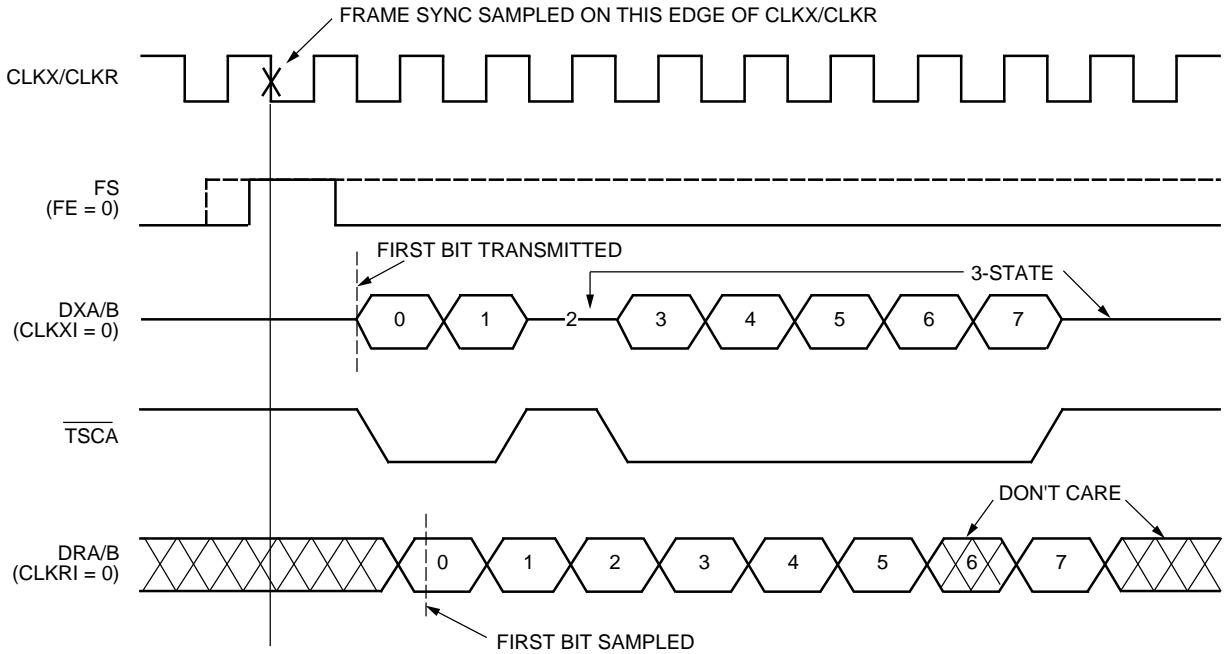

5-5039

Figure 13. Bit Masking, Bit 2 Masked for Transmit, Bit 6 Masked for Receive

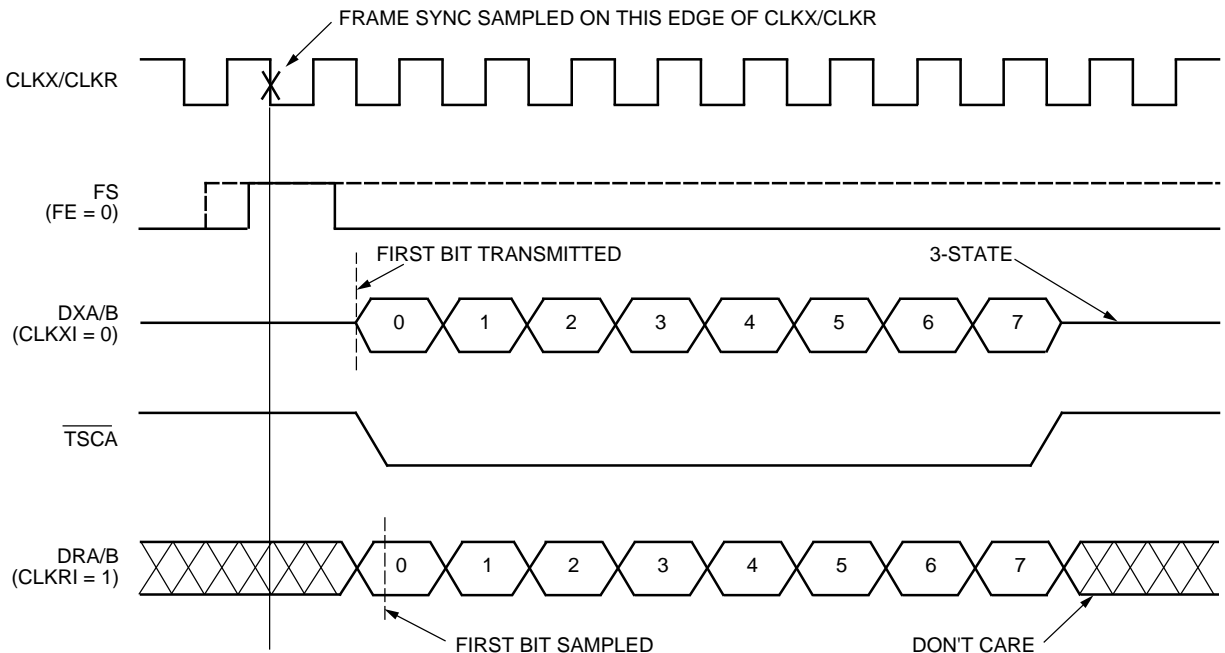

5-5040

Figure 14. FE = 0, CLKXI = 0, CLKRI = 1

Timing Characteristics (continued)

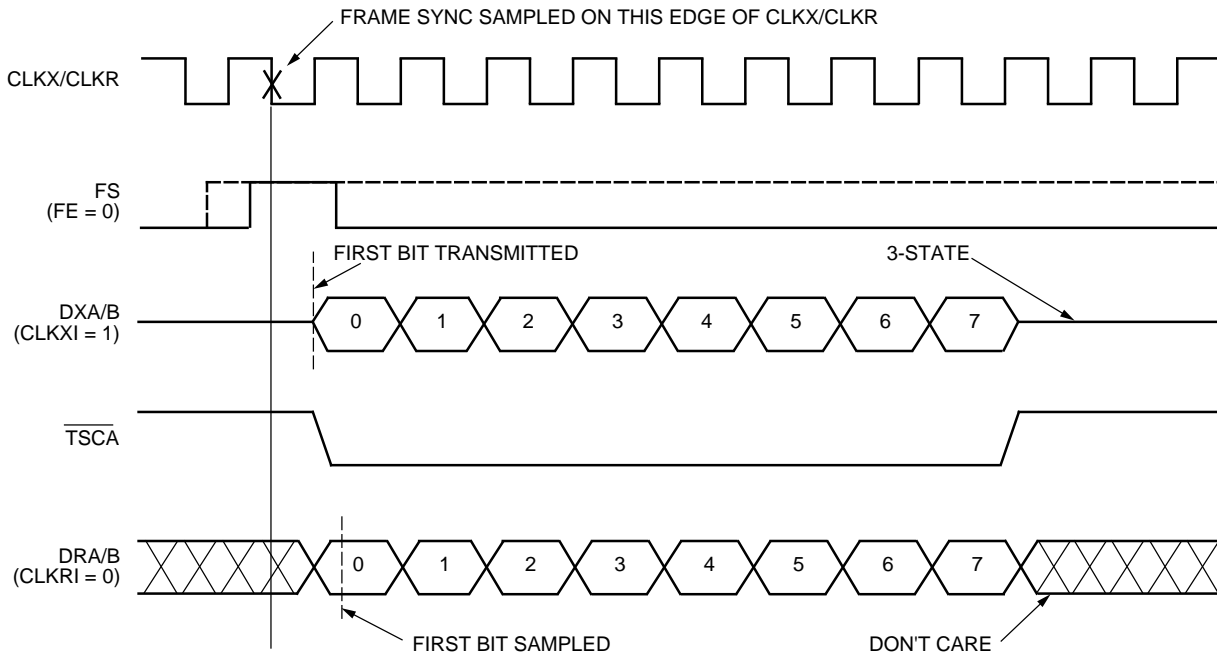

5-5041

Figure 15. FE = 0, CLKXI = 1, CLKRI = 0

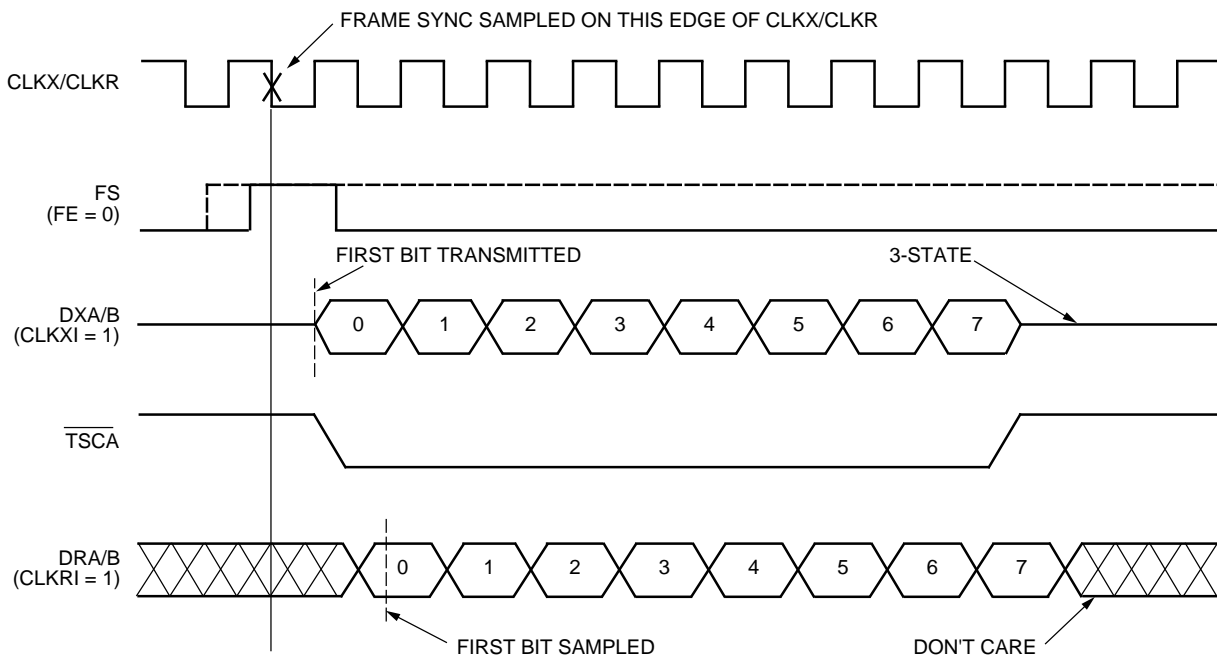

5-5042

Figure 16. FE = 0, CLKXI = 1, CLKRI = 1

Timing Characteristics (continued)

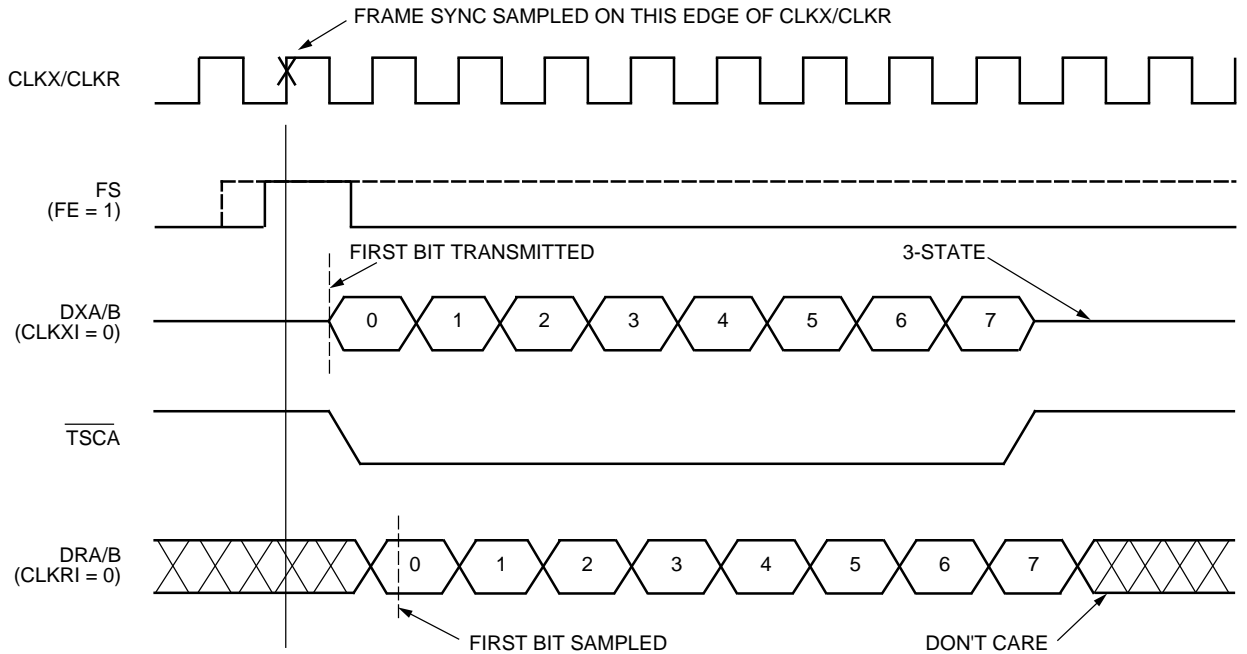

5-5043

Figure 17. FE = 1, CLKXI = 0, CLKRI = 0

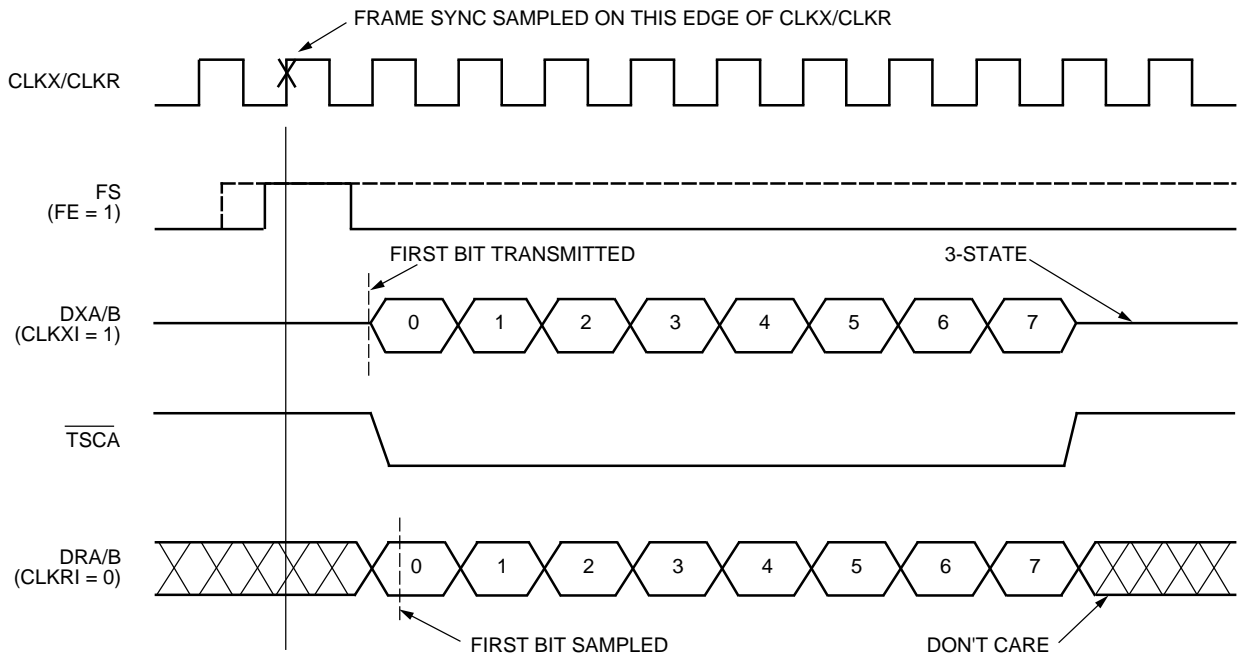

5-5044

Figure 18. FE = 1, CLKXI = 1, CLKRI = 0

Timing Characteristics (continued)

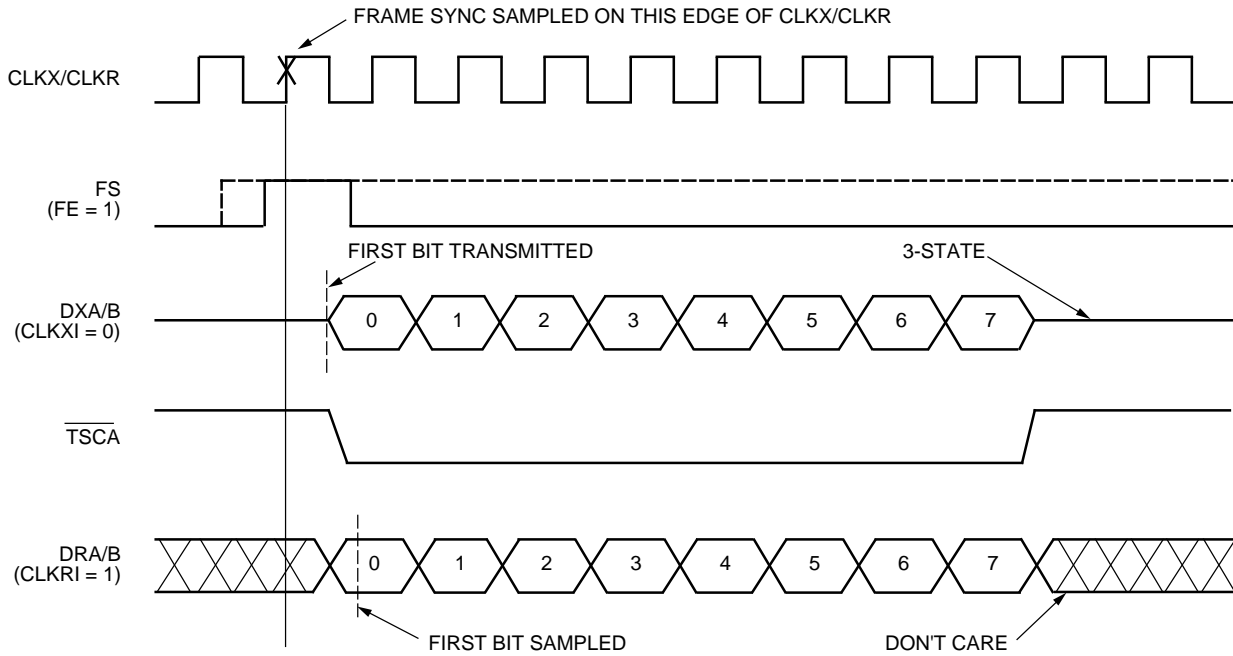

5-5045

Figure 19. FE = 1, CLKXI = 0, CLKRI = 1

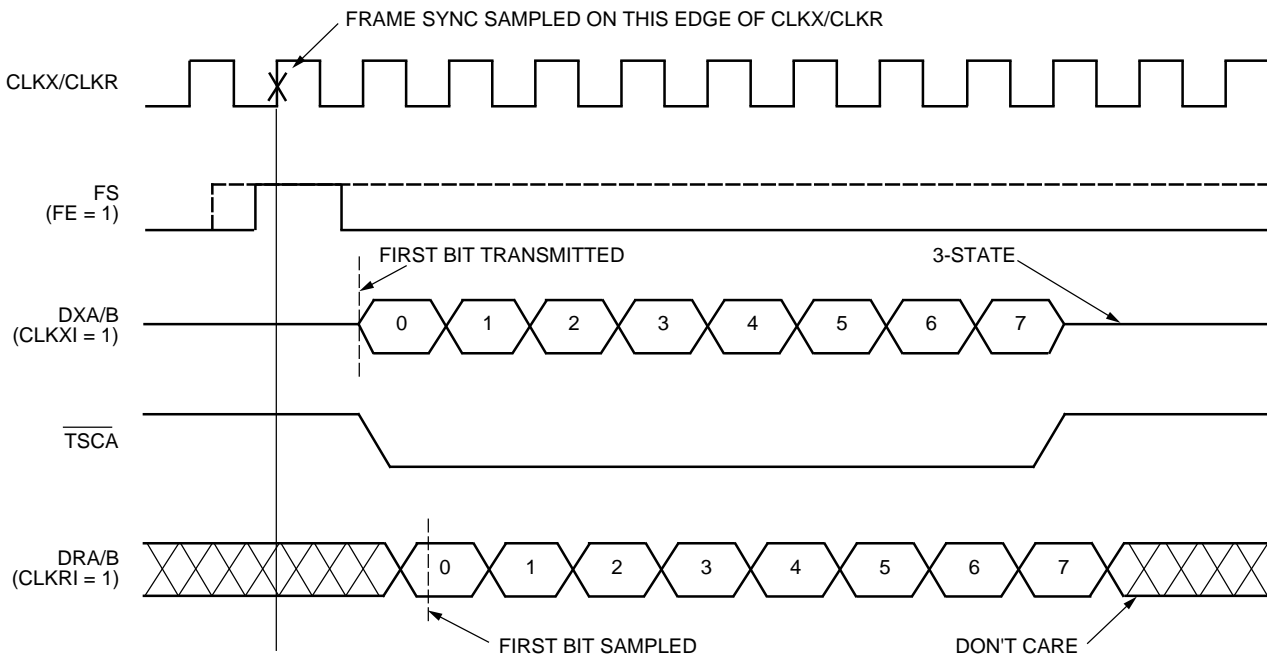

5-5046

Figure 20. FE = 1, CLKXI = 1, CLKRI = 1

Timing Characteristics (continued)

Multiplexed Address and Data

Both address and data on AD7—AD0.

Table 26. Multiplexed Address and Data

| Symbol on Diagram | Name | Parameter | Min | Max | Unit |
|-------------------|---------|--|--------------|-------------------------|------|
| A | tALHALL | ALE Pulse Width | 25 | 3 tMCLMCL | ns |
| B | tADVALL | Address Valid to ALE Low | 25 | — | ns |
| C | tADHALL | Address Hold After ALE Low | 0 | — | ns |
| D | tALLRWL | ALE Low to \overline{RD} or \overline{WR} Low | 35 | — | ns |
| E | tCSLRWL | \overline{CS} Low to \overline{RD} or \overline{WR} Low | 0 | — | ns |
| F | tDVWRH | Data Valid to \overline{WR} High | 35 | — | ns |
| G | tWRHDI | Data Hold After \overline{WR} High | 10 | — | ns |
| H | tWRLWRH | \overline{WR} Pulse Width | 40 | — | ns |
| I | tRDLRDH | \overline{RD} Pulse Width | tMCLMCL + 40 | — | ns |
| J | tRDLDV | \overline{RD} Low to Data Valid (R2 or R4) \overline{RD} Low to Data Valid (all others) | — | tMCLMCL + 40 tMCLMCL | ns |
| K | tRDHDI | \overline{RD} High to Data 3-state | — | 25 | ns |
| L | tWRHCSH | \overline{WR} High to \overline{CS} High | 0 | — | ns |
| M | tRDHCSH | \overline{RD} High to \overline{CS} High | 10 | — | ns |
| N | tWRHWRL | \overline{WR} High to \overline{WR} Low (minimum time between writes) | 2 tMCLMCL | — | ns |
| O | tRDHRDL | \overline{RD} High to \overline{RD} Low (minimum time between reads); Read R3 to Read R4* | 4 tMCLMCL | — | ns |
| P | tMCLMCL | Master Clock Period† | 83.3 | <tDCLDCL | ns |

* This is the time needed to update the receive FIFO status RQS (R4—B[6—0]).

† See Figure 24 for data clock period specification.

Timing Characteristics (continued)

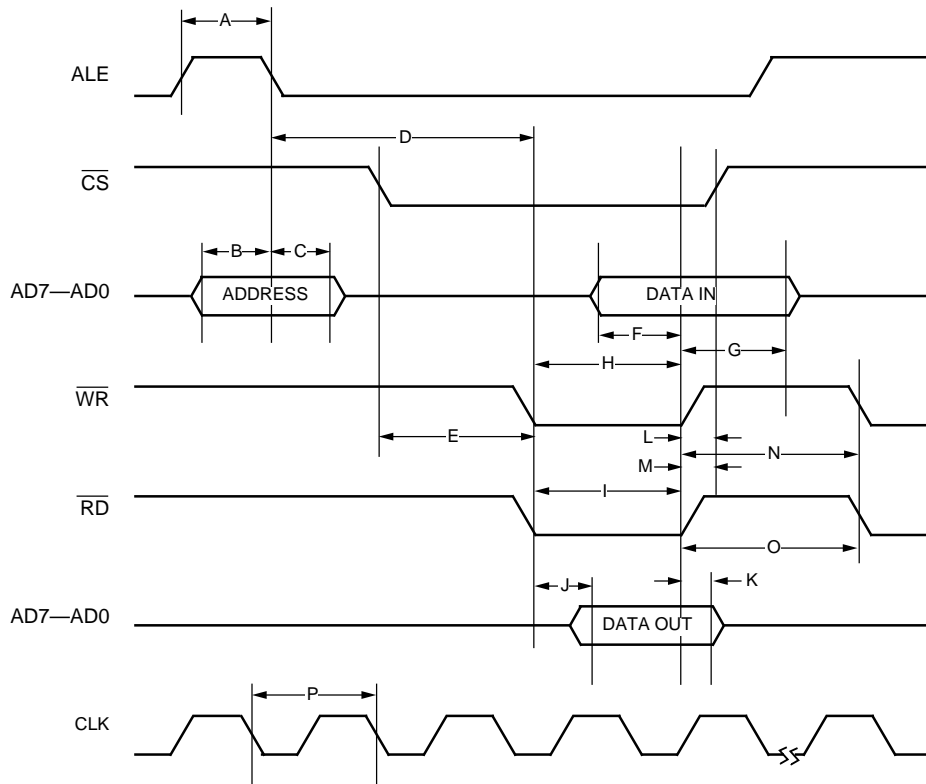

5-5047

Figure 21. Timing for Multiplexed Address/Data

Timing Characteristics (continued)

Separate Address and Data

Address on A3—A0, data on AD7—AD0.

Table 27. Separate Address and Data

| Symbol on Diagram | Name | Parameter | Min | Max | Unit |
|-------------------|---------|---|-------------|-------------------------|----------|
| A | tALHCSL | ALE High to \overline{CS} Low* | 5 tMCLMCL | — | ns |
| B | tRWHALL | \overline{RD} or \overline{WR} High to ALE Low* | 1/2 tMCLMCL | — | ns |
| C | tAVRDL | Address Valid to \overline{RD} or \overline{WR} Low* | 35 | — | ns |
| D | tWRHAI | Address Hold After \overline{WR} High | 20 | — | ns |
| E | tRDHAI | Address Hold After \overline{RD} High | 0 | — | ns |
| F | tDVWRH | Data Valid to \overline{WR} High | 35 | — | ns |
| G | tWRHDI | Data Hold After \overline{WR} High | 10 | — | ns |
| H | tCSLRWL | \overline{CS} Low to \overline{RD} or \overline{WR} Low | 0 | — | ns |
| I | tWRLWRH | \overline{WR} Pulse Width | 40 | — | ns |
| J | tRDLDV | \overline{RD} Low to Data Valid (register 2 or 4) \overline{RD} Low to Data Valid (all others) | — | tMCLMCL + 40 tMCLMCL | ns ns |
| K | tRDHDI | \overline{RD} High to Data 3-state | — | 25 | ns |
| L | tRDLRDH | \overline{RD} Pulse Width | tMCLMCL 40 | — | ns |
| M | tWRHCSH | \overline{WR} High to \overline{CS} High | 0 | — | ns |
| N | tRDHCSH | \overline{RD} High to \overline{CS} High | 10 | — | ns |
| O | tMCLMCL | Master Clock Period | 83.3 | <1/2 tDCLDCL | ns |
| P | tWRHWRL | \overline{WR} High to \overline{WR} Low (minimum time between writes) | 2 tMCLMCL | — | ns |
| Q | tRDHRDL | \overline{RD} High to \overline{RD} Low (minimum time between reads); Read R3 to Read R4† | 4 tMCLMCL | — | ns |

* It is recommended that ALE be tied high when separate address and data bits are used. If ALE is pulled low, the T7121 enters multiplexed address and data mode. ALE must then be held high for five master clock cycles, to switch back to separate address and data mode. ALE must remain high during read and write operations.

† This is the time needed to update the receive FIFO status RQS (R4 B[6—0]).

Timing Characteristics (continued)

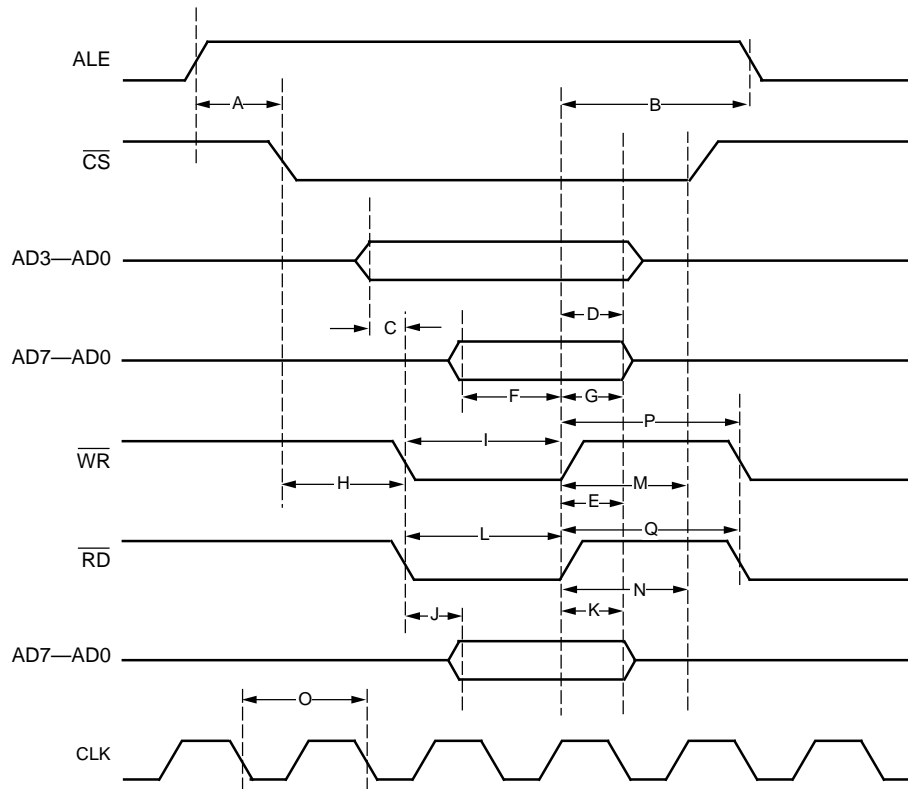

5-5048

Figure 22. Timing for Separate Address/Data

Timing Characteristics (continued)

Concentration Highway

Table 28. Concentration Highway Timing for CMS = 0

| Symbol on Diagram | Name | Parameter | Min | Max | Unit |
|-------------------|---------|--|-----------|--------------|------|
| A | tDCLDCL | CLKX/R Period | 244 | — | ns |
| B | tFSHCKE | FS High to CLKX/R Edge Selected | 50 | tDCLDCL – 30 | ns |
| C | tCKEFSL | FS Hold After CLKX/R Edge Selected | 50 | — | ns |
| D | tCEDV | CLKX Edge to Data Valid | — | 80 | ns |
| E | tCEDT | CLKX Edge to Data 3-state | 0 | 45 | ns |
| F | tCETSL | CLKX Edge to \overline{TSCA} Low | — | 70 | ns |
| G | tCETST | CLKX Edge to \overline{TSCA} 3-state | 0 | 70 | ns |
| H | tDVRCE | Receive Data Setup Time | 25 | — | ns |
| I | tRCEDI | Receive Data Hold Time | 20 | — | ns |
| J | tFSFS | FS Period | 9 tDCLDCL | 512 tDCLDCL | ns |

Timing Characteristics (continued)

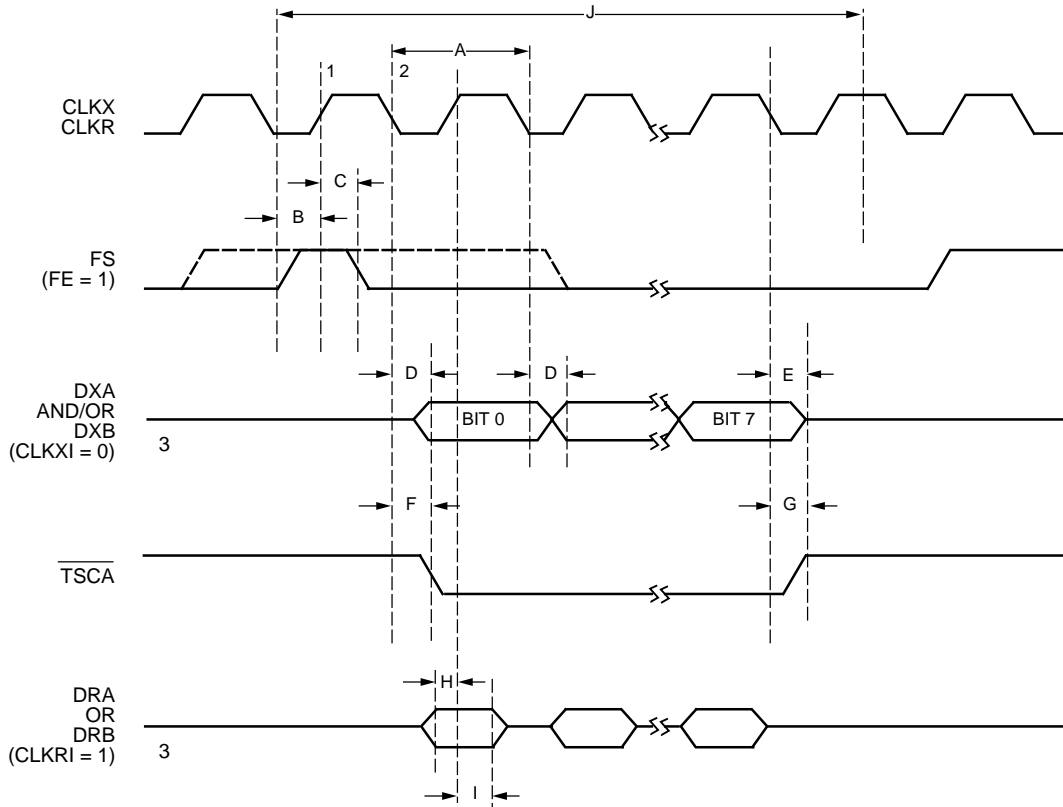

(CMS = 0, CLKXI = 0, CLKRI = 1, FSPOL = 1, RBM = TBM = 11111111)

5-5049

1. Edge of clock used to sample FS (selected by the FE bit [R0—B6]).
2. Edge of first bit transmission (see Figures 12—20).
3. The CLKXI bit (R9—B4) controls the edge on which data is transmitted, and the CLKRI bit (R9—B0) controls the edge on which received data is sampled.

Figure 23. Timing for Concentration Highway

Timing Characteristics (continued)

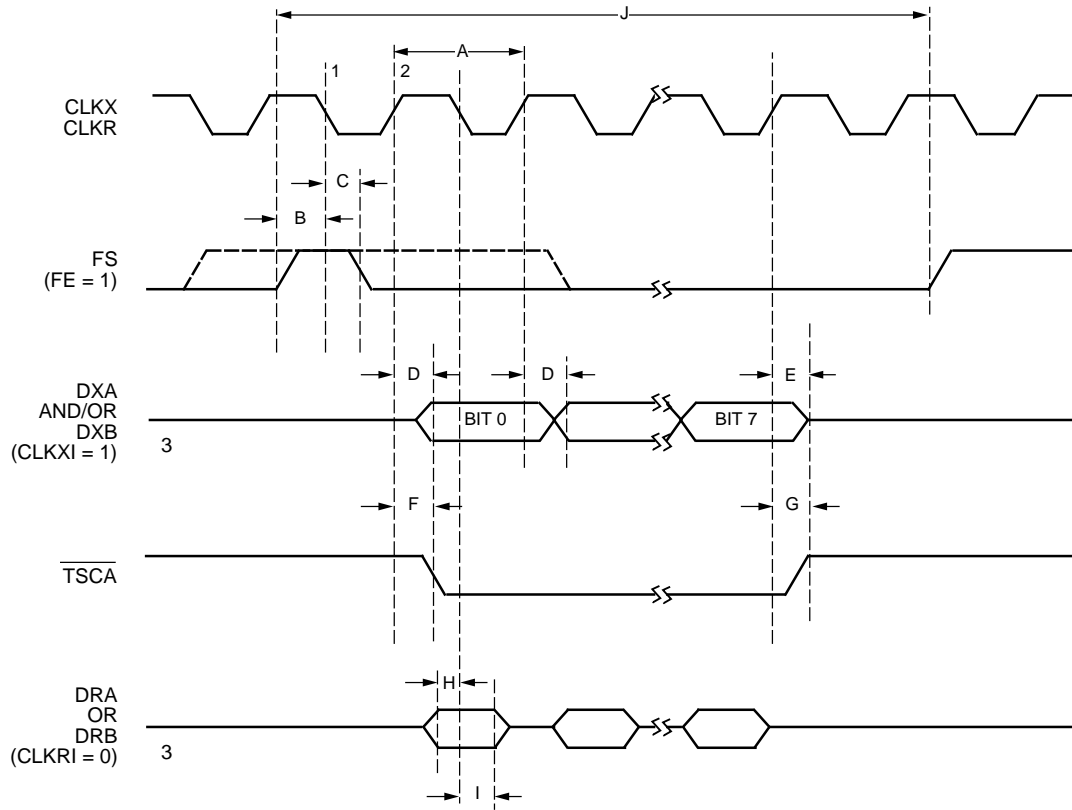

(CMS = 0, CLKXI = 1, CLKRI = 0, FSPOL = 1, RMB = TBM = 11111111)

5-5050

1. Edge of clock used to sample FS (selected by the FE bit [R0—B6]).
2. Edge of first bit transmission (see Figures 12—20).
3. The CLKXI bit (R9—B4) controls the edge on which data is transmitted, and the CLKRI bit (R9—B0) controls the edge on which received data is sampled.

Figure 24. Timing for Concentration Highway

Timing Characteristics (continued)

Table 29. Concentration Highway Timing for CMS = 1

| Symbol on Diagram | Name | Parameter | Min | Max | Unit |
|-------------------|---------|------------------------------------|------------|--------------|------|
| A | tDCLDCL | CLKX/R Period | 122 | — | ns |
| B | tFSHCKE | FS High to CLKX/R Edge Selected | 50 | tDCLDCL - 30 | ns |
| C | tCKEFSL | FS Hold After CLKX/R Edge Selected | 50 | — | ns |
| D | tCEDV | CLKX Edge to Data Valid | — | 80 | ns |
| E | tCEDT | CLKX Edge to Data 3-state | 0 | 45 | ns |
| F | tCETSL | CLKX Edge to TSCA Low | — | 70 | ns |
| G | tCETST | CLKX Edge to TSCA 3-state | 0 | 70 | ns |
| H | tDVRCE | Receive Data Setup Time | 25 | — | ns |
| I | tRCEDI | Receive Data Hold Time | 20 | — | ns |
| J | tFSFS | FS Period | 18 tDCLDCL | 1024 tDCLDCL | ns |

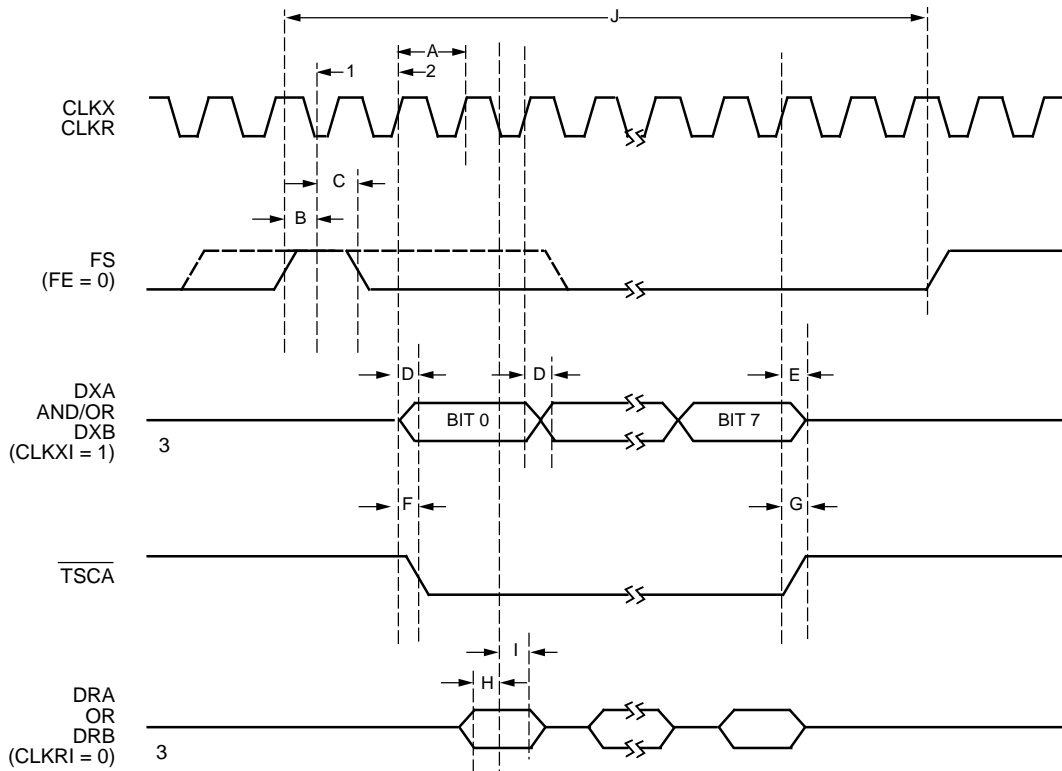

(CMS = 1, CLKXI = 1, CLKRI = 0, FSPOL = 1, RMB = TBM = 11111111)

5-5051

1. Edge of clock used to sample FS (selected by the FE bit [R0—B6]).
2. Edge of first bit transmission (see Figures 12—20).
3. The CLKXI bit (R9—B4) controls the edge on which data is transmitted, and the CLKRI bit (R9—B0) controls the edge on which received data is sampled.

Figure 25. Timing for Concentration Highway

Handling Precautions

Although protection circuitry has been designed into this device, proper precautions should be taken to avoid exposure to electrostatic discharge (ESD) during handling and mounting. Lucent employs a human-body model (HBM) and a charged-device model (CDM) for ESD-susceptibility testing and protection design evaluation. ESD voltage thresholds are dependent on the circuit parameters used to define the model. No industry-wide standard has been adopted for the CDM. However, a standard HBM (resistance = 1500 Ω , capacitance = 100 pF) is widely used and therefore can be used for comparison purposes. The HBM ESD threshold presented here was obtained by using these circuit parameters:

| Human-Body Model ESD Threshold | |
|--------------------------------|---------|
| Device | Voltage |
| T7121 | >500 V |

Outline Diagrams

28-Pin, Plastic DIP

Dimensions are in millimeters. Controlling dimensions are in inches.

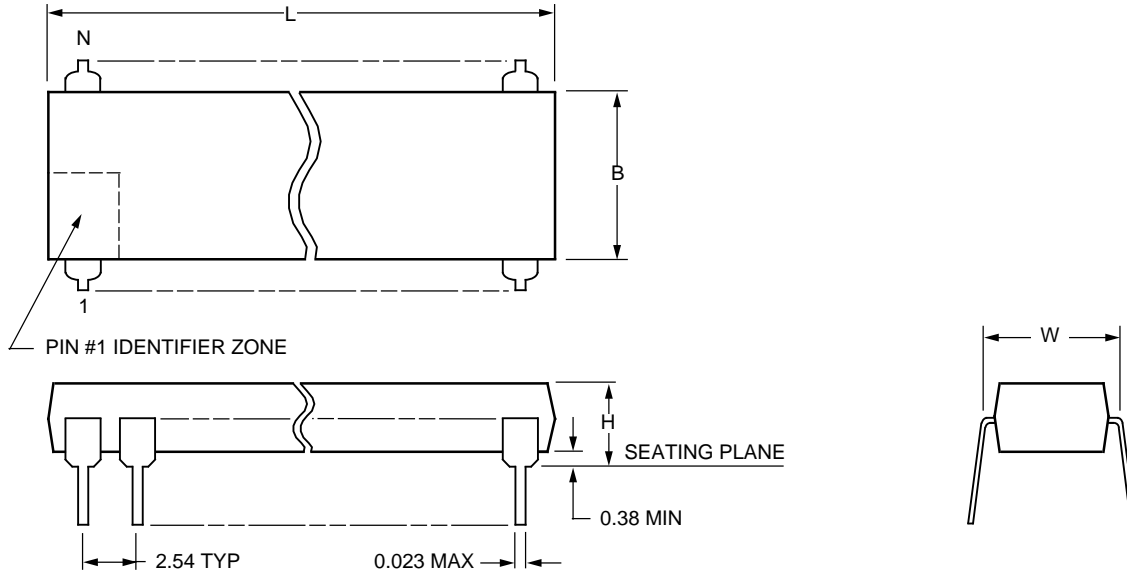

5-4410r.1

| Package Description | Number of Pins "N" | Package Dimensions | | | |
|---|--------------------|--------------------|---------------------------------|-----------------------------------|--------------------------------|
| | | Maximum Length "L" | Maximum Width Without Leads "B" | Maximum Width Including Leads "W" | Maximum Height Above Board "H" |
| PDIP6 (Plastic Dual In-Line Package) "0.600" Series | 28 | 37.34 | 13.97 | 15.49 | 5.59 |

Outline Diagrams (continued)

28-Pin, Plastic SOJ, Surface Mounting

Dimensions are in millimeters. Controlling dimensions are in inches.

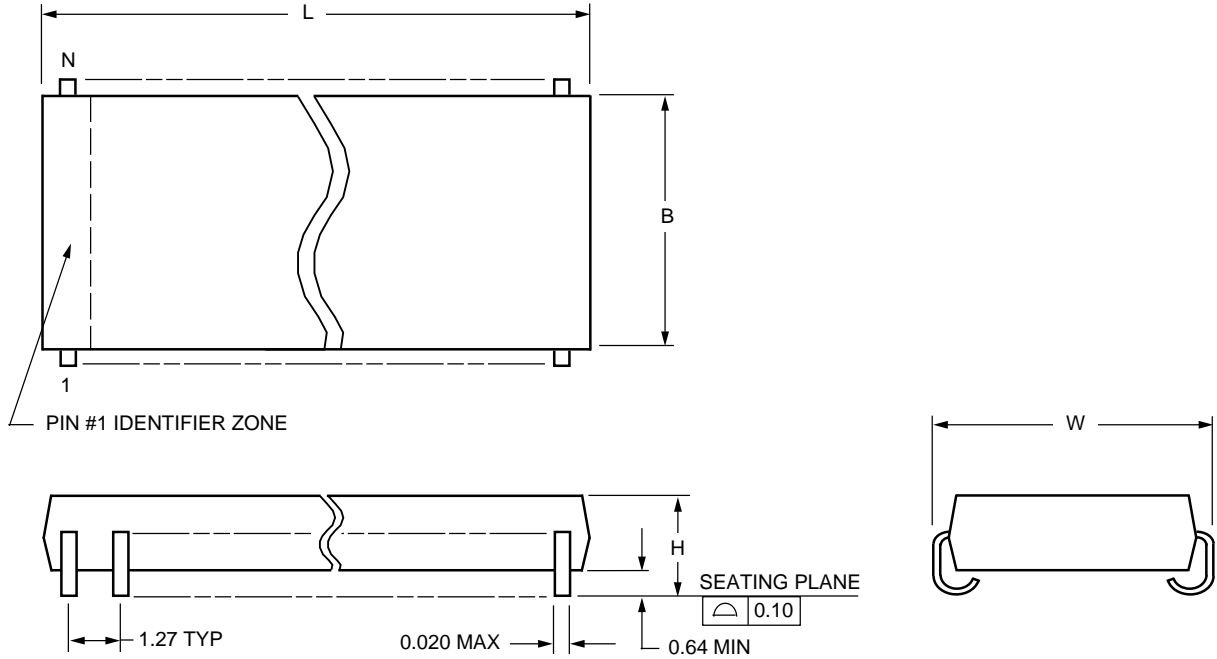

5-4413r.1

| Package Description | Number of Pins "N" | Package Dimensions | | | |
|-------------------------------|--------------------|--------------------|---------------------------------|-----------------------------------|--------------------------------|
| | | Maximum Length "L" | Maximum Width Without Leads "B" | Maximum Width Including Leads "W" | Maximum Height Above Board "H" |
| SOJ (Small-Outline J-Lead) | 28 | 18.03 | 7.62 | 8.81 | 3.18 |

Ordering Information

| Device Code | Package | Temperature |
|--------------------|---------------------|--------------------|
| T7121-PL2 | 28-Pin, Plastic DIP | -40 °C to +85 °C |
| T7121-EL2 | 28-Pin, Plastic SOJ | -40 °C to +85 °C |

Appendix

This Appendix is intended to answer questions that may arise when using the T7121 HDLC Interface for ISDN. These questions have been compiled from customer inquiries.

The questions and answers are divided into four operational categories: transparent mode, HDLC mode, general features, and power and ground.

Transparent Mode

- Q1:** Since there is no interrupt due to a MATCH, how can a MATCH be detected as soon as one occurs?
- A1:** Initially, the receive threshold should be set to 1. An interrupt will then occur on the first data byte after the MATCH. Next, the MATCH status should be read and a determination made as to whether the application requires a threshold other than 1; if it does, the threshold should be changed accordingly.
- Q2:** In transparent mode, the transmit idle character (TIC0—TIC7, AR13) and the receiver match character (RMC0—RMC7, AR12) are set to the same value and local loopback is enabled (LLOOP, R6, b1 = 1). After enabling the transmitter and receiver, the interrupt for receiver overrun occurs, and the receive FIFO is full of match characters (as expected). The end-of-frame bit (EOF, R4, b7) is also set. Is this normal?
- A2:** Yes, this is normal operation. Although end-of-frame has no meaning in transparent mode, the EOF bit acts as another indication that the receiver has been overrun.
- Q3:** In the transparent mode, what does a TDONE (R15, bit 0) of 1 mean?
- A3:** It means the transmit FIFO is empty. If the FIFO is empty in the transparent mode configuration, a TDONE interrupt will immediately occur, along with a TE interrupt, even before enabling the transmitter.

HDLC Mode

- Q4:** If the transmit FIFO is loaded and then enabled, information is sometimes lost (in the HDLC mode), is there an explanation for this?
- A4:** As soon as the FIFO is loaded, the data is prepared for HDLC transmission. If the microprocessor (which is asynchronous with the highway) turns on the transmitter at the wrong time relative to the frame sync, then the first byte is missed. The first byte is the open flag, so the first frame of HDLC data is lost.
- There are two solutions. The first one is to enable the transmitter and then load the FIFO. As long as the FIFO is loaded faster than data can be sent out, the system will operate without any abort interrupts.
- The second solution is to set the idle character to look like an open flag, then load the FIFO, and then enable the transmitter; this means there is always going to be an open flag. If the idle character is then changed to all 1s before the FIFO is empty, all subsequent frames will have the open flag, as expected, and all 1s will be sent as idle.
- Q5:** When using the first solution described for Q4, 1-byte frames cannot always be sent; why?
- A5:** One-byte frames may not be sent properly because data may be sent before the close information register can be written—if the transmitter is enabled when the FIFO is written, data may be sent as soon as the FIFO is written—resulting in a transmit abort. However, in a real HDLC environment, address information plus data usually prevents the problem from occurring.
- Q6:** Can the T7121 recognize the shared flag between consecutive frames? In other words, can the closing flag of the first frame be the opening flag of the second frame, i.e., Flag Data1 CRC CRC Flag Data2
- A6:** Yes, this is considered normal operation.
- Q7:** Regarding the EOF status byte, when the bad byte count bit (bit 4) is activated (high), does the bad CRC bit (bit 7) also activate?
- A7:** CRC bits are checked on a bit-per-bit basis. Therefore, it is possible, but very unlikely, that a bad byte count could occur without a bad CRC indication.

T7121 HDLC Interface for ISDN (HIFI-64)

Appendix (continued)

- Q8:** The T7121 is in HDLC mode, and the software views the transmit FIFO as a 32 byte x 2 FIFO. When the TE and TDONE are enabled:
1. After initializing, when the first 32 bytes transfer to the FIFO, when is the TE alert set?
 2. After writing final data into FIFO, setting TFC, and sending out this final data, are TE and TDONE asserted at the same time?
- A8:**
1. The setting of the TIL bits determines when the TE interrupt will be issued. The TE interrupt is set in HDLC mode when the chip is reset, so as soon as the TEIE mask bit is set to enable the TE interrupt, the interrupt will be asserted. In normal interrupt mode, it will remain until the interrupt register is read. In dynamic interrupt mode (DINT = 1), the interrupt will be asserted until the empty level of the FIFO is greater than the value of the TIL bits; i.e., the TIL bits set the number of empty bytes (bytes available for writing) which must be present for the TE interrupt to occur.

That is, if the TIL level is set at 32 bytes and 33 bytes are placed in the transmit FIFO, when the first byte is read from the FIFO, the TE interrupt will occur (32 bytes are now empty or available to be written to).
 2. TDONE is asserted two TCLKs after the last zero of the closing flag is transmitted; TE is asserted as indicated above. They will not usually come at the same time.
- Q9:** What happens if the transmit FIFO empties out? Should an abort be received? If this is expected, is there a solution?
- A9:** If HDLC mode is used, letting the transmit FIFO empty out completely will cause an underrun to occur and an abort to be issued. Set the transmitter interrupt level (R1, b[5—0]) to a large enough level to ensure that underruns won't occur.

General Features

- Q10:** What happens to the highway buffers when the TDM highway mode is not enabled?
- A10:** In this mode, the device sends out data on every clock. Since the device has no way of knowing when a bit is finished, i.e., when the last full clock period has ended (except by the start of the next bit clock pulse), the highway transmitter remains enabled. The output will retain the state of the most recent bit. When multiplexing other data onto the highway, an external driver should be added which is enabled only during the period when the T7121 data is on the highway.
- Q11:** Is there any reason for resetting the receiver, other than at the beginning of operation?
- A11:** Other than in the case of some type of system crash, no other reason is known.
- Q12:** Is there any problem with letting the 3-state outputs float?
- A12:** This is generally not good design practice. The bus might float in such a way that other devices, including T7121, would interpret it as valid data.
- Q13:** Please explain block move.
- A13:** To use block move, BM (R0, b3) must be set to 0 and use the ALE mode. When the ALE pulse goes low, AD6 must be a one. Then bytes are written into the T7121 FIFO on positive-going edges of WR, and they are read out of the T7121 FIFO when RD is low (timing of data is as shown in Figure 22). The only limit on the number of bytes that are read or written is that CS must be low, and you do not want to write a full FIFO or read an empty one. When block mode is used, the FIFO will read or write from the first available byte, just as in normal operation.

Appendix (continued)

Q14: Does TLBIT (R10, b6) reorder the CRC bits?

A14: Yes, the TLBIT operates on every byte, including the CRC.

Q15: When transmitting multiple frames, is it necessary to wait until one frame is transmitted before loading the next frame?

A15: No. The operation would be as follows: load the first frame, set TFC (R1, b7), then load the next frame, and set TFC again without any wait time, making sure not to overflow the transmit buffer.

Q16: Is it possible to detect the presence of a received open flag by using the MATCH capability and then changing to the HDLC mode?

A16: If there is a long enough string of open flags to permit the transmitter and receiver to be disabled, individually reset them, shift into the HDLC mode, and enable the transmitter and receiver; otherwise, the HDLC processor will not see the open flag, and the frame will be lost. Also, the transmitter will not gracefully switch states on byte boundaries, and this could be a problem at the far-end receiver.

Another approach for detecting the open flag in the transparent mode is to set the receiver fill level to 1. As soon as the flag is received, an interrupt can be issued.

Q17: In the discussion of ALOCT (AR11, b4), what is meant by "octet boundary?"

A17: If HWYEN (R0, b7) = 1, octet boundaries are aligned with time-slot boundaries. If HWYEN = 0, they are relative to (i.e., aligned with or offset by eight data clock multiples) the first receive clock edge after the receiver has been enabled (ENR, R6, b2 = 1). When ALOCT is a one, checks for match bytes are only made to data bytes aligned with octets having these boundaries.

Q18: When setting 2, 4, 8 (etc.) time slots on the CHI, is it correct to assume that the T7121 can operate the bit masking function?

A18: The bit masking option is only available when the TDM highway mode is used. Masking a received bit means that the bit is thrown away and is not passed to the receiver. When the eighth bit is passed to the receiver, it places those 8 bits in the receive FIFO. See Table 30 in the following example.

For example:

Receiver Bit Mask 01111111 = mask most significant bit (MSB), receive least significant bit (LSB) first.

Table 30. Bit Receiving and Masking

| | | | |
|-------------------------|----------|----------|----------|
| Received Bits | 11001100 | 11000001 | 11000011 |
| Mask Applied | 11111110 | 11111110 | 11111110 |
| Bits Passed to Receiver | 1100110- | 1100000- | 1100001- |

| Receive FIFO Contents | | |
|-----------------------|-----|----------------------------|
| MSB | LSB | Description |
| 1 0 1 1 0 0 1 1 | | First Word Placed in FIFO |
| 1 1 0 0 0 0 0 1 | | Second Word Placed in FIFO |
| . . . 1 0 0 0 0 | | |

Masking a transmit bit means that during the transmission time of that bit, the transmitter is 3-stated. The bit stream from the transmitter is not shifted forward; i.e., the data bits are placed in the transmit FIFO, and are then transmitted bit-by-bit by using each allocated bit time, and no bits are lost.

For example:

Transmitter Bit Mask 01111111 = mask most significant bit (MSB), receive least significant bit (LSB) first.

Table 31. Bit Transmitting and Masking

| | | | |
|---------------------|----------|----------|----------|
| Mask Applied | 11111110 | 11111110 | 11111110 |
| Transmit Pin Output | 0101010Z | 1001100Z | 11 . . . |

| Transmit FIFO Contents | | |
|------------------------|-----|------------------------|
| MSB | LSB | Description |
| 1 1 0 0 1 1 0 0 | | Transmit FIFO Contents |
| 1 0 1 0 1 0 1 0 | | First Byte to Transmit |

Note: The effective data rate is 56 Kbytes/s.

Q19: An unexpected TE occurs in R15 at the start of transmission. Why?

A19: The unexpected TE is most likely the initial transmitter empty flag generated after reset. After powerup or reset, the TE bit will be set (because the FIFO is initially empty).

Appendix (continued)

Power and Ground

Q20: Are there any warning signs that indicate poor grounding practices have been used?

A20: If errors occur which do not appear to be due to software or to the external communications link, then loop the T7121 data path back at the concentration highway. Any data transmitted should be received error-free. If there are errors, poor grounding might be the cause. Look for glitches on RESET and WR leads. Connect RESET to ground and do a software reset; if the error rate improves, RESET is being glitched and improved grounding should help.

Notes

For additional information, contact your Microelectronics Group Account Manager or the following:

INTERNET: <http://www.lucent.com/micro>

U.S.A.: Microelectronics Group, Lucent Technologies Inc., 555 Union Boulevard, Room 30L-15P-BA, Allentown, PA 18103

1-800-372-2447, FAX 610-712-4106 (In CANADA: **1-800-553-2448**, FAX 610-712-4106), e-mail docmaster@micro.lucent.com

ASIA PACIFIC: Microelectronics Group, Lucent Technologies Singapore Pte. Ltd., 77 Science Park Drive, #03-18 Cintech III, Singapore 118256

Tel. (65) 778 8833, FAX (65) 777 7495

JAPAN: Microelectronics Group, Lucent Technologies Japan Ltd., 7-18, Higashi-Gotanda 2-chome, Shinagawa-ku, Tokyo 141, Japan

Tel. (81) 3 5421 1600, FAX (81) 3 5421 1700

For data requests in Europe:

MICROELECTRONICS GROUP DATALINE: **Tel. (44) 1734 324 299**, FAX (44) 1734 328 148

For technical inquiries in Europe:

CENTRAL EUROPE: **(49) 89 95086 0** (Munich), NORTHERN EUROPE: **(44) 1344 865 900** (Bracknell UK),

FRANCE: **(33) 1 41 45 77 00** (Paris), SOUTHERN EUROPE: **(39) 2 6601 1800** (Milan) or **(34) 1 807 1700** (Madrid)

Lucent Technologies Inc. reserves the right to make changes to the product(s) or information contained herein without notice. No liability is assumed as a result of their use or application. No rights under any patent accompany the sale of any such product(s) or information.

