

Data Sheet  
April 1998

microelectronics group

Lucent Technologies  
Bell Labs Innovations



## T7264 U-Interface 2B1Q Transceiver

### Features

- U-interface 2B1Q transceiver
  - Range over 18 kft on 26 AWG
  - ISDN basic-rate 2B+D
  - Full-duplex, 2-wire operation
  - 2B1Q four-level line code
  - Conforms to ANSI North American Standard T1.601-1992
  - Supports NT quiet mode and insertion loss test mode for maintenance
- K2 interface
  - 2B+D data
  - 512 kbits/s TDM interface
  - Frame and superframe markers
  - Embedded operations channel (eoc)
  - U-interface M bits and crc results
  - Device control and status
- Other
  - Single +5 V ( $\pm 5\%$ ) supply
  - $-40^\circ\text{C}$  to  $+85^\circ\text{C}$
  - 44-pin PLCC
- Power consumption
  - Operating 275 mW typical
  - Idle mode 30 mW typical
- Analog front end
  - On-chip line driver for 2.5 V pulses
  - On-chip balance network

- Sigma-delta A/D converter
- Internal 15.36 MHz crystal oscillator
- Supports 15.36 MHz external clock input
- Digital signal processor
  - Digital timing recovery (pull range  $\pm 250$  ppm)
  - Echo cancellation (linear and nonlinear)
  - Accommodates distortion from bridged taps
  - Scrambling/descrambling
  - crc calculations
  - Selectable LT or NT operation
  - Start-up sequencing with timers
  - Activation/deactivation support
  - Cold start in 3.5 seconds (typical)
  - Warm start in 200 ms (typical)
  - U-frame formatting and decoding

### Description

The Lucent Technologies Microelectronics Group T7264 U-Interface 2B1Q Transceiver integrated circuit provides full-duplex, basic-rate (2B+D) integrated services digital network (ISDN) communications on a 2-wire digital subscriber loop at either the LT or NT and conforms to the ANSI North American Standard T1.601-1992. The single +5 V CMOS device is packaged in a 44-pin plastic leaded chip carrier (PLCC).

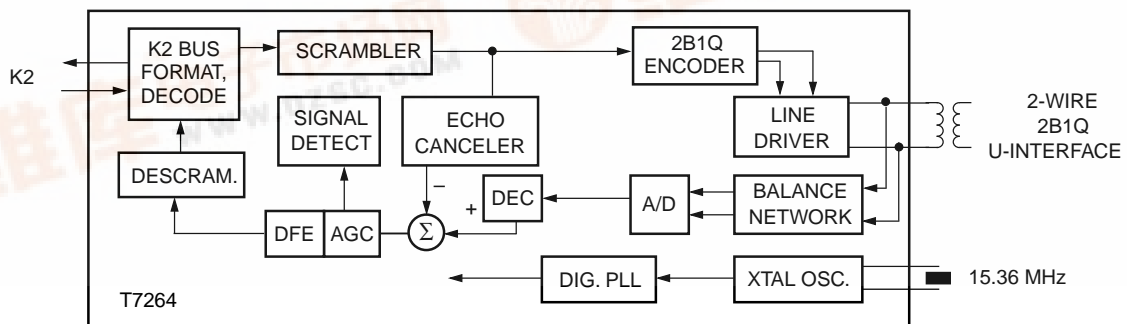

Figure 1. T7264 Simplified Block Diagram



Table of Contents

Contents	Page	Contents	Page
Features .....	1	Figure 9. K2 Octets .....	11
Description .....	1	Figure 10. K2 Interface LT and NT .....	12
Pin Information .....	3	Figure 11. K2 Interface Frame Format .....	14
Functional Overview .....	6	Figure 12. U-Interface Frame and Superframe .....	21
Device Interface and Connections .....	7	Figure 13. U-Interface Superframe Bit Groups .....	21
Analog Device Interface .....	7	Figure 14. K2 Octet Description .....	22
Power Supply Connections .....	8	Figure 15. K2 Functional Description .....	22
Clock Operation .....	8	Figure 16. K2-to-U Mapping .....	23
Reset Operation .....	8	Figure 17. U-to-K2 Mapping .....	24
Reset Sequences and Clock Synchronization .....	8	Figure 18. K2 Response Timing .....	24
Reset Time .....	9	Figure 19. T7264 nebe/febe/crc Block Diagram .....	28
Idle Mode .....	10	Figure 20. Use of rfebe in a Multilink Configuration .....	28
NT Maintenance .....	10	Figure 21. State Sequence for DSL Transceiver Start-Up .....	32
K2 Interface Description .....	11	Figure 22. Loop Application .....	33
K2 NT and LT Timing Sources .....	12	Figure 23. 2-Wire Terminal Application .....	33
K2 Bits Description .....	13	Figure 24. Digital Pair Gain Application .....	33
K2 Bit Levels .....	20	Figure 25. Timing Diagram Referenced to F .....	37
U-Interface Description .....	21	Figure 26. Timing Diagram Referenced to C .....	37
K2 Functional Description .....	22	Figure 27. RESET Timing Diagram .....	38
K2 Framing Bits .....	23	Figure 28. Switching Test Waveform .....	38
K2 eoc and Loopback Response Timing .....	24		
K2 Device Status and Control Bits .....	25		
The adea Bit .....	26		
The nebe, febe, rfebe, and crc Bits .....	27		
NT or LT Operation .....	28		
Minimal Example .....	29		
Activation and the K2 Interface .....	30		
Priority .....	31		
Applications .....	32		
Absolute Maximum Ratings .....	34		
Handling Precautions .....	34		
Recommended Operating Conditions .....	34		
Electrical Characteristics .....	35		
Loop-Range Performance Characteristics .....	36		
Timing Characteristics .....	37		
Switching Test Input/Output Waveform .....	38		
Outline Diagram .....	39		
Ordering Information .....	39		
Appendix A. Questions and Answers .....	40		
Introduction .....	40		
U-Interface .....	40		
K2 Interface .....	46		
Miscellaneous .....	49		
Appendix B. Differences Between the T-7264- -ML, T-7264- -ML2 and T-7264A- -ML Devices .....	53		
Technology .....	53		
Standard .....	53		

List of Tables

Table 1. Pin Functions .....	3
Table 2. Pin Descriptions .....	4
Table 3. Clock Configuration .....	6
Table 4. K2 Interface Serial Data Bit Map .....	13
Table 5. B1, B2, D, and S1 Octets (Overview) .....	15
Table 6. B1, B2, D, and S1 Octets (Functions) .....	15
Table 7. UM1 and UM2 Octets—eoc Bits (Overview) .....	16
Table 8. UM1 and UM2 Octets—eoc Bits (Functions) .....	16
Table 9. UM2 and UM3 Octet—UCS Bits (Overview) .....	17
Table 10. UM2 and UM3 Octet—UCS Bits (Functions) .....	17
Table 11. DS Octet (Overview)—Device Status .....	18
Table 12. DS Octet (Functions)—Device Status .....	18
Table 13. DC Octet (Overview) .....	19
Table 14. DC Octet (Functions) .....	19
Table 15. K2 Data Out (DO) Bit Levels .....	20
Table 16. K2 Device Control (DC) Bit Levels .....	20
Table 17. U-Interface Bit Assignment .....	22
Table 18. DC Octet Description (Control) .....	25
Table 19. DS Octet Description (Status) .....	25
Table 20. adea, Idea, and dea Function .....	26
Table 21. MODE0 Pin Functionality .....	28
Table 22. Minimal Implementation .....	29
Table 23. Definitions of Signals During Start-Up .....	31
Table 24. Power Consumption .....	35
Table 25. Performance Ratings .....	35
Table 26. Crystal Characteristics: Fundamental Mode Crystal .....	35
Table 27. Internal PLL Characteristics .....	36
Table 28. Digital dc Characteristics (Over Operating Ranges) .....	36
Table 29. Clock Timing .....	37
Table 30. MTC Requirements and Characteristics (LT Mode) .....	38
Table 31. RESET Timing .....	38

List of Figures

Figure 1. T7264 Simplified Block Diagram .....	1
Figure 2. Pin Diagram .....	3
Figure 3. Quat Example .....	6
Figure 4. Line Interface and Protection .....	7
Figure 5. Recommended Power Supply Connections .....	8
Figure 6. RESET Waveform Normal Operation .....	9
Figure 7. RESET Timing for Synchronized Clocks .....	9
Figure 8. K2 Interface Timing .....	11

### Pin Information

The U transceiver consists of a single chip composed of an analog front end (which performs the line interfacing and data conversion functions) and a digital signal processor (which performs the algorithm-specific signal processing, control, and access functions).

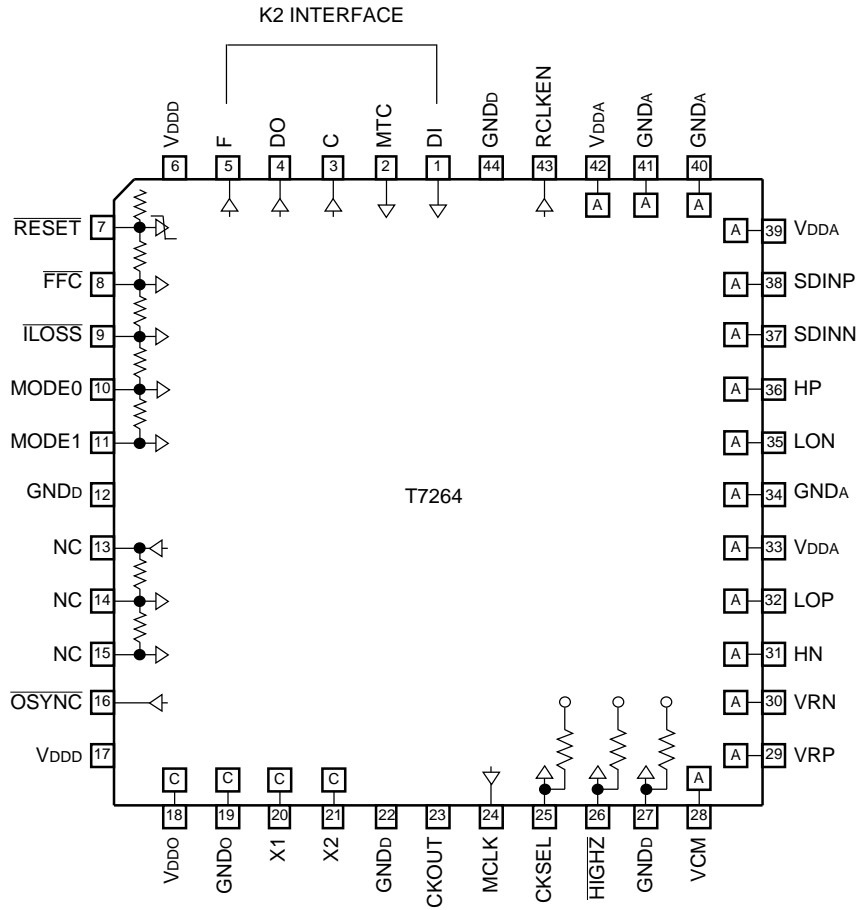

5-5804(F)

Notes:  
C = crystal oscillator pins.  
A = analog pins.

Figure 2. Pin Diagram

Table 1. Pin Functions

Device Pin Function	Type	Number of Pins
+5 V Power & Ground (V <sub>DD</sub> , GND)	Power	14
Analog Line Interface (HP, HN, LOP, LON)	Analog	4
Voltage Reference (VRP, VRN, VCM)	Analog	3
Receiver to A/D Converter (SDINN, SDINP)	Analog	2
Clock Related (X1, X2, CKOUT, CKSEL, MCLK, RCLKEN)	Digital	6
K2 Interface Connection (MTC, C, DI, DO, F)	Digital	5
Device Status & Control ( $\overline{\text{FFC}}$ , $\overline{\text{HIGHZ}}$ , $\overline{\text{ILOSS}}$ , MODE0, MODE1, $\overline{\text{OSYNC}}$ , $\overline{\text{RESET}}$ )	Digital	7
Do Not Connect	NC	3
Total	—	44

T7264 U-Interface 2B1Q Transceiver

Pin Information (continued)

Table 2. Pin Descriptions

Pin	Symbol	Type	Name/Function												
1	DI	I	<b>K2 Transmit Data Input.</b> Serial data input passing transmit data across K2 interface at 512 kbits/s. Latched on falling edge of C clock.												
2	MTC	I	<b>Master Timing Clock.</b> 8 kHz clock input. In LT mode (MODE0 = 1), all clocks except CKOUT in the 15.36 MHz and 7.68 MHz modes are locked to this input clock. In the NT mode (MODE0 = 0), this input is not used.												
3	C	O	<b>512 kbits/s K2 Bit Clock Output.</b> Synchronized to F. Defines K2 bit period (rising edge to rising edge).												
4	DO	O	<b>K2 Receive Data Output.</b> Serial data output passing receive data across K2 interface at 512 kbits/s. Changes on the rising edge of C clock.												
5	F	O	<b>8 kHz Clock Output.</b> Defines K2 frame (rising edge to rising edge). In LT mode (MODE0 = 1), this clock is locked to MTC at 0° phase shift with ±65 ns of jitter (for jitter-free MTC). In NT mode (MODE0 = 0), this clock is derived from the U-interface signal.												
6, 17	V <sub>DDD</sub>	P	<b>+5 V Supply for Digital Circuits.</b> Internally connected together.												
7	$\overline{\text{RESET}}$	I	<b>Reset (Active-Low).</b> Asynchronous Schmitt trigger input. This pin maintains the transceiver in reset indefinitely without the need to access the K2 interface. It must be held low for three consecutive F clock periods for active or idle mode or 1.5 ms after power on. After power-on reset or idle mode reset, an additional 1.0 ms is required before the device is fully functional. $\overline{\text{RESET}}$ overrides all other transceiver control signals, halts loop transmission, clears the transceiver adaptive filter coefficients, and resets the phase-locked loop. After a reset, the next activation is a cold start. Unlike afrst (software reset via the K2 interface), when this pin is held low, synchronization is lost between F and MTC (LT). After this pin goes high, F and MTC regain synchronization. All output clocks remain functional during reset.												
8	$\overline{\text{FFC}}$	I	<b>Freeze Frequency Control (Active-Low).</b> Asynchronous input. Freeze the clock frequency control (i.e., the internal state variables of the timing recovery remain constant). This control is operative in both LT and NT modes. This pin is latched on the rising edge of every RCLKEN.												
9	$\overline{\text{ILOSS}}$	I	<b>Insertion Loss Test (Active-Low).</b> NT ONLY. When enabled, the transmitter continuously transmits the sequence SN1. The receiver remains reset. The transceiver performs a reset when this pin returns to its inactive state. $\overline{\text{ILOSS}}$ is latched on the rising edge of F. Leave this pin unconnected or tied to V <sub>DD</sub> in LT mode.												
10, 11	MODE[0:1]	I	<b>Mode 0 and 1.</b> Two-pin field selecting chip mode: <table style="margin-left: 20px; border: none;"> <tr> <td style="padding-right: 20px;"><u>MODE0</u></td> <td><u>Action</u></td> </tr> <tr> <td>0</td> <td>Configure for chip being used on the NT end of loop.</td> </tr> <tr> <td>1</td> <td>Configure for chip being used on the LT end of loop.</td> </tr> <tr> <td style="padding-right: 20px;"><u>MODE1</u></td> <td><u>Action</u></td> </tr> <tr> <td>0</td> <td>Disables autoreporting of nebe to febe.</td> </tr> <tr> <td>1</td> <td>Enables autoreporting of nebe to febe.</td> </tr> </table>	<u>MODE0</u>	<u>Action</u>	0	Configure for chip being used on the NT end of loop.	1	Configure for chip being used on the LT end of loop.	<u>MODE1</u>	<u>Action</u>	0	Disables autoreporting of nebe to febe.	1	Enables autoreporting of nebe to febe.
<u>MODE0</u>	<u>Action</u>														
0	Configure for chip being used on the NT end of loop.														
1	Configure for chip being used on the LT end of loop.														
<u>MODE1</u>	<u>Action</u>														
0	Disables autoreporting of nebe to febe.														
1	Enables autoreporting of nebe to febe.														
12, 22, 27, 44	GND <sub>D</sub>	P	<b>Ground Supply for Digital Circuits.</b> Internally connected together.												

**Pin Information** (continued)

**Table 2. Pin Descriptions** (continued)

Pin	Symbol	Type	Name/Function
13, 14, 15	NC	—	<b>No Connect.</b> These pins are connected to internal nodes of the device. Make no connection to them.
16	OSYNC	O	<b>Out of Sync (Active-Low).</b> Indicates that framing on the loop signal has not been acquired (or has been lost). Equivalent to the K2 interface oof bit in the DS octet. Can sink or source 1.6 mA to drive a low-current external LED. Clocked out on the rising edge of C.
18	VDDO	P/I	<b>+5 V Supply for the Crystal Oscillator.</b> Ground when driving MCLK with an external 15.36 MHz clock.
19	GND <sub>O</sub>	P	<b>Ground Supply for Oscillator.</b>
20	X1	I	<b>Connection #1 for a 15.36 MHz Crystal.</b>
21	X2	I	<b>Connection #2 for a 15.36 MHz Crystal.</b>
23	CKOUT	O	<b>Clock Output.</b> See Table 3.
24	MCLK	I	<b>Master Clock.</b> See Table 3.
25	CKSEL	I	<b>Clock Select.</b> See Table 3.
26	HIGHZ	I	<b>High Impedance (Active-Low).</b> Causes all digital outputs to become 3-stated.
28	VCM	—	<b>Common-Mode Voltage Reference for the Analog Circuits.</b> Connect via a 0.1 $\mu$ F capacitor to GND <sub>A</sub> as close to this pin and pin 34 as possible.
29	VRP	—	<b>Positive Voltage Reference for the Analog Circuits.</b> Connect via a 0.1 $\mu$ F capacitor to GND <sub>A</sub> as close to this pin and pin 34 as possible.
30	VRN	—	<b>Negative Voltage Reference for the Analog Circuits.</b> Connect via a 0.1 $\mu$ F capacitor to GND <sub>A</sub> as close to this pin and pin 34 as possible.
31	HN	I	<b>Hybrid Network Connection, Negative Side.</b> Connect directly to the negative side of the transformer.
32	LOP	O	<b>Line Driver Output Terminal, Positive Side.</b> Connect to the positive side of the transformer.
33, 39, 42	VDDA	P	<b>+5 V Supply for Analog Circuits.</b>
34, 40, 41	GND <sub>A</sub>	P	<b>Ground Supply for Analog Circuits.</b>
35	LON	O	<b>Line Driver Output Terminal, Negative Side.</b> Connect to the negative side of the transformer.
36	HP	I	<b>Hybrid Network Connection, Positive Side.</b> Connect directly to the positive side of the transformer.
37	SDINN	I	<b>Sigma-Delta A/D Converter Input, Negative Side.</b> Connect via an 820 pF $\pm$ 5% capacitor to SDNIP.
38	SDINP	I	<b>Sigma-Delta A/D Converter Input, Positive Side.</b> Connect via an 820 pF $\pm$ 5% capacitor to SDNIN.
43	RCLKEN	O	<b>80 kHz Receive Baud Clock.</b> Defines receive baud period (rising edge to rising edge).

Pin Information (continued)

Table 3. Clock Configuration

V <sub>DDO</sub>	MCLK	CKSEL	CKOUT*
+5 V	0	0	15.36 MHz (free-running)
+5 V	0	1	10.24 MHz (phase-locked)
+5 V	1	0	7.68 MHz (free-running)
+5 V	1	1	3-stated (default)
0 V	15.36 MHz	0	15.36 MHz (free-running)
0 V	15.36 MHz	1	3-stated

\* The 10.24 MHz CKOUT is high for one-half of a 15.36 MHz period and low for one 15.36 MHz period. To compensate for the difference between the phase-locked and free-run frequencies, one-half 15.36 MHz clock periods are occasionally either removed from or added to the low time of the 10.24 MHz period.

Functional Overview

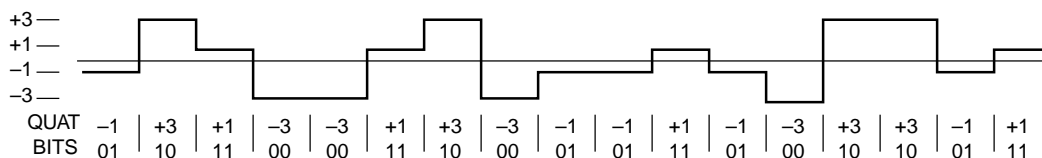

5-5162F

Figure 3. Quat Example

The T7264 chip conforms to the T1.601 ANSI North American 1992 Standard for 2B1Q line encoding. The 2B1Q line code provides a four-level pulse amplitude modulation code with no redundancy. Data is grouped into pairs of bits for conversion to quaternary (quat) symbols. Figure 3 above shows an example of this coding method.

The analog front end provides the 2B1Q line coder (D/A conversion), pulse shaper, line driver, first-order line balance network, crystal oscillator clock generation, and sigma-delta A/D conversion. The line driver provides pulses which allow the 2.5 V template of the T1.601 specification to be met when connected to the proper transformer and interface circuitry. The A/D converter is implemented using a double-loop, sigma-delta modulator.

A crystal oscillator provides the 15.36 MHz master clock for the chip. An on-chip, digital phase-locked loop provides the ability to synchronize the chip clock to the system clock in the LT or to the line clock in the NT.

Provisions are made for using either an on-chip crystal oscillator with an external crystal, or using an external clock source.

The T7264 takes input at the K2 interface and formats this information for the U-interface through a scrambling algorithm and the addition of synchronization bits for U framing. This data is then transferred to the 2B1Q encoder for transmission over the U loop. Signals coming from the U loop are first passed through the sigma-delta A/D converter and then sent for extensive signal processing. The T7264 provides decimation of the sigma-delta output (DEC), linear and nonlinear echo cancellation, automatic gain control (AGC), signal detection, decision feedback equalization (DFE), timing recovery (TR), descrambling, line-code polarity detection, and rate adaption for output onto the K2 interface. The DFE circuit provides the functionality necessary for proper operation on subscriber loops with bridged taps.

## Functional Overview (continued)

The device provides rapid cold start and warm start operation. From a cold start, the device is typically operational within 3.5 s. The device supports activation/deactivation, and, when properly deactivated, it stores the adaptive filter coefficients such that upon the next activation request, a faster warm start is possible. A warm start typically requires 200 ms for the device to become operational.

The T7264 has an on-chip activation/deactivation state machine and timers, and automatically moves from state T0 to T7 (as specified in the T1.601 standard) during activation. This simplifies the implementation of the T1.601 (Appendix C) state table. The signals from the device control and status octets on the K2 interface provide the control necessary to complete the state table. The activation/deactivation process is controlled over the K2 interface.

The T7264 has a low-power mode which it automatically enters when it is in the idle state. The idle state occurs after deactivation, loss of sync on the U-interface, or releasing reset. In the low-power mode, power consumption is typically 30 mW.

## Device Interface and Connections

The T7264 transceiver allows systems to meet the loop-range requirements of ANSI Standard T1.601 when the transceiver is used with the proper peripheral circuitry. Devices achieve better than  $10^{-7}$  bit error rate over 18 kft of 26 AWG loop cable.

### Analog Device Interface

Proper line termination is required, utilizing appropriate interface components, to meet the 2.5 V pulse template. The output of the T7264 should first pass through a pair of  $16.9 \Omega$  resistors and into a 1.5:1 ratio transformer, such as the Lucent 2754H (or the short-lead version 2754H2). The output of the transformer is coupled through a  $1.0 \mu\text{F}$  capacitor, is passed through a pair of  $16.9 \Omega$  resistors, and then drives the  $135 \Omega$  line.

Surge protection circuitry is necessary on each side of the transformer when the U loop is external to a building. The protection between the  $16.9 \Omega$  resistors and the transformer should be a Lucent 521A surge protector or equivalent. A relay may be needed to disconnect the loop plant for local loopback testing. Figure 4 shows a recommended circuit for interfacing the T7264 to the line; however, the specific interface is system dependent.

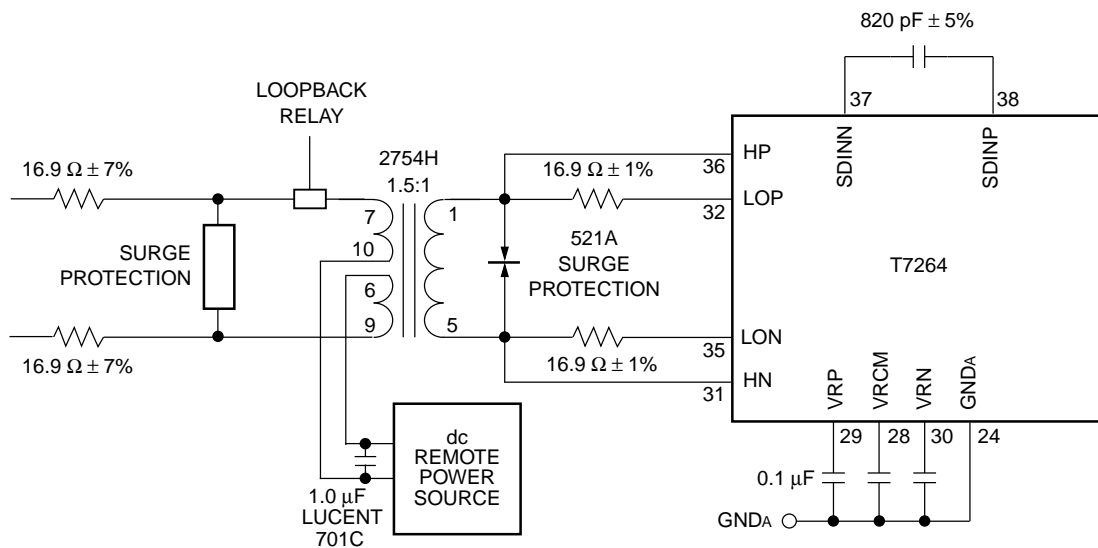

5-5803Fa

Note:  $3000 \text{ pF} \pm 1\%$  capacitors from HP and HN to  $\text{GND}_A$  may improve operation of the tone decoder in the presence of interfering common-mode signals.

Figure 4. Line Interface and Protection

T7264 U-Interface 2B1Q Transceiver

Device Interface and Connections

(continued)

Power Supply Connections

Figure 5 shows a recommended power supply connection. C is a 10  $\mu\text{F}$  capacitor. Each pair of power and ground pins should be decoupled with 0.1  $\mu\text{F}$  and 1.0  $\mu\text{F}$  capacitors. Each of the three leads (VCM, VRP, and VRN) associated with the voltage reference should be decoupled with 0.1  $\mu\text{F}$  capacitors. Place the capacitors as close as possible to the power or reference and ground pins which they decouple.

Clock Operation

The master clock for the T7264 may either be internally generated by the on-chip crystal oscillator or supplied by the user via the MCLK pin. In the latter case, VDDO must be grounded. In the LT mode, an on-chip digital phase-locked loop phase locks the F clock to the externally supplied MTC clock, unless FFC is active-low. In NT mode, F synchronizes to the signal received from the LT through the U-interface. If the on-chip crystal oscillator is used, the crystal must conform to the requirements given in Table 26.

Reset Operation

The T7264 can be reset via the K2 interface (issuing afirst for three consecutive K2 frames) or via hardware (RESET). The only difference between these two resets is that, in the LT mode, the timing recovery filter is reset

only by a hardware reset. The RESET pin can be used to hold the transceiver in reset indefinitely. If a hardware reset is used when the chip is being powered up, RESET must be held low for 1.5 ms; however, if the chip is already powered up, then holding RESET low for three K2 frames is sufficient.

The reset state is terminated, and the chip enters idle mode on the K2 frame following the end of the reset signal.

Reset Sequences and Clock Synchronization

In normal use, a power-on reset can be obtained by connecting a capacitor to the RESET pin. The internal pull-up resistor, acting with an on-chip Schmitt trigger on this pin, can be used to reset the chip. In this case, the RESET waveform is shown in Figure 6.

When using this reset procedure, the various clocks generated by the transceiver are not synchronized. However, during testing, it can be useful to initialize all the counters of the clock generator so that the various clocks generated by the transceiver can be synchronized to the test equipment. The RESET pin can accomplish this by applying the sequence shown in Figure 7. Furthermore, the RESET pin transitions should align with falling edges of MCLK. If the internal crystal oscillator is used, this can be accomplished by configuring CKOUT for 15.36 MHz and ensuring that RESET transitions align with the falling edge of CKOUT. The user should be aware, however, that if this clock synchronization reset sequence is used after a period of normal operation, the phase of the clocks generated by the T7264 (such as F, RCLKEN, C, CKOUT, etc.) may suddenly change as a result of the clock resynchronization.

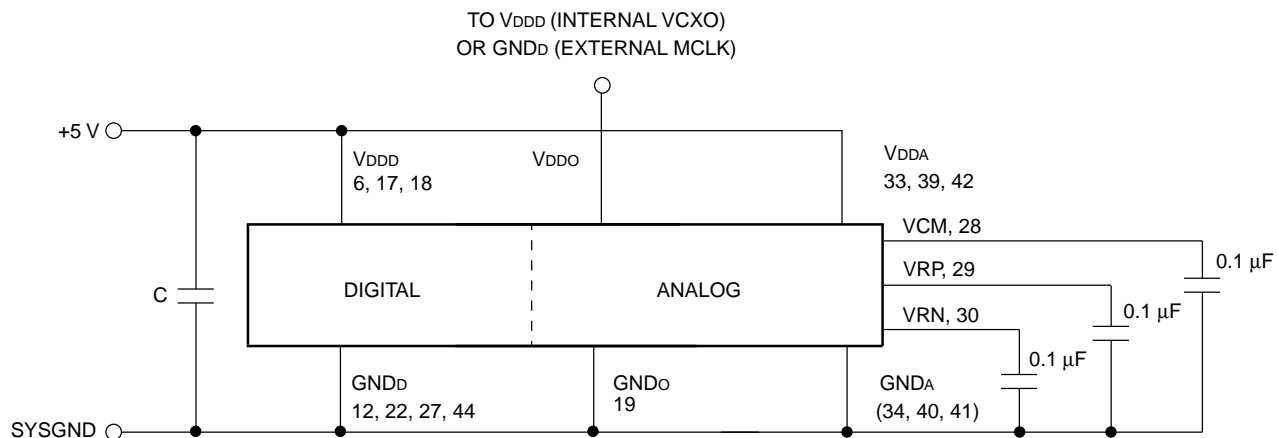

5-5164a

Figure 5. Recommended Power Supply Connections



**Device Interface and Connections** (continued)

**Reset Time**

Reset time depends on the conditions under which the chip is reset. There are three cases to consider:

- When the chip is initially powered on, the  $\overline{\text{RESET}}$  pin must be held low (below 0.5 V) for 1.5 ms. This allows 1.0 ms for the oscillator start-up and 0.5 ms for the digital reset process. An additional 1.0 ms is needed to allow the analog circuitry to fully power up before the chip becomes fully functional.
- When the chip is in the idle mode, a software or hardware reset, applied for a minimum of three K2 frames, starts the reset process. As before, the analog circuitry requires an additional 1.0 ms before the chip becomes fully functional.
- If the chip is already fully powered up and functional, a software or hardware reset, applied for a minimum of three K2 frames, is sufficient to complete the reset process.

When the chip is in the reset state, the output of the line driver is at 0 V and the transmit data is also 0 V.

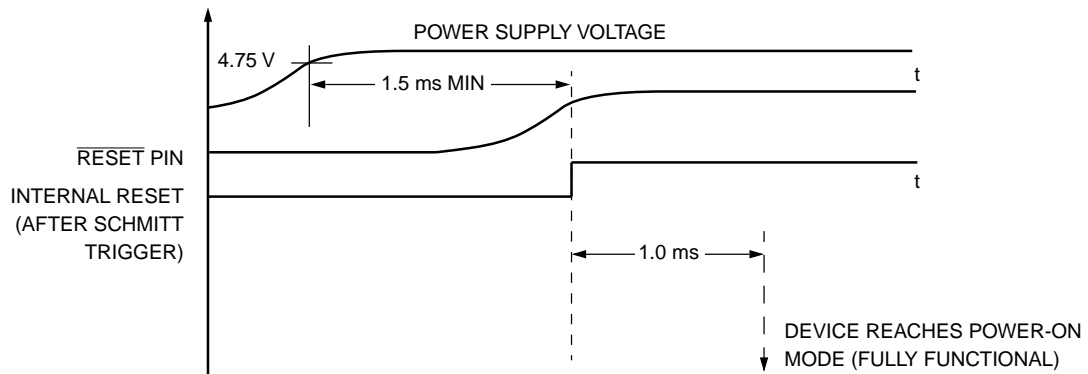

5-5165a

**Figure 6.  $\overline{\text{RESET}}$  Waveform Normal Operation**

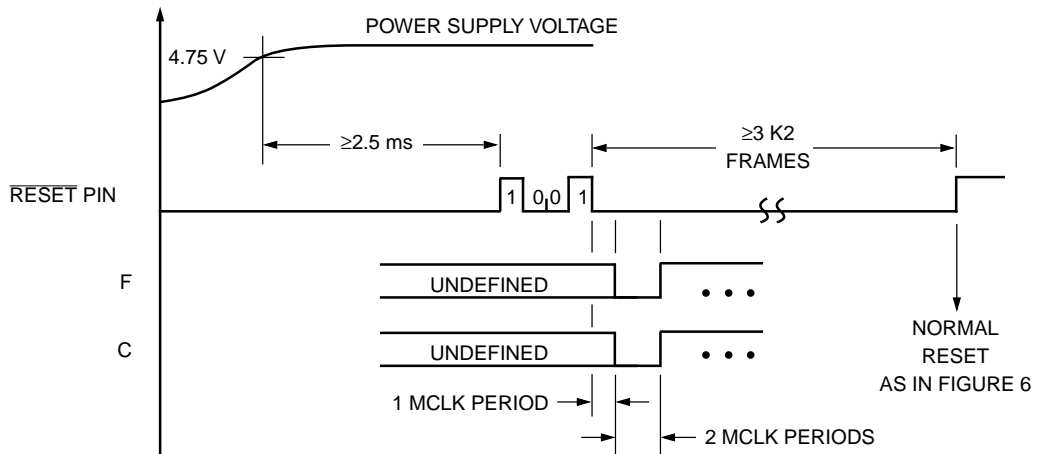

5-5166a

**Figure 7.  $\overline{\text{RESET}}$  Timing for Synchronized Clocks**

## Device Interface and Connections

(continued)

### Idle Mode

A low-power idle mode is implemented on the T7264 to reduce the power consumption to typically 30 mW when it is not active. All internal coefficients are saved in this idle mode to reduce time for a subsequent start-up. There are three ways that idle mode can be entered:

- If the loop is operational, the local deactivation command (Idea) in the LT mode via the K2 interface causes the deactivation procedure specified in the ANSI standard. At the conclusion of the deactivation procedure, shutdown of the line driver and activation of the tone detector occurs. If no tone is detected within 48 ms, the idle mode is entered. This 48 ms window constitutes the RECEIVE RESET criteria in the ANSI standard.
- If a failure condition is encountered (e.g., the loop never comes up), a procedure similar to deactivation is followed. The only difference is the duration of the window, which is set internally by the type of failure condition.
- As long as either the afrst (via the K2 interface) or the  $\overline{\text{RESET}}$  pin is active, the transceiver remains in the powerup reset state. At the cessation of the reset condition, the transceiver changes to the idle state.

There are four ways of bringing the device out of the idle mode:

- An initiate start-up procedure (istp) command is received via the K2 interface by the device.
- A reset (afrst or external  $\overline{\text{RESET}}$ ) command is received by the device.
- A tone is detected by the tone detector.
- A command to enter any of the test modes (loopback and insertion loss) is received by the device.

Internal timing ensures that the digital signal processor blocks do not change state during the idle mode-to-powerup process. In addition, the start-up process has been designed to prevent glitches on the line as the driver powers up.

### NT Maintenance

ANSI T1.601-1992 defines NT quiet mode operation and an insertion loss measurement, and support for these is available from the T7264. Detection of the trigger signals is done by other hardware which notifies the system controller, and the system controller then signals the T7264 as needed to do the following:

- To enter the quiet mode, the chip is placed in reset.
- When an insertion loss measurement is requested,  $\overline{\text{ILOSS}}$  (pin 9) is asserted low. This causes the transmitter to continuously send SN1 and places the receiver in reset. When the test is completed or terminated,  $\overline{\text{ILOSS}}$  is asserted high and the chip is reset. Priority between  $\overline{\text{RESET}}$  and  $\overline{\text{ILOSS}}$  is described in the Priority section of this document (page 31).

### K2 Interface Description

The K2 interface consists of five pins on the T7264: the data out (DO), data in (DI), data clock (C), K2 frame sync (F), and master timing clock (MTC). C is a 512 kHz output signal for clocking data into and out of the device with 1 bit per clock cycle. F is an 8 kHz signal indicating the beginning of a K2 frame. MTC is used in LT mode and must be an 8 kHz  $\pm$  32 ppm system clock to meet T1.601 requirements.

In LT mode, F is phase-locked to the MTC input through the on-chip digital phase-locked loop. Jitter in MTC is tracked by F at frequencies below 0.5 Hz. MTC jitter at frequencies higher than 0.5 Hz is attenuated by the phase-locked loop (PLL). In the NT mode, the F clock is derived from incoming data from the U loop.

The first bit of a K2 frame begins simultaneously with the rising edge of F. Transitions on DO occur following the rising edge of C, and DI is latched on the falling edge of C. Figure 8 shows the relationship between the C, F, DO, and DI.

The K2 frame consists of eight octets for a total of 64 bits. These bits are transferred synchronously over a 512 kHz interface with a frame rate of 8 kHz or 125  $\mu$ s. The major purpose of the K2 interface is to provide 2B+D data transfer between other devices and the chip. In addition, there are framing bits (DF), U-interface maintenance and control bits (UM), and device control/status bits (DC/DS).

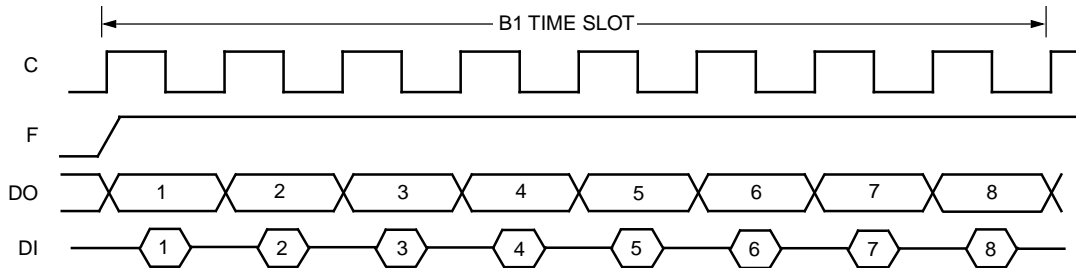

5-5167F

Figure 8. K2 Interface Timing

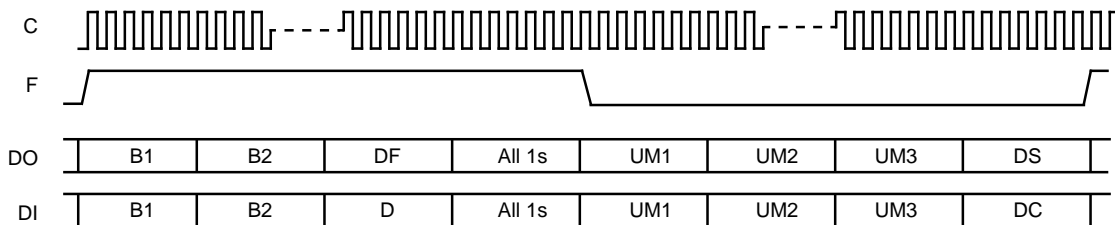

5-5158

Figure 9. K2 Octets

**K2 Interface Description** (continued)

**K2 NT and LT Timing Sources**

In LT applications, all devices typically derive their timing from the same MTC. Additional logic in the LT, such as a T7270, can provide concentration of multiple K2 interfaces onto a single higher-speed highway.

In a PBX application, the U-interface loops can be used as trunks. If more than one incoming U trunk is to be used, additional circuitry may be needed to provide

elastic store, time-slot allocation, and master frame timing to synchronize the K2 interfaces received at each trunk onto a common interface.

In NT1 applications, K2 frame timing is also derived from the received 2B1Q data on the U loop. A T7264 chip can be connected to an S/T-interface device (such as the T7252A) to form an NT1. Figure 10 shows the K2 interface connection in a CO application and NT1 application. For terminal applications, the derived K2 timing could be the source of all timing within the equipment (if only a single U-interface is needed).

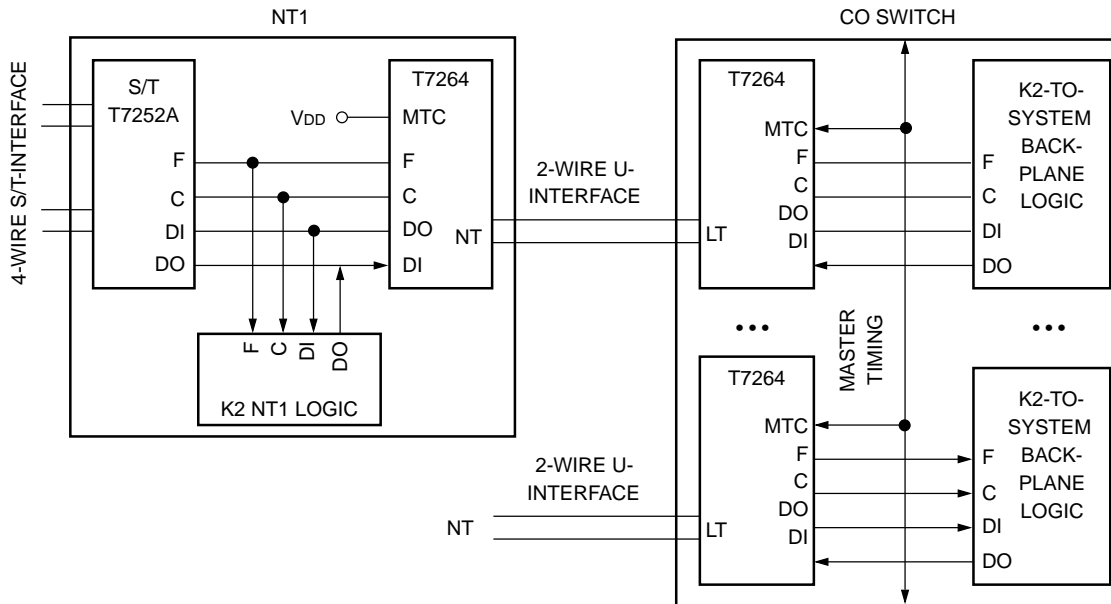

5-5169

**Figure 10. K2 Interface LT and NT**

**K2 Interface Description** (continued)

**K2 Bits Description**

Table 4 summarizes the K2 interface bits which are common to all configurations. The K2 frame consists of eight octets of data. The first three octets contain the 18 bits of 2B+D data. Bits 5—8 of the third octet contain U frame and superframe timing (DF). Octet 4 (S1) is reserved for future use and should always be set to 1. Octets 5, 6, and 7 are directly mapped to the U-inter-

face M (UM) maintenance bits which are transparent to the device, except the adea bit. Octet 8 is for device status (DS) and device control (DC). These bits must be manipulated according to the T1.601 standard to obtain proper system-level operation.

Figure 11 describes the four different K2 interface formats for DO and DI at the NT and LT. Tables 5—14 describe the position and meaning of the various bits on the K2 interface. Tables 15 and 16 show the active logic level for these bits, their value during reset/idle, and their value when the transceiver is operational.

**Table 4. K2 Interface Serial Data Bit Map**

Bits marked with 1 should always be set to a 1. Bits marked as Rxx are reserved by T1.601 and should be set to a 1.

Time ----->									
Symbol	Octet	Bit 1	Bit 2	Bit 3	Bit 4	Bit 5	Bit 6	Bit 7	Bit 8
B1	1	B11	B12	B13	B14	B15	B16	B17	B18
B2	2	B21	B22	B23	B24	B25	B26	B27	B28
D	3	D1	D2	1	1	1	1	1	1
DF	3	D1	D2	1	1	RSF	RF	TSF	TF
S1	4	1	1	1	1	1	1	1	1
UM1	5	a1	a2	a3	dm	i1	i2	i3	i4
UM2	6	i5	i6	i7	i8	act	R <sub>1,5</sub>	R <sub>1,6</sub>	*
UM3	7	R <sub>2,5</sub>	*	*	*	*	R <sub>6,4</sub>	*	*
DS	8	nebe	xact	†	1	oof	1	rsksi	1
DC	8	ccrc	istp	lpbk	afrst	ldea	1	sksi	xpcy

\* Items differ dependent upon NT or LT mode.

† Don't care.



**K2 Interface Description** (continued)

**Table 5. B1, B2, D, and S1 Octets (Overview)**

Octet	Octet #	DO/DI	Bit 1	Bit 2	Bit 3	Bit 4	Bit 5	Bit 6	Bit 7	Bit 8
B1	1	DO/DI	B11	B12	B13	B14	B15	B16	B17	B18
B2	2	DO/DI	B21	B22	B23	B24	B25	B26	B27	B28
D	3	DI	D1	D2	1	1	1	1	1	1
DF	3	DO	D1	D2	1	1	RSF	RF	TSF	TF
S1	4	DO/DI	1	1	1	1	1	1	1	1

**Table 6. B1, B2, D, and S1 Octets (Functions)**

Octet	Bit #	Symbol	Name/Function
B1	1—8	B11—B18	<b>B1 Octet.</b> The B1 octet is used for transferring basic access channel B1. B11 is the first bit of the B1 octet sent or received.
B2	1—8	B21—B28	<b>B2 Octet.</b> The B2 octet is used for transferring basic access channel B2. B21 is the first bit of the B2 octet sent or received.
D	1—2	D1, D2	<b>D Octet.</b> The two D-channel bits are transmitted in the first 2 bits of the D octet. D1 is the first bit of the D pair sent or received.
DF	5	RSF	<b>Receive Superframing.</b> 12.5% duty cycle at an 83.333 Hz rate (12 ms). 0—Last 84 K2 frames of the superframe. 0 to 1—Marks the first K2 frame of 2B+D data. Corresponds to the first 2B+D data of the U superframe. 1—First 12 K2 frames and during reset state up to point T6 or T7.
DF	6	RF	<b>Receive Framing.</b> 50% duty cycle at a 666.66 Hz rate (1.5 ms). 0—Last six K2 frames of the U frame. 0 to 1—Marks every 12th K2 frame of 2B+D data. Corresponds to the first 2B+D data of the U frame. 1—First six K2 frames and during reset state up to point T6 or T7.
DF	7	TSF	<b>Transmit Superframing.</b> 12.5% duty cycle at an 83.333 Hz rate (12 ms). 0—Last 84 K2 frames of the superframe 0 to 1—Marks the first K2 frame of 2B+D data. Corresponds to the first 2B+D data of the U superframe. 1—First 12 K2 frames and during reset state up to point T6 or T7.
DF	8	TF	<b>Transmit Framing.</b> 50% duty cycle at a 666.66 Hz rate (1.5 ms). 0—Last six K2 frames of the U frame. 0 to 1—Marks every 12th K2 frame of 2B+D data. Corresponds to the first 2B+D data of the U frame. 1—First six K2 frames and during reset state up to point T6 or T7.
S1	1—8	S11—S18	<b>S1 Octet.</b> All bits of the S1 octet are set to 1.

**K2 Interface Description** (continued)**Table 7. UM1 and UM2 Octets—eoc Bits (Overview)**

Octet	Octet #	DO/DI	Bit 1	Bit 2	Bit 3	Bit 4	Bit 5	Bit 6	Bit 7	Bit 8
UM1	5	DO/DI	a1	a2	a3	dm	i1	i2	i3	i4
UM2	6	DO/DI	i5	i6	i7	i8	See next page.			

**Table 8. UM1 and UM2 Octets—eoc Bits (Functions)**

Additional details on eoc bits can be found in T1.601.

Octet	Bit #	Symbol	Name/Function
UM1, 2	1—8, 1—4	eoc	<b>eoc Bits.</b> The eoc bits are passed transparently from the U-interface to the K2 interface and from the K2 to the U-interface. The transceiver maintains the eoc information at the K2 interface until a new block of eoc information is available.
UM1	1—3	a1—a3	<b>eoc Address.</b> 000—NT address. 001—LT to NT intermediate address. 010—110—LT to NT, decrement address and pass on. 001—101—NT to LT, increment address and pass on. 111—Broadcast address.
UM1	4	dm	<b>Data or Message Indicator.</b> 0—Data. 1—Message.
UM1, 2	5—8, 1—4	i1—i4, i5—i8	<b>Information.</b> eoc channel message information. 01010000—Operate 2B+D loopback. 01010001—Operate B1 channel loopback. 01010010—Operate B2 channel loopback. 01010011—Request corrupt crc. 01010100—Notify of corrupted crc. 11111111—Return to normal. 00000000—Hold state. 10101010—Unable to comply. Refer to T1.601 for codes which are reserved, nonstandard, or internal network use.



**K2 Interface Description** (continued)

**Table 9. UM2 and UM3 Octet—UCS Bits (Overview)**

Octet	Octet #	DO/DI	Bit 1	Bit 2	Bit 3	Bit 4	Bit 5	Bit 6	Bit 7	Bit 8
UM2	6	DOLT/[DI <sub>NT</sub> ]	See previous page.				act	R <sub>1,5</sub>	R <sub>1,6</sub>	ps1
UM2	6	DO <sub>NT</sub> /[DI <sub>LT</sub> ]	See previous page.				act	R <sub>1,5</sub>	R <sub>1,6</sub>	[a]dea
UM3	7	DOLT/[DI <sub>NT</sub> ]	R <sub>2,5</sub>	[r]febe	ps2	ntm	cso	R <sub>6,4</sub>	sai	nib
UM3	7	DO <sub>NT</sub> /[DI <sub>LT</sub> ]	R <sub>2,5</sub>	[r]febe	R <sub>3,4</sub>	R <sub>4,4</sub>	R <sub>5,4</sub>	R <sub>6,4</sub>	uoa	aib

**Table 10. UM2 and UM3 Octet—UCS Bits (Functions)**

Octet	Bit #	Symbol	Name/Function
UM2	5	act	<b>Activation.</b> Passed transparently from the K2 to the U-interface and from the U to the K2 except during a start-up when it is forced to a 0 on the K2. 0—Pending activation. 1—Ready to transmit information.
UM2	6, 7	R <sub>x,y</sub>	<b>Reserved Bits.</b> Passed transparently from the K2 to the U-interface and from the U to the K2. Transmit should always be set to a 1.
UM2	8	ps1 (DOLT/ DI <sub>NT</sub> )	<b>Power Status #1.</b> Passed transparently from the K2 to the U-interface at the NT and from the U to the K2 at the LT. 0—Primary power out. 1—Primary power is normal. When both ps1 and ps2 are 0, this indicates a dying gasp.
UM2	8	[a]dea (DO <sub>NT</sub> / DI <sub>LT</sub> )	<b>[AND with] Deactivate.</b> In LT mode, this bit is used in conjunction with the Idea bit from the K2, then passed to the U-interface as the transmitted dea bit. In NT mode, this bit is passed transparently from the U to the K2 interface. Allows deactivation warning to the far-end NT without deactivating the local transceiver. 0—Deactivation warning. 1—Normal.
UM3	1, 6	R <sub>x,y</sub>	<b>Reserved Bits.</b> Passed transparently from the K2 to the U-interface and from the U to the K2 interface. Transmit should always be set to a 1.
UM3	2	[r]febe	<b>[Receive] Far-End Block Error.</b> If the MODE1 = 1, rfebe is ANDed with nebe and the result is sent out as the U-interface febe bit. If the MODE1 = 0, rfebe is passed transparently from the K2 (DOLT/DI <sub>NT</sub> ) to the U-interface febe bit. For either setting of MODE1, the febe bit is passed transparently from the U-interface to the K2 interface. 0—Error indication passed to the originator. 1—No error, or feature is not utilized.
UM3	3	ps2 (DOLT/ DI <sub>NT</sub> )	<b>Power Status #2.</b> Passed transparently from the K2 to the U-interface at the NT and from the U to the K2 at the LT. 0—Secondary power out. 1—Secondary power normal. When both ps1 and ps2 are 0, this indicates a dying gasp.
UM3	4	ntm (DOLT/ DI <sub>NT</sub> )	<b>NT Test Mode.</b> Passed transparently from the K2 to the U-interface at the NT and from the U to the K2 at the LT. 0—The NT is currently in a test mode. 1—Normal.

T7264 U-Interface 2B1Q Transceiver

**K2 Interface Description** (continued)

**Table 10. UM2 and UM3 Octet—UCS Bits (Functions)** (continued)

Octet	Bit #	Symbol	Name/Function
UM3	5	cs0 (DOLT/ DINT)	<b>Cold Start Only.</b> Passed transparently from the K2 to the U-interface at the NT and from the U to the K2 at the LT. 0—Cold and warm start capability. 1—Cold start only.
UM3	3, 4, 5	R <sub>x,y</sub> (DON <sub>T</sub> /DIL <sub>T</sub> )	<b>Reserved Bits.</b> Passed transparently from the K2 to the U-interface (DIL <sub>T</sub> ) and from the U to the K2 interface (DON <sub>T</sub> ). Transmit should always set to a 1.
UM3	7	sai (DIN <sub>T</sub> / DOLT)	<b>S/T-Interface Activity Indicator.</b> Passed transparently from the K2 to the U-interface at the NT and from the U to the K2 interface at the LT. 0—No activity at the S/T-interface. 1—Activity (INFO1 or INFO3) at S/T-interface.
UM3	7	uoa (DIL <sub>T</sub> / DON <sub>T</sub> )	<b>U-Interface Only Activation.</b> Passed transparently from the K2 to the U-interface at the LT and from the U to the K2 interface at the NT. 0—Request S/T deactivation at the NT. 1—Allow S/T activation at the NT.
UM3	8	nib (DIN <sub>T</sub> / DOLT)	<b>Network Indicator Bit.</b> Passed transparently from the K2 to the U-interface at the NT and from the U to the K2 interface at the LT. Reserved for network use. Normally set to 1 in customer premises equipment.
UM3	8	aib (DIL <sub>T</sub> / DON <sub>T</sub> )	<b>Alarm Indication Bit.</b> Passed transparently from the K2 to U-interface at the LT and from the U to the K2 interface at the NT. 0—Failure of intermediate 2B+D transparent element. 1—Transmission path is established between NT and local exchange.

**Table 11. DS Octet (Overview)—Device Status**

Octet	Octet #	DO/DI	Bit 1	Bit 2	Bit 3	Bit 4	Bit 5	Bit 6	Bit 7	Bit 8
DS	8	DO	nebe	xact	—	1	oof	1	rsksi	1

**Table 12. DS Octet (Functions)—Device Status**

Octet	Bit #	Symbol	Name/Function
DS	1	nebe	<b>Near-End Block Error.</b> 0—crc error detected in previously received U frame. 1—Normal.
DS	2	xact	<b>Transceiver Active.</b> 0—Transceiver in reset state. 0 to 1—Detection of a tone or istp = 0. 1—Transceiver active. 1 to 0—On reset, 480 ms after loss of sync or deactivation.
DS	3	—	<b>Undefined.</b> May be either a 1 or a 0.
DS	4, 6, 8	—	<b>Reserved.</b> In normal operation, these bits are 1.
DS	5	oof	<b>Out of Frame.</b> 0—Out of frame. 1 to 0—Initiates the 480 ms loss of synchronization timer. 1—Normal.
DS	7	rsksi	<b>Reflected System-to-K2.</b> This bit reflects the value of the sksi bit received over the K2 interface.

## K2 Interface Description (continued)

Table 13. DC Octet (Overview)

Octet	Octet #	DO/DI	Bit 1	Bit 2	Bit 3	Bit 4	Bit 5	Bit 6	Bit 7	Bit 8
DC	8	DI	ccrc	istp	lpbk	afrst	Idea	1	sksi	xpcy

Table 14. DC Octet (Functions)

Octet	Bit #	Symbol	Name/Function
DC	1	ccrc	<b>Corrupt Cyclic Redundancy Check.</b> This bit is used to corrupt the crc information transmitted by the transceiver to the U-interface. 0—Corrupt crc generation as long as bit is low. 1—Generate correct crc (normal).
DC	2	istp	<b>Initiate Start-Up.</b> This bit is used to notify the transceiver of an activation request. Should be set to a 1 during loopback. If xact = 1, istp is ignored; if xact = 0: 0—Initiate start-up (activation request). 1—Reset state (transceiver inactive).
DC	3	lpbk	<b>Local Loopback.</b> 0—Loopback. 1—Normal. Loop back the complete 160 kbits/s U-interface bit stream at the analog output. Loopback turns off echo canceler and reconfigures the descrambler. Device should be reset and line disconnected before loopback test; istp should be set to a 1 during loopback.
DC	4	afrst	<b>Adaptive Filter Reset.</b> 0—Normal. 1—Reset. 2B+D and UM set equal to 1 on DO. Reset halts loop transmission and clears the transceiver's adaptive filter coefficients, overriding all other transceiver control signals. This provides the same functionality as the RESET pin on the T7264, except F to MTC synchronization (LT) is not lost.
DC	5	Idea	<b>Local Deactivation.</b> 0 — Normal. 1 — Deactivate. DO 2B+D and UM set equal to 1. Upon receiving Idea = 1 from the system device, the transceiver will save adaptive filter coefficients. In the LT, the device sends three or four U superframes of dea = 0, then ceases transmission and enters the idle state. In the NT, the device deactivates upon signal loss and enters the idle state. In the NT, Idea should be set before the loss of signal (on second dea = 0) and held until xact goes low for proper deactivation.
DC	6	—	<b>Reserved.</b> For normal operation, this bit must be set to 1.
DC	7	sksi	<b>System-to-K2.</b> This bit may be set high or low without affecting the state of the transceiver. sksi is reflected back from the T7264 across the K2 interface by means of the rsksi bit.
DC	8	xpcy	<b>Transparency.</b> 0—Transparent 2B+D. 1—LT mode 2B+D = 0 transmitted across the U-interface. 1—NT mode 2B+D = 1 transmitted across the U-interface. This bit only affects the data transmitted on the U-interface. The U-to-K2 interface always remains transparent after start-up.

T7264 U-Interface 2B1Q Transceiver

**K2 Interface Description** (continued)

**K2 Bit Levels**

**Table 15. K2 Data Out (DO) Bit Levels**

(+) Active = 1 (T) Transparent  
(-) Active = 0 (P) Pulsing

Bit Name	Description	True Level	Reset/Idle	Operational
<b>U-Interface Related</b>				
B1, B2	ISDN 64 kbits/s B1, B2 Octet		1	T
D	ISDN 16 kbits/s D Bits		1	T
RSF, TSF	Receive/Transmit Superframe	+	1	P
RF, TF	Receive/Transmit Frame	+	1	P
<b>UM Bits</b>				
eoc	eoc addr, d/m, and info bits	+	1	T
act	Activate	+	0	1
dea	Deactivate	-	1	1
ps1, ps2	Primary/Sec. Power Status	+	1	1
febe	Far-end Block Error	-	1	1
ntm	NT in Test Mode	-	1	1
cso	Cold Start Only	+	1	0 or 1
sai	S/T Activity Indicator	+	1	1
uoa	U Only Activation	-	1	1
nib	Network Indicator Bit	-	1	1
aib	Alarm Indication Bit	-	1	1
R	Reserved	-	1	1
<b>DS Bits</b>				
nebe	Near-end Bit Error	-	1	1
xact	Transceiver Active	+	0	1
oof	Out of Frame	-	0	1

**Table 16. K2 Device Control (DC) Bit Levels**

(+) Active = 1 (x) Either 1 or 0  
(-) Active = 0

Bit Name	Description	True Level	Reset/Idle	Operational
ccrc	Corrupt the Outgoing crc	-	x	1
istp	Initiate Start-up	-	1	0 then x
lpbk	Loopback	-	1	1
afrst	Reset	+	1 then x	0
ldea	Local Deactivate	+	1 then x	0
xpcy	Transparency	-	1	0

### U-Interface Description

Data is transmitted over the U-interface in 240-bit groups called U frames. Each U frame consists of an 18-bit synchronization word (ISW or SW), 12 blocks of 2B+D data (216 bits), and six overhead bits (M). A U-interface superframe consists of eight U frames grouped together. The beginning of a U superframe is indicated by the inverted sync word (ISW). The six overhead bits from each of the eight U frames, when taken together, form the 48 M bits. The following diagram shows how U frames, superframes, and M bits are mapped.

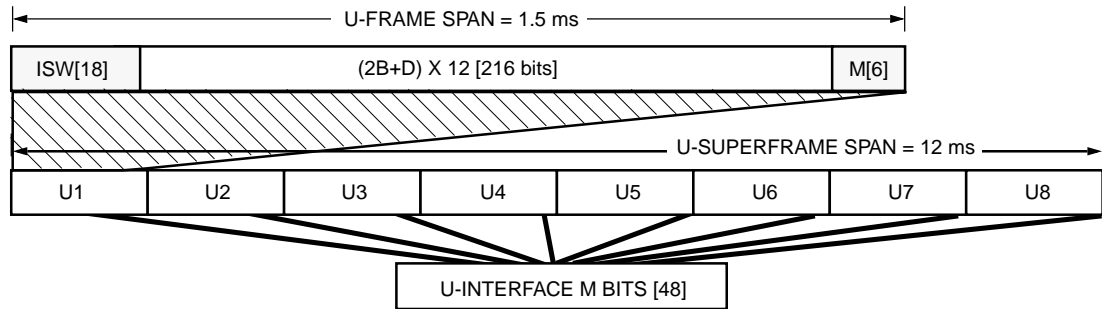

5-5171

Figure 12. U-Interface Frame and Superframe

Of the 48 M bits, 24 bits form the embedded operations channel (eoc) for sending messages from the LT to the NT and responses from the NT to the LT. There are two eoc messages per superframe with 12 bits per eoc message (eoc1 and eoc2). Another 12 bits serve as control and status bits (UCS). The last 12 bits form the cyclic redundancy check (crc) which is calculated over the 2B+D data and the M4 bits of the previous superframe. Figure 13 shows the different groups of bits in the superframe.

BIT #	1—18	19—234	235	236	237	238	239	240
FRAME #	Sync	12(2B+D)	M1	M2	M3	M4	M5	M6
1	ISW	2B+D	eoc1			CONTROL & STATUS (UCS)		
2								
3			eoc2			crc		
4								
5								
6								
7								
8								

5-5172

Figure 13. U-Interface Superframe Bit Groups

U-Interface Description (continued)

Table 17. U-Interface Bit Assignment

Bit #	1—18	19—234	235	236	237	238	239	240
Frame #	Sync	12(2B+D)	M1	M2	M3	M4	M5	M6
1	ISW	2B+D	eOCa1	eOCa2	eOCa3	act	R1, 5	R1, 6
2	SW	2B+D	eOCdm	eOCi1	eOCi2	dea (ps1)*	R2, 5	febe
3	SW	2B+D	eOCi3	eOCi4	eOCi5	R3, 4 (ps2)*	crc1	crc2
4	SW	2B+D	eOCi6	eOCi7	eOCi8	R4, 4 (ntm)*	crc3	crc4
5	SW	2B+D	eOCa1	eOCa2	eOCa3	R5, 4 (cso)*	crc5	crc6
6	SW	2B+D	eOCdm	eOCi1	eOCi2	R6, 4	crc7	crc8
7	SW	2B+D	eOCi3	eOCi4	eOCi5	uoa (sai)*	crc9	crc10
8	SW	2B+D	eOCi6	eOCi7	eOCi8	aib (nib)*	crc11	crc12

\* LT(NT). Values in parentheses () indicate meaning at the NT.

K2 Functional Description

The K2 interface provides the mechanism for transferring data and control information between the system and the T7264. A K2 frame consists of eight DO octets and eight DI octets which occur every 125 μs (every frame sync). Figure 14 shows the K2 frame structure.

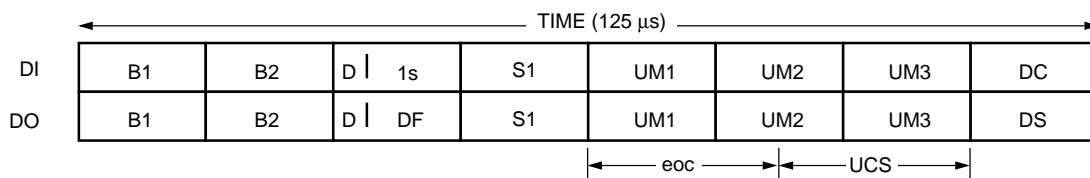

5-5173

Figure 14. K2 Octet Description

Figure 15 shows the points of origination and destination of bits on the K2 and U-interfaces at the LT and NT.

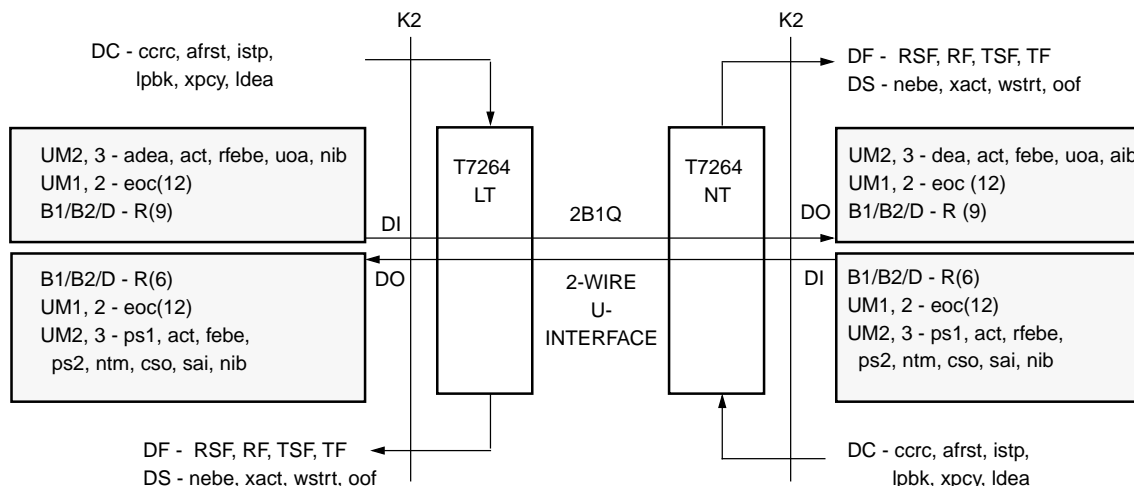

5-5174

Figure 15. K2 Functional Description

### K2 Functional Description (continued)

The U superframe and the K2 superframe both occur once every 12 ms. The U frame consists of 240 bits, with eight U frames per superframe, transferred at a data rate of 160 kbits/s. The K2 superframe consists of 96 K2 frames transferred at a data rate of 512 kbits/s.

In mapping the K2 to U, the blocks of 2B+D data, which occur once every K2 frame, are accumulated within the T7264 and are output in groups of twelve blocks per U frame onto the U-interface. The last 6 bits of the D octet and the S1 octet are unused on DI. While every K2 frame has bits allocated for eoc messages, only two messages per U superframe are needed. K2 frame number 11 (K11) provides the data for the first eoc message on the U-interface, and K2 frame K59 provides the data for the second eoc message. The other 94 K2 frames are unused. Every K2 frame also has bits allocated for UCS data; however, only a single set of UCS data is needed in a U superframe. K2 frame number K11 provides the UCS data while the other 95 K2 frames are unused. The crc is automatically generated by the T7264 and presented to the U-interface. The DC octet is used to transfer control data to the T7264 and is sampled every K2 frame.

In mapping the U to K2, the 2B+D data, which occur in groups of 216 bits (12 times [2B+D]), are accumulated within the T7264 and output as one 2B+D block per K2 frame. The last 4 bits of the D octet provide indication

onto the K2 interface about when data transferred on the K2 interface corresponds to data transferred on the U-interface for both transmit and receive. The eoc bits are collected by the T7264 and changed on the K2 interface twice per superframe on K2 frames K47 (held until K94) and K95 (held until K46). The UCS bits are collected by the T7264 and changed on the K2 interface once per superframe on K2 frame K95 (held until K94). The DS octet is used to transfer device status from the T7264 to the K2 interface. The crc is automatically calculated in the T7264, and a single bit (nebe) in the DS octet provides indication of a crc error.

### K2 Framing Bits

The four DF bits (the last 4 bits of the D octet on DO) indicate when the 2B+D data from the K2 interface and U-interface correspond. A system can monitor these signals to determine when the T7264 is transmitting or receiving specific data. RSF and TSF mark the first frame (K0) of a superframe. RF and TF add resolution in identifying the start of each U frame (every twelfth K2 frame). Figure 16 shows when eoc and UCS data is transferred to and from the K2 interface. It also indicates the occurrence of the RSF, TSF, RF, and TF bits. Notice that the DI and DO superframes are not aligned, and therefore RSF and TSF occur at different times.

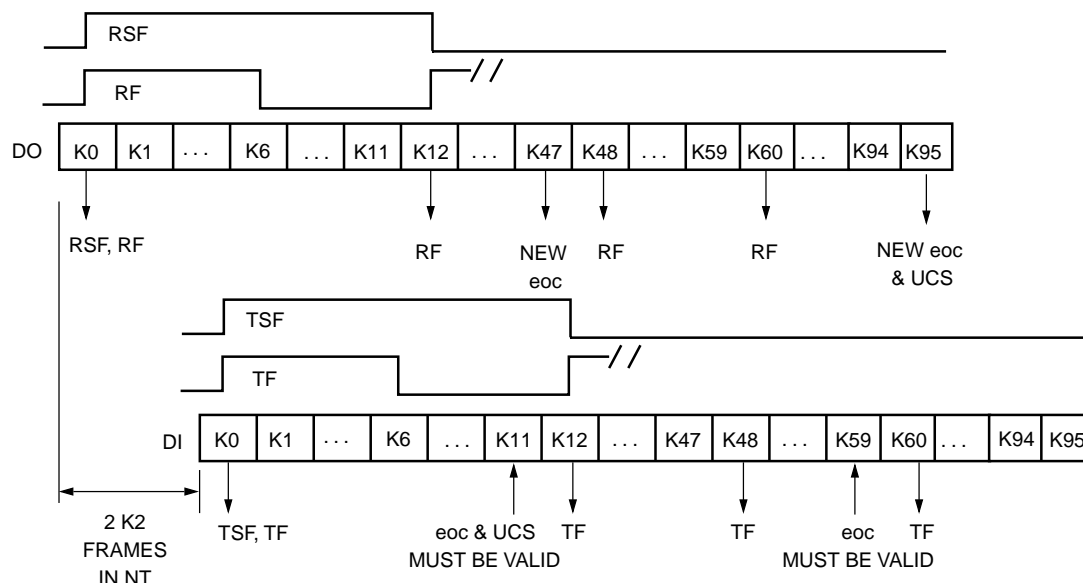

Figure 16. K2-to-U Mapping

**K2 Functional Description** (continued)

Figure 17 shows how the U-interface bits are grouped into eoc1, eoc2, UCS, and crc bits. It also shows how these bit groups are mapped from the U-interface to the K2 interface.

BIT #	1—18	19—234	235	236	237	238	239	240
FRAME #	SYNC	12(2B+D)	M1	M2	M3	M4	M5	M6
1	ISW*	U - 2B+D K - B1, B2, D  K0, K1, ... K95	U - eoc1 K - UM1 & UM2 (#1—4) INPUT K11 OUTPUT K47—K94			U - CONTROL & STATUS (UCS) K - UM2 (#5—8) & UM3 INPUT K11 OUTPUT K95—K94		
2	U - SW K - RF, TF OUTPUT K0, K12, K24, ... K84		U - eoc2 K - UM1 & UM2 (#1—4) INPUT K59 OUTPUT K95—K46					
3			U - crc K - OUTPUT DS - #1 (nebe) K - INPUT DC - #1 (ccrc)					
4								
5								
6								
7								
8								

5-5176

\* The U-inverted sync word (ISW) is mapped to the K2 interface as the receive superframe (RSF) bit and the transmit superframe (TSF) bit. The occurrence of these bits defines the first K2 frame.

**Figure 17. U-to-K2 Mapping**

**K2 eoc and Loopback Response Timing**

Each U frame contains 12 2B+D data blocks. These blocks are jitter accommodated and synchronized within the T7264 and output on the K2 interface. This introduces delay between the U-interface and the K2 interface. The receive and transmit framing on the U-interface do not occur at the same time. The ANSI standard specifies that the delay from U input to U output in the NT is 0.75 ms (6 K2 frames). The relationship between the K2 frame sync and the U-interface frame can change each time the device frames up.

The timing delay from receive to transmit affects the eoc timing as follows: The eoc is made available on the K2 interface at DO K2 frames K47 and K95, and it is sampled on DI K2 frames K59 and K11. This 11-frame difference plus the two-frame delay discussed above allows a total of 13 K2 frames (1625 μs) for the system to process the eoc information and respond. Thus, the system is guaranteed to have at least 1625 μs to respond to an eoc message. Figure 18 shows the received and transmitted K2 frame in the NT.

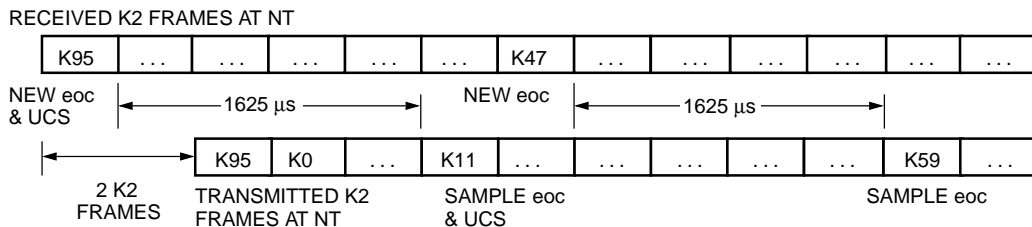

5-5177

**Figure 18. K2 Response Timing**



## K2 Functional Description (continued)

### K2 Device Status and Control Bits

The T7264 device status bits are transmitted over the K2 interface in the DS octet. The status information includes the nebe, xact, and oof bits which are used to determine the status of the line interface and to control the activate/deactivate state machine.

The T7264 device control bits are transmitted over the K2 interface in the DC octet. The control information includes the ccrc, istp, lpbk, afrst, Idea, and xpcy bits which provide the control necessary to implement the activation/deactivation state machine.

Tables 18 and 19 show how the DC bits are sampled and when the DS bits are available. Note that a Y in the column marked Hyst (hysteresis) indicates that the validation occurs on both entry and exit from the condition. An N in the Hyst column indicates that the validation occurs only on entry into that condition. For validation, a signal must be present for three consecutive K2 frames.

In LT mode, setting the Idea (local deactivation) bit causes the transceiver to send 3 or 4 superframes of dea = 0 across the U-interface, save the adaptive filter coefficients, and cease transmission.

In the NT mode, the Idea bit is used to ensure that the transceiver is capable of a warm start on the next activation; however, the transceiver must be given advance warning prior to loss of signal. This should be done by filtering dea = 0 for two superframe occurrences prior to setting Idea = 1. This causes the transceiver to freeze echo canceler coefficients. The transceiver then either deactivates upon detection of loss of signal or resumes training the echo canceler if Idea = 0 is received instead of detecting loss of signal.

In both LT and NT modes, the lpbk (local loopback) bit is used to request a local loopback within the transceiver from the K2 input (DI) to the K2 output (DO). During loopback, the transceiver turns off the echo canceler (disables the canceler output from the summing node) and reconfigures the descrambler. To perform loopback, set afrst = 1 and lpbk = 1, disconnect the U-interface metallic connection to the loop plant, then set afrst = 0 and lpbk = 0. Loopback has become valid when oof = 1. In order to terminate the loopback, set afrst = 1 and lpbk = 1. Reconnect the loop plant, then set afrst = 0. During the entire loopback test, istp = 1 and xpcy may be either 0 or 1.

**Table 18. DC Octet Description (Control)**

Control (DC)	Description	Hyst	Timing
ccrc bit	Corrupt crc	N	Sample K2 frames 9, 10, 11 for three consecutive ccrc = true K2 frames. Continues to corrupt until the condition goes away.
istp	Initiate Start-up	N	Sample for three consecutive K2 frames to validate.
Idea	Local Deactivate	Y	Sample for three consecutive K2 frames to validate.
xpcy	Transparency	Y	Sample for three consecutive K2 frames to validate.
afrst	Reset	Y	Sample for three consecutive K2 frames to validate.
lpbk	Loopback	Y	Sample for three consecutive K2 frames to validate.

**Table 19. DS Octet Description (Status)**

Status (DS)	Description	Timing
nebe	Near-end Block Error	Presented to K2 interface on frame K95 to K94.
xact	Transceiver Active	Presented to K2 interface as it occurs.
oof	Out of Sync	Presented to K2 interface as it occurs.

**K2 Functional Description** (continued)**The adea Bit**

The adea bit is only available when the MODE0 pin is set to 1 (LT mode). Setting adea = 0 causes the LT to set dea = 0 on the U-interface without deactivating itself. By contrast, setting Idea = 1 at the LT causes the LT to set dea = 0 on the U-interface, save adaptive filter coefficients, and deactivate itself after sending dea = 0 for three consecutive U superframes.

In loop configurations with multiple U-interfaces, as shown in T1.601, adea is used to propagate dea = 0 beyond the local link (the link between the LT in an ISDN serving switch to the next NT downstream-type element of the loop) and can be used to deactivate a nonlocal link without deactivating the local link.

Table 20 shows the effects of the adea and Idea bits at the LT.

**Table 20. adea, Idea, and dea Function**

adea at LT	Idea at LT	Action
0	0	dea = 0 is sent downstream, but no local deactivation occurs.
X	1	dea = 0 is sent downstream for 3 or 4 superframes, echo canceler coefficients are frozen, and transmission ceases.
1	0	dea = 1 is sent downstream (normal operation).

## K2 Functional Description (continued)

### The nebe, febe, rfebe, and ccrc Bits

Errors in the received 12-bit crc from the U-interface are indicated via the nebe (near-end block error) bit. The nebe bit is a local status bit that is set to 0 each time a crc error is detected. Errors in transmitted crc can be forced by setting the ccrc (corrupt crc) bit low. Because the crc error detection and corruption is handled via the nebe and ccrc bits, there is no need to have direct control or access to the 12 crc bits via the K2 interface.

Normally, the T7264 automatically reflects the nebe bit back to the far end as the ANSI-defined febe (far-end block error) bit. The MODE1 pin (pin 11) and rfebe bit can be used to alter the interaction between nebe and febe as shown in Figure 19. Normally, MODE1 and rfebe are HIGH, so febe is the direct result of the current state of nebe. Now rfebe can be directly used to control the state of febe.

The intended application for rfebe and MODE1 is one having multiple U links as shown in T1.601-1992, Figure E1. In this application, a performance monitoring approach called path performance monitoring can be used. This treats all links between the NT and LT as one complete link, or path. Thus, any febes or nebes that occur at an intermediate element should be propagated to an endpoint. In this way, the febe and nebe counts at the endpoints represent the performance of the system as a whole.

Figure 20 shows how a multilink system with one intermediate element (IE) could use MODE1, rfebe, nebe, febe, and ccrc to propagate crc errors to the endpoints. For simplicity, this figure represents only one direction of propagation of nebe and febe, namely nebes propagated toward the LT and febes propagated toward the NT. This circuitry would be duplicated in the opposite direction to form a complete system. At the endpoints, MODE1 = 1 and rfebe = 1, so nebe and febe behave normally. At IE, MODE1 = 0 so that rfebe, rather than nebe, controls the state of febe toward the far end. For clarity, the effect of MODE1 is shown as a coil control for an SPDT relay that selects either nebe or Vcc as the upper input to the AND gate.

First, consider the case of a nebe occurring at the IE's LT-mode T7264. This means that a crc error occurred from NT to IE. The IE's K2 interface logic connects nebe directly to the ccrc bit of the NT-mode T7264 to force a ccrc error toward the LT. This will now show up as a nebe at the LT, effectively propagating nebe from IE to LT.

Now, at the LT, the nebe is reflected back toward the IE as a febe. At the IE, the K2 interface logic connects febe directly to the rfebe bit of the LT-mode T7264. This generates a febe from IE to NT, completing the path for the original crc error. Thus, the result of an error from NT to IE is a nebe reported at the LT and a febe reported at the NT. This illustrates how the two links and the IE are treated as a single entity from a performance monitoring standpoint.

**K2 Functional Description** (continued)

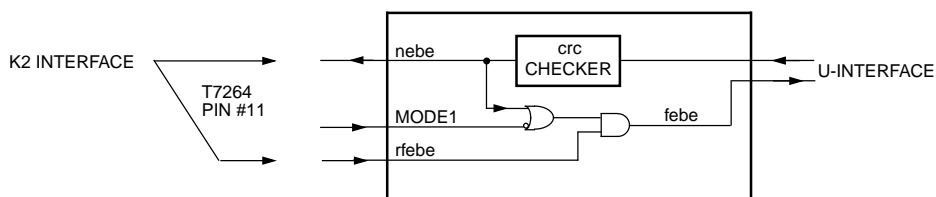

5-5178a

**Figure 19. T7264 nebe/febe/crc Block Diagram**

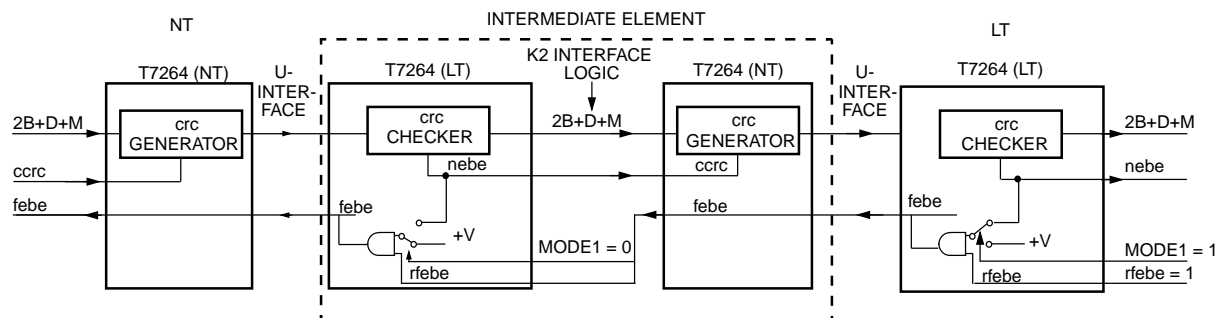

5-5179a

**Figure 20. Use of rfebe in a Multilink Configuration**

**NT or LT Operation**

The MODE0 pin determines whether the device is being used in an LT system as the originator of the U-interface signals or in the NT mode as the terminator of the U-interface signal. Table 21 is provided as a reference to show the different functions of the chip in NT and LT modes.

**Table 21. MODE0 Pin Functionality**

LT (MODE0 = 1)	NT (MODE0 = 0)
U-interface timing derived from MTC	K2 timing derived from the U-interface
Transmit adea AND Idea for dea, uoa, aib	Transmit ps1, ps2, ntm, cso, sai, nib
U transmit-to-receive timing dependent upon line delay	U transmit-to-receive timing fixed at 0.75 ms
Idea stops transmission	Loss of signal stops transmission
LT scrambling algorithm	NT scrambling algorithm
LT start-up timing	NT start-up timing
TL tone generation	TN tone generation
TN tone recognition	TL tone recognition

## Minimal Example

The simplest application of the T7264 in an NT1 is to assume only cold starts and always return an unable-to-comply for the eoc message. In this situation, the K2 interface signals are configured as shown in Table 22.

**Table 22. Minimal Implementation**

Note that this is only an example and not a valid T1.601 configuration. However, it could be useful for laboratory testing.

Bit Name	Description	Minimal State	Description
B1, B2	ISDN 64 kbits/s B1, B2 Octet	T	Transparent
D	ISDN 16 kbits/s D Bits	T	Transparent
<b>Data In</b>			
a	Address	000	NT Address
dm	Data or Message	1	Message
i	Information	10101010	Unable to Comply
act	Activation	INFO3	Transceiver Active
ps1, ps2	Primary/Sec. Power Status	1	Always True
rfebe	Received Far-end Bit Error	1	Not Applicable
ntm	NT in Test Mode	1	Never Used
cso	Cold Start Only	1	Always Cold Start
R	Reserved	1	Never Used
<b>Data Out</b>			
dea	Deactivation	1	Ignore
ccrc	Corrupt the Outgoing crc	1	Never Used
istp	Initiate Start-up	0	Always Starting
lpbk	Loopback	1	Never Used
afrst	Reset (Adaptive Filter Reset)	0	Never Used— $\overline{\text{RESET}}$ Pin Used
ldea	Local Deactivation	0	Never Used—Always Active
xpcy	Transparency	NOT act	Received K2 act Bit

## T7264 U-Interface 2B1Q Transceiver

**Activation and the K2 Interface**

The signal definitions and start-up states (Table 23 and Figure 21) of the U-interface during activation are as required by T1.601. The T7264 handles these details automatically upon assertion of *istp* on the K2 interface or detection of a tone on the U-interface. Still, for some users it is useful to know what is happening at the K2 interface during the start-up sequence and how the system should be reacting. The following is an explanation of what happens during a typical start-up sequence. For simplification, it is assumed that the *uoa* and *sai* bits, defined in T1.601-1992, are held at 1 during start-up.

**1. From RESET to T6**

At each end, *xact* changes from 0 to 1 to indicate that an activation request has been issued at the near end (via *istp*) or a wake-up tone has been detected from the far end and the transceiver is beginning the start-up sequence. All other K2 bits are held in their reset state by the transceiver in the U-to-K2 direction at both the NT and the LT (see Table 15 for these RESET values). In the K2-to-U direction, the 2B+D and U overhead bits are internally overwritten by the transceivers. These bits should be initialized by the system to reflect their desired state at the time transparency is achieved. Table 23 lists the values of the overwritten U bits at various stages of activation.

**2. At T6**

At the NT, *oof* goes high causing 2B+D transparency from the U to the K2 interface at the NT transceiver. Note that the NT always frames up before the LT, due to the structure of the transceiver start-up algorithms. Before T6, the NT transceiver was forcing 2B+D data on the K2 interface to all 1s. After this, the 2B+D bits on the K2 interface contain whatever is being received at the NT's U-interface on the 2B+D channels from T4 until transparency is established (see Table 23 and Figure 21, signal SL2).

M bits in the downstream direction become transparent over the entire link. Prior to this, the NT transceiver was forcing all M bits to 1 in the downstream (U-to-K2) direction, except *act*, which was being forced to 0. In the downstream direction (K2-to-U) at the LT, M bits are already being passed transparently and have been since T4. At T6, *oof* = 1 at the NT causes the NT to start passing M bits transparently in the downstream direction.

M bits in the upstream direction become transparent at the NT transceiver (K2-to-U). Prior to this, the NT transceiver was internally overwriting the upstream M bits to all 1s per the ANSI standard (see Table 23 and Figure 21, signal SN2).

After detecting *oof* = 1, the NT can set its *act* = 1, then wait for *act* = 1 from the LT. The NT is still forcing 2B+D in the upstream direction to all 1s and continues to do so until:

- a) It receives *act* = 1 from the LT
- b) It receives an *eoc* loopback message from the LT

When either of the above occurs, the NT must set *xpcy* = 0, which enables 2B+D transparency in the upstream direction.

**3. At T7**

At the LT, *oof* goes high causing 2B+D transparency from the U to the K2 interface at the LT transceiver. Before T7, the LT transceiver was forcing 2B+D data on the K2 interface to all 1s. After this, the 2B+D bits on the K2 interface contain whatever is being received at the LT's U-interface on the 2B+D channels. This is all 1s initially, because the NT transceiver at the far end is forcing transmission of all 1s on the U-interface 2B+D channels from T1 until the transparency is established (see Table 23 and Figure 21, signal SN1—SN3).

M bits in the upstream direction become transparent over the entire link. Prior to this, the LT transceiver was forcing all the M bits to 1 in the upstream (U-to-K2) direction, except *act*, which was being forced to 0. In the upstream (K2-to-U) direction at the NT, M bits are already being passed transparently and have been since T6. At T7, *oof* = 1 at the LT causes the LT to start passing M bits transparently in the U-to-K2 direction and, thus, affects full M-bit transparency in the upstream direction.

Since the LT is receiving M4 bits from the NT, it can detect when the NT has changed its *act* bit from 0 to 1. After getting *act* = 1 three consecutive times from the NT, the LT may set its *xpcy* = 0 and *act* = 1, resulting in 2B+D transparency in the downstream direction over the entire link. Prior to this, the LT transceiver was internally overwriting the downstream 2B+D data to all 0s per T1.601.

### Activation and the K2 Interface (continued)

There is one case in which the LT never receives act = 1 from the NT. If the LT is connected to an NT1, which has no TE controlling it, the NT can never send act = 1. T1.601 (Section 6.4.6.6) states that transparency required to perform loopbacks must be provided when loopbacks are requested, even when the NT is not sending act = 1. In this case, the LT, once it has received oof = 1, must transmit the proper eoc message to enable the desired remote loopback. The NT1 must set its xpcy = 0 in response to the eoc loopback message. Upon receiving the echoed message from

the NT, the LT must set xpcy = 0. Now, transparency is established over the entire link without having set the act bits to 1.

Upon receiving act = 1 three consecutive times from the LT, or upon receiving an eoc loopback message as discussed above, the NT sets its xpcy = 0, affecting 2B+D transparency in the upstream direction over the entire link. Prior to this, the NT transceiver was internally overwriting the upstream 2B+D data to all 1s per T1.601. The link is now fully operational.

Table 23. Definitions of Signals During Start-Up

Signal	Sync Word (SW)	Superframe (ISW)	2B+D	M	Start	Stop	Time (Frames)
TN	±3*	±3*	±3*	±3*	†	†	6
SN1	Present	Absent	1	1	T1	T2	—
SN2	Present	Absent	1	1	T5	T6	—
SN3	Present	Present	Normal <sup>+</sup>	Normal	T6	‡	—
TL	±3*	±3*	±3*	±3*	†	†	2
SL1	Present	Absent	1	1	T3	T4	—
SL2	Present	Present	0	Normal	T4	T7	—
SL3	Present	Present	Normal <sup>†</sup>	Normal	T7	‡	—

\* Tones have alternating pattern of four +3s, followed by four -3s, and no SW.

† See Figure 21 for start and/or stop time of this signal.

‡ Signals SN3 and SL3 continue indefinitely (or until deactivation).

Notes:

TN, TL — Tones produced by NT or LT, respectively.

SNx, SLx — Pulse patterns produced by NT or LT, respectively.

Tx — Notation refers to transition instants defined in Figure 21.

Absent — Under superframe, this notation means that only SW is transmitted, not ISW.

Normal — Normal means that the M bits are transmitted onto the 2-wire line as required during normal operation (e.g., valid crc bits, eoc bits, and indicator bits are transmitted).

Normal<sup>+</sup> — Except to perform a loopback, 2B+D bits remain in the previous state (SN2 or SL2) until both act bits indicate full transparency of the B- and D-channels (i.e., the 2B+D bits of SN3 and SL3 must remain set to 1 and 0, respectively, until transparency is achieved at both ends of the DSL).

### Priority

Priorities exist for responding to several signals as follows:

1.  $\overline{\text{RESET}}$
2. afrst
3.  $\overline{\text{LOSS}}$
4. tone detection
5. istp
6. lpbk

## Activation and the K2 Interface (continued)

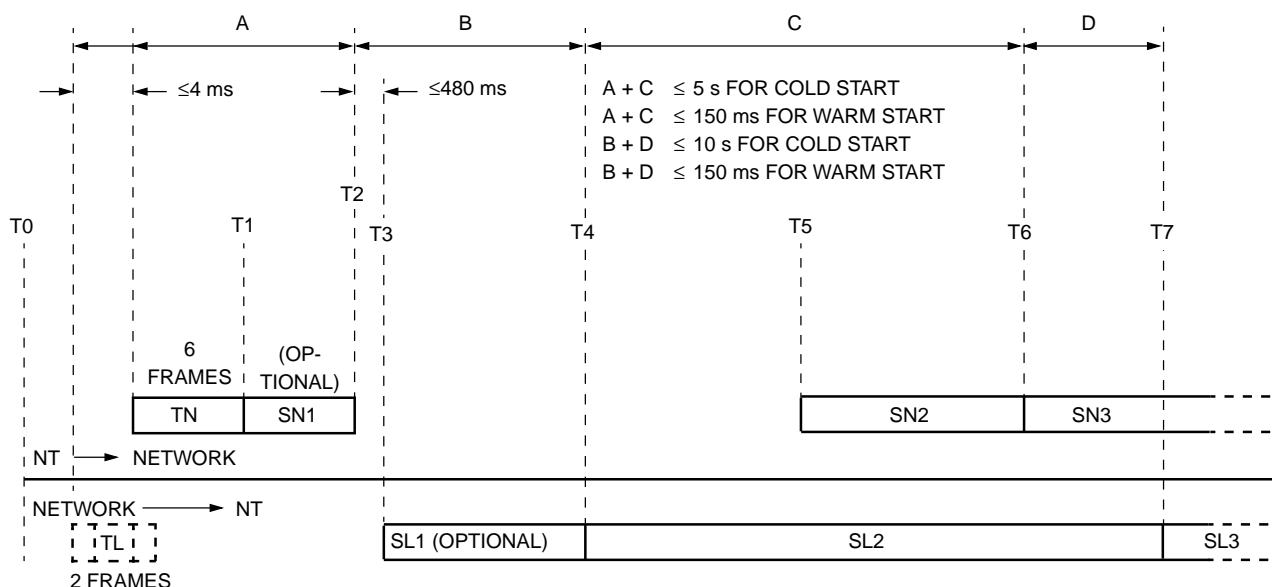

5-5180

## Notes:

- T0 Reset state.
- T1 Network and NT are awake.
- T2 NT discontinues transmission, indicating that the NT is ready to receive signal.
- T3 Network responds to termination of signal and begins transmitting signal toward the NT.
- T4 Network begins transmitting SL2 toward the NT, indicating that the network is ready to receive SN2.
- T5 NT begins transmitting SN2 toward the network, indicating that NT has acquired SW frame and detected SL2.
- T6 NT has acquired superframe marker, and is fully operational.
- T7 Network has acquired superframe marker, and is fully operational.

Figure 21. State Sequence for DSL Transceiver Start-Up

## Applications

The T7264 is intended for use in both switch and customer premises equipment including a central office (CO), a private branch exchange (PBX), a 2-wire to 4-wire converter (NT1), and terminal equipment (TE). The physical termination of the U-interface at the network end is referred to as the line termination (LT); the physical termination at the user end is referred to as the network termination (NT). Figure 22 shows a loop configuration using several U-interface devices at various locations.

The T7264 provides system access to the U loop through the K2 interface. The K2 interface is a TDM serial interface which provides access to 2B+D data, U-interface maintenance, and T7264 device control/status.

Figure 23 shows a 2-wire terminal application with the T7264 providing the U-interface. The T7270 provides the microprocessor with access to the individual octets of the K2 data stream. The B1 and B2 data could be transferred to either a codec for voice communications, such as the T7513A, or to an HDLC controller for data communications, such as the T7121. Another T7121 could provide microprocessor access to D-channel HDLC processing. The microprocessor would control initialization, activation/deactivation, D-channel processing, and maintenance functions.



**Applications** (continued)

Figure 24 shows a digital pair gain application with the T7264 providing the U-interface. In this system, the U-interface is used as a digital pipe to multiplex two analog voice lines onto the B channels. Thus, one twisted pair can provide two analog lines. The T7270 forms the interface between the microprocessor, the K2 bus, and the codecs. The T7121 can be used for HDLC formatting on the B or D channels to provide enhanced features. The divider provides the 2.048 MHz clock for the codecs, which are interfaced to the TSI via its CHI ports. The codecs and battery feeds provide the analog interface to the telephones.

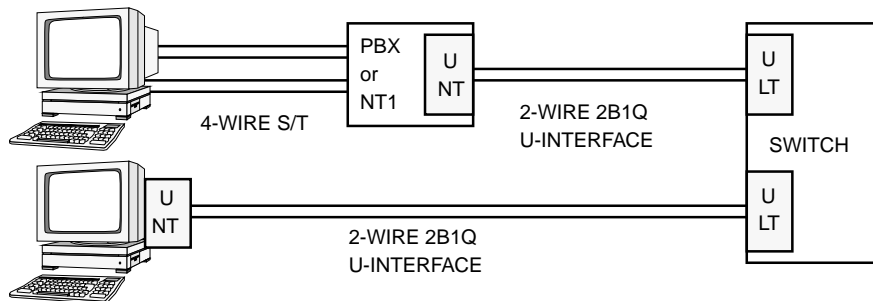

5-5181

**Figure 22. Loop Application**

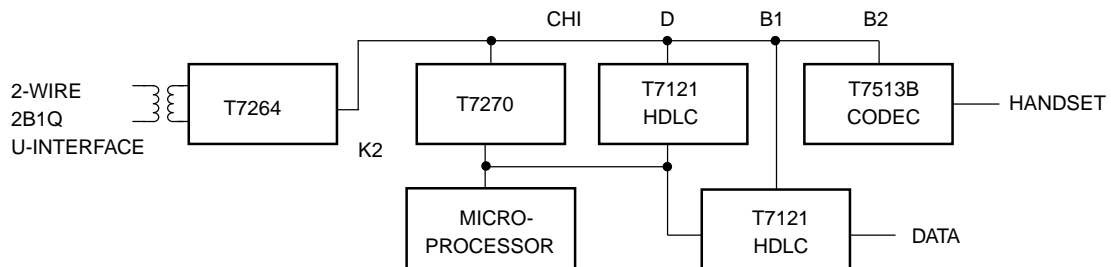

5-5182

**Figure 23. 2-Wire Terminal Application**

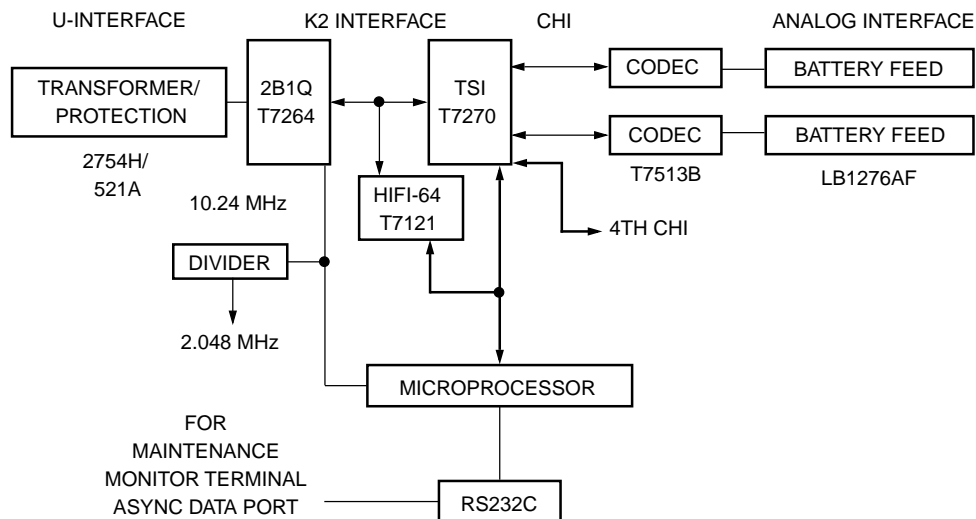

5-5183

**Figure 24. Digital Pair Gain Application**

T7264 U-Interface 2B1Q Transceiver

**Absolute Maximum Ratings**

Stresses in excess of the absolute maximum ratings can cause permanent damage to the device. These are absolute stress ratings only. Functional operation of the device is not implied at these or any other conditions in excess of those given in the operations sections of this data sheet. Exposure to absolute maximum ratings for extended periods can adversely affect device reliability.

Parameter	Min	Typ	Max	Unit
Storage Temperature	-55	—	125	°C
Lead Temp (soldering or bonding)	—	—	300	°C
Any Pin to GND	-0.5	—	6.5	V
Power Dissipation (package limit)	—	—	700	mW

**Handling Precautions**

Although protection circuitry has been designed into this device, proper precautions should be taken to avoid exposure to electrostatic discharge (ESD) during handling and mounting. Lucent employs a human-body model (HBM) and charged-device model (CDM) for ESD-susceptibility testing and protection design evaluation. ESD voltage thresholds are dependent on the circuit parameters used to define the model. No industry-wide standard has been adopted for the CDM. However, a standard HBM (resistance = 1500 Ω, capacitance = 100 pF) is widely used and, therefore, can be used for comparison. The HBM ESD threshold presented here was obtained by using these circuit parameters:

ESD Threshold Voltage	
Device	Voltage
T7264-ML	>500

**Recommended Operating Conditions**

Parameter	Symbol	Test Conditions	Min	Typ	Max	Unit
Ambient Temp	T <sub>A</sub>	V <sub>DD</sub> = 5 V ± 5%	-40	—	85	°C
Any V <sub>DD</sub>	V <sub>DD</sub>	—	4.75	5.0	5.25	V
GND to GND	V <sub>GG</sub>	—	-10	—	10	mV
Voltage Ref Capacitor	C <sub>VR</sub>	—	0.08	0.1	0.2	μF
Master Clock Frequency	MCLK	—	—	15.36	—	MHz
Master Clock Tolerance	MCLK	NT Mode LT Mode	-225* -225 + x*†	— —	225* 225 - x*†	ppm ppm
Master Clock Duty Cycle	MCLK	—	47†	—	53	%

\* To meet ANSI T1.601 free-run line rate requirement, NT tolerance is 100 ppm.

† x = tolerance of MTC.

## Electrical Characteristics

All characteristics are for a 15.36 MHz crystal, 135  $\Omega$  line load, random 2B+D data,  $V_{DD} = 5 V \pm 0.25 V$ ,  $-40^{\circ}C$  to  $+85^{\circ}C$ , output capacitance = 50 pF.

**Table 24. Power Consumption**

Parameter	Test Conditions	Min	Typ	Max	Unit
Power Consumption	Operating, Random Data	—	275	350	mW
Power Consumption	Powerdown Mode	—	30	50	mW

**Table 25. Performance Ratings**

Parameter	Test Conditions	Min	Typ	Max	Unit
Warm Start Time	—	—	200	—	ms
Cold Start Time	—	—	3.5	—	s
Error Rate over 18 kft	26 AWG cable	—	—	$10^{-7}$	—

**Table 26. Crystal Characteristics: Fundamental Mode Crystal**

These are the characteristics of a crystal for meeting the  $\pm 100$  ppm requirements of T1.601 for NT operation.

Parameter	Symbol	Test Conditions	Specifications	Unit
Center Frequency	Fo	With 25.0 pF of loading	15.36011	MHz
Tolerance Including Calibration, Temperature Stability, and Aging	ToL	—	$\pm 60$	ppm
Drive Level	DL	Maximum	0.5	mW
Series Resistance	Rs	Maximum	20	$\Omega$
Shunt Capacitance	Co	—	$3.0 \pm 20\%$	pF
Motional Capacitance	Cm	—	$12 \pm 20\%$	fF

The parasitic capacitance of the PC board to which the T7264 crystal is mounted must be kept within the range  $0.6 \pm 0.4$  pF.

For LT operation or for NT applications that can tolerate a free-running frequency tolerance of up to  $\pm 150$  ppm, ToL and Cm may be relaxed as long as they satisfy the following:

$$| \text{ToL} + (3300 \text{ ppm}) \times C_m \text{ (in pF)} | \leq 150 \text{ ppm}$$

using the nominal value of Cm. All other parameters are unchanged except that the shunt capacitance, Co, should change in proportion with any change in Cm.

Possible sources for 15.36 MHz crystals for use with the T7264 include:

CTS Knights  
Tom Haney at 1-704-684-0242  
P/N 020-2807-0

MTRON\*  
William J. Winch  
(Winch Sales Associates)  
at 1-908-613-1515  
P/N 4044-001

Saronix  
Laura Derrickson at 1-800-227-8974  
(in CA, 1-800-422-3355  
P/N SRX5144(-N)  
For LT applications, a relaxed specification part is available where TOL =  $\pm 85$  ppm and Cm = 18 fF  $\pm 20\%$ .  
P/N SRX5152(-N [no vinyl coating])

\* MTRON is a registered trademark of MTRON Industries, Inc., a wholly owned subsidiary of Lynch Corporation. (Lynch is a registered trademark of Lynch Corporation.)

**Electrical Characteristics** (continued)**Table 27. Internal PLL Characteristics**

Parameter	Test Conditions	Min	Typ	Max	Unit
Total Pull Range	—	±250	—	—	ppm
Jitter Transfer Function	–3 dB point (LT)	—	0.45*	—	Hz
	–3 dB point (NT), 18 kft 26 AWG	—	5*	—	Hz
Jitter Peaking	at 0.15 Hz typical (LT)	—	0.4*	—	dB
	at 1.5 Hz typical (NT)	—	1.0*	—	dB

\* Set by digital PLL; therefore, variations track MTC (LT mode) or U-interface line rate (NT mode).

**Table 28. Digital dc Characteristics (Over Operating Ranges)**

Parameter	Symbol	Test Conditions	Min	Typ	Max	Unit
Input Leakage Current:						
Low	I <sub>IL</sub>	V <sub>IL</sub> = 0 (pin 1, 2)	–10	—	—	μA
High	I <sub>IH</sub>	V <sub>IH</sub> = V <sub>DD</sub> (pin 1, 2)	—	—	10	μA
Low	I <sub>ILpu</sub>	V <sub>IL</sub> = 0 (pins 7–11, 14–15, 24–26)	–52	—	–10	μA
High	I <sub>IHpu</sub>	V <sub>IH</sub> = V <sub>DD</sub> (pins 7–11, 14–15, 24–26)	—	—	10	μA
Input Voltage:						
Low	V <sub>IL</sub>	All Pins Except Pin 7, 10, 11, 24	—	—	0.8	V
High	V <sub>IH</sub>	All Pins Except Pin 7, 10, 11, 24	2.0	—	—	V
Low-to-High Threshold	V <sub>ILs</sub>	Pin 7	V <sub>DD</sub> – 0.5	—	—	V
High-to-Low Threshold	V <sub>IHs</sub>	Pin 7	—	—	0.5	V
Low	V <sub>ILc</sub>	Pins 10, 11, 24	—	—	0.2 V <sub>DD</sub>	V
High	V <sub>IHc</sub>	Pins 10, 11, 24	0.7 V <sub>DD</sub>	—	—	V
Output Leakage:						
Low	I <sub>OZL</sub>	V <sub>OL</sub> = 0; Pin 26 = 0	10	—	—	μA
High	I <sub>OZH</sub>	V <sub>OH</sub> = V <sub>DD</sub> ; Pin 26 = 0	—	—	–10	μA
Output Leakage:						
Low, TTL	V <sub>OL</sub>	I <sub>OL</sub> = 1.6 mA, Pins 3, 4, 5, 16	—	—	0.4	V
		I <sub>OL</sub> = 3.3 mA, Pin 43	—	—	0.4	V
		I <sub>OL</sub> = 6.5 mA, Pins 13, 23	—	—	0.4	V
High, TTL	V <sub>OH</sub>	I <sub>OH</sub> = 2.4 mA, Pins 3, 4, 5, 16	2.4	—	—	V
		I <sub>OH</sub> = 5.1 mA, Pin 43	2.4	—	—	V
		I <sub>OH</sub> = 10.4 mA, Pins 13, 23	2.4	—	—	V

**Loop-Range Performance Characteristics**

The T7264 transceiver is designed to allow systems to meet the loop-range requirements of ANSI Standard T1.601-1992 when the transceiver is used with the proper peripheral circuitry.

The line driver provides pulses that produce the 2.5 V template required of the T1.601 specification when connected to the proper transformer and interface circuitry.

### Timing Characteristics

Output Capacitance = 50 pF,  $T_A = -40\text{ }^\circ\text{C}$  to  $+85\text{ }^\circ\text{C}$ ,  $V_{DD} = 5\text{ V} \pm 5\%$ ,  $GND = 0\text{ V}$ , crystal frequency = 15.36 MHz.

Table 29. Clock Timing (See Figures 25, 26, and 28.)

Symbol	Parameter	Min	Typ	Max	Unit
F	8 kHz Duty Cycle	49.8	—	50.2	%
C	512 kHz Duty Cycle	46	—	54	%
RCLKEN	80 kHz Duty Cycle	48	—	52	%
CKOUT	Duty Cycle:				
	In 7.68 MHz Mode	45	—	55	%
	In 15.36 MHz Mode	40	—	60	%
	Pulse Width (high)				
	In 10.24 MHz Mode	23*	—	52*	%
tR1, tF1	Rise or Fall Time	—	30	—	ns
tCHF1, tFHCH	Clock (C) High to Frame Sync (F)	-15	—	15	ns
tRCHRCH	CKOUT Clock to RCLKEN Clock Enable	—	—	25	ns
tCOLFH	CKOUT Clock to Frame Sync (F)	—	—	50	ns
tDIVCL, tCLDIZ	Receive Data (DI) Setup & Hold Time	50	—	—	ns
tCHDOV	Clock (C) High to Data (DO) Valid	—	—	50	ns
tR2, tF2	CKOUT Clock Rise or Fall	—	15	—	ns
tCHOSV	Clock (C) High to Out of Sync $\overline{\text{OSYNC}}$ Valid	—	—	60	ns

\*Includes the effect of phase steps generated by the digital phase-locked loop.

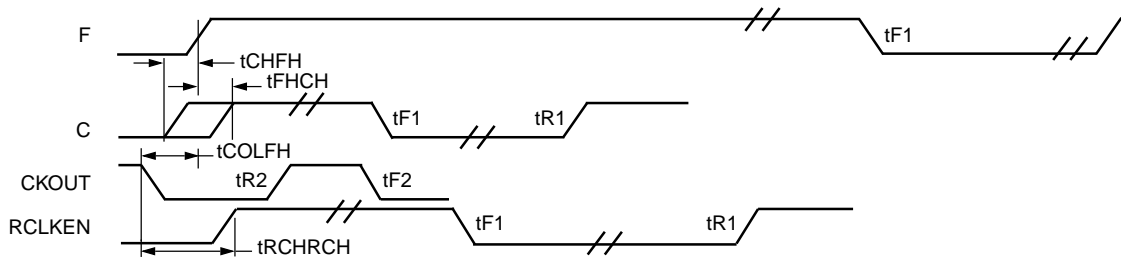

5-5184

Figure 25. Timing Diagram Referenced to F

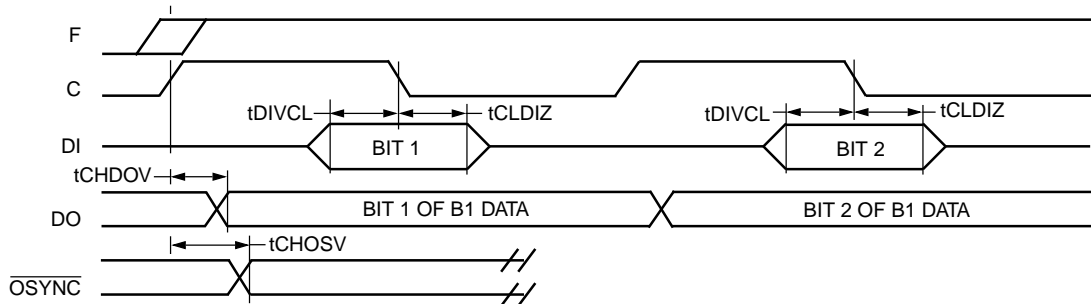

5-5185

Figure 26. Timing Diagram Referenced to C

**Timing Characteristics** (continued)

**Table 30. MTC Requirements and Characteristics\* (LT Mode)**

Parameter	Min	Typ	Max	Unit
MTC Clock Period	125 – 32 ppm	125	125 + 32 ppm	μs
MTC High/Low Time	8	—	—	MCLKs
MTC Rise/Fall Time	—	—	60	ns
MTC Jitter	—	—	0.259	UI <sup>†</sup>

\* To meet ANSI T1.601-1992, see note for Recommended Operating Conditions.

† One UI = 12.5 μs.

**Table 31. RESET Timing** (See Figures 27 and 28.)

Symbol	Parameter	Min	Max	Unit
tRSLFL, tFLRSH	RESET Setup and Hold Time	60	—	ns
tRSLRSH	RESET Low Time: From Idle Mode or Normal Operation From Power On	3 1.5	— —	K2 frames ms

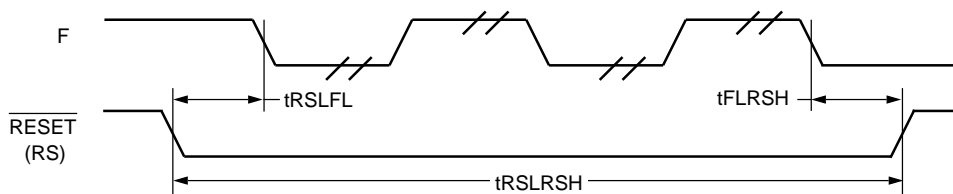

5-5186

**Figure 27. RESET Timing Diagram**

**Switching Test Input/Output Waveform**

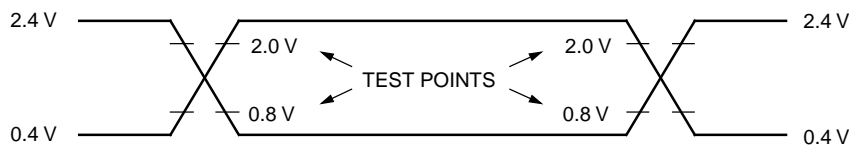

5-5187

**Figure 28. Switching Test Waveform**



## T7264 U-Interface 2B1Q Transceiver

### Appendix A. Questions and Answers

#### Introduction

The questions and answers are divided into three categories: U-interface, K2 interface, and miscellaneous.

For detailed application information, also refer to the application notes Implementation of an ANSI Standard ISDN NT1 Using the Lucent T7262A/63, T7252A, T7270, and an 8-Bit Microcontroller and Performance Factors in Line-Powered 2B1Q Applications.

#### U-Interface

**Q1:** Is the line interface for the T7264 the same as the T7262A/63?

**A1:** The interface is different in that the T7262A/63 uses a Lucent 2754G transformer (2.5:1 turns ratio), and the T7264 uses a Lucent 2754H transformer (1.5:1 turns ratio).

Other changes to the line interface include device-side resistors of  $16.9 \Omega \pm 1\%$  and line-side resistors of  $16.9 \Omega \pm 7\%$ . Part of the line-side resistance will likely be a PTC in those applications requiring power cross protection.

The T7264 device-side protection is unchanged (521A diodes), and the dc blocking capacitor is unchanged (Illinois Capacitor\*  $1.0 \mu\text{F} \pm 5\%$ ).

Line-side protection must be tailored to individual system needs.

**Q2:** Why is a higher transformer magnetizing inductance used (as compared to other vendors)?

**A2:** It has been determined that a higher inductance provides better linearity. Furthermore, it has been found that a higher inductance at the far end provides better receiver performance at the near end and better probability of start-up at long loop lengths.

**Q3:** Can the T7264 be used with a transformer that has a magnetizing inductance of 20 mH?

**A3:** The echo canceler and tail canceler are optimized for a transformer inductance of approximately 80 mH and will not work with a value this low.

**Q4:** Are the Lucent U-interface transformers available as surface-mount components?

**A4:** Not at this time.

**Q5:** Are there any future plans to make a smaller height 2-wire transformer?

**A5:** Due to the rigid design specifications for the transformer, vendors have found it difficult to make the transformer any smaller. We are continuing to work with transformer vendors to see if we can come up with a smaller solution.

**Q6:** The line interface components' specifications require  $16.9 \Omega$  resistors on the line side of the transformer. We would like to change this value for our application. Can the U-interface line-side circuit be redesigned to change the value of the line-side resistors?

**A6:** Yes. For example, the line-side resistances can be reflected back to the device side of the transformer so that, instead of having  $16.9 \Omega$  on each side of the transformer, there are no resistors on the line side of the transformer and  $24.4 \Omega$  resistors on the device side ( $16.9 + 16.9/N^2$ , where  $N$  is the turns ratio of the transformer). However, there may be some performance penalty in this case since the on-chip hybrid network is optimized for  $16.9 \Omega$  of resistance on the device side of the transformer.

\* Illinois Capacitor is a registered trademark of Illinois Capacitor Inc.



## Appendix A. Questions and Answers

(continued)

**Q7:** Why are the line-side resistors (16.9  $\Omega$ ) rated at 7% tolerance in Figure 4 of the data sheet?

**A7:** This tolerance was determined based on analysis of the output voltage tolerance of the T7262A/63 solution as compared to the T7264 solution, taking into account the tolerances of the transformer, resistors, etc. It is not a standard resistor tolerance, such as 5%, because as much flexibility as possible was desired. The 16.9  $\Omega$  resistor is often a combination of a resistor and a positive temperature coefficient (PTC) surge-protection resistor, and PTCs generally have wider tolerances.

Some 2B1Q manufacturers try to match the PTCs in such a way that their variations from the nominal value are in the same direction. However, it is important to use as tight a tolerance as possible for the following reasons:

- The 16.9  $\Omega$  resistor is also part of the termination impedance looking into Tip/Ring. ANSI specifies this impedance at 135  $\Omega$  nominal, and the impedance template over the specified frequencies is derived from the return loss requirement (T1.601, Sections 7.1, 7.2, and Figure 19). A tighter tolerance on the 16.9  $\Omega$  resistors allows more margin on the return loss template.
- If resistors are unmatched, longitudinal balance (described in T1.601, Section 7.3) may be affected. Designers can experimentally determine the maximum tolerance allowed in their system by varying the 16.9  $\Omega$  resistors slightly and observing the effect on the parameters mentioned above.

**Q8:** The dc blocking capacitor specified is 1  $\mu$ F. Can it be increased to at least 2  $\mu$ F?

**A8:** Yes. This value can be increased without any detrimental effect.

**Q9:** The application diagram in the data sheet shows the loopback relay on the line side of the transformer. Why is it not shown on the device side?

**A9:** The relay can be located on the device side between the 521A surge protector and the transformer, and the local loopback will function properly. It is shown on the line side because in many applications the relay is a DPDT type and is also used for metallic access to some line testing equipment (at an LT, for example).

**Q10:** If the relay is on the line side, what type should it be?

**A10:** Relay type is application-dependent. An example of a relay which would work in most cases is an Aromat\* DS Series 2 A relay.

**Q11:** Clarify the meaning of the note concerning the 3000 pF capacitors in the U-line interface figure (Figure 4).

**A11:** The capacitors are not absolutely required. The ANSI T1.601 specification contains no requirements on longitudinal noise immunity. Therefore, these capacitors are not required in order to meet the specification. However, there are guidelines in IEC 801-6 which suggest a noise immunity of up to 10 Vrms between 150 kHz and 250 MHz. At these levels, the 10 kHz tone detector in the T7264 may be desensitized such that tone detection is not guaranteed on long loops. The 3000 pF was selected to provide attenuation of this common-mode noise so that tone detector sensitivity is not adversely affected. Since the 3000 pF capacitor was selected based only on guidelines, it is not mandatory, but it is recommended in applications which may be susceptible to high levels of common-mode noise. The final decision depends on the specific application.

\* Aromat is a registered trademark of Aromat Corporation.

**Appendix A. Questions and Answers**

(continued)

**Q12:** Why must secondary protection, such as the 521A protection diode, be used?

**A12:** The purpose of the 521A is to protect against metallic surges below the breakdown level of the primary protector.

Such metallic surges will be coupled through the transformer and could cause device damage if the currents are high. The 521A does not provide absolute protection for the device, but rather works in conjunction with the built-in protection on the device leads.

The breakdown voltage level for secondary protection devices must be chosen to be above the normal working voltage of the signal and typically below the breakdown voltage level of the next stage of protection. The 521A has a minimum breakdown voltage level of 6.95 V and a maximum breakdown voltage of 8.0 V.

The chip pins which the 521A protects are pins 36 (HP), 31 (HN), 32 (LOP), and 35 (LON). The 16.9  $\Omega$  resistors will help to protect pins 32 and 35, but pins 31 and 36 will be directly exposed to the voltage across the 521A. The on-chip protection on these pins consists of output diodes and a pair of polysilicon resistors. These pins have been thoroughly tested to ensure that an 8 V level will not damage them; therefore, no third level of protection is needed between the 521A and the HP and HN pins.

The 521A has a maximum reverse surge voltage level of 10 V at 50 A. Sustained currents this large are not a concern in this application, since it is assumed that some form of primary protection is being used, such as the Teccor\* P2103AA SIDACTor\*. Thus, there should never be more than 8.0 V across the 521A, except for possibly an ESD or lightning hit. In these cases, the T7264 is able to withstand at least  $\pm 500$  V (human-body model) on its pins.

Another consideration is the capacitive loading that the protection device presents to the target device. This is generally required to be negligible at the operating frequency.

From a practical point of view, the device is chosen to meet not only voltage, current, and capacitance requirements, but also to meet price, availability, manufacturing, and second-sourcing requirements. The 521A device is a general-purpose device that meets system requirements for voltage, current, capacitance, price, etc., for some of Lucent's customers. Other devices which may be acceptable alternates are as follows: Motorola<sup>†</sup> SA6.0C (through-hole and surface-mount), Microsemi SMSJ6.0C-SMB (surface-mount), and SGS-Thomson<sup>‡</sup> SM6T6V8C (surface-mount).

**Q13:** Bellcore TR-TSY-000078, Section 3.2.4.1, prohibits using silver metallization, but the 521A protection diodes have silver-plated leads. Does this indicate an incompatibility problem?

**A13:** Bellcore TR-TSY-000078, Section 3.2.4.1 prohibits silver "... when electromigration is a problem." The 521A diodes are only used as secondary protection, and, therefore, almost never carry any current. Electromigration occurs only when there is a high current flow for an extended period of time. Since the diodes are never subjected to this condition, electromigration is not a problem, and the silver plating is acceptable.

**Q14:** Where can information be obtained on lightning and surge protection requirements for 2B1Q products?

**A14:** ANSI T1.601, Appendix B, provides a list of applicable specifications to which you may refer. Also, there are many manufacturers of overvoltage protection devices who are familiar with the specifications and would be willing to assist in surge protection design. The ITU-T K series recommendations are also a good source of information on protection, especially Recommendation K.11, "Principles of Protection Against Overvoltages and Overcurrents," which presents an overview of protection principles.

\* Teccor and SIDACTor are trademarks of Teccor, Inc.

† Motorola is a registered trademark of Motorola, Inc.

‡ SGS-Thomson is a registered trademark of SGS-Thomson Microelectronics, Inc.

## Appendix A. Questions and Answers

(continued)

**Q15:** ITU-T specification K.21 describes a lightning surge test for NT1s (see Figure 1/K.21 and Table 1/K.21, Test #1) in which both Tip and Ring are connected to the source and a 1.5 kV voltage surge is applied between this point and the GND of the NT1. What are the protection considerations for this test? Are the HP and HN pins susceptible to damage?

**A15:** The critical component in this test is the transformer since its breakdown voltage must be greater than 1.5 kV. Assuming this is the case, the only voltage that will make it through to the secondary side of the transformer will be primarily due to the interwinding capacitance of the transformer coils.

This capacitance will look like an impedance to the common-mode surge and will therefore limit current on the device side of the transformer. The device-side voltage will be clamped by the 521A device. The maximum breakdown voltage of the 521A is 8 V. The 16.9  $\Omega$  resistors will help protect the LOP and LON pins on the T7264 from this voltage. However, this voltage will be seen directly on pins 36 and 31 (HP and HN) on the T7264. The on-chip protection on these pins consists of output diodes and a pair of polysilicon resistors. These pins have been thoroughly tested to ensure that an 8 V level will not damage them; therefore, no third level of protection is needed between the 521A and the HP and HN pins.

**Q16:** How is it possible to guarantee the  $\pm 0.35$  dB power spectrum tolerance on the U-interface?

**A16:** By trimming to  $\pm 0.1$  dB; the rest of the variation is for power supply, temperature, and aging.

**Q17:** Is the  $\pm 100$  ppm free-run frequency (NT mode) recommendation met in the T7264?

**A17:** In the free-run mode, the output frequency is primarily dependent upon the crystal, not the silicon design. For low-cost crystals, initial tolerance, temperature, and aging effects may account for two-thirds of this budget, and just a couple of pF of variation in load capacitance will use up the rest. Thus, the  $\pm 100$  ppm goal can be met if the crystal parameters are well controlled. See the Crystal Characteristics information in the data sheet (Table 26).

**Q18:** It has been noted in some other designs that the crystal has a capacitor from each pin to ground. Changing these capacitances allows the frequency to be adjusted to compensate for board parasitics. Can this be done with the T7264 crystal? Also, can we use a crystal from our own manufacturer?

**A18:** The crystal for the T7264 is tuned to a particular load capacitance that does not include external capacitors. The advantage to this is that no external components are required. The disadvantage is that board parasitics must be very small. The data sheet notes that the board parasitics must be within the range of  $0.6 \text{ pF} \pm 0.4 \text{ pF}$ . Lucent does not require that a particular crystal be used, but we strongly recommend adhering to the crystal parameters specified in the data sheet. A crystal which deviates from these parameters can work under most conditions, but we cannot guarantee that it will start up and/or meet the  $\pm 100$  ppm requirement under all operating conditions.

**Q19:** Is there a test pin available for generating a +3/-3 sequence so that pulse templates can be measured easily?

**A19:** There is no such pin. But a sequence of four +3s, followed by four -3s (and so on) is the 10 kHz wakeup tone (TN, TL in ANSI T1.601, Figure 17) that each transceiver outputs when initiating a start-up. This tone is produced when the K2 bit, istp in the dc octet, is asserted. At the NT, this tone lasts for 9 ms (90 pulses), and at the LT, it lasts for 3 ms (30 pulses). This should be long enough to capture the data on a digitizer or storage scope for analysis.

**Q20:** What are the average cold start and warm start times?

**A20:** Lab measurements have shown the average cold start time to be about 3.3 s—4.2 s over all loop lengths, and the average warm start time to be around 125 ms—190 ms over all loop lengths.

**Q21:** What is the U-interface's response time to an incoming wakeup tone from the LT?

**A21:** Response time is about 1 ms.

**Q22:** What is the minimum time for a U-interface reframe after a momentary (<480 ms) loss of synchronization?

**A22:** Five superframes (60 ms).

T7264 U-Interface 2B1Q Transceiver

Appendix A. Questions and Answers

(continued)

**Q23:** Can the range of the T7264 on the U-interface be specified in terms of loss? What is the range for over straight 24 AWG wire?

**A23:** ANSI Standard T1.601, Section 5.1, states that transceivers meeting the U-interface standard are intended to operate over cables up to the limits of 18 kft (5.5 km) 1300 Ω resistance design. Resistance design rules specify that a loop (of single- or mixed-gauge cable; e.g., 22 AWG, 24 AWG, and 26 AWG) should have a maximum dc resistance of 1300 Ω, a maximum working length of 18 kft, and a maximum total bridged tap length of 6 kft.

The standard states that, in terms of loss, this is equivalent to a maximum insertion loss of 42 dB @ 40 kHz. Lucent has found that, for assessing the condition of actual loops in the field in a 2B1Q system, specifying insertion loss as 33.4 dB @ 20 kHz more closely models ANSI circuit operation. This is equivalent to a straight 26 AWG cable with 1300 Ω dc resistance (~15.6 kft).

The above goals are for actual loops in the outside loop plant. These loops may be subjected to noise and jitter. In addition, as mentioned above, there may be bridge taps at various points on the loop. The T1.601 standard defines 15 loops, plus the null, or 0 length loop, which are intended to represent a generic cross section of the actual loop plant.

A 2B1Q system must perform over all these loops in the presence of impairments with an error rate of  $<1e-7$ . Loop #1 (18 kft, where 16.5 kft is 26 AWG cable and 1.5 kft is 24 AWG cable) is the longest, and so has the most loss (37.6 dB @ 20 kHz and 47.5 dB @ 40 kHz). Note that this is more loss than discussed in the preceding paragraph. The difference is based on test requirements vs. field deployment. The test requirements are somewhat more stringent than the field goal in order to provide some margin against severe impairments, complex bridged taps, etc.

If a transceiver can operate over Loop #1 error-free, it should have adequate range to meet all the other loops specified in T1.601. Loop #1 has no bridged taps, so passing Loop #1 does not guarantee that a transceiver will successfully start up on every loop. Also, due to the complex nature of 2B1Q transceiver start-up algorithms,

there may be shorter loops which could cause start-up problems if the transceiver algorithm is not robust. The T7264 has been tested on all of the ANSI loops per the T1.601 standard and passes them all successfully. Two loops commonly used in the lab to evaluate the performance of the T7264 silicon are as follows:

Loop Configuration	Bridge Taps (BT)	Loss @ 20 kHz (dB)	Loss @ 40 kHz (dB)
18 kft 26 AWG	None	38.7	49.5
15 kft 26 AWG	2 at near end, each 3 kft, 22 AWG	37.1	46.5

The T7264 is able to start up and operate error-free on both of these loops. Neither of these loops is specified in the ANSI standard, but both are useful for evaluation purposes. The first loop is used because it is simple to construct and easy to emulate using a lumped parameter cable model, and it is very similar to ANSI Loop #1, but slightly worse. Thus, if a transceiver can start up on this loop and operate error-free, its range will be adequate to meet the longest ANSI loop.

The second loop is used because, due to its difficult bridge tap structure and its length, it stresses the transceiver start-up algorithms more than any of the ANSI-defined loops. Thus, if a transceiver can start up on this loop, it should be able to meet any of the ANSI-defined loops which have bridge taps. Also, on a straight 26 AWG loop, the T7264 can successfully start up at lengths up to 21 kft. This fact, combined with reliable start-up on the 15 kft 2BT loop above, illustrates that the T7264 provides ample start-up sensitivity, loop range, and robustness on all ANSI loops.

Another parameter of interest is pulse height loss (PHL). PHL can be defined as the loss in dB of the peak of a 2B1Q pulse relative to a 0 length loop. For an 18 kft 26 AWG loop, the PHL is about 36 dB, which is 2 dB worse than on ANSI Loop #1. A signal-to-noise ratio (SNR) measurement can be performed on the received signal after all the signal processing is complete (i.e., at the input to the slicer in the decision feedback equalizer). This is a measure of the ratio of the recovered 2B1Q pulse height vs. the noise remaining on the signal. The SNR must be greater than 22 dB in order to operate with a bit error rate of  $<1e-7$ .

## Appendix A. Questions and Answers

(continued)

**A23:** (continued)

With no impairments, the T7264 SNR is typically 32 dB on the 18 kft 26 AWG loop. When all ANSI-specified impairments are added, the SNR is about 22.7 dB, still leaving adequate margin to guarantee error-free operation over all ANSI loops.

Finally, to estimate range over straight 24 AWG cable, the 18 kft loop loss can be used as a limit (since the T7264 can operate successfully with that amount of loss), and the following calculations can be made:

Loss of 18 kft 26 AWG loop @ 20 kHz	38.7 dB
Loss per kft of 24 AWG cable @ 20 kHz	1.6 dB

$$\frac{38.7 \text{ dB}}{1.6 \text{ dB/kft}} = 24 \text{ kft}$$

Therefore, the operating range over 24 AWG cable is expected to be about 24 kft.

**Q24:** What cable simulator is used for evaluating the T7264?

**A24:** The original version of the transceiver was tested using real cable for ANSI loop performance measurements. However, currently, the Lucent Technologies Microelectronics Group laboratory uses the TAS2200A\* Cable Emulator for evaluation purposes.

**Q25:** The data sheet states that the T7264 meets the ANSI T1.601-1992 standard. Is there detailed evaluation data available on loops 1 and 4?

**A25:** The results shown in the following table for some typical devices have been obtained in laboratory testing. Loops 1 and 4 are the most difficult cases.

ANSI Loop #	Configuration	1992 ANSI XTALK Margin (dB)
1	LT	1.9
4	LT	7.6

**Q26:** What does the energy spectrum of a 2B1Q signal look like?

**A26:** Figure A1 (curve P1) in the ANSI T1.601 standard gives a good idea of what this spectrum looks like.

**Q27:** Does the return loss measurement described in ANSI T1.601, Section 7, require that the T7264 terminate a metallic cable with 135 Ω during powerdown?

**A27:** No. ANSI and ETSI specifications do not require this. They require that the device be placed in an active mode with the transmitter producing 0 V (same as quiet mode) while performing the return loss measurements. The T7264 is placed in this mode by pulling the RESET pin low.

**Q28:** How is the T7264 set to quiet mode?

**A28:** The device is placed in the quiet mode by pulling the RESET pin low. In this mode, the transmitter is on, but is producing 0 V.

**Q29:** Please clarify the meaning of ANSI Standard T1.601, Section 7.4.2, Jitter Requirement #3.

**A29:** The intent of this requirement is to ensure that after a deactivation and subsequent activation attempt (warm start), the phase of the receive and transmit signals at the NT will be within the specified limits relative to what they were prior to deactivation. This is needed so that the LT, upon a warm-start attempt, can make an accurate assumption about the phase of the incoming NT signal with respect to its transmit signal. Note that the T7264 meets this requirement by design because the NT phase offset from transmit to receive is always fixed.

**Q30:** How can proprietary messages be passed across the U-interface?

**A30:** The embedded operations channel (eoc) provides one way of doing this. ANSI defines 64 8-bit messages which can be used for non-standard applications. They range in value from binary 00010000 to 01000000.

There is also a provision for sending bulk data over the eoc. Setting the data/message indicator bit to 0 indicates the current 8-bit eoc word contains data that is to be passed transparently without being acted on. Note that there is no response time requirement placed on the NT in this case (i.e., the NT does not have to echo the message back to the LT). Also note that as of 1993 this is only an ANSI provision and is not an ANSI requirement. The T7264 does support this provision.

\* TAS2200A is a trademark of Telecom Analysis Systems Incorporated.

## T7264 U-Interface 2B1Q Transceiver

## Appendix A. Questions and Answers

(continued)

## K2 Interface

**Q31:** How are powerdown and warm start performed in the T7264?

**A31:** The powerdown/warmstart sequence is as follows:

- At the LT, the series of events begins with the assertion of  $I_{dea} = 1$ . This causes the device to begin the automatic deactivation sequence. As long as the device control bits ( $istp$ ,  $l_{pbk}$ , and  $afrst$ ) and the  $\overline{RESET}$  and  $\overline{LOSS}$  pins remain inactive during this time, the LT device concludes deactivation by entering the powerdown state. From this condition, the loop can be reactivated by using a warm start.
- At the NT, the device receives at least three consecutive  $I_{dea} = 0$  bits from the LT during deactivation. These bits must be read from the K2 interface and interpreted to indicate that a deactivation is occurring. Once this condition is detected, the external controller must set  $I_{dea} = 1$  at the NT, causing the device to freeze its signal processor coefficients and power down when a loss of signal from the LT is detected. During this time, the device control bits ( $istp$ ,  $l_{pbk}$ ,  $afrst$ , etc.) and the  $\overline{RESET}$  and  $\overline{LOSS}$  pins must remain inactive at the NT. From this condition, the loop can be reactivated with a warm start.

**Q32:** Does the device automatically reset and attempt a cold start if out of frame (oof) occurs after a warm start?

**A32:** When an oof condition occurs, the device enters a reframing algorithm and attempts to regain synchronization. During this time, the device is still active. If, after 480 ms, the device has not regained synchronization, it goes into the deactive state, from which the next start-up attempt will result in a cold start. This conforms to the state tables shown in Appendix C of ANSI T1.601.

**Q33:** What is the purpose of the  $r_{sksi}$  bit in the device control (DC) octet?

**A33:** Its primary use is to detect a "stuck at one" condition on the K2 interface. It is reflected back onto the K2 interface as  $r_{sksi}$  in the DS octet. Setting

$r_{sksi}$  to 0 will guarantee that at least one bit ( $r_{sksi}$ ) will be zero on the received K2 interface.

**Q34:** What should the state of the other bits in the DC octet be during a local U-loopback?

**A34:** To perform a loopback, the following sequence of bits are set in the DC octet, where 1 resets the device and puts it into a known state, 2 asserts the loopback, and 3 resets the chip again and removes the loopback. The other DC bits should be kept in their inactive state:

1.  $afrst = 1$ ,  $l_{pbk} = x$ ,  $istp = 1$ ,  $xpcy = x$  [loopback = inactive]
2.  $afrst = 0$ ,  $l_{pbk} = 0$ ,  $istp = 1$ ,  $xpcy = x$  [loopback = active]
3.  $afrst = 1$ ,  $l_{pbk} = 1$ ,  $istp = 1$ ,  $xpcy = x$  [loopback = inactive]

**Q35:** What is the state of the DO bits when OSYNC goes low momentarily after the link is up?

**A35:** The 2B+D data and U-overhead bits are passed transparently from the U-interface to the K2 interface. Since this U-information is likely to be invalid during this time, the system should recognize this and disregard the data and overhead bits during this time. Note that this situation is different than when OSYNC is low prior to a start-up. In the latter case, the 2B+D and overhead bits are internally overwritten by the transceiver to default values until synchronization is achieved (see the data sheet for these values). In either case, the DS bits are always valid.

**Q36:** ANSI requires 0.75 ms to process the eoc message at the NT before echoing it. The T7264 data sheet, however, states that the time from when an incoming message becomes available and the next message goes out is 1.75 ms. How can the T7264 meet the standard?

**A36:** The 0.75 ms in the ANSI requirement refers to the delay between the start of the received U frame and the start of the transmitted U frame. In the eoc bit locations, there are SW/ISW plus 12 2B+D blocks of data between the last bit of one eoc message and the first bit of the next one. This provides an additional 1.46 ms of processing time or a total of 2.21 ms. Of course, some of this time is consumed by the T7264 in moving data between the U and K2 interfaces. After these delays are taken into consideration, 1.75 ms remain to process data.

## Appendix A. Questions and Answers

(continued)

**Q37:** What are the requirements on the transmission and reception of eoc data on the K2 interface?

**A37:** This is described on page 24, Figure 18, of this data sheet. To summarize, the received eoc data changes at K2 frames 47 and 95 (where frame 0 is marked by the rising edge of RSF). The most recent eoc data is continuously available on the K2 bus in the intervals between frames 47 and 95. The eoc data to be transmitted must be present on the K2 interface at outgoing K2 frames 11 and 59 (where frame 0 is marked by the rising edge of TSF). Since it is sampled only at those times, it does not matter what is present in those bit positions in the intervals between frames K11 and K59.

For an LT, normally it will not matter in which K2 frames the eoc data is written and read, as long as the read/writes are done at 6 ms intervals (i.e., every 48 K2 frames). This is because there is no critical timing involved between the reception of an eoc message and its response, as there is at an NT.

For an NT, ANSI T1.601, Section 8.3.2, specifies that the eoc response must occur in the next available outgoing eoc frame. This means that the system has 13 K2 frames between the reception of a new eoc message at frame K95 (relative to RSF) and the transmission of the response to that message. Thus, the eoc timing at the NT should be referenced to RSF. Because of well-defined timing between RSF and TSF at the NT, there is no reason to use TSF for eoc timing.

**Q38:** The data sheet states that  $adea = 0$  and  $Idea = 1$  should not be used at the same time; why not?

**A38:** This mode is not recommended because it could result in a system-level problem. Consider a typical deactivation sequence for a network having a remote NT1 (i.e., an LT-to-NT connection with at least one intermediate element, as shown in ANSI T1.601, Figure E1). The following table shows the events at the NT and LT when the LT initiates a deactivation. The LT uses  $adea$  in the

case of an intermediate element to propagate the deactivation bit downstream without shutting itself down (as it would do if  $Idea$  were set instead):

LT State	LT K2 Data In	NT K2 Data Out	NT Action
Normal Operation	$adea = 1$ $Idea = 0$	$dea = 1$	—
Downstream Deactivate	$adea = 0$ $Idea = 0$	$dea = 0$	Set $Idea = 1$ upon third consecutive $dea = 0$ *
After an appropriate amount of time to allow the message to propagate and the NT to react.			
LT Deactivates	$Idea = 1$ † $adea = 1$	x	Detects loss of signal and deactivates

\* This stores the coefficients and prepares the transceiver for deactivation. Deactivation will occur on loss of signal from the intermediate element.

† Stores the coefficients and deactivates the LT transmitter (stops transmitting).

Notice that  $adea = 0$  and  $Idea = 1$  are permitted at the last step. This is because the NT has already stored its coefficients; however, if  $Idea = 1$  were set earlier (for example, in step 2), the LT might deactivate before the downstream elements had stored their coefficients, and a clean deactivation would not occur. Therefore, to help avoid turning off the LT before all the downstream elements store their coefficients, this state was defined as invalid.

Also, note that  $Idea = 1$  will cause a chip set in the LT mode to store coefficients and deactivate, but it only causes a chip set in the NT mode to store coefficients. Deactivation at the NT only occurs upon loss of the U-interface signal.

**Note:** The preceding deactivation procedure is only an illustration. In a nonrepeater environment, step 2 could be  $adea = Idea = 1$ , which would cause the LT to automatically save its coefficients and, within three or four K2 frames, deactivate. This case assumes that the NT has properly detected  $dea = 0$  and then stored its coefficients within those three or four frames.

## Appendix A. Questions and Answers

(continued)

**Q39:** What is the relationship between *istp* and *Idea*?

**A39:** The *istp* bit should be set to 1 before or at the same time as *Idea* is set to 1. Once the chip set is deactivated, setting *istp* to 0 for at least three K2 frames will initiate start-up. However, it is necessary for *Idea* to be 0 before time T7 (see ANSI Table 5, Figure 16) for the start-up process to be successfully completed.

**Q40:** When should *nebes* and *febes* be counted?

**A40:** During activation, *nebes* and *febes* will occur at each end of the link between the time framing is initially achieved and the time the link is fully operational at each end. These *nebe/febe* occurrences are normal and are of no interest. Therefore, *nebe/febe* counters should be reset to zero after the link is fully operational. This is most easily achieved by delaying about 500 ms after getting *oof* = 1 and then resetting the *nebe/febe* counters.

**Q41:** How is the D+ channel for 3-DS0 TDM applications generated (Bellcore TR-TSY-000397)?

**A41:** Since the *crc* bits are not passed to the K2 interface, the D+ channel cannot be formed directly; those bits must be generated externally. Also, a recent standard ballot addressed this issue by noting that, in general, the form of the D+ channel is application-dependent, so a broad standard is not being developed.

**Q42:** How does RSF behave during a reframe?

**A42:** RSF behavior is transparent to the *oof* (out-of-frame) condition. Whenever the chip thinks it has found an ISW, it forces RSF high. RSF stays high for 12 K2 frames, at which point it goes low until the occurrence of the next ISW.

**Q43:** Does the K2 F clock do anything strange when a  $\overline{\text{RESET}}$  is asserted? This clock is being used to initialize an elastic store, and it seems to be producing some strange glitches.

**A43:** There are two ways to reset the chip:

1. Assert the  $\overline{\text{RESET}}$  pin low.
2. Assert the K2 *afrst* bit (DC octet) high.

The difference between these two resets is that #1 resets the entire chip, including the on-chip PLL, while #2 resets everything except the PLL. Therefore, for both resets, the counter which controls the frequency gets loaded to its initial value, but the counter which controls the phase only gets reset when the  $\overline{\text{RESET}}$  pin is asserted.

In the case described, this means that with either reset #1 or #2, the frequency counter controlling F will be reinitialized, which could cause a strange duty cycle on F for one clock period. But once this initialization occurs, the F clock immediately starts behaving normally, even if the  $\overline{\text{RESET}}$  control remains active (also, in the case of reset #1, the PLL starts to acquire). From a system standpoint, you can always count on F behaving predictably when  $\overline{\text{RESET}}$  is released because reset #1 or #2 must be asserted for at least 3 K2 frames, and the F clock duty cycle will stabilize after one K2 frame. So any logic for an elastic store which uses F should initialize upon exit from the reset state. However, be sure to consider the effect the shift in F may have on other parts of the system.

**Q44:** What is the phase relationship between MTC and F at the LT?

**A44:** F is phase-locked to MTC by a second-order PLL that has a -3 dB frequency of approximately 0.5 Hz and has about 0.4 dB of peaking.



## Appendix A. Questions and Answers

(continued)

### Miscellaneous

**Q45:** Does the T7264 have a second source?

**A45:** It is manufactured at multiple Lucent ME locations, but no second source outside Lucent is currently available.

**Q46:** Are digital I/Os TTL or CMOS compatible?

**A46:** Both. All I/Os are CMOS. They are specified at TTL because the current requirement makes this more difficult to meet. At higher output voltages, the current will be less, perhaps 100 mA at 3.5 V.

**Q47:** What is the current sinking capability of OSYNC?

**A47:** The OSYNC lead supports a standard TTL load and will sink (or source) 1.6 mA.

**Q48:** What are the tolerances of the various discrete components around the chip set?

**A48:** Discrete components and their tolerances are as follows:

Line-Side Resistors	16.9 $\Omega$ $\pm$ 7%
dc Blocking Capacitor	1.0 $\mu$ F $\pm$ 5%
Device-Side Resistors	16.9 $\Omega$ $\pm$ 1%
Bypass Capacitors	0.1 $\mu$ F $\pm$ 10%
Bypass Capacitors	1.0 $\mu$ F $\pm$ 10%

**Q49:** If a switching power regulator is used in the system, is there a frequency to which it should be set?

**A49:** A switching frequency of 80 kHz or higher multiples, synchronous to the 2B1Q band clock, would be optimal. An 80 kHz clock is available at pin 43 that is synchronous with the 2B1Q signals.

**Q50:** Please explain how to use the  $\overline{\text{FFC}}$  pin in detail and its purpose.

**A50:** The  $\overline{\text{FFC}}$  pin can be used in applications where the MTC clock is switched from one source to another and may have glitches during the switch. One example of this is in DLC applications when the system switches to a protection clock board, and a new MTC clock is used. Before the protection switch,  $\overline{\text{FFC}}$  should be brought low to freeze the internal states of the timing recovery circuitry. After the new clock has stabilized,  $\overline{\text{FFC}}$  can be

brought high again and the T7264 circuitry will lock to the new clock without dropping the U-interface. Without the  $\overline{\text{FFC}}$  function, the U-interface might be dropped while the new clock is being applied.

**Q51:** What is the meaning of free-running and phase-locked in Table 3 of this data sheet?

**A51:** In Table 3, CKOUT is defined to be either 3-stated, 15.36 MHz free-running, 7.68 MHz free-running, or 10.24 MHz phase-locked. Free-running means that the CKOUT clock is directly derived from the 15.36 MHz crystal oscillator clock that is not synchronous with the U-interface line rate. Phase-locked means that the 10.24 MHz CKOUT clock is synchronous with the U-interface line rate. This clock does not have 50% duty cycle, and will experience occasional duty-cycle adjustments (i.e., phase steps) to keep it synchronous with the U-interface. (See the note at the bottom of Table 3 in the data sheet.)

**Q52:** What are the filter characteristics of the PLL at the NT?

**A52:** The -3 dB frequency is approximately 5 Hz; peaking is about 1.2 dB.

**Q53:** Is it possible to get a T7264-based LT to operate properly with a NT without supplying an MTC clock?

**A53:** Yes. Tying MTC to +5 V will yield a  $\pm$ 100 ppm MTC, which a Lucent NT will be able to lock to in most cases. This configuration should be used for laboratory purposes only. For all serious performance testing, a  $\pm$ 32 ppm (or better) MTC should be used.

**Q54:** If there are several NT-mode T7264s on a board, can only one crystal be used to run them?

**A54:** Yes. The following is an explanation of how this is accomplished (refer to Table 3 on page 6 of this data sheet). First, connect a crystal in the normal fashion to one T7264; the VDDO, MCLK, and CKSEL pins should be set per the first entry in Table 3 (+5/0/0). Now set the VDDO, MCLK, and CKSEL pins on all the other T7264s as per the last entry in Table 3 (0/15.36/1), and use the 15.36 MHz signal coming from CKOUT (pin 23) of the first T7264 to provide the 15.36 MHz input to MCLK (pin 24) on the others.

T7264 U-Interface 2B1Q Transceiver

Appendix A. Questions and Answers

(continued)

**Q55:** Will the T7264 run in NT mode with the K2 clock slaved to an external backplane?

**A55:** The T7264 does not support this mode. For those applications where this is an issue, systems designers have generally provided some elastic store on the K2-to-backplane ASIC. The elastic store must be sized according to the amount of jitter which can be introduced into a system and the amount of jitter gain in the system APLLs.

For example, assume that the backplane clock is derived from a recovered T1 clock. The worst-case jitter for a T1 line is 0.259 UI at frequencies of 0.001 Hz—10 Hz. Considering that an LT-mode T7264 APLL has jitter peaking of 0.4 dB at 0.15 Hz, the 0.259 UI of jitter could be amplified to 0.271 UI. Since 0.271 UI of 80 kHz is 3.39  $\mu$ s, this is how much elastic store is required.

Note that this is a simplified example: there may be other APLLs in the system (for example, the T1-to-backplane clock APLL), and their peaking must be factored in also. In addition, it is desirable to design in some margin.

**Q56:** Is there a recommended method for powering the T7264? For example, is it desirable to separate the power supplies, etc.?

**A56:** The T7264 is not extremely sensitive to power supply schemes. Following standard practices of decoupling power supplies close to the chip and, if power and ground planes are not used, keeping power traces away from high-frequency signals, etc., should yield acceptable results. Separating the T7264 analog power supplies from the digital power supplies near the chip can yield a small improvement, and the same holds true for using power and ground planes vs. discrete traces.

**Note:** If analog and digital power supplies are separated, the XTAL power supply (VDDO) should be tied to the digital supplies (VDDD).

**Q57:** What is the effect of ramping down the power supply voltage on the device? When will it provide a valid reset? This condition can occur when a line-powered NT1's line cord is repeatedly plugged in and removed and plugged in again before the power supply has had enough time to fully ramp up.

**A57:** The device's reset is more dependent on the  $\overline{\text{RESET}}$  pin than the power supply to the device. As long as the proper input conditions on the  $\overline{\text{RESET}}$  pin (see Table 32) are met, the device will have a valid reset. Note that this input is a Schmitt-trigger input.

**Q58:** Does the output jitter of the 9 kHz F clock on an NT-mode T7264 meet the 5% peak-to-peak jitter requirement described in ITU-T I.430, Section 8.3, assuming the S/T transceiver is the T7252A?

**A58:** Yes, the 5% requirement applies to high-frequency jitter (>50 Hz) at the NT. The T7264 produces approximately 100 ns of high-frequency jitter in the NT mode on F, and the T7252A can accept up to 160 ns of high-frequency jitter on its input clock and still meet the I.430 requirement.

**Q59:** What should be known before having a T7264-based product conformance tested at Bellcore?

**A59:** A copy of the Bellcore Test Bed Interface Specification should be obtained from Bellcore to get the latest requirements.

The Bellcore specification, when last reviewed by Lucent, required that a unit under test provide access to the following signals or state indicators. (The T7264 pin name in upper case, or K2 bit name, lower case, which corresponds to the Bellcore-required signal, is enclosed in braces.)

**Transceiver Status Signals:**

Fully operational state indicator	{oof or OSYNC}
Full reset state indicator	{xact}
Loss-of-frame alignment (opt)	{oof or OSYNC}
RX crc check indicator (opt)	{nebe}

**Transceiver Control Signals:**

Transceiver full reset	{ $\overline{\text{RESET}}$ }
Transceiver activation	{istp}
LT transceiver deactivation	{Idea}
Transmit M1—M4 bit control	{K2 access}
Transmit 2B+D payload gating	{received act}
Continuous scrambled output	{ILOSS at NT}
test mode	{lpbk at LT}

**Intertransceiver Signals (LT only):**

Superframe timing	{conditioned tsf}
2.56 MHz clock	{CKOUT/4}

**Note:** T7264 must be optioned for a 10.24 MHz CKOUT.

**2B+D Test Access**

18-bit bursted clock and corresponding 2B+D serial data stream must be accessible in both transmit and receive directions.

## Appendix A. Questions and Answers

(continued)

**Q60:** In the idle mode, when `afrst` or `RESET` is active, the current increases from 6 mA (powerdown mode) to 40 mA—50 mA (normal mode). Is this proper behavior for the T7264? Also, is this a correct interpretation of the data sheet description of idle mode (page 10, third paragraph)?

**A60:** This behavior is proper for the T7264. The reason more current is needed in the reset state (i.e., `RESET` pin or `afrst` bit active) is that much of the analog circuitry (line driver, band gap voltage references, A/D, and D/A) is powered down during the idle state, but is active during the reset state. Notice that idle and reset are two different states: reset state overrides idle when the `RESET` pin or `afrst` is active. The reset state is normally a transient state which only lasts a short time, unless the reset function is being constantly asserted. This means that `RESET` should not be used indiscriminately as part of a general start-up procedure. The meaning of the third paragraph on page 10 in the data sheet is that at the end of a `RESET` condition, the transceiver will change to the idle state (only momentarily if a start-up request is being made via the `istp` bit or a far-end wakeup tone). In this way, the data sheet is consistent with these results.

**Q61:** Can you provide detailed information on the active power consumption of the T7264?

**A61:** When discussing active power measurement figures, it is important to note that the conditions under which power measurements are made are not always completely stated by 2B1Q integrated circuit vendors. For example, loop length is not typically mentioned in regard to power dissipation, yet power dissipation on a short loop is noticeably greater than on a long loop. There are two reasons for the increased power dissipation at shorter loop lengths:

1. The overall loop impedance is smaller, requiring a higher current to drive the loop.
2. The far-end transceiver is closer, requiring the near-end transceiver to sink more far-end current in order to maintain virtual ground at its transmitter outputs.

The lab measurements in the following table provide examples of how power dissipation varies with loop length for a specific T7264 with its 15.36 MHz CKOUT output enabled and driving 40 pF (see the next table below for information on CKOUT). Note that power dissipation with a zero length loop (the worst-case loop) is about 35 mW higher than a loop of >3 kft length. Thus, loop length needs to be considered when determining worst-case power numbers.

Loop Configuration	Power (mW)
18 kft/26 AWG	273
6 kft/26 AWG	273
3 kft/26 AWG	277
2 kft/26 AWG	280
1 kft/26 AWG	288
0.5 kft/26 AWG	296
0 kft	308
135 Ω load, ILOSS or Ipbk active, no far-end transceiver*	281.5

\* This is the configuration used in Method B discussed on the next page.

Also, in the case of the T7264, the use of the output clock CKOUT (pin 23) must be considered since its influence on power dissipation is significant. Some applications may make use of this clock, while others may leave it 3-stated. The power dissipation of CKOUT is as follows:

CKOUT Frequency (MHz)	Power Due to CKOUT 40 pF Load (mW)	Power Due to CKOUT No Load (mW)
15.36	21.3	11.0
10.24	17.7	9.1
7.68	12.6	6.6

The methods used to evaluate typical and worst-case power consumption are based on Lucent's commitment to provide its customers with accurate and reliable data. Measurements are performed as part of the factory test procedure using automated test equipment. Bench top tests are performed in actual ISDN systems to correlate the automated test data with a typical implementation. A conservative margin is then added to the test results for publication in the data sheets.

**Appendix A. Questions and Answers**

(continued)

**A61:** (continued)

The following tables provide power consumption data in several formats to allow customers to compare transceiver solutions.

The three test condition categories reflected in the tables have been designated Method A, which reflects T7264 data sheet measurements; Method B, which reflects data obtained with a method used by other vendors; and Method C, which details revised T7264 measurements.

**Method A**

Test Condition	Value
Loop Configuration	0 kft*
Temperature	25 °C†
Power Supply Voltage	5 V
CKOUT	15.36 MHz
Max. Power Consumption	350 mW

\* This is the worst-case loop.

† 3 mW should be added for 85 °C.

The test conditions reflected in Method B represent a configuration used by other silicon vendors which eliminates the far-end transceiver from the network. This configuration should not be used to determine a system's total power requirements, but it can be used for comparison purposes among silicon solutions.

**Method B**

Test Condition	Value
Loop Configuration	135 Ω load only*
Temperature	25 °C†
Power Supply Voltage	5 V
CKOUT	3-stated‡
Max. Power Consumption	275 mW

\* The transceiver under test must be in a local U-loopback mode.

† 3 mW should be added for 85 °C.

‡ Anticipated customer configuration.

The conditions and test results in Method C are the product of recent investigations into the device's mature test data. They can be used to reliably determine system-level power consumption requirements.

**Method C**

Test Condition	Value
Loop Configuration	0 kft*
Temperature	25 °C†
Power Supply Voltage	5 V
CKOUT	3-stated‡
Max. Power Consumption	300 mW

\* This is the worst-case loop.

† 3 mW should be added for 85 °C.

‡ Anticipated customer configuration.

## Appendix B. Differences Between the T-7264- -ML, T-7264- -ML2, and T-7264A- -ML Devices

### Technology

The T-7264- -ML device is a 0.9  $\mu\text{m}$  CMOS technology device, while the T-7264- -ML2 and the T-7264A- -ML are 0.6  $\mu\text{m}$  CMOS technology devices.

### Standard

In 1996, the European Telecommunications Standards Institute (ETSI) added a microinterruption immunity requirement to ETR 080 (Sections 5.4.5 and 6.2.5).

Section 5.4.5 in ETSI ETR 080 states the following:

- A microinterruption is a temporary line interruption due to external mechanical activity on the copper wires constituting the transmission path.
- The effect of a microinterruption on the transmission system can be a failure of the digital transmission link.
- The objective of this requirement is that the presence of a microinterruption of specified maximum length shall not deactivate the system, and the system shall activate if it has deactivated due to longer interruption.

Section 6.2.5 in ETSI ETR 080 states the following:

- A system shall tolerate a microinterruption up to  $t = 5$  ms, when simulated with a repetition interval of  $t = 5$  ms.

Since this is a new requirement, implementers were allowed until the end of 1997 to adhere to this requirement. The T7264 device was upgraded to fully comply with this standard and the device was given an A suffix (T7264A).

A proposal was added to the Living List (which is intended to collect issues and observations for a possible future update of ETSI ETR 080) to change the value of the microinterruption requirement from 5 ms to 10 ms. The current T7264A device from Lucent Technologies Microelectronics Group meets and exceeds this new requirement.

The above change to the transceiver has been fully verified, and test reports are available upon request.

---

For additional information, contact your Microelectronics Group Account Manager or the following:

INTERNET: <http://www.lucent.com/micro>

E-MAIL: [docmaster@micro.lucent.com](mailto:docmaster@micro.lucent.com)

N. AMERICA: Microelectronics Group, Lucent Technologies Inc., 555 Union Boulevard, Room 30L-15P-BA, Allentown, PA 18103  
**1-800-372-2447**, FAX 610-712-4106 (In CANADA: **1-800-553-2448**, FAX 610-712-4106)

ASIA PACIFIC: Microelectronics Group, Lucent Technologies Singapore Pte. Ltd., 77 Science Park Drive, #03-18 Cintech III, Singapore 118256  
**Tel. (65) 778 8833**, FAX (65) 777 7495

CHINA: Microelectronics Group, Lucent Technologies (China) Co., Ltd., A-F2, 23/F, Zao Fong Universe Building, 1800 Zhong Shan Xi Road, Shanghai 200233 P. R. China **Tel. (86) 21 6440 0468, ext. 316**, FAX (86) 21 6440 0652

JAPAN: Microelectronics Group, Lucent Technologies Japan Ltd., 7-18, Higashi-Gotanda 2-chome, Shinagawa-ku, Tokyo 141, Japan  
**Tel. (81) 3 5421 1600**, FAX (81) 3 5421 1700

EUROPE: Data Requests: MICROELECTRONICS GROUP DATALINE: **Tel. (44) 1189 324 299**, FAX (44) 1189 328 148

Technical Inquiries: GERMANY: **(49) 89 95086 0** (Munich), UNITED KINGDOM: **(44) 1344 865 900** (Bracknell),

FRANCE: **(33) 1 41 45 77 00** (Paris), SWEDEN: **(46) 8 600 7070** (Stockholm), FINLAND: **(358) 9 4354 2800** (Helsinki),  
ITALY: **(39) 2 6601 1800** (Milan), SPAIN: **(34) 1 807 1441** (Madrid)

---

Lucent Technologies Inc. reserves the right to make changes to the product(s) or information contained herein without notice. No liability is assumed as a result of their use or application. No rights under any patent accompany the sale of any such product(s) or information.

