

## CelXpres™ T8207 ATM Interconnect

### 1 Product Overview

#### 1.1 Features

- > OC-3 transport capability
- UTOPIA level 1 and 2 (8-bit) cell-level handshake interface (ATM or PHY layers)
- 32 multi-PHY (MPHY) operation
- Shared UTOPIA mode
- Egress SDRAM buffer support to expand UTOPIA output priority queues for 32K to 512K cells:
  - 64 queues configurable up to four queues per PHY with programmable sizes
  - Programmable number of UTOPIA output queues with four levels of priority
- Support of ATM traffic management via partial packet discard (PPD), forward explicit congestion notification (FECN), and the cell loss priority (CLP) bit
- Programmable slew rate GTL+ I/O:
  - 1.7 Gbits/s cell bus operation
  - Programmable as bus arbiter
- Flexible per port cell counters
- Cell header translation and insertion with virtual path identifier (VPI) and virtual channel identifier (VCI) via external SRAM (up to 64K entries)
- Support of network node interface (NNI) and user network interface (UNI) header types with optional generic flow control (GFC) insertion
- Programmable operations and maintenance and resource management (OAM/RM) cell routing
- Support of multicast and broadcast cells per PHY

- Programmable priority for control/data cells transmission onto cell bus
- Eight GPIO pins
- JTAG support
- Optional monitoring of misrouted cells
- Microprocessor interface, supporting both *Motorola*® and *Intel*® modes (multiplexed and nonmultiplexed)
- Control cell transmission and reception through microprocessor port
- Single 3.3 V power supply
- 3.3 V TTL I/O (5 V tolerant)
- 272-pin PBGA package
- Industrial temperature range (–40 °C to +85 °C)
- Hot insertion capability
- Compatible with *Transwitch CellBus*®

#### 1.2 Applications

- Asymmetric digital subscriber line (ADSL) digital subscriber line access multiplexer (DSLAMs)
- Access gateways
- Access multiplexers/concentrators
- Multiservice access equipment platforms

**Table of Contents**

<b>Contents</b>	<b>Page</b>
1 Product Overview.....	1
1.1 Features .....	1
1.2 Applications .....	1
1.3 Description .....	8
1.4 Conventions .....	11
1.5 Glossary .....	12
2 Pin Description .....	13
3 Powerup/Reset Sequence .....	20
4 Hot Insertion.....	21
5 PLL Configuration .....	22
6 Microprocessor Interface .....	23
6.1 Microprocessor Interface Configuration .....	23
6.2 Microprocessor Interrupts.....	23
6.3 Accessing the <i>CelXpres</i> T8207 via Microprocessor Interface.....	23
6.3.1 Accessing the Extended Memory Registers.....	24
6.3.1.1 Extended Memory Writes.....	24
6.3.1.2 Extended Memory Reads.....	24
6.3.2 <i>CelXpres</i> T8207 Access Performance .....	25
7 General-Purpose I/O (GPIO) .....	26
8 Look-Up Table .....	27
8.1 Look-Up Table RAM.....	27
8.2 Organization .....	28
8.3 Look-Up Procedure .....	33
8.4 Extended Records.....	36
8.5 Diagnostics.....	41
8.6 Setup.....	41
9 UTOPIA Interface.....	42
9.1 Incoming UTOPIA Cell Interface .....	43
9.1.1 Incoming PHY Mode (Cells Received by T8207) .....	43
9.1.2 Incoming ATM Mode (Cells Received by T8207).....	43
9.2 Outgoing UTOPIA Cell Interface .....	44
9.2.1 Outgoing PHY Mode (Cells Sent by T8207).....	44
9.2.2 Outgoing ATM Mode (Cells Sent by T8207) .....	45
9.3 Counters.....	46
9.4 55-Byte UTOPIA Mode.....	47
9.5 Shared UTOPIA Mode .....	48
9.6 UTOPIA Pin Modes .....	50
9.7 UTOPIA Clocking .....	53
10 Cell Bus Interface.....	54
10.1 General Architecture .....	54
10.2 Cell Bus Frames.....	56
10.3 Cell Bus Routing Headers .....	59
10.3.1 Control Cells.....	59
10.3.2 Data Cells.....	60
10.3.3 Loopback Cells.....	60
10.3.4 Multicast Routing.....	60
10.3.5 Broadcast Routing.....	61
10.4 Cell Bus Arbitration.....	61
10.5 Cell Bus Monitoring .....	62
10.6 GTL+ Logic.....	62
10.7 Cell Bus Write and Read Clocks .....	63

Table of Contents (continued)

Contents	Page
11 SDRAM Interface.....	64
11.1 Memory Configuration.....	64
11.2 Powerup Sequence.....	64
11.3 SDRAM Interface Timing .....	65
11.4 Queuing .....	66
11.5 SDRAM Refresh .....	72
11.6 SDRAM Throughput.....	73
12 Traffic Management.....	74
12.1 Cell Loss Priority (CLP).....	74
12.2 Forward Explicit Congestion Notification (FECN) .....	74
12.3 Partial Packet Discard (PPD).....	74
13 JTAG Test Access Port .....	75
13.1 Instruction Register .....	75
13.2 Boundary-Scan Register .....	76
14 Registers.....	79
14.1 Register Types.....	79
14.2 Direct Memory Access Registers.....	82
14.2.1 Little-Endian Format (big_end = 0) for Extended Memory Access Registers 30h—37h .....	86
14.2.2 Big-Endian Format (big_end = 1) for Extended Memory Access Registers 30h—37h .....	88
14.2.3 General-Purpose I/O Control Registers .....	90
14.2.4 Control Cells .....	91
14.2.5 Multicast Memories .....	92
14.3 Extended Memory Registers.....	93
14.3.1 Main Registers .....	93
14.3.2 UTOPIA Registers .....	106
14.3.2.1 TX UTOPIA Configuration .....	108
14.3.2.2 TX UTOPIA Monitoring .....	125
14.3.2.3 RX UTOPIA Monitoring.....	126
14.3.3 SDRAM Registers.....	128
14.3.3.1 SDRAM Control Memory .....	135
14.3.4 Various Internal Memories .....	137
14.3.4.1 Control Cell Memories .....	137
14.3.4.2 Multicast Number Memories .....	138
14.3.4.3 PPD State Memory .....	140
14.3.5 External Memories.....	141
14.3.5.1 Look-Up Translation Memory .....	141
14.3.5.2 SDRAM Buffer Memory .....	141
15 Absolute Maximum Ratings.....	142
16 Recommended Operating Conditions.....	142
17 Handling Precautions.....	142
18 Electrical Requirements and Characteristics .....	143
18.1 Crystal Information.....	143
18.2 dc Electrical Characteristics .....	144
19 Timing Requirements.....	145
19.1 Microprocessor Interface Timing.....	146
19.2 UTOPIA Timing.....	152
19.3 External LUT Memory Timing .....	153
19.4 Cell Bus Timing.....	155
19.5 SDRAM Interface Timing .....	156
20 Outline Diagram.....	157
21 Ordering Information.....	158

**Table of Contents** (continued)

<b>Figure</b>	<b>Page</b>
Figure 1. Functional Block Diagram .....	9
Figure 2. Dual Bus Implementation .....	10
Figure 3. 272-Pin PBGA—Top View .....	19
Figure 4. Translation RAM Memory Map—8-Byte Records, for Up to 16 Ports .....	29
Figure 5. Translation RAM Memory Map—8-Byte Records, for Greater than 16 Ports.....	30
Figure 6. Translation Record Types—8-Byte Records.....	31
Figure 7. Translation RAM Flow Diagram .....	35
Figure 8. Translation Record Types—Extended Mode .....	37
Figure 9. Translation RAM Memory Map—Extended Mode, for Up to 16 Ports.....	38
Figure 10. Translation RAM Memory Map—Extended Mode, for Greater than 16 Ports .....	39
Figure 11. Queue Priority Multiplexing .....	46
Figure 12. TX UTOPIA Cell Handling .....	47
Figure 13. TX UTOPIA Bus Sharing.....	49
Figure 14. Cell Bus Frame Format (Bit Positions for 16 User Mode) .....	56
Figure 15. Cell Bus Frame Format (Bit Positions for 32 User Mode) .....	57
Figure 16. Cell Bus Routing Headers .....	59
Figure 17. GTL+ External Circuitry .....	62
Figure 18. SDRAM Timing Parameters .....	65
Figure 19. Crystal .....	143
Figure 20. Negative Resistance Plot .....	143
Figure 21. Nonmultiplexed <i>Intel</i> Mode Write Access Timing .....	146
Figure 22. Nonmultiplexed <i>Intel</i> Mode Read Access Timing.....	146
Figure 23. <i>Motorola</i> Mode Write Access Timing.....	148
Figure 24. <i>Motorola</i> Mode Read Access Timing .....	148
Figure 25. Multiplexed <i>Intel</i> Mode Write Access Timing.....	150
Figure 26. Multiplexed <i>Intel</i> Mode Read Access Timing .....	150
Figure 27. External LUT Memory Read Timing (cyc_per_acc = 2 and cyc_per_acc = 3) .....	153
Figure 28. External LUT Memory Write Timing (cyc_per_acc = 2 and cyc_per_acc = 3) .....	153
Figure 29. Cell Bus Timing .....	155
Figure 30. SDRAM Interface Timing.....	156

Table of Contents (continued)

Table	Page
Table 1. UTOPIA Pins .....	13
Table 2. Cell Bus Pins .....	14
Table 3. SDRAM Interface Pins .....	15
Table 4. Microprocessor Interface Pins .....	16
Table 5. Translation SRAM Interface .....	17
Table 6. JTAG Pins .....	17
Table 7. General-Purpose Pins .....	18
Table 8. Power Pins .....	18
Table 9. Loop Filter Register Settings .....	22
Table 10. Access Times .....	25
Table 11. Active and Ignore Truth Table .....	31
Table 12. VPI Value Truth Table .....	32
Table 13. OAM Routing Control Truth Table .....	32
Table 14. F5 Translation Record Addresses Table—8-Byte Records .....	33
Table 15. F5 Translation Record Addresses Table—Extended Mode .....	40
Table 16. Port Numbering for MPHY Configurations .....	51
Table 17. Supported Memory Configurations .....	64
Table 18. Queue Organization and Port Group Address/Priority Bits for 16 Ports with T8207_sel = 1 .....	67
Table 19. Queue Organization and Port Group Address/Priority Bits for 32 Ports .....	69
Table 20. Queue Organization and Port Group Address/Priority Bits for 16 Ports with T8207_sel = 0.....	71
Table 21. Instruction Register .....	75
Table 22. Boundary-Scan Register Descriptions .....	76
Table 23. Register Map .....	79
Table 24. Identification 0 (IDNT0) (00h) .....	82
Table 25. Identification 1 (IDNT1) (01h).....	82
Table 26. Identification 2 (IDNT2) (02h) .....	82
Table 27. Direct Configuration/Control Register (DCCR) (28h) .....	83
Table 28. Interrupt Service Request (ISREQ) (29h) .....	84
Table 29. mclk PLL Configuration 0 (MPLLCF0) (2Ah) .....	84
Table 30. mclk PLL Configuration 1 (MPLLCF1) (2Bh) .....	85
Table 31. GTL+ Slew Rate Configuration (GTLSRCF) (2Eh) .....	85
Table 32. GTL+ Control (GTLCNTRL) (2Fh).....	85
Table 33. Extended Memory Address 1 (Little Endian) (EMA1_LE) (30h).....	86
Table 34. Extended Memory Address 2 (Little Endian) (EMA2_LE) (31h).....	86
Table 35. Extended Memory Address 3 (Little Endian) (EMA3_LE) (32h).....	86
Table 36. Extended Memory Address 4 (Little Endian) (EMA4_LE) (33h).....	86
Table 37. Extended Memory Access (Little Endian) (EMA_LE) (34h) .....	86
Table 38. Extended Memory Data Low (Little Endian) (EMDL_LE) (36h) .....	87
Table 39. Extended Memory Data High (Little Endian) (EMDH_LE) (37h) .....	87
Table 40. Extended Memory Address 4 (Big Endian) (EMA4_BE) (30h).....	88
Table 41. Extended Memory Address 3 (Big Endian) (EMA3_BE) (31h).....	88
Table 42. Extended Memory Address 2 (Big Endian) (EMA2_BE) (32h).....	88
Table 43. Extended Memory Address 1 (Big Endian) (EMA1_BE) (33h).....	88
Table 44. Extended Memory Access (Big Endian) (EMA_BE) (34h) .....	89
Table 45. Extended Memory Data High (Big Endian) (EMDH_BE) (36h) .....	89
Table 46. Extended Memory Data Low (Big Endian) (EMDL_BE) (37h) .....	89
Table 47. GPIO Output Enable (GPIO_OE) (39h) .....	90
Table 48. GPIO Output Value (GPIO_OV) (3Bh).....	90

**Table of Contents** (continued)

<b>Table</b>	<b>Page</b>
Table 49. GPIO Input Value (GPIO_IV) (3Dh).....	90
Table 50. Control Cell Receive Direct Memory (CCRXDM) (60h to 93h).....	91
Table 51. Control Cell Transmit Direct Memory (CCTXDM) (A0h to D7h).....	91
Table 52. PHY Port 0 and Control Cells Multicast Direct Memory (PP0MDM) (E0h to FFh).....	92
Table 53. Main Configuration 1 (MCF1) (0100h).....	93
Table 54. Main Interrupt Status 1 (MIS1) (0102h).....	94
Table 55. Main Interrupt Enable 1 (MIE1) (0104h).....	95
Table 56. TX UTOPIA Clock Configuration (TXUCCF) (010Ch).....	96
Table 57. RX UTOPIA Clock Configuration (RXUCCF) (010Eh).....	97
Table 58. Main Configuration/Control (MCFCT) (0110h).....	98
Table 59. Main Configuration 2 (MCF2) (0112h).....	98
Table 60. UTOPIA Configuration (UCF) (0114h).....	100
Table 61. Main Configuration 3 (MCF3) (0116h).....	100
Table 62. Loopback (LB) (0118h).....	101
Table 63. UTOPIA Configuration 3 (UCF3) (011Ah).....	101
Table 64. UTOPIA Configuration 2 (UCF2) (011Ch).....	101
Table 65. Extended LUT Configuration (ELUTCF) (011Eh).....	101
Table 66. Extended LUT Control (ELUTCN) (0120h).....	102
Table 67. Cell Bus Configuration/Status (CBCFS) (0130h).....	103
Table 68. Main Interrupt Status 2 (MIS2) (0132h).....	103
Table 69. Main Interrupt Enable 2 (MIE2) (0134h).....	104
Table 70. Misrouted LUT 1 (MLUT1) (0142h).....	105
Table 71. Misrouted LUT 2 (MLUT2) (0144h).....	105
Table 72. Misrouted Cell Header High (MCHH) (0146h).....	105
Table 73. Misrouted Cell Header Low (MCHL) (0148h).....	105
Table 74. HEC Interrupt Status 1 (HIS1) (0302h).....	106
Table 75. HEC Interrupt Enable 1 (HIE1) (0304h).....	106
Table 76. HEC Interrupt Status (HIS) (0306h).....	106
Table 77. HEC Interrupt Enable (HIE) (0308h).....	106
Table 78. LUT Interrupt Service Request (LUTISR) (030Eh).....	106
Table 79. LUT X Configuration/Status (LUTXCFS) (0320h to 033Eh).....	107
Table 80. Master Queue 3 (MQ3) (0158h).....	108
Table 81. Master Queue 2 (MQ2) (015Ah).....	108
Table 82. Master Queue 0 (MQ0) (015Ch).....	109
Table 83. Master Queue 1 (MQ1) (015Eh).....	109
Table 84. Slave Queue 0 (SQ0) (016Ch).....	110
Table 85. Slave Queue 1 (SQ1) (016Eh).....	110
Table 86. TX PHY FIFO Routing 3 (TXPFR3) (0178h).....	111
Table 87. TX PHY FIFO Routing 2 (TXPFR2) (017Ah).....	112
Table 88. TX PHY FIFO Routing 0 (TXPFR0) (017Ch).....	113
Table 89. TX PHY FIFO Routing 1 (TXPFR1) (017Eh).....	114
Table 90. Routing Information 1 (RI1) (0200h).....	115
Table 91. Routing Information 2 (RI2) (0202h).....	116
Table 92. Routing Information 3 (RI3) (0204h).....	117
Table 93. PPD Information 1 (PPDI1) (0206h).....	118
Table 94. PPD Information 2 (PPDI2) (0208h).....	119
Table 95. PPD Information 3 (PPDI3) (020Ah).....	120
Table 96. PPD Information 4 (PPDI4) (020Ch).....	121
Table 97. PPD Information 5 (PPDI5) (020Eh).....	122
Table 98. PPD Information 6 (PPDI6) (0210h).....	123
Table 99. PPD Information 7 (PPDI7) (0212h).....	124

Table of Contents (continued)

Table	Page
Table 100. PPD Memory Write (PPDMW) (0418h) .....	124
Table 101. PHY Port X Transmit Count Structure (PPXTXCNT) (0600h to 067Ch) .....	125
Table 102. PHY Port X Receive Count Structure (PPXRCNT) (0700h to 07F8h) .....	126
Table 103. LUT X Configuration 1 Structure (LUTXCF1) (0704h to 077Ch).....	127
Table 104. SDRAM Control (SCT) (0400h) .....	128
Table 105. SDRAM Interrupt Status (SIS) (0402h) .....	128
Table 106. SDRAM Interrupt Enable (SIE) (0404h) .....	128
Table 107. SDRAM Configuration (SCF) (0408h) .....	129
Table 108. Refresh (RFRSH) (0410h) .....	130
Table 109. Refresh Lateness (RFRSHL) (0412h) .....	130
Table 110. Idle State 1 (IS1) (0420h) .....	130
Table 111. Idle State 2 (IS2) (0422h) .....	130
Table 112. Manual Access State 1 (MAS1) (0424h) .....	131
Table 113. Manual Access State 2 (MAS2) (0426h) .....	131
Table 114. SDRAM Interrupt Service Request 4 (SISR4) (0438h).....	132
Table 115. SDRAM Interrupt Service Request 3 (SISR3) (043Ah).....	132
Table 116. SDRAM Interrupt Service Request 1 (SISR1) (043Ch) .....	132
Table 117. SDRAM Interrupt Service Request 2 (SISR2) (043Eh) .....	132
Table 118. Queue X (QX) (0440h to 04BEh) .....	133
Table 119. Queue X Definition Structure (QXDEF) (2000h to 27E0h).....	135
Table 120. Control Cell Receive Extended Memory (CCRXEM) (0800h to 0832h).....	137
Table 121. Control Cell Transmit Extended Memory (CCTXEM) (0900h to 0936h) .....	137
Table 122. PHY Port 0 and Control Cells Multicast Extended Memory (PP0MEM) (0C00h to 0C1Eh).....	138
Table 123. PHY Port X Multicast Memory (PPXMM) (0C20h to 0DE0h) .....	139
Table 124. PPD Memory (PPDM) (1000h to 13FEh) .....	140
Table 125. Translation RAM Memory (TRAM) (100000h to 17FFFEh) .....	141
Table 126. SDRAM (SDRAM) (2000000h to 3FFFFFFEh) .....	141
Table 127. Maximum Rating Parameters and Values.....	142
Table 128. Recommended Operating Conditions .....	142
Table 129. HBM ESD Threshold.....	142
Table 130. Crystal Specifications .....	143
Table 131. External Clock Requirements.....	143
Table 132. dc Electrical Characteristics .....	144
Table 133. Input Clocks .....	145
Table 134. Output Clocks .....	145
Table 135. Nonmultiplexed <i>Intel</i> Mode Write Access Timing .....	147
Table 136. Nonmultiplexed <i>Intel</i> Mode Read Access Timing .....	147
Table 137. <i>Motorola</i> Mode Write Access Timing .....	149
Table 138. <i>Motorola</i> Mode Read Access Timing .....	149
Table 139. Multiplexed <i>Intel</i> Mode Write Access Timing .....	151
Table 140. Multiplexed <i>Intel</i> Mode Read Access Timing .....	151
Table 141. TX UTOPIA Timing (70 pF Load on Outputs) .....	152
Table 142. RX UTOPIA Timing (70 pF Load on Outputs) .....	152
Table 143. External LUT Memory Read Timing (cyc_per_acc = 2) .....	154
Table 144. External LUT Memory Read Timing (cyc_per_acc = 3) .....	154
Table 145. External LUT Memory Write Timing (cyc_per_acc = 2) .....	154
Table 146. External LUT Memory Write Timing (cyc_per_acc = 3) .....	154
Table 147. Cell Bus Timing .....	155
Table 148. SDRAM Interface Timing .....	156

## **1 Product Overview** (continued)

### **1.3 Description**

The *CelXpres* T8207 device integrates all of the required functionality to transport ATM cells across a backplane architecture with high-speed cell traffic exceeding 1.5 Gbits/s to a maximum of 32 destinations. The management of multiple service categories and monitoring of performance on ATM and PHY interfaces is incorporated in the device's functionality. Traffic delivery to multi-PHYs (MPHYs) is managed through the UTOPIA interface.

The T8207 device meets the ATM Forum's universal test and operations PHY interface for ATM (UTOPIA) Level 1, Version 2.01 and Level 2, Version 1.0 specifications for cell-level handshake and MPHY data path operation with rates up to 353 Mbits/s. The T8207 supports the required MPHY operation as described in Sections 4.1 and 4.2 of the ATM Forum's Level 2 specification. The T8207 supports MPHY operation with one transmit cell available (TxCLAV) signal and one receive cell available (RxCLAV) signal for up to 16 PHY ports for an 8-bit UTOPIA 2 interface configuration. With two transmit cells available/enable (TxCLAV/enb\*) pairs of signals and receive cells available/enable (RxCLAV/enb\*) pairs of signals, 32 MPHYs can be supported. In addition to the required UTOPIA signals, the optional transmit parity (TxPRTY) and receive parity (RxPRTY) signals are provided.

The T8207 may be configured as an ATM or PHY level device providing cell routing between UTOPIA and a 32-bit wide cell bus. In addition to the 32 data signals, the bus has the following signals:

- Read clock
- Write clock
- Frame sync
- Acknowledge

ATM cells arriving from the UTOPIA interface may get VPI and VCI translation and routing information from a look-up table in external SRAM. An external synchronous dynamic random access memory (SDRAM) is used to extend the buffering for ATM cells destined for the UTOPIA interface. This external SDRAM may be partitioned into four or less independently sized queues per PHY for a configuration of 16 MPHYs and two queues per PHY or a programmable number of queues per PHY for a configuration of 32 MPHYs. The number of cells per queue per PHY is programmable. The four queues may be used to implement quality of service (QoS) using different priorities for each queue.

The *CelXpres* T8207 provides a shared UTOPIA mode, which allows two devices on different cell buses to share the same UTOPIA bus in ATM mode. Using a glueless interface, the two T8207 devices resolve queue priorities and arbitrate the use of the UTOPIA bus. This shared mode can be used to provide redundancy or increase UTOPIA traffic capacity by supporting traffic from multiple cell buses.

The *CelXpres* T8207 supports the transport of control and loopback cells with an external microprocessor. Control or loopback cells may be sent or received through the microprocessor interface. The 8-bit microprocessor interface may be configured to be *Motorola* or *Intel* compatible and is used to configure and monitor the device.



1 Product Overview (continued)

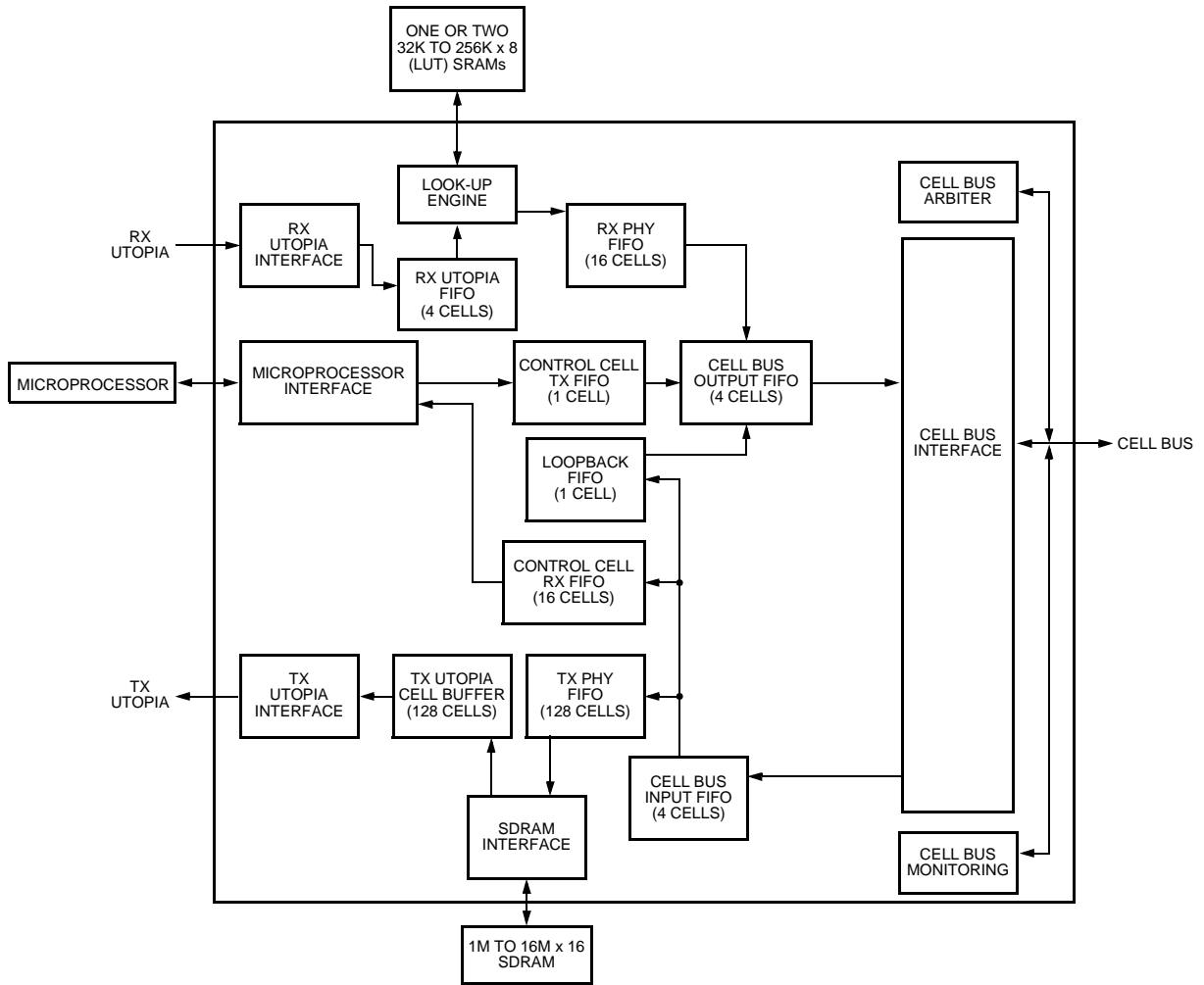
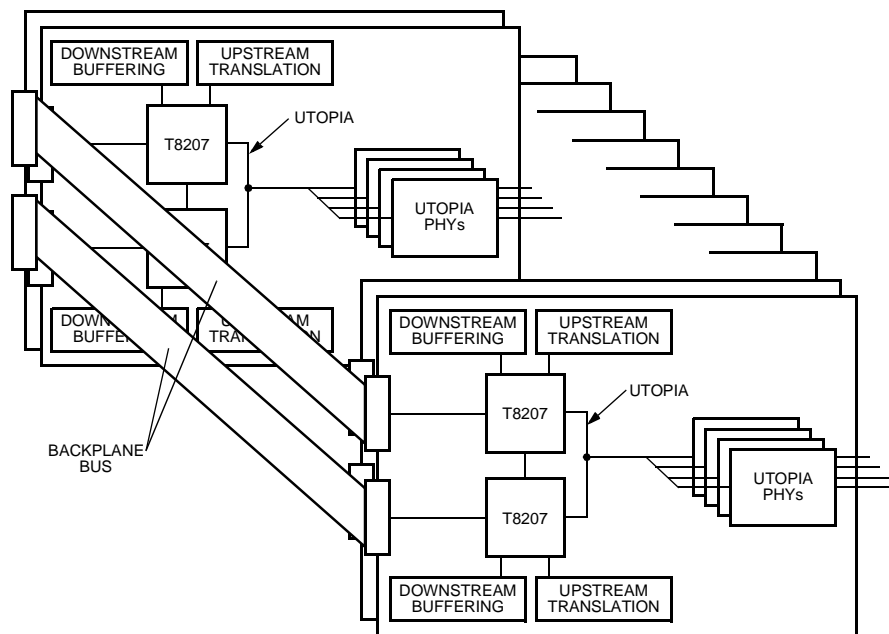

Figure 1. Functional Block Diagram

5-7542E (F)

**1 Product Overview** (continued)

Figure 2 illustrates the use of the *CelXpres* T8207 in a system with dual backplane cell buses using shared UTOPIA mode. In this configuration, both T8207 devices on each card receive cells from the UTOPIA bus, and each device uses its translation table to determine if the cell should be transmitted on its backplane cell bus. In the egress direction, each T8207 device receives cells from its cell bus to transmit on the UTOPIA bus. MPHY arbitration and queue priorities are resolved using a two-wire interface between the two devices. Although a single ATM virtual connection is not typically established on both backplane cell buses simultaneously, no restrictions exist for a single PHY utilizing both backplane cell buses for different virtual connections supporting higher throughput from two bus interfaces. Redundant bus configurations can be supported in the event of a bus failure with T8207 devices by configuring one device to assume bus responsibility from the other.



**Figure 2. Dual Bus Implementation**

0041

## 1 Product Overview (continued)

### 1.4 Conventions

- All numbers in this document are decimals unless otherwise specified.
- Hexadecimal numbers can be identified by the 'h' suffix, e.g., A5h.
- Binary numbers are either in double quotes for multiple bits or in single quotes for individual bits, e.g., "1001" and '0.'
- A byte is 8 bits, a word is 16 bits, and a double word (dword) is 32 bits.
- A binary value of '1' is high, and a binary value of '0' is low.
- To clear is to change one or multiple bit values to '0.'
- To set is to change one or multiple bit values to '1.'
- All memory addresses are specified in hexadecimal.
- Addresses are converted from bytes to words or double words using the little-endian format, unless otherwise specified.
- A signal name with a trailing asterisk is active-low, e.g., sd\_we\*.
- Bits y to x will be designated bits (y:x).

## **1 Product Overview** (continued)

### **1.5 Glossary**

**Bus Cell:**

Major content of the cell bus frame consisting of 56 bytes, 4 bytes for routing options and 52 bytes for the ATM cell content, which excludes the HEC. The bus cell is preceded by the 4 bytes of request and followed by the 4 bytes of grant and parity information.

**CLP:**

Cell loss priority. The CLP is a 1-bit field in the cell header that becomes set when the cell violates the negotiated quality of service parameters.

**EFCI:**

Explicit forward congestion indication. The EFCI is a 1-bit field in the PTI field of the cell header that becomes set when the cell encounters congestion.

**FECN:**

Forward explicit congestion notification. FECN is a method used by the network to signal to the destination when congestion is encountered. The EFCI bit is used to indicate the congestion.

**GFC:**

Generic flow control. The GFC is a 4-bit field in the cell header that may be used by a UNI to support traffic and congestion control. Typically, this field is programmed to "0000" indicating that generic flow control is not supported. GFC may be used in priority protocols.

**Grant Section:**

Last 4 bytes of the cell bus frame. The grant section occurs during the last clock cycle of the cell bus frame. During this cycle, the cell bus arbiter indicates which T8207 may transmit during the next bus cell unit of the cell bus frame. A parity vector is also transmitted during the grant section.

**HEC:**

Header error control. The HEC is a 1-byte field in the cell header used for bit error detection and correction in the header.

**NNI:**

Network node interface. The NNI is the interface between nodes in the public network.

**OAM Cell:**

Operations and maintenance cell. An OAM cell carries local management information.

**PPD:**

Partial packet discard. PPD is a technique to relieve congestion. When one cell in a packet is lost, all remaining cells in the packet, except the last, are discarded.

**PTI:**

Payload type identifier. The PTI is a 3-bit field in the cell header containing information about the type of data (user, OAM, or traffic management) and about encountered congestion.

**QoS:**

Quality of service. Quality of service parameters define the performance requirements and characteristics for traffic on an assigned channel. Some parameters include cell loss ratio, cell transfer delay, cell delay variation, peak cell rate, and sustained cell rate.

**RM:**

Resource management. RM is the local management of network resources.

**RxCLAV:**

Receive cell available signal as described in the ATM Forum's universal test and operations PHY interface for ATM (UTOPIA) Level 1, Version 2.01 and Level 2, Version 1.0 specifications.

**RxENB:**

Receive enable signal as described in the ATM Forum's universal test and operations PHY interface for ATM (UTOPIA) Level 1, Version 2.01 and Level 2, Version 1.0 specifications.

**TxCLAV:**

Transmit cell available signal as described in the ATM Forum's universal test and operations PHY interface for ATM (UTOPIA) Level 1, Version 2.01 and Level 2, Version 1.0 specifications.

**TxENB:**

Transmit enable signal as described in the ATM Forum's universal test and operations PHY interface for ATM (UTOPIA) Level 1, Version 2.01 and Level 2, Version 1.0 specifications.

**UNI:**

User network interface. The UNI is the interface between a private network node and a public network node.

**VCI:**

Virtual channel identifier. The VCI is a 2-byte field in the cell header that identifies the virtual channel used by the cell.

**VPI:**

Virtual path identifier. The VPI is an 8-bit field in the UNI cell header or a 12-bit field in the NNI cell header that identifies the virtual path of the cell.

## 2 Pin Description

This section defines the *CelXpres* T8207 pins. All TTL compatible inputs or I/O are 5 V tolerant. No GTL+ inputs or I/O are 5 V tolerant.

Table 1. UTOPIA Pins

Symbol	Ball	Reset Value	Type	Name/Description
u_rxaddr[4:0]	R2, P3, R1, P2, P1	Z	I/O	<b>RX UTOPIA Address Lines.</b> 10 mA drive, TTL compatible I/O, 5 V tolerant.
u_rxdata[7:0]	V2, U3, T4, V1, U2, T3, U1, T2	—	I	<b>RX UTOPIA Data Lines.</b> TTL compatible input, 5 V tolerant.
u_rxclk	T1	Z	I/O	<b>RX UTOPIA Clock.</b> 10 mA drive, TTL compatible I/O, 5 V tolerant.
u_rxsoc	P4	—	I	<b>RX UTOPIA Start of Cell (Active-High).</b> TTL compatible input, 5 V tolerant.
u_rxclav[0]	L4	Z	I/O	<b>RX UTOPIA PHY 0 Cell Available (Active-High).</b> Main RX cell available in single PHY mode. 10 mA drive, TTL compatible I/O, 5 V tolerant. This pin has an internal 50 k $\Omega$ pull-up resistor.
u_rxclav[3:1]	M3, M2, M1	—	I	<b>RX UTOPIA Cell Available Lines (Active-High).</b> TTL compatible input, 5 V tolerant. These pins have an internal 50 k $\Omega$ pull-up resistor.
u_rxenb*[0]	M4	Z	I/O	<b>RX UTOPIA PHY 0 Enable (Active-Low).</b> Main RX enable in single PHY mode. 10 mA drive, TTL compatible I/O, 5 V tolerant.
u_rxenb*[3:1]	N3, N2, N1	Z	I/O	<b>RX UTOPIA PHY Enable Lines (Active-Low).</b> 10 mA drive, TTL compatible I/O, 5 V tolerant.
u_rxprty	R3	—	I	<b>RX UTOPIA Odd Parity.</b> TTL compatible input, 5 V tolerant. This pin has an internal 50 k $\Omega$ pull-up resistor.
u_txaddr[4:0]	P17, R19, R20, P18, P19	Z	I/O	<b>TX UTOPIA Address Lines.</b> 10 mA drive, TTL compatible I/O. 5 V tolerant.
u_txdata[7:0]	W20, V19, U19, U18, T17, V20, U20, T18	Z	O	<b>TX UTOPIA Data Lines.</b> 10 mA drive, TTL compatible output.
u_txclk	R18	Z	I/O	<b>TX UTOPIA Clock.</b> 10 mA drive, TTL compatible I/O, 5 V tolerant.
u_txsoc	T20	Z	O	<b>TX UTOPIA Start of Cell (Active-High).</b> 10 mA drive, TTL compatible output.
u_txclav[0]	M20	Z	I/O	<b>TX UTOPIA PHY 0 Cell Available (Active-High).</b> Main TX cell available in single PHY mode. 10 mA drive, TTL compatible I/O. 5 V tolerant. This pin has an internal 50 k $\Omega$ pull-up resistor.
u_txclav[3:1]	M17, M18, M19	—	I	<b>TX UTOPIA Cell Available Lines (Active-High).</b> TTL compatible input, 5 V tolerant. These pins have an internal 50 k $\Omega$ pull-up resistor.
u_txenb*[0]	N20	Z	I/O	<b>TX UTOPIA PHY 0 Enable (Active-Low).</b> Main TX enable in single PHY mode. 10 mA drive, TTL compatible I/O, 5 V tolerant.
u_txenb*[3:1]	P20, N18, N19	Z	O	<b>TX UTOPIA Enable Lines (Active-Low).</b> 10 mA drive, TTL compatible output.
u_txprty	T19	Z	O	<b>TX UTOPIA Odd Parity.</b> 10 mA drive, TTL compatible output.
u_shr_o	V16	1	O	<b>Shared UTOPIA Output.</b> Used as grant if device is shared UTOPIA master or as request if device is shared UTOPIA slave. 4 mA drive, TTL compatible output. This pin has an internal 50 k $\Omega$ pull-up resistor.
u_shr_i	W17	—	I	<b>Shared UTOPIA Input.</b> Used as request if device is shared UTOPIA master or as grant if chip is shared UTOPIA slave. TTL compatible input, 5 V tolerant. This pin has an internal 50 k $\Omega$ pull-up resistor.

## 2 Pin Description (continued)

Table 2. Cell Bus Pins

Symbol	Ball	Reset Value	Type	Name/Description
ua*[4:0]	B18, B17, C17, D16, A18	—	I	<b>Unit Address Lines (Active-Low).</b> Address assigned to device for cell bus identification. TTL compatible input, 5 V tolerant.
cb_d*[31:0]	B5, C6, D7, A5, B6, C7, A6, B7, A7, C8, B8, A8, D9, C9, B9, A9, A11, C11, B11, A12, B12, C12, D12, A13, B13, C13, A14, B14, C14, A15, B15, D14	Z	I/O	<b>Cell Bus Data Lines (Active-Low).</b> GTL+ I/O.
cb_wc*	A10	—	I	<b>Cell Bus Write Clock (Active-Low).</b> Uses falling edge to output data on cell bus. Write and read clocks have the same frequency but different phase. GTL+ input.
cb_rc*	B10	—	I	<b>Cell Bus Read Clock (Active-Low).</b> Uses falling edge to latch data from cell bus. Write and read clocks have the same frequency but different phase. GTL+ input.
cb_fs*	C15	Z	I/O	<b>Cell Bus Frame Sync (Active-Low).</b> GTL+ I/O.
cb_ack*	B16	Z	I/O	<b>Cell Bus Acknowledge Signal (Active-Low).</b> Driven low on cycle 0 of the following frame when a valid cell is received from the cell bus. This signal is not driven for broadcast or multicast cells. GTL+ I/O.
arb_en*	A17	—	I	<b>Cell Bus Arbiter Enable (Active-Low).</b> Cell bus arbiter enable. Only one device on the cell bus may be configured as arbiter. TTL-compatible input, 5 V tolerant. This pin has an internal 50 k $\Omega$ pull-up resistor.
cb_disable*	C16	—	I	<b>Cell Bus Disable (Active-Low).</b> CMOS input that 3-states all GTL+ outputs when low, but GTL+ buffer inputs are active. This pin has an internal 50 k $\Omega$ pull-up resistor.
cb_iref	A4	—	I	<b>Cell Bus Current Reference.</b> Precision current reference for GTL+ buffers. A 1 k $\Omega$ , 1% resistor must be connected between this pin and GND.
cb_vref	D10	—	I	<b>Cell Bus Voltage Reference.</b> GTL+ buffer threshold voltage reference (1.0 V typical). This voltage reference is $2/3 V_{TT}$ , created using a voltage divider of three 1 k $\Omega$ , 1% resistors between $V_{TT}$ and cb_vref_vss.
cb_vref_vss	C10	—	—	<b>Cell Bus Voltage Reference Ground.</b>

## 2 Pin Description (continued)

Table 3. SDRAM Interface Pins

Symbol	Ball	Reset Value	Type	Name/Description
sd_a[11:0]	L19, L18, L20, K20, K19, K18, K17, J20, J19, J18, J17, H20	X	O	<b>SDRAM Address Lines.</b> 7 mA drive, TTL compatible output. These buffers are 50 $\Omega$ impedance matching buffers. Long printed-wiring board traces should have 50 $\Omega$ nominal impedance.
sd_d[15:0]	F19, E20, G17, F18, E19, D20, E18, D19, C20, E17, D18, C19, B20, C18, B19, A20	Z	I/O	<b>SDRAM Data Lines.</b> 7 mA drive, TTL compatible I/O. These buffers are 50 $\Omega$ impedance matching buffers. Long printed-wiring board traces should have 50 $\Omega$ nominal impedance.
sd_bs[1:0]	H18, G20	X	O	<b>SDRAM Bank Selects.</b> 7 mA drive, TTL compatible output. These buffers are 50 $\Omega$ impedance matching buffers. Long printed-wiring board traces should have 50 $\Omega$ nominal impedance.
sd_ras*	G19	1	O	<b>SDRAM Row Address Select (Active-Low).</b> 7 mA drive, TTL compatible output. This buffer is a 50 $\Omega$ impedance matching buffer. Long printed-wiring board traces should have 50 $\Omega$ nominal impedance.
sd_cas*	F20	1	O	<b>SDRAM Column Address Select (Active-Low).</b> 7 mA drive, TTL compatible output. This buffer is a 50 $\Omega$ impedance matching buffer. Long printed-wiring board traces should have 50 $\Omega$ nominal impedance.
sd_we*	G18	1	O	<b>SDRAM Write Enable (Active-Low).</b> 7 mA drive, TTL compatible output. This buffer is a 50 $\Omega$ impedance matching buffer. Long printed-wiring board traces should have 50 $\Omega$ nominal impedance.
sd_clk	H19	Z	I/O	<b>SDRAM Clock.</b> 7 mA drive, TTL compatible output. This buffer is a 50 $\Omega$ impedance matching buffer. Long printed-wiring board traces should have 50 $\Omega$ nominal impedance.
sd_iref	A19	—	I	<b>SDRAM Current Reference.</b> Precision current reference for SDRAM buffers. A 1 k $\Omega$ , 1% resistor must be connected between this pin and GND.

## 2 Pin Description (continued)

Table 4. Microprocessor Interface Pins

Symbol	Ball	Reset Value	Type	Name/Description
a[7:1]	W6, Y6, V7, W7, Y7, V8, W8	—	I	<b>Microprocessor Port Address Lines.</b> Most significant 7 bits of the address bus. TTL compatible input, 5 V tolerant.
a[0]/ale	Y8	—	I	<b>Microprocessor Port Address 0/Address Latch Enable.</b> Least significant bit of the address bus in nonmultiplexed mode or address latch enable in multiplexed mode.
d[7:0]	U9, V9 W9, Y9, W10, V10, Y10, Y11	Z	I/O	<b>Microprocessor Port Data Lines.</b> 6 mA drive, TTL compatible I/O, 5 V tolerant.
sel*	W12	—	I	<b>Microprocessor Chip Select (Active-Low).</b> TTL compatible input, 5 V tolerant.
wr*_ds*	V12	—	I	<b>Microprocessor Write/Data Strobe.</b> Active-low write enable in <i>Intel</i> mode. Active-low data strobe in <i>Motorola</i> mode. TTL compatible input, 5 V tolerant.
rd*_rw*	U12	—	I	<b>Microprocessor Read/Write.</b> Active-low read enable in <i>Intel</i> mode, or read/write* enable in <i>Motorola</i> mode, where read is active-high and write is active-low. TTL compatible input, 5 V tolerant.
int_irq*	Y12	0/1	O	<b>CPU Interrupt.</b> Active-high in <i>Intel</i> mode and active-low in <i>Motorola</i> mode. 4 mA drive, TTL compatible output.
rdy_dtack*	U11	Z	O	<b>Ready/Data Transfer Acknowledge.</b> Active-high ready signal in <i>Intel</i> mode and active-low data transfer acknowledge in <i>Motorola</i> mode. Indicates access complete. 6 mA drive, TTL compatible output.
mot_sel	Y13	—	I	<b>Intel/Motorola Selection.</b> '0' = <i>Intel</i> , '1' = <i>Motorola</i> . TTL compatible input, 5 V tolerant.
mux	W13	—	I	<b>Microprocessor Multiplex Select.</b> Active-high for multiplex mode. TTL compatible input, 5 V tolerant.



## 2 Pin Description (continued)

Table 5. Translation SRAM Interface

Symbol	Ball	Reset Value	Type	Name/Description
tr_a[17:0]	L3, L2, L1, K1, K3, K2, J1, J2, J3, J4, H1, H2, H3, G1, G2, G3, F1, F2	X	O	<b>Translation RAM Address Lines.</b> 4 mA drive, TTL compatible output.
tr_d[7:0]	E3, D1, C1, E4, D3, D2, C2, B1	Z	I/O	<b>Translation RAM Data Lines.</b> 4 mA drive, TTL compatible I/O, 5 V tolerant.
tr_cs*[1:0]	E1, E2	1	O	<b>Translation RAM Chip Selects (Active-Low).</b> Chip selects to select one of two external SRAMs. For connection to one external device, tr_cs*[0] is used. 4 mA drive, TTL compatible output.
tr_oe*	F3	1	O	<b>External RAM Output Enable (Active-Low).</b> 4 mA drive, TTL compatible output.
tr_we*	G4	1	O	<b>External RAM Write Enable (Active-Low).</b> 4 mA drive, TTL compatible output.

Table 6. JTAG Pins

Symbol	Ball	Reset Value	Type	Name/Description
jtag_tdi	Y16	—	I	<b>Test Data Input (JTAG).</b> TTL compatible input, 5 V tolerant. This pin has an internal 50 k $\Omega$ pull-up resistor.
jtag_tdo	W16	X	O	<b>Test Data Output (JTAG).</b> 4 mA drive, TTL compatible output.
jtag_trst*	W15	—	I	<b>Test Reset (JTAG) (Active-Low).</b> Should be pulled low when part is in normal operation. TTL compatible input, 5 V tolerant. This pin has an internal 50 k $\Omega$ pull-up resistor.
jtag_tclk	V15	—	I	<b>Test Clock (JTAG).</b> TTL compatible input, 5 V tolerant. This pin has an internal 50 k $\Omega$ pull-up resistor.
jtag_tms	U14	—	I	<b>Test Mode Select (JTAG).</b> TTL compatible input, 5 V tolerant. This pin has an internal 50 k $\Omega$ pull-up resistor.

## 2 Pin Description (continued)

Table 7. General-Purpose Pins

Symbol	Ball	Reset Value	Type	Name/Description
gpio[7:0]	U5, Y3, Y4, V5, W5, Y5, V6, U7	—	I/O	<b>General-Purpose I/O.</b> 4 mA drive, TTL compatible I/O, 5 V tolerant.
reset*	V14	—	I	<b>Reset (Active-Low).</b> Schmitt trigger, TTL compatible input, 5 V tolerant.
xtalin	V13	—	I	<b>Crystal Input (pclk).</b> This input may be driven by either a crystal or an external clock. If a crystal is used, connect it between this pin and xtalout and connect the appropriately valued capacitor from this pin to Vss.  If an external clock is used, this is a 5 V tolerant CMOS input with 50 MHz max input frequency.
xtalout	Y14	—	O	<b>Crystal Output Feedback.</b> If a crystal is used, connect it between this pin and xtalin and connect the appropriately valued capacitor from this pin to Vss. If an external clock is used to drive xtalin, this pin must be left unconnected.
cko	W11	—	O	<b>Buffered Clock Output.</b> If enabled, pclk is output on this pin. 8 mA drive, TTL compatible output. This pin is high impedance if not enabled.
cko_e	V11	—	I	<b>CKO Enable.</b> Enable for buffered clock output. If cko is not used, tie this enable pin low. Active-high, TTL compatible input, 5 V tolerant.
NC	A2, A3, A16, B2, B3, B4, C3, C4, C5, D5, U16, V3, V4, V17, V18, W1, W2, W3, W4, W18, W19, Y1, Y2, Y15, Y17, Y18, Y19, Y20	—	—	<b>No Connection.</b> Reserved.

Table 8. Power Pins

Symbol	Ball	Name/Description
V <sub>DD</sub>	D6, D11, D15, F4, F17, K4, L17, R4, R17, U6, U10, U15	<b>Power.</b> 3.3 V. These pins should be properly decoupled using 0.01 μF or 0.1 μF capacitors.
V <sub>SS</sub>	A1, D4, D8, D13, D17, H4, H17, J9, J10, J11, J12, K9, K10, K11, K12, L9, L10, L11, L12, M9, M10, M11, M12, N4, N17, U4, U8, U13, U17	<b>Ground.</b>
V <sub>DDA</sub>	W14	<b>Clock Oscillator Power.</b> 3.3 V. This pin should be properly decoupled using 0.01 μF or 0.1 μF capacitors.

2 Pin Description (continued)

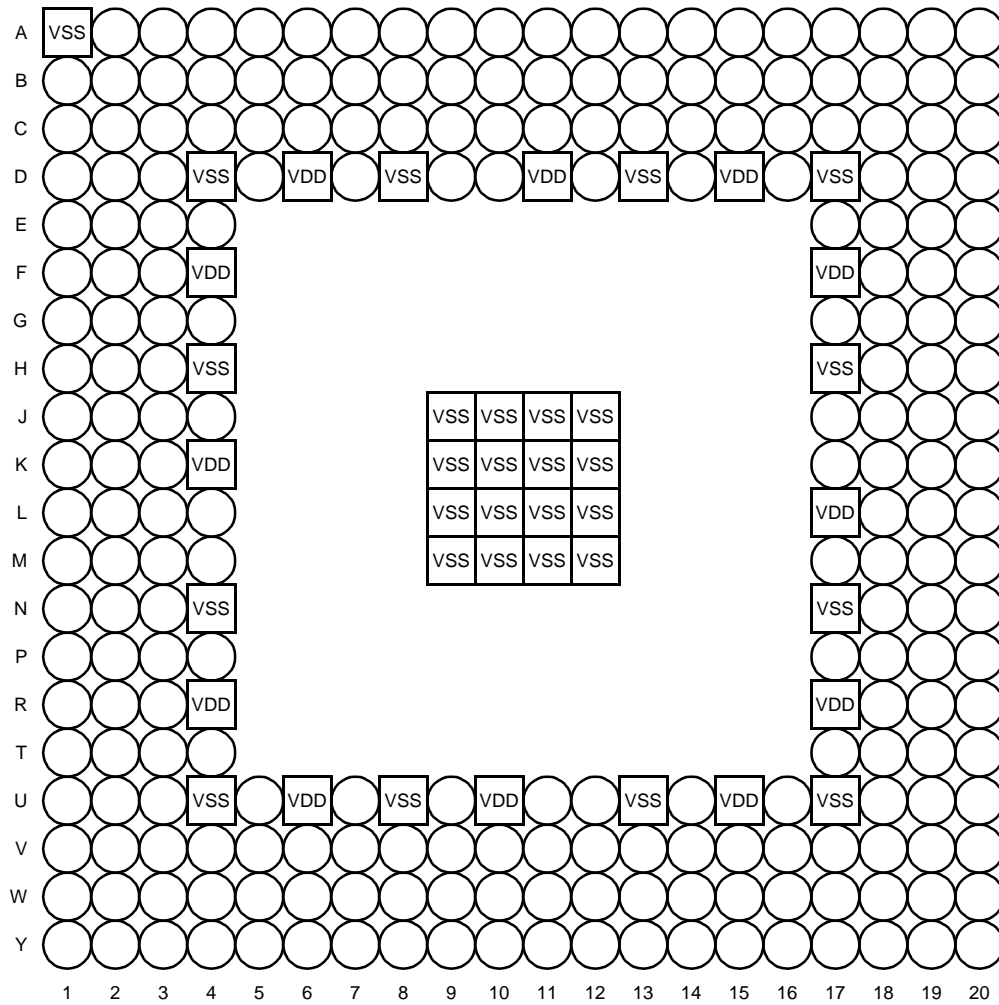

Figure 3. 272-Pin PBGA—Top View

5-8013(f)

### **3 Powerup/Reset Sequence**

One of the following two methods may be used to reset the T8207:

1. Assert the reset\* pin low for at least 5 pclk periods or 100 ns, whichever is longer, and then return it high for a hardware reset. For a powerup reset, the reset\* pin should be held low for at least 5 pclk periods or 100 ns, whichever is longer, after the power supply ramps to its operating voltage and the crystal oscillator is stable.
2. Write both the srst\* and srst\_reg\* bits in the direct configuration/control register (address 28h) to '0,' and leave them at that value for at least 1  $\mu$ s to perform a software reset.

The device is now in the reset state, and the following start-up procedure must be executed to ensure proper operation:

1. After pclk (xtalin) is provided to the T8207, and the device is in the reset state:
  - A. Write the mclk PLL configuration 0 and 1 registers at addresses 2Ah and 2Bh.
  - B. Continue after the PLL has stabilized in 100  $\mu$ s.
2. Set the srst\_reg\* bit (to take the main registers out of reset), and program the cyc\_per\_acc and big\_end bits in the direct configuration/control register (address 28h).
3. Wait 1  $\mu$ s for the circuit to stabilize.

#### **Extended memory accesses may now be performed only to the main register group.**

4. Write the desired values to the main configuration 1 register (address 0100h), the TX UTOPIA clock configuration register (address 010Ch), and the RX UTOPIA clock configuration register (address 010Eh) in the extended memory registers. These bits should not be modified at a later time without returning to the reset state.
5. Program the main configuration 2 register (address 0112h) and the UTOPIA configuration register (address 0114h). These registers should not be modified at a later time without returning to the reset state.
6. Program the cb\_arb\_sel and cb\_usr\_mode bits in the cell bus configuration/status register (address 0130h).
7. Wait one clock period of the slowest clock (cell bus, UTOPIA, or pclk) for the circuit to stabilize.
8. Set the srst\* bit in the direct configuration/control register (address 28h).
9. Wait three clock periods of the slowest clock (cell bus, UTOPIA, or pclk) for the circuit to stabilize.

#### **The T8207 device is now out of reset state.**

10. Initialize the SDRAM per the SDRAM specifications.
11. Enable the SDRAM by setting the sdram\_en bit in the SDRAM control register (address 0400h).
12. Initialize the LUT to benign values (recommended).
13. Initialize the multicast memory to all '0' (recommended).
14. Program the three routing information registers (addresses 0200h through 0204h) and the seven PPD information registers (addresses 0206h through 0212h).

## **4 Hot Insertion**

When a connector with proper pin sequencing is used, the Agere Systems Inc. GTL+ buffers withstand hot insertion into a backplane without corrupting the cell bus or damaging the device. The ground pins on the connector should extend beyond all other pins so that the ground connections are made first. In addition, the power pins on the connector should extend beyond the signal pins so that the power connections are made before the signal but after the ground connections.

During hot insertion, the cell bus is not corrupted because the GTL+ outputs go to a high-impedance state during the powerup reset. Therefore, proper timing should be met in the external powerup reset circuit.

## 5 PLL Configuration

The frequency of the device's main clock (mclk) is derived from the clock at the xtalin input (pclk) and is given by the following equation when the PLL is engaged:

$$f_{mclk} = f_{pclk} \times \frac{(M + 2)}{(2 \times (\text{MOD8}(N + 1) + 1))}$$

**Note: When the PLL is engaged, mclk is the output of the PLL.**

M and N are the pll\_m[4:0] and pll\_n[2:0] counter values in the mclk PLL configuration 1 register (address 2Bh) and must be set so that the voltage-controlled oscillator (VCO) operates in the appropriate range. The maximum value for f<sub>mclk</sub> is 100 MHz. The valid range for M is between 2 and 22 inclusive, and the valid range for N is between 0 and 7 inclusive. When multiple sets of values can achieve the desired result, choose the lowest value of M and the corresponding value for N.

**Note: The output of the PLL must always be at least 50 MHz.**

The loop filter must be set properly for correct operation of the PLL. The proper setting of the loop filter bits, lf[3:0], in the mclk PLL configuration 0 register (address 2Ah) is determined by the chosen value for M. The following table lists the lf[3:0] settings for given values of M. Typical PLL lock-in time is 50 μs.

**Table 9. Loop Filter Register Settings**

M	Mclk PLL Configuration 0 (2Ah) lf[3:0]
22	"0111"
16—21	"0110"
10—15	"0101"
6—9	"0100"
4—5	"0011"
2—3	"0010"

### PLL Configuration Example:

Given a pclk frequency of 50 MHz and a desired mclk frequency of 100 MHz, the proper values of M, N, and lf[3:0] are the following:

$$M = 2$$

$$N = 7$$

$$lf[3:0] = "0010"$$

The bypass PLL (bypb) and PLL enable (pllen) bits are used to select the source of mclk for the T8207. To select the output of the PLL as the clock, both bits must be programmed to '1,' and to select pclk as the clock, both bits must be programmed to '0.'

## 6 Microprocessor Interface

### 6.1 Microprocessor Interface Configuration

The microprocessor interface may be configured for either *Intel* or *Motorola* mode via the *mot\_sel* input. Tie *mot\_sel* high to select *Motorola* mode and low to select *Intel* mode. In addition, the address and data buses may be configured for multiplexed or nonmultiplexed mode using the *mux* input. To select multiplexed mode, tie *mux* high, and to select nonmultiplexed mode, tie *mux* low. In multiplexed mode, *d[7:0]* are used for both the address and the data bus, and the *a[0]* input becomes an address latch enable (*ale*) signal. In nonmultiplexed mode, separate address, *a[7:0]*, and data, *d[7:0]*, buses are used. In both modes, the active-low *sel\** input selects the device for microprocessor read or write accesses. The data leads are 3-stated when the *sel\**, *wr\*\_ds\**, or *rd\*\_wr\** signal is high.

In *Motorola* mode, *rd\*\_rw\** is a read/write enable signal, which indicates the current access is a read when it is high and a write when low. The *wr\*\_ds\** signal is data strobe in *Motorola* mode. The *rdy\_dtack\** output is an active-low data transfer acknowledge signal. The T8207 takes this signal low when the microprocessor access is complete. The *rdy\_dtack\** output returns high when the microprocessor acknowledges the access by taking the *sel\** or *wr\*\_ds\** signal high. The *rdy\_dtack\** output then goes high-impedance.

In *Intel* mode, the *rd\*\_rw\** input is an active-low read enable signal, and *wr\*\_ds\** is an active-low write enable signal. A logic low level on *rd\*\_rw\** indicates to the T8207 that the current access is a read, and a logic low level on *wr\*\_ds\** indicates the access is a write. Finally, the *rdy\_dtack\** output is an active-high ready signal. The T8207 asserts this signal high when a microprocessor access is complete. The *rdy\_dtack\** output then goes high-impedance when the *sel\**, *wr\*\_ds\**, or *rd\*\_wr\** signal goes high.

### 6.2 Microprocessor Interrupts

The *int\_irq\** output is an active-high interrupt in *Intel* mode and an active-low interrupt request in *Motorola* mode. In *Intel* mode, *int\_irq\** is normally low and goes high when an interrupt is generated. In *Motorola* mode, the interrupt request signal is normally high and goes low during an interrupt. Interrupts are generated when an enabled interrupt status bit becomes set. All interrupt status bits in the T8207 have a corresponding interrupt enable bit. When the enable bit is cleared, the corresponding interrupt status bit is not enabled and will not generate an interrupt. Several registers containing interrupt status bits exist in the three separate extended memory register groups (main, UTOPIA, and SDRAM) of the T8207. The interrupt service request register at direct address 29h indicates which register group is generating the interrupt. Only enabled interrupts will cause the *int\_serv\_mainreg*, *int\_serv\_sdramreg*, and *int\_serv\_utopiareg* bits to become set. For the main register group, a special case exists. The *ctrl\_cell\_sent* and the *ctrl\_cell\_av* interrupts (in the main interrupt status 1 register) do not cause the main group indication bit to be set in the interrupt service request register. These interrupts have their own dedicated service request bits to optimize sending and receiving control cells. The *ctrl\_cell\_sent* and *ctrl\_cell\_av* bits may become set whether the corresponding interrupt is enabled or not.

### 6.3 Accessing the CelXpres T8207 via Microprocessor Interface

The CelXpres T8207 has two distinct memory spaces, the direct memory access registers and the extended memory registers. The direct memory access registers are directly addressed 8-bit (byte) registers and are mapped between addresses 00h and FFh. The extended memory registers are indirectly addressed and mapped between addresses 0100h and 3FFFFFFEh. The extended memory contains the SDRAM memory, the translation RAM, internal memories, and the device's configuration, status, and control registers. Extended memory registers are 16 bits wide, and all accesses to the extended memory registers are executed internally as 16 bits. Direct memory access registers are located in Section 14.2, Direct Memory Access Registers, and extended memory registers are located in Section 14.3, Extended Memory Registers.

## **6 Microprocessor Interface** (continued)

### **6.3.1 Accessing the Extended Memory Registers**

Before accessing the extended memory registers, the powerup sequence, as described in Section 3, Powerup/Reset Sequence, must be completed. Accesses to extended memory are word accesses internally; therefore, the least significant bit of the address is always '0.' Only the most significant 25 bits are supplied to the extended memory address registers (addresses 30h—34h). The following procedure outlines the steps needed for extended memory accesses in the T8207 device.

#### **6.3.1.1 Extended Memory Writes**

1. Write ext\_a [25] bit to the extended memory address 4 register (little endian or big endian) (optional).
2. Write ext\_a [24:17] byte to the extended memory address register 3 (little endian or big endian) (optional).
3. Write ext\_a [16:9] byte to the extended memory address register 2 (little endian or big endian) (optional).
4. Write ext\_a [8:6] bits to the extended memory address register 1 (little endian or big endian) (optional).
5. Write ext\_d [15:8] byte to the extended memory data high register (little endian or big endian) (optional).
6. Write ext\_d [7:0] byte to the extended memory data low register (little endian or big endian) (optional).
7. Write ext\_a [5:1] bits; write "01," "10," or "11" to ext\_we[1:0]; and write '1' to ext\_strt\_acc in the extended memory access register (little endian or big endian) (mandatory).
8. Read the extended memory access register (little endian or big endian) to determine that the ext\_strt\_acc bit has been cleared by hardware (mandatory).

#### **6.3.1.2 Extended Memory Reads**

1. Write ext\_a [25] bit to the extended memory address 4 register (little endian or big endian) (optional).
2. Write ext\_a [24:17] byte to the extended memory address register 3 (little endian or big endian) (optional).
3. Write ext\_a [16:9] byte to the extended memory address register 2 (little endian or big endian) (optional).
4. Write ext\_a [8:6] bits to the extended memory address register 1 (little endian or big endian) (optional).
5. Write ext\_a [5:1] bits; write "00" to ext\_we[1:0]; and write '1' to ext\_strt\_acc in the extended memory access register (little endian or big endian) (mandatory).
6. Read the extended memory access register (little endian or big endian) to determine that the ext\_strt\_acc bit has been cleared by hardware (mandatory).
7. Read ext\_d [15:8] byte from the extended memory data high register (little endian or big endian) (optional).
8. Read ext\_d [7:0] byte from the extended memory data low register (little endian or big endian) (optional).

**Note:** Once the ext\_strt\_acc bit is set by software, only the extended memory access register should be accessed until the ext\_strt\_acc bit is cleared by hardware.



## 6 Microprocessor Interface (continued)

### 6.3.2 CelXpres T8207 Access Performance

The times represented in the following table reflect access times for various microprocessor interface reads and writes. For direct access registers, the values represent the time until the rdy\_dtack signal transitions indicating the data transfer portion of the access is complete. For accesses to extended memory, the values represent the time from the completion of a write to register 34h until the ext\_strt\_acc bit is cleared.

The actual times are dependent on the frequency of the pclk and mclk clocks (see Section 5, PLL Configuration). The terms pclkp and mclkp in the table represent the period of pclk and mclk, respectively, in ns.

**Table 10. Access Times**

Description	Min	Typ	Max	Unit
Read/Write to 28h—3Dh	4 x pclkp	5 x pclkp	5 x pclkp + 30	ns
Reads to: 60h—93h, A0h—D7h, E0h—FFh (direct internal memory)	6 x pclkp + 3 x mclkp	8 x pclkp + 9 x mclkp	12 x pclkp + 15 x mclkp	ns
Writes to: 60h—93h, A0h—D7h, E0h—FFh (direct internal memory)	6 x pclkp	8 x pclkp + 4 x mclkp	10 x pclkp + 9 x mclkp	ns
Reads to Extended Memory Internal Structures	6 x pclkp + 6 x mclkp	8 x pclkp + 12 x mclkp	12 x pclkp + 18 x mclkp	ns
Writes to Extended Memory Internal Structures	6 x pclkp	8 x pclkp + 7 x mclkp	10 x pclkp + 12 x mclkp	ns
Read from LUT SRAM	4 x pclkp + 11 x mclkp	—	10 x pclkp + 50 x mclkp	ns
Write to LUT SRAM	4 x pclkp	—	10 x pclkp + 50 x mclkp	ns

## **7 General-Purpose I/O (GPIO)**

The T8207 has eight programmable general-purpose I/O pins called GPIO. These GPIO pins may be independently programmed, via the GPIO\_oe[7:0] bits in the GPIO output enable register (address 39h), to be inputs or outputs. If a GPIO\_oe bit is set to '1,' the corresponding GPIO pin is an output, or if cleared to '0,' the corresponding GPIO pin is an input. Input values are read from the GPIO\_in[7:0] bits in the GPIO input value register (address 3Dh), and output values are written to the GPIO\_out[7:0] bits in the GPIO output value register (address 3Bh). The GPIO[7:0] pins all have internal 50 k $\Omega$  pull-up resistors.

## 8 Look-Up Table

Cells arriving from the UTOPIA bus obtain information from the external static RAM look-up table (LUT), which is divided among VPI, VCI, and OAM/RM records. Each of these records contains specific VPI or VPI/VCI translation and cell bus routing information. The size of the records is programmable to 8 bytes or an extended 16 bytes. The 16-byte mode adds two 32-bit counters to each record. The 16-byte mode is discussed in Section 8.4, Extended Records.

The VPI value in the header, in addition to the PHY port number, of the incoming cell points to a VPI record in the look-up table. This VPI record is examined first. If the VPI record indicates OAM F4 routing, the OAM record, to which the VPI record points, provides the OAM routing and VPI/VCI translation information. If OAM F4 routing is not indicated, information about the type of translation, VPI only or VPI/VCI, is obtained from the original VPI record. For VPI only translation, routing information is obtained from the VPI record, and full or partial VPI translation is performed.

For VPI/VCI translation, the VPI record points to the appropriate VCI record, where VPI/VCI translation and routing information is stored. If the VCI record indicates OAM F5 routing, the OAM record, to which the VCI record points, provides the OAM routing and VPI/VCI translation information. If no OAM F5 routing is indicated, VPI/VCI translation and cell routing is performed using the information in the VCI record.

### 8.1 Look-Up Table RAM

The number of memory devices (up to two) used for the look-up table and the size of the external SRAM are programmable. The `tram_qnty_sel` bit in the main configuration 1 register (address 0100h) specifies whether one or two RAM chips are used. If two memory devices are used, separate chip select signals are generated. These chip selects are created from the decoded RAM addresses. The `tram_size` configuration bits, also in the main configuration 1 register, are used to select memory sizes of 32 Kbytes, 64 Kbytes, 128 Kbytes, or 256 Kbytes. Therefore, the maximum look-up table size of 512 Kbytes is realized when two RAM chips of 256 Kbytes each are used.

## 8 Look-Up Table (continued)

### 8.2 Organization

Organization is discussed in terms of 8-byte records. Differences in organization for 8-byte records and 16-byte records will be discussed in Section 8.4, Extended Records. The look-up table may be configured to support up to 16 ports when multi-PHY mode is used, effectively creating a separate look-up table for each port.

**For 32 ports, each even and odd pair of ports share a look-up table space.**

All VPI, VCI, and OAM/RM records may be either 8 bytes or 16 bytes in length. (See Section 8.4, Extended Records for information on 16-byte records.) Figure 4 shows the translation RAM memory map for 8-byte records when the device is configured for 16 or less PHY ports. When greater than 16 PHY ports are used, the look-up table is shared between even and odd ports. Figure 5 shows this translation RAM memory map. OAM/RM translation records are located at the bottom of the memory space with 64 OAM/RM records used by each port. If the device is configured to support 16 to 32 ports, the first 1024 records will be used for OAM and RM translation records. This translates to 8 Kbytes of memory for 8-byte records. The remaining memory is then used for VPI and VCI records. For 8-byte records, when 16 ports or less are used, the base addresses of the OAM records are calculated from the following equation:

$$OBA = PN \times 8 \times 64$$

In this equation, OBA is the OAM base address, PN is the port number, 8 is the number of bytes per record, and 64 is the number of records per port. For example, the OAM/RM translation records for port 2 will have a base address of 1024 or 400h.

For 8-byte records, when greater than 16 ports are used, the base addresses of the OAM records are calculated from the following equation:

$$OBA = \text{INT}(PN/2) \times 8 \times 64$$

In this equation, OBA is the OAM base address, PN is the port number; 8 is the number of bytes per record, and 64 is the number of records per port. The INT function specifies that the term within the parentheses is an integer, i.e., the fractional part is discarded. For example, the OAM/RM translation records for port 5 will have a base address of 1024 or 400h.

**Note:** If the device is configured to use less than 16 ports, the OAM/RM translation record memory space will be allocated enough memory to handle ports 0 through the maximum port number used. For example, if the device is configured to use ports 0, 2, 4, and 6 (see Section 9, UTOPIA Interface), the OAM/RM translation record memory space will use 448 records (for ports 0 through 6). OAM/RM translation record memory space for ports 1, 3, and 5 will be skipped even though the ports are not used.

**Note:** If the device is configured in PHY mode (see Section 9, UTOPIA Interface), the device supports only a single PHY and the translation RAM memory will be addressed as port 0.

Separate VPI record base addresses may be set up for each port in multi-PHY mode (for up to 16 ports), and the number of incoming VPI bits used as a pointer into the look-up table may be programmed. (See Section 14.3, Extended Memory Registers, Table 103.) For 8-byte records, when 16 ports or less are used, the total memory used by the VPI records is calculated using the following equation:

$$MS = NP \times 2^{NB} \times 8$$

In this equation, MS is the memory size used for VPI records, NP is the number of ports used, 8 is the number of bytes per record, and NB is the number of incoming VPI bits used to address the look-up table.

For 8-byte records, when greater than 16 ports are used, the total memory used by the VPI records is calculated using the following equation:

$$MS = \text{INT}(NP/2) \times 2^{NB} \times 8$$

In this equation, MS is the memory size used for VPI records, NP is the number of ports used (greater than 16), 8 is the number of bytes per record, and NB is the number of incoming VPI bits used to address the look-up table. The INT function specifies that the term within the parentheses is an integer, i.e., the fractional part is discarded.

This calculated memory space must be reserved for VPI records.

## 8 Look-Up Table (continued)

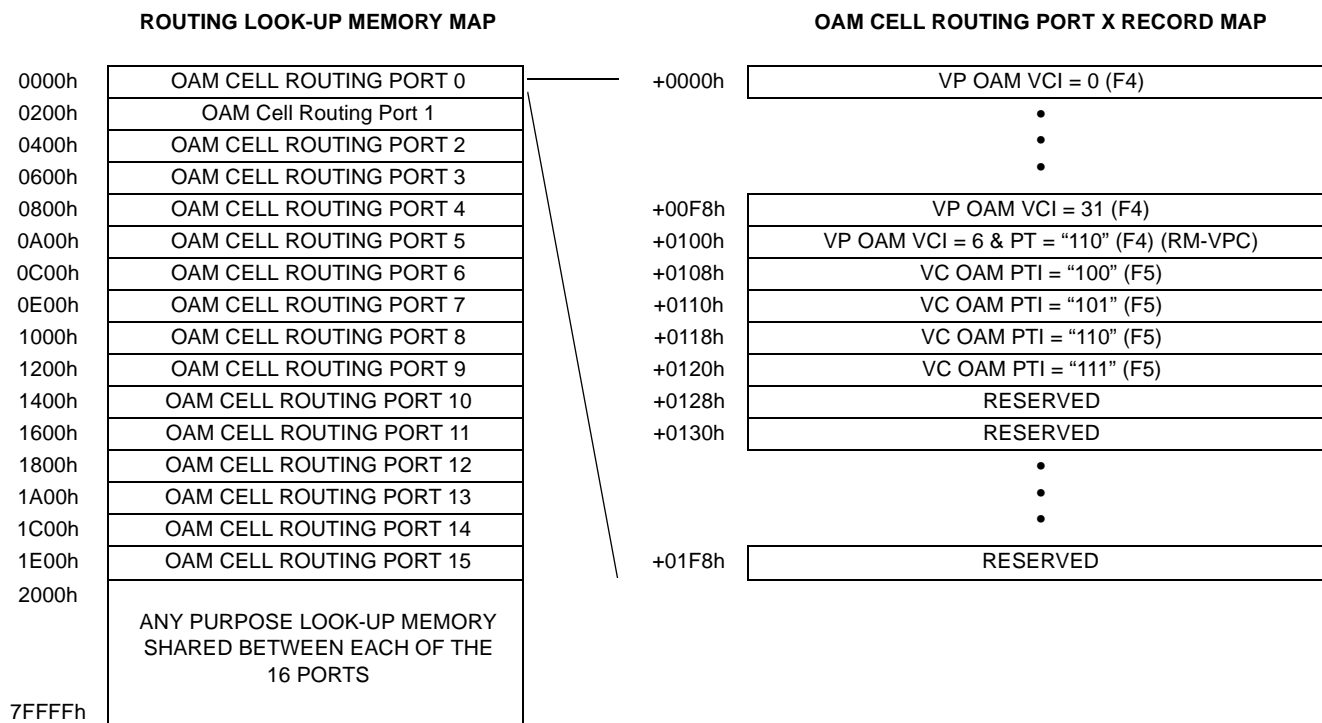
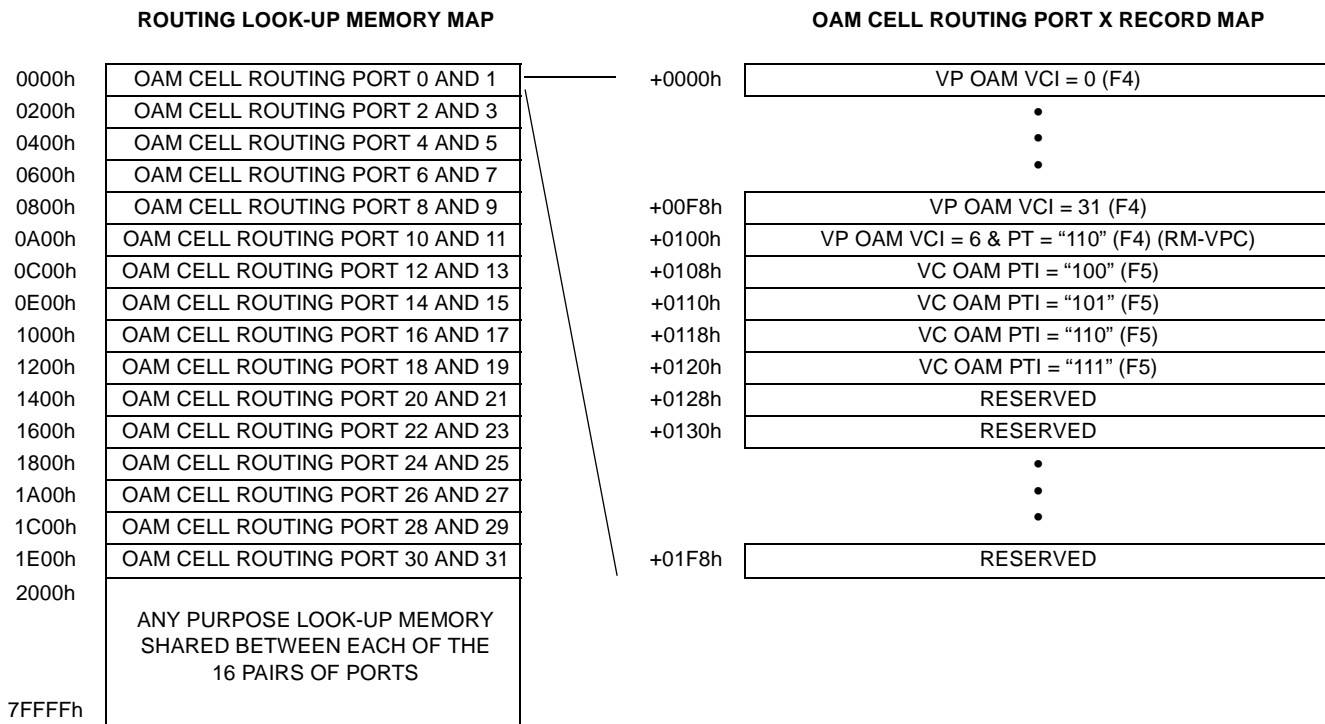

Figure 4. Translation RAM Memory Map—8-Byte Records, for Up to 16 Ports

The four translation record types (VCI, OAM/RM, VPI only, and VPI for VPI/VCI) for 8-byte records are illustrated in Figure 6. There are two types of VPI translation records: one for VPI translation only and one for VPI/VCI translation. The VPI only translation record differs from other records in that it has the SH and SL bits which are used to indicate full or partial VPI translation. (See Table 12, the VPI Value Truth Table.) The other VPI record is used when VPI/VCI translation occurs. It has the VCI offset bits and max VCI value bits which are used to point to the VCI record where translation and routing information reside. The maximum VCI offset is 19 bits in length; therefore, only bits 3 through 18 are stored in the VPI record.

To address the appropriate VCI translation record, the VCI from the cell's header is multiplied by 8 and added to bits 3 through 18 of the VCI offset which is obtained from the VPI record. This sum is the final offset into the look-up table. This final offset should then be added to the translation RAM memory beginning address 100000h (Table 125) to obtain the final address. The max VCI value indicates the maximum number of VCI translation records in the table. Therefore, if the VCI from the cell's header is greater than the max VCI value, the cell's VCI is out of range and is counted as a misrouted cell. Note that VPI records from different ports may reference the same VCI translation record. Other control bits in these records are described following Figure 6.

**8 Look-Up Table** (continued)



**Figure 5. Translation RAM Memory Map—8-Byte Records, for Greater than 16 Ports**

## 8 Look-Up Table (continued)

VPI ONLY TRANSLATION RECORD																
	b15	b14	b13	b12	b11	b10	b9	b8	b7	b6	b5	b4	b3	b2	b1	b0
+0	A	P	E	I	VPI[11:0]											
+2	SH	SL	RESERVED													
+4	CELL BUS ROUTING HEADER[15:0]															
+6	TANDEM ROUTING HEADER[15:0]															

VPI for VPI/VCI Translation Record																
	b15	b14	b13	b12	b11	b10	b9	b8	b7	b6	b5	b4	b3	b2	b1	b0
+0	A	P	E	I	RESERVED											
+2	BITS 3 THROUGH 18 OF VCI OFFSET[15:0]															
+4	MAX VCI VALUE[15:0]															
+6	RESERVED															

VCI TRANSLATION RECORD																
	b15	b14	b13	b12	b11	b10	b9	b8	b7	b6	b5	b4	b3	b2	b1	b0
+0	A	—	E	I	VPI[11:0]											
+2	VCI[15:0]															
+4	CELL BUS ROUTING HEADER[15:0]															
+6	TANDEM ROUTING HEADER[15:0]															

OAM/RM TRANSLATION RECORD																
	b15	b14	b13	b12	b11	b10	b9	b8	b7	b6	b5	b4	b3	b2	b1	b0
+0	A	C1	C0	I	VPI[11:0]											
+2	VCI[15:0]															
+4	CELL BUS ROUTING HEADER[15:0]															
+6	TANDEM ROUTING HEADER[15:0]															

Figure 6. Translation Record Types—8-Byte Records

The routing control bits for VPI, VCI, and OAM/RM records are described below:

- Active (A). This bit is one when the VPI or VCI is considered active. See the truth table (Table 11) below. This bit is used in all types of records.
- Ignore (I). When this bit is one, the VPI or VCI is ignored. See the truth table (Table 11) below. This bit is used in all types of records.

Table 11. Active and Ignore Truth Table

A	I	Action
0	0	The cell is discarded, considered misrouted, and counted as a received cell.
0	1	The cell is discarded, is not flagged as misrouted, and is not counted as a received cell.
1	0	The cell is valid and is counted as a received cell.
1	1	The cell is discarded, is not flagged as misrouted, and is not counted as a received cell.

**8 Look-Up Table** (continued)

- **Enable OAM/RM Routing (E).** When this bit is '1' in the VPI record and the VCI is less than 32, the routing and translation information is obtained from the appropriate OAM/RM F4 record. If this bit is '1' in the VCI record and the most significant bit of the PTI in the cell header is '1,' the routing and translation information is obtained from the appropriate OAM/RM F5 record. This bit is used only in VPI and VCI records.
- **VPI Translation (P).** When this bit is '1,' translation is on the VPI only. When this bit is '0,' VPI/VCI translation is performed. This bit is used only in VPI records.
- **VPI Value High (SH).** When this bit is '1,' bits 8 through 11 of the incoming VPI are replaced with the corresponding bits in the VPI record. See the truth table (Table 12) below. This bit is used in VPI only translation records.
- **VPI Value Low (SL).** When this bit is '1,' bits 0 through 7 of the incoming VPI are replaced with the corresponding bits in the VPI record. See the truth table (Table 12) below. This bit is used in VPI only translation records.

**Table 12. VPI Value Truth Table**

SH	SL	Action
0	0	No VPI translation is performed.
0	1	VPI translation is performed only on bits 0—7 of the incoming VPI.
1	0	VPI translation is performed only on bits 8—11 of the incoming VPI.
1	1	Complete VPI translation is performed.

- **OAM Routing Control (C1, C0).** These 2 bits determine if the cell is routed as OAM/RM and if VPI/VCI translation is performed. See the truth table (Table 13) below. These bits are used only in OAM/RM records.

**Table 13. OAM Routing Control Truth Table**

C1	C0	Action
0	0	Both incoming VPI and VCI are substituted with the VPI <sup>1</sup> and VCI, respectively, in the OAM/RM record, and the cell is routed according to the cell bus and tandem routing headers in the OAM/RM record.
0	1	The cell is not routed as OAM/RM. If the record is OAM/RM F5, the cell is translated and routed according to the cell bus and tandem routing headers in the original VCI record. If the record is OAM/RM F4, the cell is translated and routed according to the cell bus and tandem routing headers in the original VPI record.
1	0	The incoming VPI and VCI will be preserved, and the cell is routed according to the cell bus and tandem routing headers in the OAM/RM record.
1	1	Reserved.

1. The most significant 4 bits of the VPI will only be substituted if the global rplc\_gfc bit in the direct configuration/control register (address 28h) is set in UNI mode or if the port is configured in NNI mode.



## 8 Look-Up Table (continued)

### 8.3 Look-Up Procedure

Look-up procedure is discussed in terms of 8-byte records. Differences in look-up procedures for 8-byte records and 16-byte records will be discussed in Section 8.4, Extended Records. When a cell is received, the set lutX\_vpi\_mask bits in the LUT X configuration structure (Table 103) indicate which incoming VPI bits are used to address the VPI record in the look-up table. The selected incoming VPI bits are concatenated and multiplied by eight (for 8-byte records) to create an offset into the table. The sum of this offset and the VPI base address, found in the LUT X configuration structure, creates the actual look-up table address for the VPI record associated with the cell. Note that only bits 3 through 18 of the VPI base address are stored in the LUT X configuration structure. If the lutX\_vpi\_chk bit is set, all unused VPI bits in the cell header must be '0,' or the cell will be considered out of range. If the port is configured as UNI, the upper four VPI bits (GFC field) will be ignored in the verification. When the cell is out of range, it is discarded and not counted as a received cell.

The validity of the accessed VPI record is determined by checking its active (A) and ignore (I) bits. If the cell is valid, the enable OAM/RM routing (E) bit is consulted to determine if F4 type OAM cell treatment should occur. (See the definition for these bits in Section 8.2, Organization.)

When the E bit is set and the incoming VCI is less than 32, the OAM record associated with the cell is read. To calculate the translation record address for the OAM/RM cell, the incoming VCI is multiplied by eight (for 8-byte records), and the resulting product is added to the port's OAM base address. (See Section 8.2, Organization.) A special case exists when the incoming VCI is six and the PTI in the cell header is "110." For this case, the OAM translation record address is the sum of the port's OAM base address and 100h.

Next, the validity of the F4 OAM record is determined by checking its A and I bits. If it is valid, the cell is routed as described by the OAM routing control (C1, C0) bits. (See the definition for these bits in Section 8.2, Organization.)

If the E bit in the VPI record is not one or if the C1 and C0 bits in the OAM record are zero and one, respectively, the cell does not receive OAM routing. If the cell is not routed OAM, the virtual path routing bit (P bit) in the original VPI is checked to determine if the cell receives VPI only or VPI/VCI routing. If the P bit indicates VPI only routing, the cell's VPI is replaced as indicated by the switch VPI high and low (SH, SL) bits in the VPI only translation record. (See the definition for these bits in Section 8.2, Organization.) The cell bus routing header and tandem routing header are then added to the cell, and the cell is transmitted on the cell bus.

If the P bit indicates VPI/VCI routing, the VCI translation record is accessed using the VCI offset and max VCI value bits in the VPI for VPI/VCI translation record. (The VCI offset and max VCI value bits are described in Section 8.2, Organization.) Again, the validity of the VCI translation record is determined by checking its A and I bits. Next, if the cell is valid, the E bit in the VCI record and the most significant bit of the PTI value in the cell header are examined to determine if F5 type OAM cell treatment should occur. The value of the incoming cell's PTI and port number determines the address in the OAM/RM record space. The following table outlines the look-up table offsets used for 8-byte records. The OAM translation record address is the sum of this offset and the port's OAM base address.

**Table 14. F5 Translation Record Addresses Table—8-Byte Records**

PTI	OAM Translation Offset
"100"	Port's OAM base address plus 108h
"101"	Port's OAM base address plus 110h
"110"	Port's OAM base address plus 118h
"111"	Port's OAM base address plus 120h

## **8 Look-Up Table** (continued)

Next, the validity of the F5 OAM record is determined by checking its A and I bits. If it is valid, the cell is routed as described by the OAM routing control (C1, C0) bits. (See the definition for these bits in Section 8.2, Organization.)

If the E bit in the VCI record is not one or if the C1 and C0 bits in the OAM record are zero and one, respectively, the cell does not receive OAM routing. If the cell is not routed as an OAM cell, information in the VCI translation record is used to route the cell. The cell's VPI and VCI are replaced with the VPI and VCI, respectively, in the VCI record. The most significant 4 bits of the VPI will only be substituted if the global `rplc_gfc` bit in the direct configuration/control register (address 28h) is set or if the port is configured in NNI mode. The cell bus routing header and tandem routing header are then added to the cell, and the cell is transmitted on the cell bus.

**Note: Unused OAM cell routing records in the LUT memory space can be used for other purposes.**

## 8 Look-Up Table (continued)

This look-up procedure is outlined in the flow diagram below.

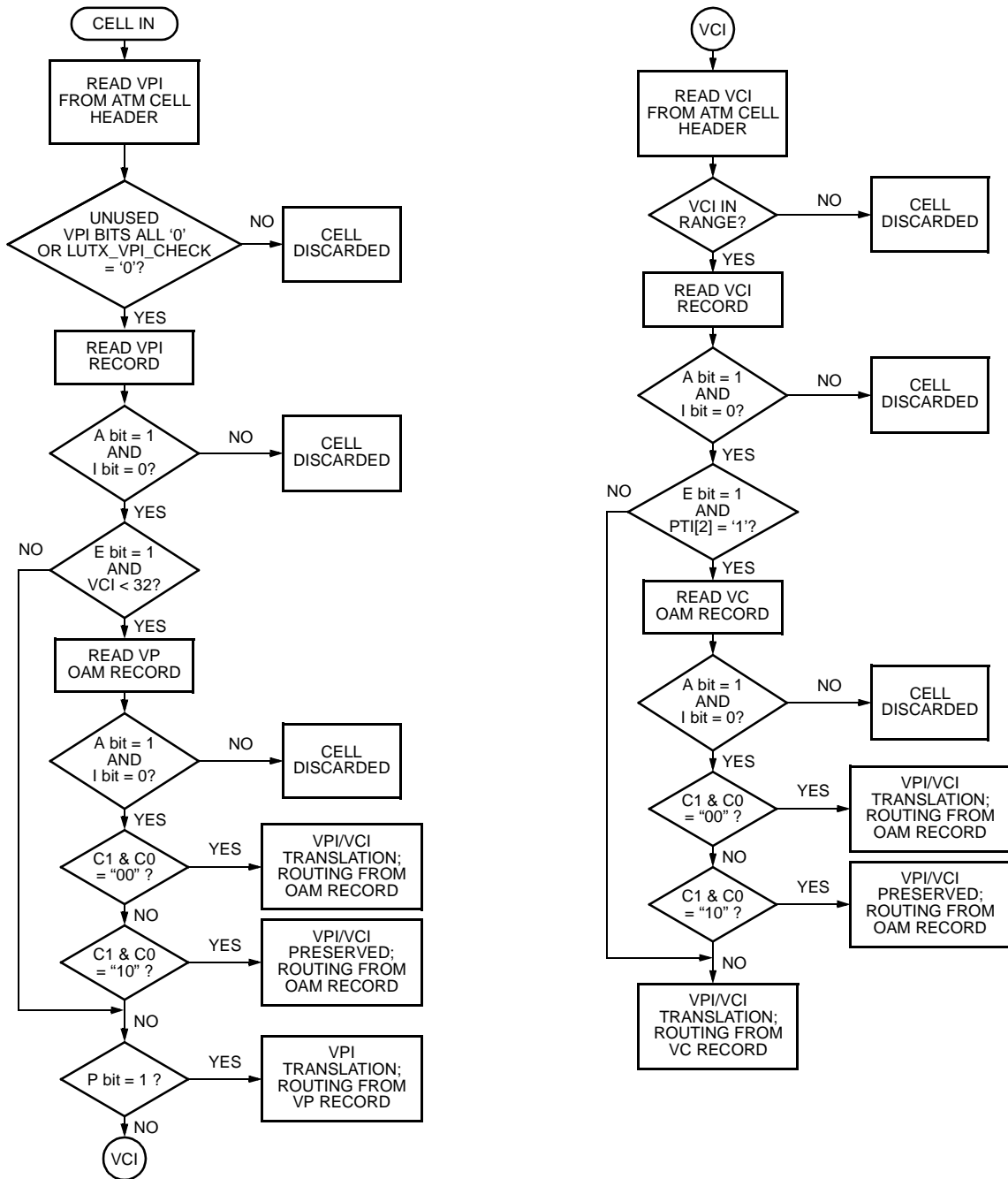

Figure 7. Translation RAM Flow Diagram

5-7781F and 5-7782F

## **8 Look-Up Table** (continued)

### **8.4 Extended Records**

The length of the translation records may be extended to 16 bytes to support two cell counts for each translation record. The `lut_rec_form` bits in the extended LUT configuration register (address 011Eh) are used to select this extended mode. In extended (16-byte) mode, two 32-bit counters are appended to the 8-byte records.

The first counter in the translation record, total cell count, keeps a total count of all incoming cells received from the UTOPIA bus and ultimately routed from this record. See the definition of the A and I bits in Section 8.2, Organization.

The second counter, special cell count, is a subset of the total cell count counter. This counter counts only cells whose PTI and CLP values in the cell header match the values specified in the extended LUT control register (address 0120h). For example, this counter may be used to track specific F5 type OAM/RM cells and cells indicating forward congestion (EFCl = 1) or lower priority (CLP = 1).

## 8 Look-Up Table (continued)

The four translation record types for extended mode are illustrated in Figure 8 below.

EXTENDED VPI ONLY TRANSLATION RECORD																
	b15	b14	b13	b12	b11	b10	b9	b8	b7	b6	b5	b4	b3	b2	b1	b0
+0	A	P	E	I	VPI[11:0]											
+2	SH	SL	RESERVED													
+4	CELL BUS ROUTING HEADER[15:0]															
+6	TANDEM ROUTING HEADER[15:0]															
+8	TOTAL CELL COUNT[31:16]															
+A	TOTAL CELL COUNT[15:0]															
+C	SPECIAL CELL COUNT[31:16]															
+E	SPECIAL CELL COUNT[15:0]															

EXTENDED VPI FOR VPI/VCI TRANSLATION RECORD																
	b15	b14	b13	b12	b11	b10	b9	b8	b7	b6	b5	b4	b3	b2	b1	b0
+0	A	P	E	I	RESERVED											
+2	BITS 3 THROUGH 18 OF VCI OFFSET[15:0]															
+4	MAX VCI VALUE[15:0]															
+6	RESERVED															
+8	RESERVED															
+A	RESERVED															
+C	RESERVED															
+E	RESERVED															

EXTENDED VCI TRANSLATION RECORD																
	b15	b14	b13	b12	b11	b10	b9	b8	b7	b6	b5	b4	b3	b2	b1	b0
+0	A	—	E	I	VPI[11:0]											
+2	VCI[15:0]															
+4	CELL BUS ROUTING HEADER[15:0]															
+6	TANDEM ROUTING HEADER[15:0]															
+8	TOTAL CELL COUNT[31:16]															
+A	TOTAL CELL COUNT[15:0]															
+C	SPECIAL CELL COUNT[31:16]															
+E	SPECIAL CELL COUNT[15:0]															

  

EXTENDED OAM/RM TRANSLATION RECORD																
	b15	b14	b13	b12	b11	b10	b9	b8	b7	b6	b5	b4	b3	b2	b1	b0
+0	A	C1	C0	I	VPI[11:0]											
+2	VCI[15:0]															
+4	CELL BUS ROUTING HEADER[15:0]															
+6	TANDEM ROUTING HEADER[15:0]															
+8	TOTAL CELL COUNT[31:16]															
+A	TOTAL CELL COUNT[15:0]															
+C	SPECIAL CELL COUNT[31:16]															
+E	SPECIAL CELL COUNT[15:0]															

Figure 8. Translation Record Types—Extended Mode

**8 Look-Up Table** (continued)

Because the translation records are larger in extended mode, the look-up table memory map changes, the translation record address calculations change, and the memory size calculations change. Figure 9 shows the new translation RAM memory map for 16-byte records when the device is configured for 16 or less PHY ports. When greater than 16 PHY ports are used, the look-up table is shared between even and odd ports. Figure 10 shows this translation RAM memory map.

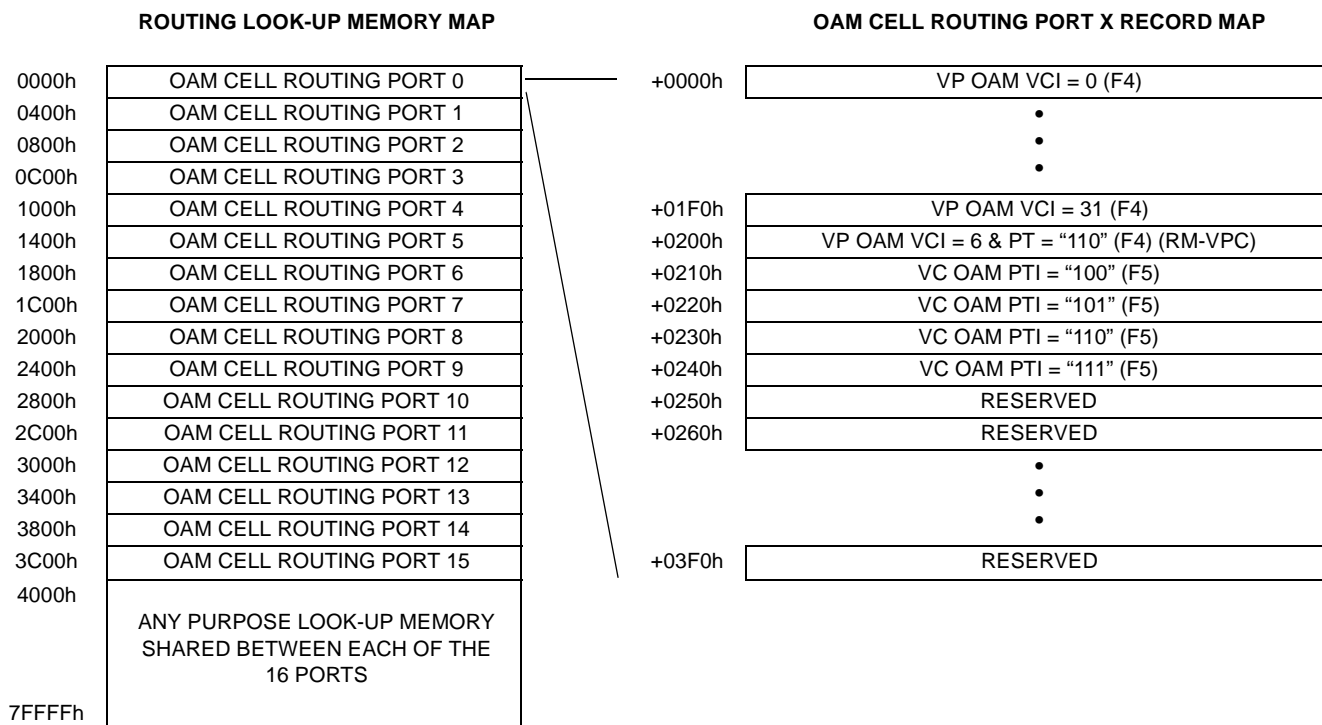

**Figure 9. Translation RAM Memory Map—Extended Mode, for Up to 16 Ports**

8 Look-Up Table (continued)

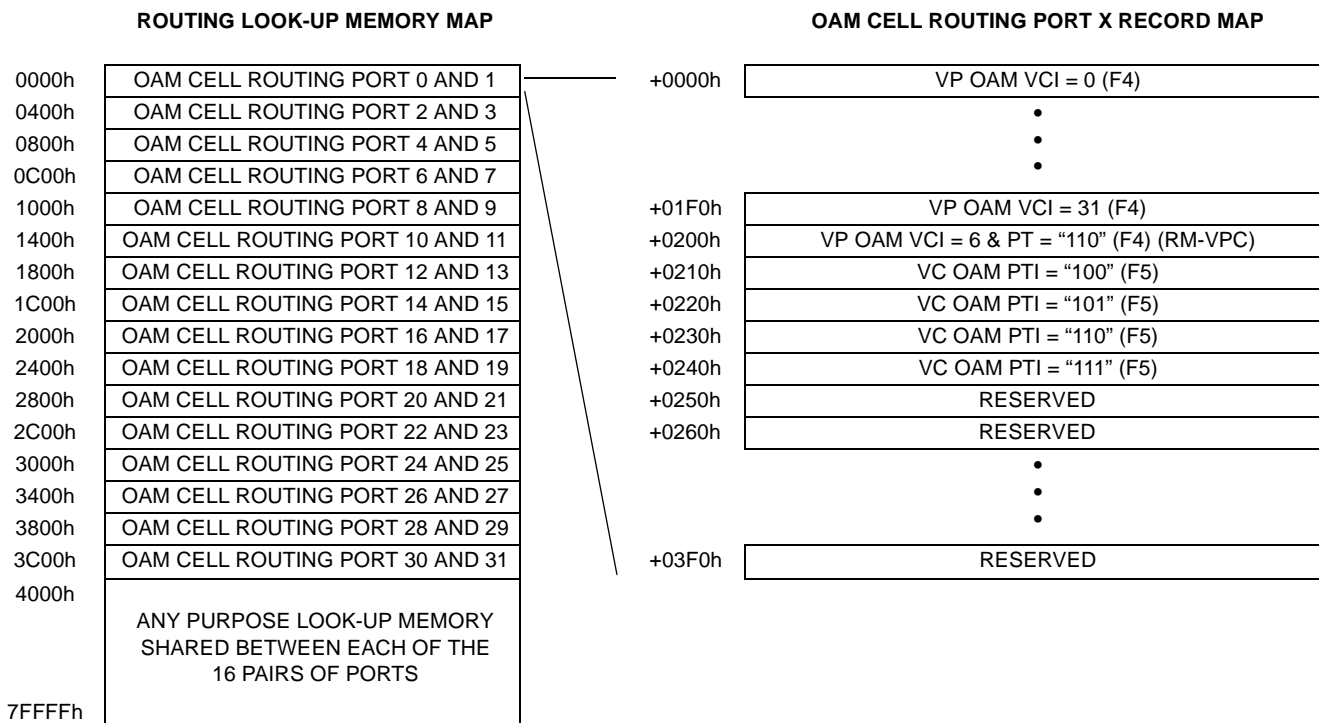

Figure 10. Translation RAM Memory Map—Extended Mode, for Greater than 16 Ports

The OAM/RM translation records at the bottom of the memory map now use 16 Kbytes of memory when the device is configured to support 16 to 32 MPHY ports, and the base addresses for the OAM records are now calculated using the following equation for 16 or less ports:

$$OBA = PN \times 16 \times 64$$

In this equation, OBA is the OAM base address, PN is the port number (for up to 16 ports), 16 is the number of bytes per record, and 64 is the number of records per port.

For 16-byte records, when greater than 16 ports are used, the base addresses of the OAM records are calculated from the following equation:

$$OBA = INT(PN/2) \times 16 \times 64$$

In this equation, OBA is the OAM base address, PN is the port number (for greater than 16 ports), 16 is the number of bytes per record, and 64 is the number of records per port. The INT function specifies that the term within the parentheses is an integer, i.e., the fractional part is discarded.

## 8 Look-Up Table (continued)

To calculate the 16-byte translation record address for the F4 type OAM cell, the incoming VCI is multiplied by 16, and the resulting product is added to the port's OAM base address. For the special case when the incoming VCI is six and the PTI in the cell header is "110," the OAM translation record address is the sum of the port's OAM base address and 200h.

The 16-byte OAM type F5 translation record offset is determined from the incoming cell's PTI using the following table. The OAM translation record address is the sum of this offset and the port's OAM base address.

**Table 15. F5 Translation Record Addresses Table—Extended Mode**

PTI	OAM Translation Offset
"100"	Port's OAM base address plus 210h
"101"	Port's OAM base address plus 220h
"110"	Port's OAM base address plus 230h
"111"	Port's OAM base address plus 240h

In extended mode, the memory space used by the VPI records also changes. The total memory now used by the VPI records is calculated using the following equation for 16 or less ports:

$$MS = NP \times 2^{NB} \times 16$$

In this equation, MS is the memory size used for VPI records, NP is the number of ports used, 16 is the number of bytes per record, and NB is the number of incoming VPI bits used to address the look-up table.

For 16-byte records, when greater than 16 ports are used, the total memory used by the VPI records is calculated using the following equation:

$$MS = \text{INT}(NP/2) \times 2^{NB} \times 16$$

In this equation, MS is the memory size used for VPI records, NP is the number of ports used (for greater than 16 ports), 8 is the number of bytes per record, and NB is the number of incoming VPI bits used to address the look-up table. The INT function specifies that the term within the parentheses is an integer, i.e., the fractional part is discarded.

To address the 16-byte VPI translation record, the selected incoming VPI bits (see Section 8.3, Look-Up Procedure) are concatenated and multiplied by 16 to create an offset into the look-up table. The sum of this offset and the VPI base address creates the actual VPI translation record address associated with the incoming cell. Note that only bits 3 through 18 of the VPI base address are stored in the LUT X configuration structure.

To address the 16-byte VCI translation record, the VCI from the cell's header is multiplied by 16 and added to bits 3 through 18 of the VCI offset which is obtained from the VPI record. This sum is the final offset into the look-up table. This final offset should then be added to the translation RAM memory beginning address 100000h (Table 125) to obtain the final address.



## 8 Look-Up Table (continued)

### 8.5 Diagnostics

The T8207 also includes diagnostics to track misrouted cells. A cell is considered misrouted if its A and I bits are "00," if its VCI is out of range, or if the lutX\_vpi\_chk bit is '1' and the unused VPI bits in the incoming cell header are not all zero (see Section 8.3, Look-Up Procedure). When a misrouted cell is detected, the misrouted cell header high and low registers (addresses 0146h and 0148h) may be updated. If enabled, the mis\_cell interrupt, the vci\_or interrupt, or the vpi\_or interrupt will be generated as appropriate (see Table 79 in Section 14.3, Extended Memory Registers).

The misrouted cell header high and low registers contain the first four header bytes of selected misrouted cells. Only a misrouted cell from a port whose mis\_cell\_lut\_sel bit is set will update these registers, and this misrouted cell will update the registers only if it is the first received after the mis\_cell\_clr bit is set. The lst\_mis\_cell\_lut bits indicate the port from which the header bytes in the misrouted cell header high and low registers were received. The mis\_cell\_lut\_sel bits are located in the misrouted LUT 1 register (address 0142h). The mis\_cell\_clr, mis\_cell\_latch, and lst\_mis\_cell\_lut bits are located in the misrouted LUT 2 register (address 0144h). (See Tables 70 and 71 in Section 14.3, Extended Memory Registers, for a complete description of the above bits.)

### 8.6 Setup

When configuring the lut\_en bits in the LUT X configuration/status register (addresses 0320h through 033Eh), care must be taken to ensure that the enabled ports' LUTs correspond to the ports chosen in UTOPIA mode. (See Section 9.6, UTOPIA Pin Modes.) If a LUT is not enabled, corresponding bits in the LUT X configuration structure (Section 14.3.2.3, RX UTOPIA Monitoring, Table 103) will be ignored. Also, when the device is configured for UTOPIA PHY mode (see Section 9, UTOPIA Interface), only port 0 entries in the external RAM look-up table are used; therefore, the look-up table should be set up accordingly.

## **9 UTOPIA Interface**

The *CelXpres* T8207 supports the ATM Forum's UTOPIA level 1 and level 2 specifications for cell-level handshake and MPHY operation with rates up to 353 Mbits/s. The device may be configured as an ATM layer or as a PHY layer by programming the *phyen\** bit in the main configuration 1 register (address 0100h).

As an ATM layer, the device may interface with a single PHY layer or multiple PHY layers (up to 32). Also as an ATM layer, it may be configured for shared UTOPIA mode if 16 or less PHYs are used. (Note that if shared UTOPIA mode is not used, the *slave\_en* bit in the main configuration/control register (address 0110h) must be cleared at device setup.)

In PHY mode, the T8207 functions as a single PHY device on the UTOPIA bus or as one of 31 PHY devices on the UTOPIA level two bus.

In addition to the required UTOPIA signals, the T8207 supports an additional three transmit and three receive enable (*u\_txenb\*[3:1]* and *u\_rxenb\*[3:1]*) signals, an additional three transmit and three receive cell available (*u\_txclav[3:1]* and *u\_rxclav[3:1]*) signals, a transmit parity (*u\_txprty*) signal, and a receive parity (*u\_rxprty*) signal.

**The T8207 UTOPIA signal names begin with *u\_tx*, for UTOPIA transmit, or *u\_rx*, for UTOPIA receive. References to transmit or receive are made relative to the UTOPIA data flow for the ATM layer UTOPIA interface. Therefore, signals starting with *u\_rx*, such as *u\_rxenb\*[3:0]* and *u\_rxdata[7:0]*, are receive UTOPIA signals for devices in ATM mode but are transmit UTOPIA signals for devices in PHY mode. Furthermore, signals such as *u\_txclav[3:0]* and *u\_txaddr[4:0]* are transmit UTOPIA signals for devices in ATM mode but are receive UTOPIA signals for devices in PHY mode. The above ATM to PHY terminology will be used throughout this UTOPIA Interface section.**

## 9 UTOPIA Interface (continued)

### 9.1 Incoming UTOPIA Cell Interface

#### 9.1.1 Incoming PHY Mode (Cells Received by T8207)

In PHY mode, only one enable ( $u\_rxenb^*[0]$ ) signal and one cell available ( $u\_rxclav[0]$ ) signal are used. The  $u\_rxenb^*[0]$  signal is an input connected to the ATM layer's TxEnb\* signal, and the  $u\_rxclav[0]$  signal is an output connected to the ATM layer's TxClav signal. As a PHY device, the T8207 uses only the LUT 0 configuration/status register (address 0320h) and LUT 0 configuration 1 registers (addresses 0704h—0706h). For UTOPIA level 2 functionality, the PHY address is programmed in the  $addr\_match$  bits of the UTOPIA configuration register (address 0114h), and the  $addr\_clav\_en$  bits of the main configuration 2 register (address 0112h) can be programmed to any value mentioned in the register **except** "000." As specified in the UTOPIA level 2 specification, during the polling process, the T8207 drives the  $u\_rxclav[0]$  signal during the clock cycle following the cycle in which its address appears on the  $u\_rxaddr$  pins. The  $u\_rxclav[0]$  pin goes high impedance when not selected to support MPHY operation. In UTOPIA level 1, the above level 2 bits are not meaningful; therefore, the  $addr\_clav\_en$  bits must be programmed to "000," the  $u\_rxaddr$  pins must be grounded, and the  $addr\_match$  bits cleared.

When the T8207 device is in PHY mode, if bit 5 ( $dont\_inhibit\_rxphy\_clav$ ) of register 0112h is cleared to '0,' the  $rx\_clav$  signal is deasserted if the RX UTOPIA FIFO is considered full. If this bit is set to '1,' the T8207 keeps the  $rx\_clav$  signal always asserted high indicating the capability to accept cells even if the RX UTOPIA FIFO could overrun, or is actually overrun.

#### 9.1.2 Incoming ATM Mode (Cells Received by T8207)

In ATM mode, the T8207 may connect to PHY devices that either meet level 1 or level 2 UTOPIA specifications. If the connection is to devices that meet only UTOPIA level 1 specifications, the T8207 may access up to four of these PHY devices using the four enable ( $u\_rxenb^*[3:0]$ ) and cell available ( $u\_rxclav[3:0]$ ) signals. Connection to more than one PHY device is possible only if the PHY's data, start of cell, and parity outputs go high impedance when the device is not enabled. Polling of the cell available signals usually occurs while the current cell is received.

If the T8207 connects to PHY devices meeting level 2 UTOPIA specifications, one RxCLAV/RxENB pair supports up to 16 PHY ports. For 32 PHY ports, two RxCLAV/RxENB pairs support two groups of 16 PHY ports for a total of 32 PHY ports. In ATM MPHY mode, the  $u\_rxdata[7:0]$ ,  $u\_rxaddr[4:0]$ ,  $u\_rxsoc$ , and  $u\_rxprty$  signals are connected to each PHY port. In addition, the T8207 generates the address ( $u\_rxaddr[4:0]$ ) signals, permitting selection and arbitration among the MPHY ports. The number of address lines used in the connection may vary from one to four, giving a maximum address value of 15. (All five address lines must be connected to provide for the NULL address.) Refer to Section 9.6, UTOPIA Pin Modes, for more information about the possible combinations of address, cell available, and enable signals. The UTOPIA specification for operation with one TxClav and one RxClav is used when the T8207 connects to multiple level 2 PHY devices.

Whether the T8207 is connected to several level 1 or level 2 PHY devices, a round-robin algorithm is implemented that ensures that all PHY devices are serviced (accessed) in a timely manner. In addition, the number of clock cycles wasted for bus arbitration is minimized because polling is performed during cell transfer.

In ATM mode, all unused  $u\_rxclav$  inputs require connection to ground.

**Note:** The  $u\_rxenb$  outputs are high impedance during powerup and reset. An attached PHY may interpret this high-impedance state as an enable; however, the T8207 is not ready to properly handle input data during this time. Attach pull-up resistors to these outputs if a problem is anticipated.

When the T8207 is in ATM mode, if bit 6 ( $inhibit\_rxuto\_fifo\_overrun$ ) of register 0112h is set to '1,' the T8207 prevents the RX UTOPIA FIFO from overflowing by deasserting its  $rx\_enb^*$  signal even though the  $rx\_clav$  signal is high when polled, **if** the RX UTOPIA FIFO is considered full. If this bit is cleared to '0,' the  $rx\_enb^*$  signal is not deasserted even if the RX UTOPIA FIFO is considered full.

## 9 UTOPIA Interface (continued)

### 9.2 Outgoing UTOPIA Cell Interface

#### 9.2.1 Outgoing PHY Mode (Cells Sent by T8207)

In PHY mode, only one enable ( $u\_txenb^*[0]$ ) signal and one cell available ( $u\_txclav[0]$ ) signal are used. The  $u\_txenb^*[0]$  signal is an input connected to the ATM layer's RxEnb\* signal, and the  $u\_txclav[0]$  signal is an output connected to the ATM layer's RxClav signal. As a PHY device, the T8207 may use queue group 0 (queues 0, 1, 2, and 3) in the SDRAM and TX UTOPIA cell buffer. The  $div\_queue$  bits in the main configuration 2 register (address 0112h) may be programmed to "000" for 4 queues or "101" for 1 queue, and the  $port\_rte[63:0]$  bits in the TX PHY FIFO routing 0, 1, 2, and 3 registers (addresses 017Ch, 017Eh, 017Ah, and 0178h respectively) must be programmed to zero. If only queue 0 is used, configure and use only the queue 0 registers at addresses 0440h and 2000h through 2016h. Also, if only queue 0 is used, program the  $mphy\_select$  bits and  $priority\_select$  bits in the routing information 1, 2, and 3 registers addresses 0200h, 0202h, and 0204h to the zero value of "110000." If queues 0, 1, 2, and 3 are used, configure and use only the queue 0, 1, 2, and 3 registers at addresses 0440h through 0446h and 2000h through 2076h. Also, if queues 0, 1, 2, and 3 are used, only the  $mphy\_select$  bits in the routing information 1 and 2 registers (addresses 0200h and 0202h) must all be programmed to the zero value of "110000."

For UTOPIA level 2 functionality, the PHY address is programmed in the  $addr\_match$  bits of UTOPIA configuration register (address 0114h), and the  $addr\_clav\_en$  bits of the main configuration 2 register (address 0112h) can be programmed to any value mentioned in the register **except** "000." As specified in the UTOPIA level 2 specification, the T8207 drives the  $u\_txclav[0]$  signal during the clock cycle following the one with its address on the  $u\_txaddr$  pins. The  $u\_txclav[0]$  pin goes high impedance when not selected to support MPHY operation. When the  $tx\_utopia\_hi\_z$  bit in the main configuration 1 register (address 0100h) is cleared, the  $u\_txsoc$ ,  $u\_txdata[7:0]$  and  $u\_txprty$  outputs go high impedance when not selected, allowing multiple PHYs to be connected on the same UTOPIA bus. In UTOPIA level 1, the above level 2 bits are not meaningful; therefore, the  $addr\_clav\_en$  bits must be programmed to "000," the  $u\_txaddr$  pins must be grounded, and the  $addr\_match$  bits cleared.

**Note: If the SDRAM is bypassed, the T8207 uses only queue 0 in the TX UTOPIA cell buffer.**

**Note:** Even though the outgoing (egress) queues are 0—3, the egress port is determined by the address match bits in register 0114h.

## 9 UTOPIA Interface (continued)

### 9.2.2 Outgoing ATM Mode (Cells Sent by T8207)

In ATM mode, the T8207 may connect to PHY devices that either meet level 1 or level 2 UTOPIA specifications. If connection is to devices that meet only UTOPIA level 1 specifications, the T8207 may access up to four of these PHY devices using the four enable ( $u\_txenb[3:0]$ ) and cell available ( $u\_txclav[3:0]$ ) signals. Polling of the cell available signals occurs while the current cell is transmitted.

If the T8207 connects to PHY devices meeting level 2 UTOPIA specifications, one TxCLAV/TxENB pair supports up to 16 PHY ports. For 32 PHY ports, two TxCLAV/TxENB pairs support two groups of 16 PHY ports for a total of 32 PHY ports.

In ATM MPHY mode, the  $u\_txdata[7:0]$ ,  $u\_txaddr[4:0]$ ,  $u\_txsoc$ , and  $u\_txprty$  outputs are connected to each PHY port. In addition, the T8207 generates the address ( $u\_txaddr[4:0]$ ) signals, permitting selection and arbitration among the ports. The number of address lines used in the connection may vary from one to four giving a maximum address value of 15. (All five address lines must be connected to provide for the NULL address.) Refer to Section 9.6, UTOPIA Pin Modes, for more information about the possible combinations of address, cell available, and enable signals. The UTOPIA specification for operation with one TxClav and one RxClav is used when the T8207 connects to multiple UTOPIA level 2 PHY devices.

In ATM mode, all unused  $u\_txclav$  inputs require connection to ground.

**Note:** The  $u\_txenb$  outputs are high impedance during powerup and reset. An attached PHY may interpret this high-impedance state as an enable; however, the T8207 is not ready to send data during this time. Attach pull-up resistors to these outputs if a problem is anticipated.

The TX UTOPIA cell buffer holds the next cells to be transmitted onto the UTOPIA bus. This TX UTOPIA cell buffer, which holds 128 cells, may be divided into 1, 4, 8, 16, 32, or 64 queues using the  $div\_queue$  bits in the main configuration 2 register (address 0112h). The number of ports that the T8207 supports determines the number of queues that should be chosen. (See Section 9.6, UTOPIA Pin Modes.) The number of cells per queue, held by the buffer, is determined by dividing 128 (maximum number of cells that TX UTOPIA cell buffer holds) by the number of queues selected (e.g., two cells per queue for 64 queues and 32 cells per queue for 4 queues).

If the T8207\_sel bit in the main configuration 2 register, Table 59, is set, each port is assigned four queues in the TX UTOPIA cell buffer except in the case of 32 ports. For 32 ports, each port is assigned two queues. Each group of four queues is priority encoded where the lowest-numbered queue has the highest priority. Groups of four queues are shared among two ports as follows:

- Queues 0—3 are shared between ports 0 and 1.
- Queues 4—7 are shared between ports 2 and 3.
- Queues 8—11 are shared between ports 4 and 5.
- Queues 12—15 are shared between ports 6 and 7.
- Queues 16—19 are shared between ports 8 and 9.
- Queues 20—23 are shared between ports 10 and 11.
- Queues 24—27 are shared between ports 12 and 13.
- Queues 28—31 are shared between ports 14 and 15.
- Queues 32—35 are shared between ports 16 and 17.
- Queues 36—39 are shared between ports 18 and 19.
- Queues 40—43 are shared between ports 20 and 21.
- Queues 44—47 are shared between ports 22 and 23.
- Queues 48—51 are shared between ports 24 and 25.
- Queues 52—55 are shared between ports 26 and 27.
- Queues 56—59 are shared between ports 28 and 29.
- Queues 60—63 are shared between ports 30 and 31.

## 9 UTOPIA Interface (continued)

If the T8207\_sel bit is set and 16 or less ports are used, then each port uses four queues with priorities from 0 to 3, where 0 is the highest priority and 3 is the lowest priority. The lowest-numbered queue in the group of four is assigned priority 0, and the highest-numbered queue in the group is assigned priority 3. For 32 PHY ports, any of the four queues in each group may be assigned to either the even- or odd-numbered port. An example, which will be called **normal 32-port mode**, assigns queues with priorities of 0 and 2 to the even-numbered ports and queues with priorities of 1 and 3 to the odd-numbered ports. See the port\_rte[63:48], port\_rte[47:32], port\_rte[31:16] and port\_rte[15:0] bits in the TX PHY FIFO routing 3, 2, 0, and 1 (addresses 0178h, 017Ah, 017Ch, and 017Eh) registers, respectively. Figure 11 illustrates the selection of ports when 32 are used.

If the T8207\_sel bit in the main configuration 2 register (Table ) is cleared, the device cannot be configured to access 32 PHY ports. Only 16 PHYs and 32 queues are available. For 16 PHY ports, any of the four queues in each group may be assigned to either the even- or odd-numbered port. An example, which will be called **normal 16-port mode**, assigns queues with priorities of 0 and 2 to the even-numbered ports and queues with priorities of 1 and 3 to the odd-numbered ports.

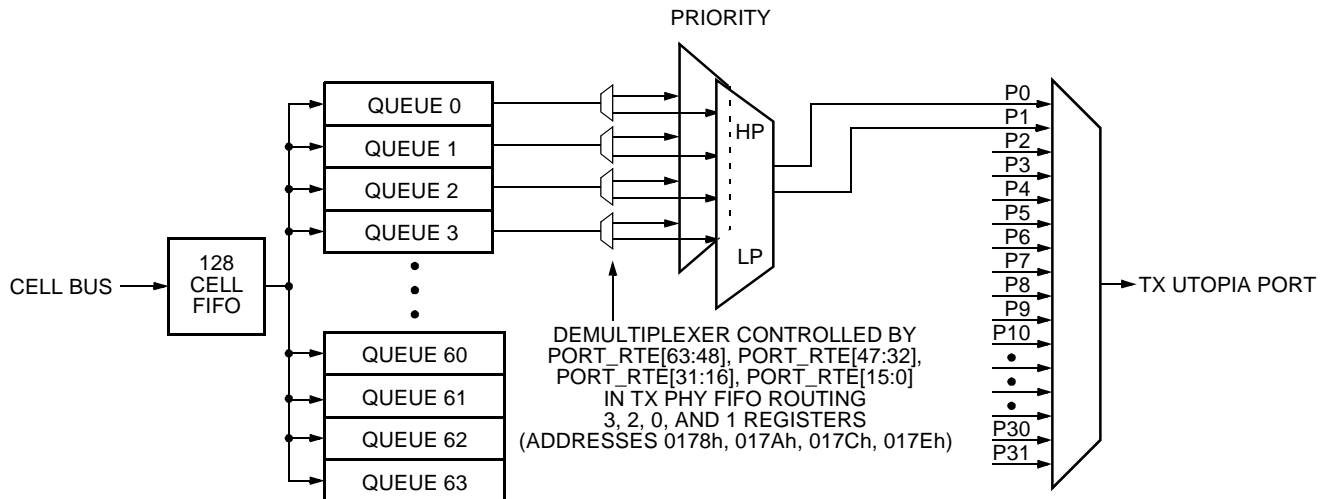

5-7784.b F

Figure 11. Queue Priority Multiplexing

The TX UTOPIA cell buffer is kept full by cells transferred to it from the SDRAM. Each port has equal priority for transmitting onto the UTOPIA bus. The cell transmitted by any one port is determined by the priority of its queues with cells waiting to be transmitted. In addition, the number of clock cycles wasted for bus arbitration is minimized because polling is performed during cell transfer.

Cells arriving from the cell bus have their header error check (HEC) bytes removed. Therefore, the T8207 calculates the HEC and inserts it into each cell before transmitting it onto the UTOPIA bus. See Figure 12.

### 9.3 Counters

For each port selected in MPHY mode, two 16-bit registers (in\_cnt\_phyX[31:16] and in\_cnt\_phyX[15:0] in Table 102) are used as a 32-bit free-running incoming cell counter. Each port's counter counts valid and misrouted incoming cells. Incoming cells are not counted if they encounter an ignore (I) bit in their translation records that is '1' or if their VPI and/or VCI are out of range. The counter for port 0 is found at addresses 0700h and 0702h. See Table 102 in Section 14.3.2.3, RX UTOPIA Monitoring, for the addresses of other ports' incoming cell counters.

Also, for each port selected in MPHY mode, two 16-bit registers (out\_cnt\_phyX[31:16] and out\_cnt\_phyX[15:0] in Table 101) are used as a 32-bit free-running outgoing cell counter. Each port's counter counts all outgoing cells to the UTOPIA bus. The counter for port 0 is found at addresses 0600h and 0602h. See Table 101 in Section 14.3.2.2, TX UTOPIA Monitoring, for the addresses of other ports' outgoing cell counters.

## 9 UTOPIA Interface (continued)

### 9.4 55-Byte UTOPIA Mode

In this special UTOPIA mode, the T8207 transmits a 55-byte cell, as opposed to 53 bytes, on the UTOPIA bus. The extra 2 bytes are the tandem routing header received with the cell from the cell bus. These 2 bytes are appended to the beginning of the cell with the tandem routing header [15:8] byte first, followed by the tandem routing header [7:0] byte. Clearing the `sp_utopia_sel*` bit in the main configuration 1 register (address 0100h) enables this mode. The start of cell signal (`u_txsoc`) is asserted only once with the first tandem routing header byte. The T8207 may be configured for 55-byte UTOPIA mode whether it is an ATM or PHY device.

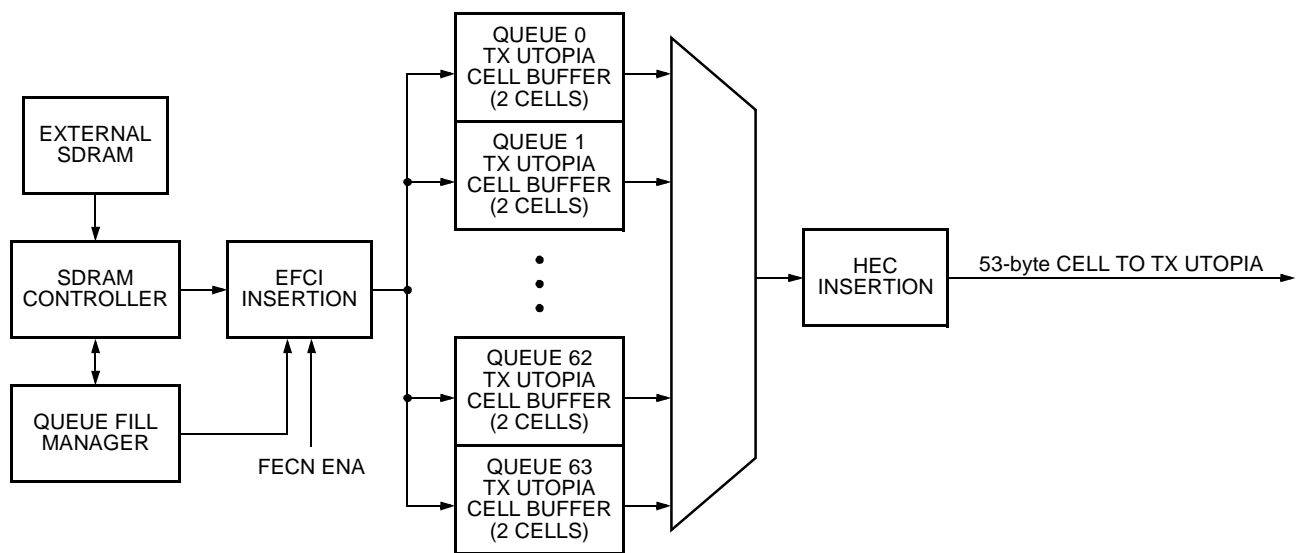

Figure 12. TX UTOPIA Cell Handling

5-7783aF

## 9 UTOPIA Interface (continued)

### 9.5 Shared UTOPIA Mode

The shared UTOPIA mode supports up to 16 PHY ports using only 32 queues, and it allows two T8207 devices on different cell buses to share the same UTOPIA bus. This shared mode can be used to provide redundancy or to increase the cell bus system capacity. One T8207 device is configured as master and the other as slave, using the `slave_en` bit in the main configuration/control register (address 0110h). The master and the slave communicate to each other through the shared UTOPIA output (`u_shr_o`) and input (`u_shr_i`) pins. For the master, `u_shr_o` functions as the grant output, and `u_shr_i`, as the request input. For the slave, `u_shr_o` functions as the request output, and `u_shr_i`, as the grant input. Only T8207 devices configured for ATM mode may be used in shared UTOPIA mode. This configuration is supported for both UTOPIA level 1 and 2 configurations. The configuration for the `addr_clav_en` bits must be the same in both devices in `MCF2` (0112h) and `port_rte` (0178h to 017Eh) registers.

**Note:** The T8207 will support shared UTOPIA mode for only up to 32 queues. To use shared UTOPIA with 16 PHY ports, only 32 queues, shared between even and odd ports can be used, which translates to a zero value for the `T8207_sel` bit (Table 59).

The TX UTOPIA cell buffers in the master and the slave may be divided into the same number of queues or different number of queues. The `mast_queue_in[31:16]`, `mast_queue_in[15:0]`, `slav_queue_in[31:16]`, and `slav_queue_in[15:0]` bits in the master queue 0 (address 015Ch), master queue 1 (address 015Eh), slave queue 0 (address 016Ch), and slave queue 1 (address 016Eh) registers, respectively, must be configured in the master device. These bits indicate which queues in the master and which queues in the slave are enabled. The master's priority algorithm uses this information to determine which waiting cell should be transmitted. The slave queue 0 and 1 registers are ignored in the slave.

The transmit operation in shared UTOPIA mode is illustrated in Figure 13. For the transmit interface, all enable, start of cell, and data signals occur relative to the low-going start of grant signal from the master. The start of grant signal occurs every 60 clock cycles and is always preceded by at least six clock cycles of ones.

Both devices transmit on the TX UTOPIA bus; the master arbitrates the bus and grants the slave access via its `u_shr_o` pin. When the slave has cells waiting for transmission, it makes a request for each queue (up to 32) that contains cells. To make this request, the slave pulls its request output low for one clock cycle during the queue's request period. The request period for each queue is assigned relative to the master's start of grant signal. The request period for queue zero occurs ten clock cycles after the start of grant and is followed by the request period for queue one. The master uses the received queue number and a priority algorithm to determine if a slave's cell should be transmitted before one of its own. Both master and slave have an equal chance to transmit cells if the cells have equal priority. The master grants the slave's request by sending 8 bits of serial data, clocked at the rate of the UTOPIA transmit clock, to its grant output. The first bit is the low-going grant signal. The next 5 bits designate the queue number of the cell to be transmitted. The queue number is sent most significant bit first. The next bit is the valid bit; it is low if this grant is valid. Finally, the last bit (`R[0]`) is reserved for future use. The slave then has 53 cycles or 55 cycles to transmit its cell depending on the mode.

In UTOPIA receive mode, the master controls the UTOPIA bus, and the slave only monitors the bus. Both master and slave receive all cells and use their individual look-up tables to determine which cells are destined for their cell bus. The master controls the enable (`u_rxenb[3:0]`) and address (`u_rxaddr[4:0]`) signals to the UTOPIA bus. The slave monitors these signals to determine when the cell starts and which port is sending the cell.

In shared UTOPIA mode, the master always drives the `u_rxaddr[4:0]`, `u_txaddr[4:0]`, `u_txsoc`, `u_rxenb*[3:0]`, and `u_txenb*[3:0]` signals. These signals become high impedance on the slave when the `slave_en` bit in the main configuration/control register (address 0110h) is set. Both the master and slave drive the `u_txprty` and `u_txdata[7:0]` signals when they transmit a cell; therefore, these signals must transition to a high-impedance state when not active. Clear the `tx_utopia_hi_z` bit in the main configuration 1 register (address 0100h) to force the `u_txprty` and `u_txdata[7:0]` signals to a high-impedance state when inactive.



9 UTOPIA Interface (continued)

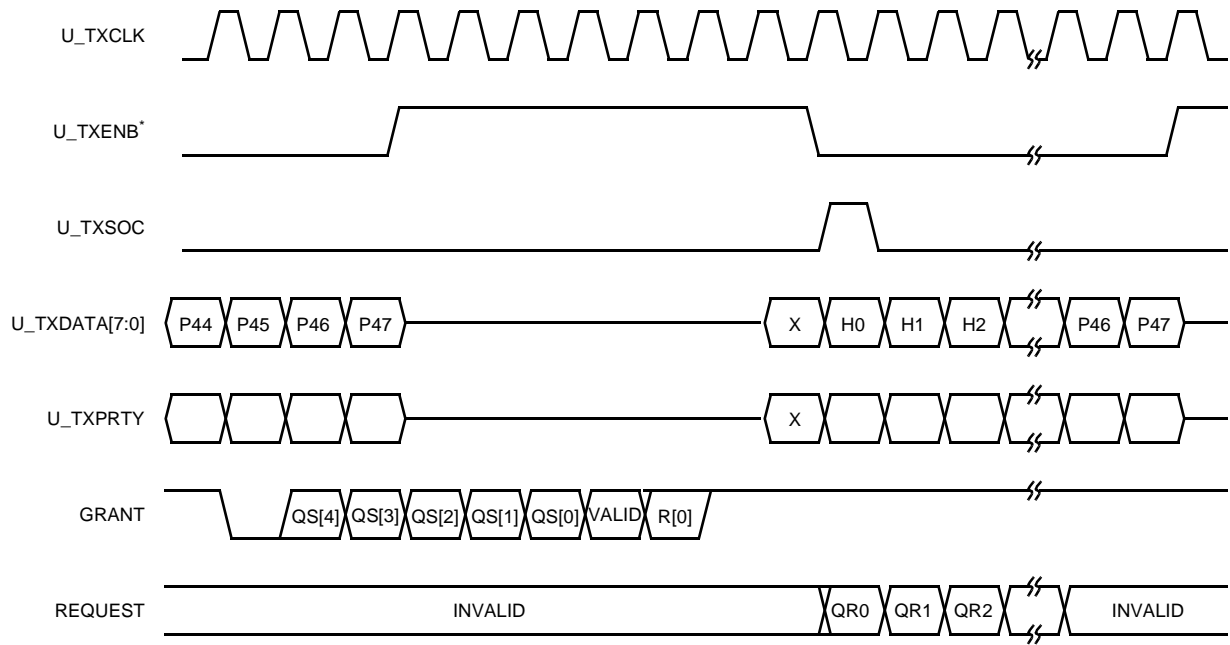

5-7786aF

Figure 13. TX UTOPIA Bus Sharing

## 9 UTOPIA Interface (continued)

### 9.6 UTOPIA Pin Modes

In multi-PHY mode, the T8207 interfaces with up to 32 PHY ports. Each port is numbered and accessed using a certain combination of the cell available/enable (Clav/Enb\*) and address (Addr) signals. The addr\_clav\_en bits in the main configuration 2 register (address 0112h) are used to select this combination of cell available/enable and address signals. Table 16 indicates the port numbering for each of the possible configurations.

The first selection of zero address and four cell available/enable signals (a value of “000” in bits 2:0 of register 0112h) is used for connection to UTOPIA level one devices. Use this selection to connect from one to four PHY devices to the T8207 in ATM mode. If only one PHY is connected, any of the four cell available signals may be connected to the PHY. For two PHY devices, connect any two (internal port number must be matched to the clav being used). All unused u\_rxclav inputs require connection to ground. Four queues are allocated per PHY in this configuration.

The second selection of one address and four cell available/enable signals (a value of “010” in bits 2:0 of register 0112h) is used for connection to UTOPIA level two devices. The selection may be used for up to four PHY groups of two ports each. (See Appendix 1 of The ATM Forum Technical Committee UTOPIA Level 2, Version 1.0 specification.) All unused u\_rxclav inputs require connection to ground. Four queues are allocated per PHY in this configuration.

The third selection of two address and four cell available/enable signals (a value of “101” in bits 2:0 of register 0112h) is used for connection to four UTOPIA level 2 PHY groups of four ports each. If the T8207\_sel bit in register 0112h is set, four queues are allocated per PHY. If the T8207\_sel bit is cleared, two queues are allocated per PHY if the **normal** 16-port mode described in Section 11.4, Queuing is used or a programmable number of queues can be allocated per PHY based on the settings in registers 017Ch—017Eh.

The fourth selection of two address and two cell available/enable signals (a value of “100” in bits 2:0 of register 0112h) is used for connection to two UTOPIA level 2 PHY groups of four ports each. All unused u\_rxclav inputs require connection to ground. Four queues are allocated per PHY in this configuration.

The fifth selection of three address and two cell available/enable signals (a value of “111” in bits 2:0 of register 0112h) is used for connection to two UTOPIA level 2 PHY groups of eight ports each. All unused u\_rxclav inputs require connection to ground. If the T8207\_sel bit in register 0112h is set, four queues are allocated per PHY. If the T8207\_sel bit is cleared, two queues are allocated per PHY if the **normal** 16-port mode described in Section 11.4, Queuing is used or a programmable number of queues can be allocated per PHY based on the settings in registers 017Ch—017Eh.

The sixth selection of three address and one cell available/enable signals (a value of “110” in bits 2:0 of register 0112h) is used for connection to eight UTOPIA level 2 PHY ports. All unused u\_rxclav inputs require connection to ground. Four queues are allocated per PHY in this configuration.

The seventh selection of four address and one cell available/enable signals (a value of “001” in bits 2:0 of register 0112h) is used for connection to sixteen UTOPIA level 2 PHY ports. All unused u\_rxclav inputs require connection to ground. If the T8207\_sel bit in register 0112h is set, four queues are allocated per PHY. If the T8207\_sel bit is cleared, two queues are allocated per PHY if the **normal** 16-port mode described in Section 11.4, Queuing is used or a programmable number of queues can be allocated per PHY based on the settings in registers 017Ch—017Eh.

Finally, the eighth selection of four address and two cell available/enable signals (a value of “011” in bits 2:0 of register 0112h) is used for connection to two UTOPIA Level 2 PHY groups of 16 ports each. All unused u\_rxclav inputs require connection to ground. The T8207\_sel bit in register 0112h must be set to ‘1’ for this mode. Two queues are allocated per PHY, if the **normal** 32-port mode described in Section 11.4, Queuing is used or a programmable number of queues can be allocated per PHY based on the settings in registers 0178h—017Eh.

9 UTOPIA Interface (continued)

Table 16. Port Numbering for MPHY Configurations

# of addr	# of clav/enb*	Ports 0—7							
		Port 0	Port 1	Port 2	Port 3	Port 4	Port 5	Port 6	Port 7
0	4	enb*[0], clav[0], addr = 0	—	enb*[1], clav[1], addr = 0	—	enb*[2], clav[2], addr = 0	—	enb*[3], clav[3], addr = 0	—
1	4	enb*[0], clav[0], addr = 0	—	enb*[0], clav[0], addr = 2	—	enb*[1], clav[1], addr = 0	—	enb*[1], clav[1], addr = 2	—
2	4	enb*[0], clav[0], addr = 0	enb*[0], clav[0], addr = 1	enb*[0], clav[0], addr = 2	enb*[0], clav[0], addr = 3	enb*[1], clav[1], addr = 0	enb*[1], clav[1], addr = 1	enb*[1], clav[1], addr = 2	enb*[1], clav[1], addr = 3
2	2	enb*[0], clav[0], addr = 0	—	enb*[0], clav[0], addr = 2	—	enb*[0], clav[0], addr = 4	—	enb*[0], clav[0], addr = 6	—
3	2	enb*[0], clav[0], addr = 0	enb*[0], clav[0], addr = 1	enb*[0], clav[0], addr = 2	enb*[0], clav[0], addr = 3	enb*[0], clav[0], addr = 4	enb*[0], clav[0], addr = 5	enb*[0], clav[0], addr = 6	enb*[0], clav[0], addr = 7
3	1	enb*[0], clav[0], addr = 0	—	enb*[0], clav[0], addr = 2	—	enb*[0], clav[0], addr = 4	—	enb*[0], clav[0], addr = 6	—
4	1	enb*[0], clav[0], addr = 0	enb*[0], clav[0], addr = 1	enb*[0], clav[0], addr = 2	enb*[0], clav[0], addr = 3	enb*[0], clav[0], addr = 4	enb*[0], clav[0], addr = 5	enb*[0], clav[0], addr = 6	enb*[0], clav[0], addr = 7
4	2	enb*[0], clav[0], addr = 0	enb*[0], clav[0], addr = 1	enb*[0], clav[0], addr = 2	enb*[0], clav[0], addr = 3	enb*[0], clav[0], addr = 4	enb*[0], clav[0], addr = 5	enb*[0], clav[0], addr = 6	enb*[0], clav[0], addr = 7
# of addr	# of clav/enb*	Ports 8—15							
		Port 8	Port 9	Port 10	Port 11	Port 12	Port 13	Port 14	Port 15
0	4	—	—	—	—	—	—	—	—
1	4	enb*[2], clav[2], addr = 0	—	enb*[2], clav[2], addr = 2	—	enb*[3], clav[3], addr = 0	—	enb*[3], clav[3], addr = 2	—
2	4	enb*[2], clav[2], addr = 0	enb*[2], clav[2], addr = 1	enb*[2], clav[2], addr = 2	enb*[2], clav[2], addr = 3	enb*[3], clav[3], addr = 0	enb*[3], clav[3], addr = 1	enb*[3], clav[3], addr = 2	enb*[3], clav[3], addr = 3
2	2	enb*[1], clav[1], addr = 0	—	enb*[1], clav[1], addr = 2	—	enb*[1], clav[1], addr = 4	—	enb*[1], clav[1], addr = 6	—
3	2	enb*[1], clav[1], addr = 0	enb*[1], clav[1], addr = 1	enb*[1], clav[1], addr = 2	enb*[1], clav[1], addr = 3	enb*[1], clav[1], addr = 4	enb*[1], clav[1], addr = 5	enb*[1], clav[1], addr = 6	enb*[1], clav[1], addr = 7
3	1	enb*[0], clav[0], addr = 8	—	enb*[0], clav[0], addr = 10	—	enb*[0], clav[0], addr = 12	—	enb*[0], clav[0], addr = 14	—
4	1	enb*[0], clav[0], addr = 8	enb*[0], clav[0], addr = 9	enb*[0], clav[0], addr = 10	enb*[0], clav[0], addr = 11	enb*[0], clav[0], addr = 12	enb*[0], clav[0], addr = 13	enb*[0], clav[0], addr = 14	enb*[0], clav[0], addr = 15
4	2	enb*[0], clav[0], addr = 8	enb*[0], clav[0], addr = 9	enb*[0], clav[0], addr = 10	enb*[0], clav[0], addr = 11	enb*[0], clav[0], addr = 12	enb*[0], clav[0], addr = 13	enb*[0], clav[0], addr = 14	enb*[0], clav[0], addr = 15

9 UTOPIA Interface (continued)

Table 16. Port Numbering for MPHY Configurations (continued)

# of addr	# of clav/enb*	Ports 16—23							
		Port 16	Port 17	Port 18	Port 19	Port 20	Port 21	Port 22	Port 23
0	4	—	—	—	—	—	—	—	—
1	4	—	—	—	—	—	—	—	—
2	4	—	—	—	—	—	—	—	—
2	2	—	—	—	—	—	—	—	—
3	2	—	—	—	—	—	—	—	—
3	1	—	—	—	—	—	—	—	—
4	1	—	—	—	—	—	—	—	—
4	2	enb*[1], clav[1], addr = 0	enb*[1], clav[1], addr = 1	enb*[1], clav[1], addr = 2	enb*[1], clav[1], addr = 3	enb*[1], clav[1], addr = 4	enb*[1], clav[1], addr = 5	enb*[1], clav[1], addr = 6	enb*[1], clav[1], addr = 7
# of addr	# of clav/enb*	Ports 24—31							
		Port 24	Port 25	Port 26	Port 27	Port 28	Port 29	Port 30	Port 31
0	4	—	—	—	—	—	—	—	—
1	4	—	—	—	—	—	—	—	—
2	4	—	—	—	—	—	—	—	—
2	2	—	—	—	—	—	—	—	—
3	2	—	—	—	—	—	—	—	—
3	1	—	—	—	—	—	—	—	—
4	1	—	—	—	—	—	—	—	—
4	2	enb*[1], clav[1], addr = 8	enb*[1], clav[1], addr = 9	enb*[1], clav[1], addr = 10	enb*[1], clav[1], addr = 11	enb*[1], clav[1], addr = 12	enb*[1], clav[1], addr = 13	enb*[1], clav[1], addr = 14	enb*[1], clav[1], addr = 15

## 9 UTOPIA Interface (continued)

### 9.7 UTOPIA Clocking

All TX UTOPIA signals in the T8207 are clocked on the rising edge of the TX UTOPIA clock, and all RX UTOPIA signals are clocked on the rising edge of the RX UTOPIA clock.

The UTOPIA specifications state that the ATM layer supplies the transmit and receive UTOPIA interface clocks to the PHY layers. The T8207 may be configured to drive these clocks or to be driven by them.

In the T8207, the clocks for transmit and receive UTOPIA interfaces may be independently derived from several sources. In addition, each of these clocks may be independently configured. The TX UTOPIA clock configuration (address 010Ch) and RX UTOPIA clock configuration (address 010Eh) registers are used to select and configure the transmit UTOPIA interface and the receive UTOPIA interface clocks, respectively. See these register descriptions for more information.

## **10 Cell Bus Interface**

### **10.1 General Architecture**

The high bandwidth, 32-bit cell bus is used to interconnect T8207 devices. Up to 32 devices may be connected to the bus, and cell exchange may occur between any of these devices. Each cell bus frame is 16 clock cycles, and during these 16 cycles, one cell is transmitted. The T8207 is designed to operate with a maximum cell bus frequency of 66 MHz, which translates to a cell bandwidth of 1.7 Gbits/s. The maximum achievable frequency for a given bus implementation is dependent on loading and other design considerations.

In addition to the 32 bits of data, the cell bus uses four additional control signals. The four signals include a read clock, a write clock, a frame synchronization signal, and an acknowledge signal.

The read and write clocks (*cb\_rc\** and *cb\_wc\** pins, respectively) establish the timing for reading and writing cells on the bus and are generated from an external clock source. The read clock is used to read the cell from the cell bus, and the write clock is used to write the cell to the cell bus. Because all devices on the cell bus read and write on the same clock edge, the write clock is delayed slightly, relative to the read clock, to ensure sufficient data hold time.

The active-low frame sync (*cb\_fs\**) is generated by the bus arbiter and indicates the first cycle of the cell bus frame in 16 user mode or the first cycle of two cell bus frames for 32 user mode. This signal is generated every 16 clock cycles for 16 user mode or every 32 clock cycles for 32 user mode.

The acknowledge (*cb\_ack\**) signal is used to acknowledge the successful receipt of a cell. This signal is asserted low during the next request cycle by the T8207 that receives the cell. This signal is not asserted for multicast or broadcast cells. In the event of an overflow in the control cell RX FIFO, the loopback FIFO, the TX PHY FIFO, or the cell bus input FIFO, the acknowledge signal will assert low. In the case of an overflow, this signal will not assert low for multicast and broadcast cells.

When *cb\_disable\** is asserted, the device can receive data on the *cb\_d\*[31:0]* but cannot transmit data. The device cannot assert the *cb\_ack\** even when a valid cell is received from the cell bus, if *cb\_disable\** is asserted.

Several T8207 devices may reside on the cell bus, but one device must be configured as bus arbiter by clearing the *cb\_arb\_sel* bit in the cell bus configuration/status register (address 0130h) or by pulling the *arb\_en\** lead low. The cell bus arbiter receives requests for access to the bus from all resident devices during the first cycle of the cell bus frame and grants one of these requests during the last cycle of the cell bus frame. Before issuing the grant and while a cell is transmitted on the cell bus, the arbiter executes its arbitration algorithm to determine the next device to transmit on the bus. The arbiter also generates the frame synchronization signal. Software shall designate only one device as cell bus arbiter, at any given time, to ensure proper operation of the bus.

A 5-bit unit address is assigned to each device (up to 32) on the bus. Each device uses this address to request cell transmission and to identify incoming cells destined for them. Each device is given a unique unit address by individually tying each address (*ua\*[4:0]*) input high or low. The unit address inputs are active-low; therefore, a device with its *ua\*[4:0]* inputs tied to "10000" has address 15. The device makes a cell transmission request by driving the two assigned bits during the request cycle, which is the first cycle of a frame. For example, device 15 uses bits 30 and 31 of the request cycle as its request bits. (See Section 10.2, Cell Bus Frames.) Also, each device uses its unit address to determine if a received cell is destined for it. (See Section 10.3, Cell Bus Routing Headers.)

## 10 Cell Bus Interface (continued)

The cell bus may be configured for 16-user or 32-user mode using the `cb_usr_mode` bit in the cell bus configuration/status register (address 0130h). In 16-user mode, all 16 devices assert their transmission requests during the first cycle of each frame, and the transmission grant for the next frame is given during the last cycle of the frame. In 32-user mode, the frame synchronization signal is asserted every two cell bus frames. The two frames are termed the odd and even frames. The frame synchronization signal marks the beginning of the even frame, and the odd frame starts 16 clock cycles later. During the request cycle of the even frame, devices zero through 15 assert their transmission requests, and during the request cycle of the odd frame, devices 16 through 31 assert theirs. Requests received from odd and even frames are serviced as a group, and grants are given in the order that the requests are received with the highest priority serviced first with the same priority requests serviced using a round-robin algorithm. Transmission grants for the next frame are always given at the end of the current frame.

Cells to be transmitted onto the cell bus come from three sources internal to the T8207. Data cells from the UTOPIA bus are placed in the RX PHY FIFO to await transmission onto the cell bus. Control cells from the microprocessor wait in the control cell TX FIFO, and loopback cells from the cell bus wait in the loopback FIFO. Cells from these three FIFOs are priority multiplexed onto the cell bus output FIFO to be transmitted onto the cell bus.

Optional high priority can be established for data cells or control cells sent to the cell bus. If bit 9 in register 0130h is cleared to '0' then cells from the RX PHY FIFO have the highest priority, cells from the control cell TX FIFO have next highest, and finally, cells from the loopback FIFO have the lowest. If bit 9 in register 0130h is set to '1,' then cells from the control cell TX FIFO have the highest priority, cells from the RX PHY FIFO have the next highest priority, and finally, cells from the loopback FIFO have the lowest priority. This bit on default is '0.'

Incoming cells may be broadcast, multicast, or single address types. The T8207 receiving device accepts single address cells with an address field in the cell bus routing header that matches the device's unit address. In addition, the device accepts all broadcast cells and certain multicast cells that it is configured to accept. (See Section 10.3.4, Multicast Routing (continued).) Before a cell is accepted, a check is done on the previous grant to verify whether it is a valid grant or not. The receiving device verifies the cell bus routing header cyclic redundancy check (CRC-4) value in the least significant 4 bits of the cell bus routing header. It also verifies the bit interleave parity (BIP-8) value from bits 24 to 31 of the last cell bus frame cycle. If either is corrupt, the cell is discarded. If kept, cells are routed to the loopback FIFO, control FIFO, or TX PHY FIFO, based on the information in its cell bus routing header. See Section 10.3, Cell Bus Routing Headers.

## 10 Cell Bus Interface (continued)

### 10.2 Cell Bus Frames

A cell bus frame is always 16 clock cycles. The cell bus frame has three sections (request, bus cell, and grant). During the request section, which is the first clock cycle of the frame, 16 devices assert their transmission requests onto the bus. During the bus cell section, which is the next 14 clock cycles, a cell is transmitted on the cell bus. This bus cell includes the cell bus routing header, the optional tandem routing header, and the 52-byte body of the cell. During the grant section, which is the last clock cycle of the frame, the grant is asserted, indicating which device may transmit its cell during the next frame. Also, during this last clock cycle, a parity vector is placed on the bus by the transmitting device so that error detection can be performed on the cell. Figure 14 illustrates the format for the cell bus frame.

	31								16	15								0			
CYCLE 0	U15	U14	U13	U12	U11	U10	U9	U8	U7	U6	U5	U4	U3	U2	U1	U0					
CYCLE 1	CELL BUS ROUTING HEADER								TANDEM ROUTING HEADER												
CYCLE 2	GFC/ VPI[11:8]		VPI[7:0]				VCI[15:0]								PTI		C L P				
CYCLE 3	PAYLOAD BYTE 0				PAYLOAD BYTE 1				PAYLOAD BYTE 2				PAYLOAD BYTE 3								
CYCLE 4	PAYLOAD BYTE 4				PAYLOAD BYTE 5				PAYLOAD BYTE 6				PAYLOAD BYTE 7								
CYCLE 5	PAYLOAD BYTE 8				PAYLOAD BYTE 9				PAYLOAD BYTE 10				PAYLOAD BYTE 11								
CYCLE 6	PAYLOAD BYTE 12				PAYLOAD BYTE 13				PAYLOAD BYTE 14				PAYLOAD BYTE 15								
CYCLE 7	PAYLOAD BYTE 16				PAYLOAD BYTE 17				PAYLOAD BYTE 18				PAYLOAD BYTE 19								
CYCLE 8	PAYLOAD BYTE 20				PAYLOAD BYTE 21				PAYLOAD BYTE 22				PAYLOAD BYTE 23								
CYCLE 9	PAYLOAD BYTE 24				PAYLOAD BYTE 25				PAYLOAD BYTE 26				PAYLOAD BYTE 27								
CYCLE 10	PAYLOAD BYTE 28				PAYLOAD BYTE 29				PAYLOAD BYTE 30				PAYLOAD BYTE 31								
CYCLE 11	PAYLOAD BYTE 32				PAYLOAD BYTE 33				PAYLOAD BYTE 34				PAYLOAD BYTE 35								
CYCLE 12	PAYLOAD BYTE 36				PAYLOAD BYTE 37				PAYLOAD BYTE 38				PAYLOAD BYTE 39								
CYCLE 13	PAYLOAD BYTE 40				PAYLOAD BYTE 41				PAYLOAD BYTE 42				PAYLOAD BYTE 43								
CYCLE 14	PAYLOAD BYTE 44				PAYLOAD BYTE 45				PAYLOAD BYTE 46				PAYLOAD BYTE 47								
CYCLE 15	BIT INTERLEAVE PARITY				—	—	—	—	—	—	—	—	—	—	—	—	—	—	G P	G E	GRANT NUMBER

**Figure 14. Cell Bus Frame Format (Bit Positions for 16 User Mode)**



10 Cell Bus Interface (continued)

	31									16	15							0			
CYCLE 0	U15	U14	U13	U12	U11	U10	U9	U8	U7	U6	U5	U4	U3	U2	U1	U0					
CYCLE 1	CELL BUS ROUTING HEADER								TANDEM ROUTING HEADER												
CYCLE 2	GFC/ VPI[11:8]		VPI[7:0]				VCI[15:0]						PTI		C L P						
CYCLE 3	PAYLOAD BYTE 0				PAYLOAD BYTE 1				PAYLOAD BYTE 2				PAYLOAD BYTE 3								
CYCLE 4	PAYLOAD BYTE 4				PAYLOAD BYTE 5				PAYLOAD BYTE 6				PAYLOAD BYTE 7								
CYCLE 5	PAYLOAD BYTE 8				PAYLOAD BYTE 9				PAYLOAD BYTE 10				PAYLOAD BYTE 11								
CYCLE 6	PAYLOAD BYTE 12				PAYLOAD BYTE 13				PAYLOAD BYTE 14				PAYLOAD BYTE 15								
CYCLE 7	PAYLOAD BYTE 16				PAYLOAD BYTE 17				PAYLOAD BYTE 18				PAYLOAD BYTE 19								
CYCLE 8	PAYLOAD BYTE 20				PAYLOAD BYTE 21				PAYLOAD BYTE 22				PAYLOAD BYTE 23								
CYCLE 9	PAYLOAD BYTE 24				PAYLOAD BYTE 25				PAYLOAD BYTE 26				PAYLOAD BYTE 27								
CYCLE 10	PAYLOAD BYTE 28				PAYLOAD BYTE 29				PAYLOAD BYTE 30				PAYLOAD BYTE 31								
CYCLE 11	PAYLOAD BYTE 32				PAYLOAD BYTE 33				PAYLOAD BYTE 34				PAYLOAD BYTE 35								
CYCLE 12	PAYLOAD BYTE 36				PAYLOAD BYTE 37				PAYLOAD BYTE 38				PAYLOAD BYTE 39								
CYCLE 13	PAYLOAD BYTE 40				PAYLOAD BYTE 41				PAYLOAD BYTE 42				PAYLOAD BYTE 43								
CYCLE 14	PAYLOAD BYTE 44				PAYLOAD BYTE 45				PAYLOAD BYTE 46				PAYLOAD BYTE 47								
CYCLE 15	BIT INTERLEAVE PARITY								—	—	—	—	—	—	—	—	—	—	G P	G E	GRANT NUMBER
CYCLE 16	U31	U30	U29	U28	U27	U26	U25	U24	U23	U22	U21	U20	U19	U18	U17	U16					
CYCLE 17	CELL BUS ROUTING HEADER								TANDEM ROUTING HEADER												
CYCLE 18	GFC/ VPI[11:8]		VPI[7:0]				VCI[15:0]						PTI		C L P						
CYCLE 19	PAYLOAD BYTE 0				PAYLOAD BYTE 1				PAYLOAD BYTE 2				PAYLOAD BYTE 3								
CYCLE 20	PAYLOAD BYTE 4				PAYLOAD BYTE 5				PAYLOAD BYTE 6				PAYLOAD BYTE 7								
CYCLE 21	PAYLOAD BYTE 8				PAYLOAD BYTE 9				PAYLOAD BYTE 10				PAYLOAD BYTE 11								
CYCLE 22	PAYLOAD BYTE 12				PAYLOAD BYTE 13				PAYLOAD BYTE 14				PAYLOAD BYTE 15								
CYCLE 23	PAYLOAD BYTE 16				PAYLOAD BYTE 17				PAYLOAD BYTE 18				PAYLOAD BYTE 19								
CYCLE 24	PAYLOAD BYTE 20				PAYLOAD BYTE 21				PAYLOAD BYTE 22				PAYLOAD BYTE 23								
CYCLE 25	PAYLOAD BYTE 24				PAYLOAD BYTE 25				PAYLOAD BYTE 26				PAYLOAD BYTE 27								
CYCLE 26	PAYLOAD BYTE 28				PAYLOAD BYTE 29				PAYLOAD BYTE 30				PAYLOAD BYTE 31								
CYCLE 27	PAYLOAD BYTE 32				PAYLOAD BYTE 33				PAYLOAD BYTE 34				PAYLOAD BYTE 35								
CYCLE 28	PAYLOAD BYTE 36				PAYLOAD BYTE 37				PAYLOAD BYTE 38				PAYLOAD BYTE 39								
CYCLE 29	PAYLOAD BYTE 40				PAYLOAD BYTE 41				PAYLOAD BYTE 42				PAYLOAD BYTE 43								
CYCLE 30	PAYLOAD BYTE 44				PAYLOAD BYTE 45				PAYLOAD BYTE 46				PAYLOAD BYTE 47								
CYCLE 31	BIT INTERLEAVE PARITY								—	—	—	—	—	—	—	—	—	—	G P	G E	GRANT NUMBER

Figure 15. Cell Bus Frame Format (Bit Positions for 32 User Mode)

## **10 Cell Bus Interface** (continued)

Devices on the cell bus make their requests during the first cycle of each frame. In 16-user mode, each device asserts a request every frame. In 32-user mode, each device asserts a request every two frames. In 32-user mode, devices with unit addresses 0 through 15 assert their requests during the even frames, and devices with unit addresses 16 through 31 assert their requests during the odd frames. During cycle 0 of their assigned frame, each device drives two of the 32 data bits available. The position of the two request bits for each device is based on the device's unit address. The assigned bit positions for each device are illustrated in Figure 14 and Figure 15 for 16-user and 32-user modes, respectively. For example, in the figures, the device with unit address 0 makes its requests using the 2 bits labeled as U0. Two bits, instead of one, are used for each device so the priority of the request may be included. The priority of the request is set up using the `cb_req_pr` bits in the main configuration/control register (address 0110h). See Table 58 in Section 14.3, Extended Memory Registers, for more information.

During clock cycles 1 through 14, the device that was granted the bus at the end of the previous frame sends its bus cell. The bus cell sent includes the cell bus routing header, the tandem routing header, and the original UTOPIA cell with the header error check (HEC) byte removed. The HEC byte is removed because the cell bus does its own error check over the complete cell using the bit interleave parity byte. The HEC byte is recreated and inserted before the received cell is placed on the UTOPIA bus.

The cell bus routing header indicates the type of the cell (data, control, loopback) and its destination (single, multi-cast, broadcast). See Section 10.3, Cell Bus Routing Headers, for more information on the cell bus routing header structure. The optional tandem routing header is configured by the user.

The 32 bits of the grant section of the frame (clock cycle 15) includes the bit interleave parity (BIP-8) byte, the grant parity bit, the grant enable bit, and the grant number. The most significant 8 bits of the grant section of the frame is the BIP-8 byte. The BIP-8 byte is calculated over 54 bytes starting with the first tandem routing header byte and ending with the last payload byte. To calculate this bit interleave parity, an exclusive-OR operation is performed on the first byte of the tandem routing header and the value "11111111." The exclusive-OR operation then is performed on this result and the following byte. The operation is then repeated with every successive byte through the last data byte of the payload. The resulting byte becomes the BIP-8 byte of the grant section. The next 17 bits of the grant section are unused. The least significant 7 bits of the grant section are used to grant transmission requests. The grant number is located in the least significant 5 bits of the grant section and is the unit address of the device that transmits a cell during the next frame. The grant enable, bit 5, is an active-high signal that indicates if the grant is valid. Finally, the grant parity, bit 6, is the odd parity check calculated over the other six grant bits.

## 10 Cell Bus Interface (continued)

### 10.3 Cell Bus Routing Headers

The cell bus routing header gives information about the cell and its routing. There are seven different formats for cell bus routing headers. See Figure 16. These headers cover broadcast, multicast, and single address routing. A T8207 device on the cell bus accepts all broadcast cells and certain multicast cells that it is configured to accept. Broadcast or multicast routed cells may be data cells or control cells. The T8207 receiving device accepts single address cells with an address field in its cell bus routing header that matches the device's unit address. Cells, routed as single address, may be data, control, or loopback cells.

	b15	b14	b13	b12	b11	b10	b9	b8	b7	b6	b5	b4	b3	b2	b1	b0
MULTICAST CONTROL CELL HEADER	1	1	—	—	MULTICAST NET NUMBER								H			
MULTICAST DATA CELL HEADER	1	0	—	—	MULTICAST NET NUMBER								H			
SINGLE DESTINATION DATA CELL HEADER	0	0	—	—	—	—	0	UNIT ADDRESS					H			
SINGLE DESTINATION CONTROL CELL HEADER	0	1	—	—	—	—	0	UNIT ADDRESS					H			
SINGLE DESTINATION LOOPBACK CELL HEADER	0	0	0	—	—	—	1	UNIT ADDRESS					H			
BROADCAST DATA CELL HEADER	0	0	1	—	—	—	1	—	—	—	—	—	H			
BROADCAST CONTROL CELL HEADER	0	1	1	—	—	—	1	—	—	—	—	—	H			

Figure 16. Cell Bus Routing Headers

The H field (b0 to b3) is the cell bus routing header cyclic redundancy check (CRC-4) calculated over the other 12 bits (b4 to b15) of the header. It is provided for cell bus routing header error detection. When cells arrive from the cell bus, the receiving device calculates the CRC-4 over the most significant 12 bits of the cell bus routing header and compares its calculation to the CRC-4 value stored in the H field of the cell bus routing header. If the two do not match, the cell is discarded.

#### 10.3.1 Control Cells

The microprocessor connected to the T8207 may send control cells to the cell bus by writing the cell to the control cell transmit direct memory at addresses A0h to D7h (or extended memory at addresses 0900h to 0936h). After the cell is written to memory, the microprocessor sets the `cntl_cell_wr` bit in the main configuration/control register (address 0110h). This bit returns to zero when the cell is transmitted and memory is available to load a new control cell into the device.

Control cells accepted from the cell bus are routed to the control cell RX FIFO. The microprocessor connected to the T8207 reads the control cell at the head of the FIFO using the control cell receive direct memory at addresses 60h to 93h (or extended memory at addresses 0800h to 0832h). After the microprocessor reads the cell, it sets the `cntl_cell_rd` bit in the main configuration/control register (address 0110h) to remove the cell from the head of the FIFO.

## **10 Cell Bus Interface** (continued)

### **10.3.2 Data Cells**

Data cells accepted from the cell bus are routed to the TX PHY FIFO. From the TX PHY FIFO, the cell is routed to the appropriate transmit queue using the information about the cell's priority and the queue group to which it is destined. The priority of the cell is indicated by 2 bits obtained from the first 64 bits of the bus cell (cell bus routing header, tandem routing header, and ATM cell header). The position of these 2 bits in the cell are user programmable during configuration using the `prior0_sel[5:0]` and `prior1_sel[5:0]` bits of the routing information 3 register (address 0204h). The queue group to which the cell is destined is indicated by 4 bits obtained from the first 64 bits of the bus cell (cell bus routing header, tandem routing header, and ATM cell header). The position of these 4 bits in these headers are user programmable using the `mphy1_sel[5:0]` and `mphy2_sel[5:0]` bits of the routing information 1 register (address 0200h) and the `mphy3_sel[5:0]` and `mphy0_sel[5:0]` bits of the routing information 2 register (address 0202h). See Tables 90, 91, and 92 in Section 14.3, Extended Memory Registers. None of the priority or MPHY bits are required to be adjacent. For more information on queue groups, see Section 11.4, Queuing.

**If the T8207\_sel bit (Table 59) is zero, the mphy3\_sel[5:0] bits are not used.**

### **10.3.3 Loopback Cells**

A loopback cell may be sent to the cell bus for diagnostic purposes. Initially, the loopback cell is sent from one T8207 (device 1) to a second T8207 (device 2). The second T8207 (device 2) returns the cell to the first T8207 (device 1), or, if desired, the second T8207 (device 2) may send the cell on to one or more entirely different T8207 devices. Device 2 accepts the loopback cell and replaces the most significant 12 bits of the cell bus routing header with the `routing_header` bits in its loopback register (address 0118h). The 12 `routing_header` bits in the loopback register correspond to the upper 12 bits of a single destination control cell header, a multicast control cell header, or a broadcast control cell header. (See Figure 16.)

To create a loopback path from device 1 to device 2, and back to device 1, coordinated control of device 1 and device 2 is needed. First, the microprocessor connected to device 2 sets up the loopback by writing the `routing_header` bits in the loopback register of device 2. The `routing_header` bits indicate a single destination control cell with a unit address field for device 1. Second, the microprocessor connected to device 1 writes a loopback cell to the control cell transmit direct memory (addresses A0h to D7h) of device 1. (See Section 10.3.1, Control Cells of this document.) The cell bus routing header of this cell is the single destination loopback type, and the unit address section of the header contains the address of device 2. To send the loopback cell, a '1' is then written to the `cntl_cell_wr` bit of the main configuration/control register (address 0110h).

Care must be taken to ensure that the `routing_header` bits in a T8207 device are not changed until any previously setup loopback cell has been received and retransmitted. If these bits are changed prematurely, misrouting will occur.

### **10.3.4 Multicast Routing**

The T8207 may be programmed to accept certain multicast data cells using the multicast memories at addresses E0h through FFh (or 0C00h through 0C1Eh) and 0C20h through 0DFEh. The net numbers of accepted multicast control cells are programmed in the memory space E0h through FFh (or 0C00h through 0C1Eh) and 0C20h through 0DFEh. These memory spaces hold 256 bits each. Each bit represents a multicast net number from 0 to 255.

**If the T8207\_sel bit (Table 59) is cleared, the multicast memories at addresses 0D00h to 0DFEh are ignored.**

**Note:** To prevent potential multicast memory errors, these memory spaces should be cleared during the initialization process.

For ATM mode, if the `T8207_sel` bit is cleared, the net numbers of accepted multicast data cells are programmed in the multicast number memories, which are divided among eight PHY ports. If 16 ports are used in this mode, each memory space is shared between two ports, e.g., ports zero and one use the memory assigned to PHY 0, ports two and three use the memory assigned to PHY 1, and so on (see Section 9.2.2, Outgoing ATM Mode (Cells Sent by T8207)).

## 10 Cell Bus Interface (continued)

### 10.3.4 Multicast Routing (continued)

For ATM mode, if the T8207\_sel bit is set, the net numbers of accepted multicast data cells are programmed in the multicast number memories, which are divided among sixteen PHY ports. If 16 ports are used, each port has one memory space. If 32 ports are used, each memory space is shared between two ports, e.g., ports zero and one use the memory assigned to PHY 0, ports two and three use the memory assigned to PHY 1, and so on.

The cell priority bits select the specific queue in the queue group to which the cell is routed. (See Section 11.4, Queuing.) Note that multicast control cells use the same multicast number memory as PHY 0 multicast data cells. See Table 122 in Section 14.3, Extended Memory Registers and Table 52 in Section 14.2, Direct Memory Access Registers, respectively.

For PHY mode, multicast cells are only transmitted to queue group 0, and only the PHY port 0 and control cell multicast direct memory at addresses E0h through FFh (or 0C00h through 0C1Eh) is used. The cell priority determines the specific queue in queue group 0 to which the cell is routed. (See Section 10.3.2, Data Cells.)

### 10.3.5 Broadcast Routing

Broadcast control cells are transmitted and received as described in Section 10.3.1, Control Cells. The broadcast control cell bus routing header has a broadcast control cell header type.

For ATM mode, if the T8207\_sel bit (Table 59) is cleared and 8 PHY ports or less are being used, the broadcast data cells are transmitted to all the ports. If 16 ports are used, the broadcast data cells are transmitted to only 8 of the 16 ports depending on the cell priority bits that select the specific queue.

For ATM mode, if the T8207\_sel bit (Table 59) is set, and 16 PHY ports or less are being used, the broadcast data cells are transmitted to all the ports. If 32 ports are used, the broadcast data cells are transmitted to only 16 of the 32 ports depending on the cell priority bits that select the specific queue.

For PHY mode, if SDRAM is bypassed, broadcast data cells are only transmitted to queue 0. If the SDRAM is **not** bypassed, broadcast data cells are only transmitted to queue group 0, and only PHY port 0 is used (although the device will take the time to try to broadcast data cells to all the ports, cells will not be stored in queue groups other than 0).

## 10.4 Cell Bus Arbitration

One of the T8207 devices sharing the cell bus must be configured as bus arbiter by clearing the cb\_arb\_sel bit in the cell bus configuration/status register (address 0130h) or by pulling the arb\_en\* lead low. Using an arbitration algorithm, the arbiter decides the next device to transmit on the cell bus and issues the grant signals at the end of the cell bus frame. The arbiter also generates the active-low frame synchronization signal that occurs every 16 clock cycles in 16-user mode and every 32 clock cycles in 32-user mode.

To grant transmission requests, the arbiter must analyze requests received during the request section of the current frame for 16-user mode or during two request cycles for 32-user mode. The arbitration algorithm used is round-robin and based on the priority of the request and the last request granted.

The arbiter circuitry in all T8207 devices on the cell bus will synchronize to the active arbiter on the cell bus. So, when an inactive device becomes the arbiter, it will begin sending frame synchronization signals that coincide to the clock cycle that the original arbiter would have sent its next frame synchronization signal. This prevents the new arbiter from misinterpreting random signals on its first request cycle as valid requests.

**10 Cell Bus Interface** (continued)

**10.5 Cell Bus Monitoring**

Every T8207 device monitors the cell bus for proper operation. The monitoring section of the T8207 checks for the presence of the read clock, the write clock, and the frame synchronization signal. The `cb_wc_miss` bit in the main interrupt status 1 register (address 0102h) is set when the write clock is inactive for 32 `mclk` cycles. Likewise, the `cb_rc_miss` bit in the main interrupt status 1 register is set when the read clock is inactive for 32 `mclk` cycles. In addition, the `cb_fs_miss` bit in the main interrupt status 1 register is set when the frame synchronization signal is inactive for greater than 16 cell bus read clock cycles for 16-user mode or for greater than 32 read clock cycles for 32-user mode. This bit is also set when the cell bus write clock is inactive for 32 `mclk` cycles.

When cells arrive from the cell bus, the cell bus monitoring section of the receiving device calculates the bit interleave parity value over the 54-byte field from the first tandem routing header byte through the final payload byte. If this calculated value does not match the value in bits 24 through 31 of the final clock cycle of the frame, the cell is discarded.

The T8207 detects when a device asserts transmission requests and is not granted permission within a programmable time period. The `cb_grnt_to` bit in the main interrupt status 1 register (address 0102h) is set when a device has not been granted permission to transmit within the number of frames programmed in the `cb_req_to` bits of the main configuration 3 register (address 0116h).

**10.6 GTL+ Logic**

For the T8207, the cell bus data, frame sync, and acknowledge signals use onboard GTL+ transceivers, and the cell bus clock signals use onboard GTL+ receivers. The GTL+ bus drivers are open drain and require terminating resistors at both ends of each line. The terminating resistor ( $R$ ) may be from  $40\ \Omega$  to  $50\ \Omega$  and should be pulled up to  $1.5\ V \pm 10\%$  ( $V_{TT}$ ). The actual value of the terminating resistors should be chosen to match the bus line impedance. Figure 17A below illustrates the terminating resistors and the configuration of one GTL+ bus line. The termination resistors are typically placed at the ends of the bus of the backplane.

The signal rise and fall times from the transceivers are carefully controlled to minimize out of band signals without affecting the overall transmission rates. These controlled signal edges, in addition to proper resistive line termination, minimize noise and ringing. The slew rate of the GTL+ buffers can be programmed using bits [2:0] of register 2Eh.

The GTL+ receiver compares its input signal to a voltage reference, `cb_vref`, to determine the logic level of the input. The value of the voltage reference is  $2/3\ V_{TT}$  and is created using the voltage divider shown in Figure 17B. The  $1\ k\Omega$  resistors are 1% because the `cb_vref` voltage must track  $V_{TT}$  by 1%. The  $0.01\ \mu F$  capacitor is a decoupling capacitor on the `cb_vref` input.

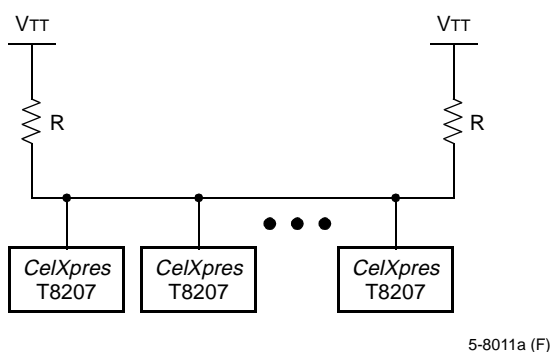

5-8011a (F)

**A. GTL+ Bus with Terminating Resistors**

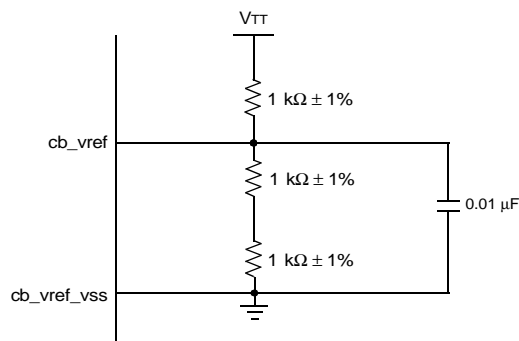

5-8012a(F)

**B. GTL+ Threshold Voltage Reference**

**Figure 17. GTL+ External Circuitry**

## 10 Cell Bus Interface (continued)

### 10.7 Cell Bus Write and Read Clocks

The read and write clocks (cb\_wc\* and cb\_rc\* pins) are supplied from an external source. The write clock should be delayed 1.5 ns to 4 ns relative to the read clock to ensure sufficient data hold time. The position of the clock source relative to the cell bus devices on the card or on connecting cards determines the actual delay that should be used. When the clock source is centrally located among the cell bus devices, a longer delay may be used. When the clock source is at either end of the cell bus devices, a shorter delay is needed. Also, a higher clock frequency requires a shorter delay.

## 11 SDRAM Interface

For outgoing UTOPIA cells, the TX UTOPIA cell buffer supports 64 queues. These queues are separated into 16 queue groups, each consisting of four different priority queues as described in Section 9.2.2, *Outgoing ATM Mode (Cells Sent by T8207)*. This cell buffer holds 128 outgoing cells. Additional buffering is provided by an external SDRAM. Connection to an external SDRAM is selected by clearing the `sdram_bypass` bit in the main configuration 1 register (address 0100h).

If the SDRAM is not used, it is bypassed by setting the `sdram_bypass` bit in the main configuration 1 register at start-up. When bypassed, only queue 0 of the 64 queues in the TX UTOPIA cell buffer is used. The only buffering available in this mode is the 128-cell internal memory (TX PHY FIFO) and up to 128 cells from queue 0 of the TX UTOPIA cell buffer. The TX PHY FIFO overflows only if the TX UTOPIA cell buffer is full, and as a result, the TX PHY FIFO is also full. The setting of the `div_queue` bits in the main configuration 2 register (address 0112h) determines the number of cell locations allocated to queue 0 of the TX UTOPIA cell buffer. Be sure to program these bits to "101" to maximize buffering.

### 11.1 Memory Configuration

The SDRAM interface supports from 2 Mbytes to 32 Mbytes of memory. This memory size is realized using 16 Mbit or 64 Mbit devices. Table 17 below outlines the various memory configurations supported.

**Table 17. Supported Memory Configurations**

Number of Devices	Device Memory Size and Data Bus Organization	Number of Columns	Number of Banks	Number of Rows	Total Memory
1	16 Mbit, 16-bit data bus	256	2	2048	2 Mbyte
2	16 Mbit, 8-bit data bus	512	2	2048	4 Mbyte
4	16 Mbit, 4-bit data bus	1024	2	2048	8 Mbyte
1	64 Mbit, 16-bit data bus	256	4	4096	8 Mbyte
2	64 Mbit, 8-bit data bus	512	4	4096	16 Mbyte
4	64 Mbit, 4-bit data bus	1024	4	4096	32 Mbyte

### 11.2 Powerup Sequence

The powerup sequence for the SDRAM must be performed manually before the SDRAM is enabled. Using the idle state 1 and 2 registers (addresses 0420h and 0422h), the manual access state 1 and 2 registers (addresses 0424h and 0426h), and the `gen_man_acc` bit in the SDRAM control register (address 0400h), follow the powerup command sequence prescribed by the SDRAM manufacturer. The T8207 does not control the chip select, the clock enable, and the DQM inputs to the SDRAM. These signals should be externally tied to the appropriate logic level or external control signal.

To manually execute SDRAM commands, first set up the idle values for CAS\*, RAS\*, WE\*, bank select (BS), and the address signals using the `cas_idle`, `ras_idle`, `we_idle`, `bs_idle[1:0]`, and `addr_idle[11:0]` bits in the idle state 1 and 2 registers. Then manually set up the value of these signals for the first SDRAM command using the `cas_man`, `ras_man`, `we_man`, `bs_man[1:0]`, and `addr_man[11:0]` bits in the manual access state 1 and 2 registers. Finally, write a '1' to the `gen_man_acc` bit in the SDRAM control register. Writing this '1' drives the CAS, RAS, WE\*, BS, and address values (in the manual access state 1 and 2 registers) onto the associated pins, for one SDRAM clock cycle. After the one clock cycle, these signals return to their idle state. Repeat this process, making sure minimum timing between commands is met, until the powerup process has been completed.

In the powerup sequence, configure the mode register of the SDRAM for a burst length of one and a CAS latency of two or three. With a burst length of one, sequential and interleave addressing behave the same, so the SDRAM may be configured for either addressing mode.



## 11 SDRAM Interface (continued)

### 11.3 SDRAM Interface Timing

The mclk clock is the source of the SDRAM clock (sd\_clk) from the T8207. Based on the frequency of the SDRAM clock and the speed grade of the SDRAM, four timing parameters must be programmed into the SDRAM configuration register at address 0408h. These timing parameters are specified in SDRAM (mclk) clock cycles and are listed below:

- RAS inactive to CAS active (ras2cas)—its value may be set from two to four SDRAM clock cycles.
- CAS inactive to precharge command active (cas2pre)—its value may be set from one to four SDRAM clock cycles.
- Precharge command inactive to next command active (pre2cmd)—its value may be set from one to four SDRAM clock cycles.
- CAS before RAS (CBR) refresh command inactive to next CBR refresh command active (ref2cmd)—its value may be set to 3, 7, or 15 SDRAM clock cycles.

Actual values for these parameters are obtained from the data sheet of the SDRAM used. For optimum performance, these parameters should be programmed to the lowest acceptable values. The earliest time that a CAS may be asserted after an RAS may be obtained from the data sheet parameter that describes the minimum time from the activate command to the read/write command. Three parameters affect the earliest time that a precharge command may follow a CAS. For read commands, a precharge command may be issued one clock earlier than the last read data. The actual number of clock cycles depends on the CAS latency needed for the device. For write commands, the earliest time that a precharge command may be issued following a CAS may be obtained from the SDRAM data sheet parameter that describes the minimum time from the last data in to the precharge command. In addition to these two parameters, the minimum time from the activate command to the precharge command may need to be considered to obtain the value for cas2pre. If the SDRAM is only accessed for queuing purposes, 28 consecutive CAS commands will be executed between the activate command and the precharge command, and the minimum time from the activate command to the precharge command does not need to be considered. If the microprocessor reads and writes the SDRAM memory, only one CAS command will be executed between the activate command and the precharge command. In this case, the minimum time from the activate command to the precharge command is significant and must be considered. The minimum time from the precharge command to the next command may be obtained from the data sheet parameter that describes the minimum time from the precharge command to the activate command. The minimum time from the CBR refresh command to the next CBR refresh command may be obtained from the data sheet. In the T8207, the minimum time from CBR refresh to any other command is 15 SDRAM clock cycles. In the data sheet, the parameters may be specified in actual time units rather than clock cycles. To determine the number of clock cycles, divide the parameter value by the SDRAM clock period. Figure 18 below illustrates these timing parameters and the number of clock cycles needed to read or write a cell using the default values for the parameters.

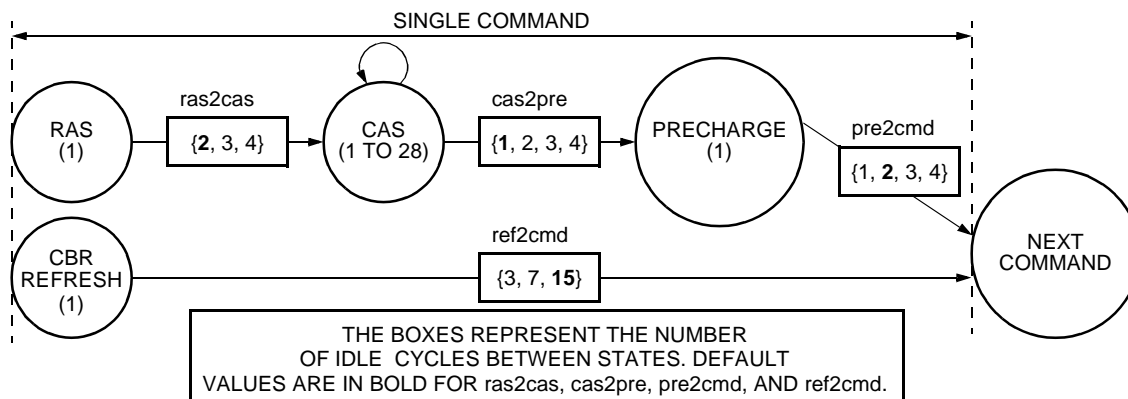

Figure 18. SDRAM Timing Parameters

## 11 SDRAM Interface (continued)

### 11.4 Queuing

Queuing is different for a T8207 device with its T8207\_sel (Table 59) bit set than a T8207 device with its T8207\_sel bit cleared.

For a device configured in ATM mode with its T8207\_sel bit set, up to 16 groups of queues with four priorities per group may be configured in the SDRAM for a total of 64 queues. Therefore, the four port group address bits point to one of 16 queue groups, and the two priority bits point to one of four queues in the group. (For a description of the port group address and priority bits, see Section 10.3.2, Data Cells.) Priority bits with a value of zero represent the highest priority, and those with a value of three, the lowest priority.

If the ATM is configured to support eight or less PHY ports, each port is mapped to one queue group using the port\_rte[31:0] bits in the TX PHY FIFO routing 0 and 1 registers (addresses 017Ch and 017Eh). For example, for a configuration of eight PHY ports, which includes ports 0, 2, 4, 6, 8, 10, 12, and 14, PHY port 0 is assigned queue group zero or queues zero, one, two, and three. Likewise, PHY port 2 is assigned group one or queues four, five, six, and seven, and so on.

An ATM configured to support 16 PHY ports is a special case. When the T8207\_sel bit is set and the ATM is configured to support 16 PHY ports, each port (0—15) is assigned to its associated queue group as illustrated in Table 18, regardless of the value of the port\_rte[63:0] bits. In this case, port 0 is assigned to queue group 0, port 1 to queue group 1, and so on.

For an ATM configured to support 32 PHY ports, each queue group is shared between two ports as specified in Section 9.2.2, Outgoing ATM Mode (Cells Sent by T8207), and the four queues may be split in any way between the two ports using the port\_rte[63:0] bits. Table 19 illustrates the relationship between the queue organization and the port group address/priority bits for a device configured to support 32 PHY ports and whose port\_rte[63:0] bits are programmed to the **normal** 32-port mode as described in Section 9.2.2, Outgoing ATM Mode (Cells Sent by T8207). See the TX PHY FIFO routing 3, 2, 0, and 1 registers at addresses 0178h, 017Ah, 017Ch, and 017Eh.

When the T8207\_sel bit is cleared, 32 PHY ports are not supported. In this mode, eight or less PHY ports are each mapped to one queue group using the port\_rte[31:0] bits in the TX PHY FIFO routing 0 and 1 registers. For 16 PHY ports, each queue group is shared between two ports, and the four queues may be split in any way between the two ports using the port\_rte[31:0] bits. Table 20 illustrates the relationship between the queue organization and the port address/priority bits for a device configured to support 16 PHY ports and whose port\_rte[31:0] bits are programmed to the **normal** 16-port mode as described in Section 9.2.2, Outgoing ATM Mode (Cells Sent by T8207). See the TX PHY FIFO routing 0 and 1 registers at addresses 017Ch and 017Eh.

**11 SDRAM Interface** (continued)

**Table 18. Queue Organization and Port Group Address/Priority Bits for 16 Ports with T8207\_sel = 1**

Port Number	Queue Group	Queue Number	Priority	Port Group Address Bits	Priority Bits
0	0	0	Highest	"0000"	"00"
0	0	1	High	"0000"	"01"
0	0	2	Low	"0000"	"10"
0	0	3	Lowest	"0000"	"11"
1	1	4	Highest	"0001"	"00"
1	1	5	High	"0001"	"01"
1	1	6	Low	"0001"	"10"
1	1	7	Lowest	"0001"	"11"
2	2	8	Highest	"0010"	"00"
2	2	9	High	"0010"	"01"
2	2	10	Low	"0010"	"10"
2	2	11	Lowest	"0010"	"11"
3	3	12	Highest	"0011"	"00"
3	3	13	High	"0011"	"01"
3	3	14	Low	"0011"	"10"
3	3	15	Lowest	"0011"	"11"
4	4	16	Highest	"0100"	"00"
4	4	17	High	"0100"	"01"
4	4	18	Low	"0100"	"10"
4	4	19	Lowest	"0100"	"11"
5	5	20	Highest	"0101"	"00"
5	5	21	High	"0101"	"01"
5	5	22	Low	"0101"	"10"
5	5	23	Lowest	"0101"	"11"
6	6	24	Highest	"0110"	"00"
6	6	25	High	"0110"	"01"
6	6	26	Low	"0110"	"10"
6	6	27	Lowest	"0110"	"11"
7	7	28	Highest	"0111"	"00"
7	7	29	High	"0111"	"01"
7	7	30	Low	"0111"	"10"
7	7	31	Lowest	"0111"	"11"
8	8	32	Highest	"1000"	"00"
8	8	33	High	"1000"	"01"
8	8	34	Low	"1000"	"10"
8	8	35	Lowest	"1000"	"11"
9	9	36	Highest	"1001"	"00"
9	9	37	High	"1001"	"01"
9	9	38	Low	"1001"	"10"
9	9	39	Lowest	"1001"	"11"

**11 SDRAM Interface** (continued)

**Table 18. Queue Organization and Port Group Address/Priority Bits for 16 Ports with T8207\_sel = 1**  
 (continued)

Port Number	Queue Group	Queue Number	Priority	Port Group Address Bits	Priority Bits
10	10	40	Highest	"1010"	"00"
10	10	41	High	"1010"	"01"
10	10	42	Low	"1010"	"10"
10	10	43	Lowest	"1010"	"11"
11	11	44	Highest	"1011"	"00"
11	11	45	High	"1011"	"01"
11	11	46	Low	"1011"	"10"
11	11	47	Lowest	"1011"	"11"
12	12	48	Highest	"1100"	"00"
12	12	49	High	"1100"	"01"
12	12	50	Low	"1100"	"10"
12	12	51	Lowest	"1100"	"11"
13	13	52	Highest	"1101"	"00"
13	13	53	High	"1101"	"01"
13	13	54	Low	"1101"	"10"
13	13	55	Lowest	"1101"	"11"
14	14	56	Highest	"1110"	"00"
14	14	57	High	"1110"	"01"
14	14	58	Low	"1110"	"10"
14	14	59	Lowest	"1110"	"11"
15	15	60	Highest	"1111"	"00"
15	15	61	High	"1111"	"01"
15	15	62	Low	"1111"	"10"
15	15	63	Lowest	"1111"	"11"

**11 SDRAM Interface** (continued)

**Table 19. Queue Organization and Port Group Address/Priority Bits for 32 Ports**

Port Number	Queue Group	Queue Number	Priority	Port Group Address Bits	Priority Bits
0	0	0	High	"0000"	"00"
0	0	2	Low	"0000"	"10"
1	0	1	High	"0000"	"01"
1	0	3	Low	"0000"	"11"
2	1	4	High	"0001"	"00"
2	1	6	Low	"0001"	"10"
3	1	5	High	"0001"	"01"
3	1	7	Low	"0001"	"11"
4	2	8	High	"0010"	"00"
4	2	10	Low	"0010"	"10"
5	2	9	High	"0010"	"01"
5	2	11	Low	"0010"	"11"
6	3	12	High	"0011"	"00"
6	3	14	Low	"0011"	"10"
7	3	13	High	"0011"	"01"
7	3	15	Low	"0011"	"11"
8	4	16	High	"0100"	"00"
8	4	18	Low	"0100"	"10"
9	4	17	High	"0100"	"01"
9	4	19	Low	"0100"	"11"
10	5	20	High	"0101"	"00"
10	5	22	Low	"0101"	"10"
11	5	21	High	"0101"	"01"
11	5	23	Low	"0101"	"11"
12	6	24	High	"0110"	"00"
12	6	26	Low	"0110"	"10"
13	6	25	High	"0110"	"01"
13	6	27	Low	"0110"	"11"
14	7	28	High	"0111"	"00"
14	7	30	Low	"0111"	"10"
15	7	29	High	"0111"	"01"
15	7	31	Low	"0111"	"11"
16	8	32	High	"1000"	"00"
16	8	34	Low	"1000"	"10"
17	8	33	High	"1000"	"01"
17	8	35	Low	"1000"	"11"
18	9	36	High	"1001"	"00"
18	9	38	Low	"1001"	"10"
19	9	37	High	"1001"	"01"
19	9	39	Low	"1001"	"11"
20	10	40	High	"1010"	"00"
20	10	42	Low	"1010"	"10"

**11 SDRAM Interface** (continued)

**Table 19. Queue Organization and Port Group Address/Priority Bits for 32 Ports** (continued)

Port Number	Queue Group	Queue Number	Priority	Port Group Address Bits	Priority Bits
21	10	41	High	"1010"	"01"
21	10	43	Low	"1010"	"11"
22	11	44	High	"1011"	"00"
22	11	46	Low	"1011"	"10"
23	11	45	High	"1011"	"01"
23	11	47	Low	"1011"	"11"
24	12	48	High	"1100"	"00"
24	12	50	Low	"1100"	"10"
25	12	49	High	"1100"	"01"
25	12	51	Low	"1100"	"11"
26	13	52	High	"1101"	"00"
26	13	54	Low	"1101"	"10"
27	13	53	High	"1101"	"01"
27	13	55	Low	"1101"	"11"
28	14	56	High	"1110"	"00"
28	14	58	Low	"1110"	"10"
29	14	57	High	"1110"	"01"
29	14	59	Low	"1110"	"11"
30	15	60	High	"1111"	"00"
30	15	62	Low	"1111"	"10"
31	15	61	High	"1111"	"01"
31	15	63	Low	"1111"	"11"

11 SDRAM Interface (continued)

Table 20. Queue Organization and Port Group Address/Priority Bits for 16 Ports with T8207\_sel = 0

Port Number	Queue Group	Queue Number	Priority	Port Group Address Bits	Priority Bits
0	0	0	High	"000"	"00"
0	0	2	Low	"000"	"10"
1	0	1	High	"000"	"01"
1	0	3	Low	"000"	"11"
2	1	4	High	"001"	"00"
2	1	6	Low	"001"	"10"
3	1	5	High	"001"	"01"
3	1	7	Low	"001"	"11"
4	2	8	High	"010"	"00"
4	2	10	Low	"010"	"10"
5	2	9	High	"010"	"01"
5	2	11	Low	"010"	"11"
6	3	12	High	"011"	"00"
6	3	14	Low	"011"	"10"
7	3	13	High	"011"	"01"
7	3	15	Low	"011"	"11"
8	4	16	High	"100"	"00"
8	4	18	Low	"100"	"10"
9	4	17	High	"100"	"01"
9	4	19	Low	"100"	"11"
10	5	20	High	"101"	"00"
10	5	22	Low	"101"	"10"
11	5	21	High	"101"	"01"
11	5	23	Low	"101"	"11"
12	6	24	High	"110"	"00"
12	6	26	Low	"110"	"10"
13	6	25	High	"110"	"01"
13	6	27	Low	"110"	"11"
14	7	28	High	"111"	"00"
14	7	30	Low	"111"	"10"
15	7	29	High	"111"	"01"
15	7	31	Low	"111"	"11"

## **11 SDRAM Interface** (continued)

Of the four priority queues, the highest-priority (priority zero), lowest-delay queue may be used for constant bit rate (CBR) traffic. The other three queues, in descending order of priority, may be used for variable bit rate (VBR), available bit rate (ABR), and unspecified bit rate (UBR) traffic, respectively. Generally, as the priority becomes lower, the queues become larger because lower-priority cells are likely to accumulate while higher-priority cells are transmitted.

The size and location of each queue is programmable using the `base_addressX[24:6]` and `end_addrX[24:6]` bits in the Queue X Definition Structure shown in Table 119. Using these base and end address registers, the size of each queue may be programmed to a minimum of four cells and up to a maximum of 512K cells in one-cell increments.

Each queue must be disabled during queue configuration by clearing the `queueX_rd_en` and `queueX_wr_en` bits in the queue X registers (addresses 0440h through 04BEh) (Table 118).

Cells sent to write-disabled queues will be discarded. Cells sent to read-disabled queues will be written into the SDRAM but never transmitted to the TX UTOPIA port. Read-disabled queues may be used, as large external memory, to store cells bound for the microprocessor. The microprocessor may use as many queues as required for different type cells. Because the microprocessor reads only 2 bytes from the SDRAM per access, the `cas2pre` value (see Section 11.3, SDRAM Interface Timing) may need to be larger than that required for the transferring of cells only. Therefore, to maximize the bandwidth of the SDRAM for cell bus to UTOPIA traffic, restrict microprocessor access of the SDRAM to the initialization function (e.g., downloading microcode over the cell bus).

When the microprocessor increments the read pointer to read the SDRAM, it must first write the three least significant bits (`rd_pntX[8:6]`) of the read pointer for the appropriate queue followed by the 16 most significant bits (`rd_pntX[24:9]`). This order must be followed for proper operation. All queues used for microprocessor cell reception must be at least 32 cells long. (See the Queue X Definition Structure, Table 119, for more information on these bits.)

### **11.5 SDRAM Refresh**

The T8207 SDRAM interface performs CAS before RAS (CBR) refresh commands at a rate programmed in the `ref_cnt` bits of the refresh register (address 0410h). The value in the refresh register represents refresh cycles in SDRAM clock cycles. One refresh command is executed every `ref_cnt` clock cycles, on average, when the SDRAM is idle. In addition, the value programmed in the refresh lateness register (address 0412h) represents the maximum time, in programmed refresh cycles, between actual refresh cycles. If this limit is exceeded, the `ref_late` bit in the SDRAM interrupt status register (address 0402h) will be set, and if the `ref_late` interrupt is enabled, an interrupt will be generated. The `ref_late` indication is provided for diagnostic purposes and does not necessarily indicate a fatal error. Bit errors in the actual cell are reported in the `crc8_err_even` and `crc8_err_odd` bits of the SDRAM interrupt status register.



## 11 SDRAM Interface (continued)

### 11.6 SDRAM Throughput

The SDRAM clock frequency must be fast enough for cell transfers, to and from the SDRAM, to occur without overruns to the TX PHY FIFO or underruns to the TX UTOPIA cell buffer. Using the default values for *ras2cas*, *cas2pre*, and *pre2cmd*, thirty-five clock cycles are required to transfer one cell (56 bytes) into or out of the SDRAM. The assumed efficiency rate is 90%. Therefore, the number of cells per second that can be read or written into the SDRAM is calculated using the following equation:

$$\text{Cell Rate} = (f_{\text{mclk}}/35 \text{ cycles per cell} \times 90\%)$$

where  $f_{\text{mclk}}$  is the frequency of the SDRAM clock.

The maximum UTOPIA and cell bus bandwidths must be calculated to ensure that the SDRAM clock frequency supports these bandwidths. For example, assume that the total bandwidth on the UTOPIA bus is 64 Mbits/s and that the cell bus clock rate is 33 MHz. The maximum number of cells per second that the cell bus can send is:

$$\frac{33 \text{ MHz}}{16 \text{ cycles per cell}} = 2.06 \text{ Mcells per second.}$$

On the UTOPIA port, the total number of cells that can be sent is:

$$\frac{64 \text{ Mbits/s}}{53 \text{ bytes per cell} \times 8 \text{ bits per byte}} = 151 \text{ Kcells per second.}$$

Thus, the total number of cells per second from the cell bus and to the UTOPIA bus is 2.21 Mcells per second. For the cell rate equation above, the required SDRAM clock frequency is:

$$\frac{2.21 \text{ Mcells per second}}{0.9} * 35 \text{ cycles per cell} = 86 \text{ MHz.}$$

This is a worst-case example and assumes that all potential cells on the cell bus are going to this one device. The SDRAM frequency calculation produces a lower frequency if the actual system characteristics are considered and if the distribution of cells is controlled.

## **12 Traffic Management**

### **12.1 Cell Loss Priority (CLP)**

To avoid congestion, cells with their CLP bit set may be automatically discarded upon reception at the TX PHY FIFO or upon reception at a queue in the SDRAM. The cells are discarded if the TX PHY FIFO or SDRAM queue is filled beyond the programmed limit and this feature is enabled.

For the TX PHY FIFO, this limit is programmed in the `clp_fill_limit` bits of the main configuration/control register (address 0110h). The feature is enabled when the `cell_drop_en` bit in the main configuration/control register (address 0110h) is set.

For the SDRAM queues, this limit is programmed for each queue (X) in the `clp_fillX[24:9]` and `clp_fillX[8:6]` bits in Table 119. The feature is enabled when the `queueX_clp_en` bit in the queue X registers (address 0440h through 04BEh) is set. When a received cell exceeds the CLP fill level for a queue, the T8207 sets the corresponding `queueX_clp_lim` status bit in the queue X registers. If the fill level is set to zero, the corresponding `queueX_clp_lim` bit is set by the first received cell for the queue. Any fill greater than zero has an inherent inaccuracy of seven cells; therefore, a fill limit of eight or less is not meaningful. The number of cells in each queue may be determined by reading the value of the read and write pointers for the specific queue.

### **12.2 Forward Explicit Congestion Notification (FECN)**

The T8207 supports FECN for data cells using the explicit forward congestion indication (EFCI) bit in the cell header PTI. If enabled, FECN indicates cells that have encountered congestion by setting their EFCI bit. The T8207 sets the EFCI bit in cells that leave a queue that is filled beyond the limit programmed in the `fecn_fillX[24:9]` and `fecn_fillX[8:6]` bits in Table 119. (See Figure 12.) The T8207 only sets the EFCI bit in cells when the function is enabled by the `queueX_fecn_en` bit in the queue X registers (address 0440h through 04BEh). When a received cell exceeds the FECN fill level for a queue, the T8207 sets the corresponding `queueX_fecn_lim` status bit in the queue X registers. If the fill level is set to zero, the corresponding `queueX_fecn_lim` bit is set by the first received cell for the queue. Any fill greater than zero has an inherent inaccuracy of seven cells; therefore, a fill limit of eight or less is not meaningful. The number of cells in each queue may be determined by reading the value of the read and write pointers for the specific queue.

### **12.3 Partial Packet Discard (PPD)**

Partial packet discard (PPD) is accomplished through the cooperation of the T8207 (source) that places the cell on the cell bus and the T8207 (destination) that receives the cell from the bus. The source T8207 uses its translation RAM to place a unique ID (PPD pointer) and PPD enable bit in the cell for each AAL5 connection. The PPD pointer and PPD enable bit may consist of any bit in the first 64 bits of the bus cell (cell bus routing header, tandem routing header, and ATM cell header) and are created at connection establishment.

The destination T8207 uses the PPD state memory (address 1000h to 13FEh) to track the state of AAL5 virtual channels for partial packet discard. Each bit in the memory represents one of 8192 potential AAL5 virtual channels. When the virtual channel connection is initially established, the bit in PPD state memory pointed to by the PPD pointer is cleared. When a cell that has its PPD enabled is discarded, the bit pointed to by the PPD pointer becomes set. Once this bit is set, successive cells with the same PPD pointer will be discarded until the last cell is received. The last cell is identified using the SDU-type bit in the PTI of the cell header. When the last cell of the packet is received, the virtual channel's corresponding bit in the PPD state memory is automatically cleared, and the last cell is transmitted.

The `ppd_en_sel[5:0]` bits in the PPD information 1 register specify which of the bus cell's first 64 bits (cell bus routing header, tandem routing header, and ATM cell header) enable PPD. PPD is enabled when the associated bit in the headers is one. The partial packet discard bits specify which of the bus cell's first 64 bits are used to create the PPD pointer. These pointer bits are `ppd_pnt0_sel[5:0]` through `ppd_pnt12_sel[5:0]` in the PPD information 1 through 7 registers (addresses 0206h through 0212h). When an AAL5 virtual channel connection is initially established, its PPD bit in the PPD state memory must be cleared using the `write_pul`, `write_val`, and `write_addr` bits in the PPD memory write register at address 0418h.

## 13 JTAG Test Access Port

A 5-pin test access port, consisting of the `jtag_tclk`, `jtag_tms`, `jtag_tdi`, `jtag_tdo`, and `jtag_trst` signals, provides the standard interface to the test logic. The `jtag_trst` signal is active-low and resets the JTAG circuitry. When `jtag_trst` is high, the JTAG interface is enabled. If the JTAG port is not used, `jtag_trst` should be tied low.

JTAG may be used only to test the inputs, outputs, and their connection to the printed-wiring board. In JTAG, serial bit patterns are shifted into the device through the `jtag_tdi` pin, and the results can be observed at the I/O and at the corresponding JTAG serial output, `jtag_tdo`. Since this JTAG conforms to the JTAG standard, the `jtag_tdi` and `jtag_tdo` may be linked to the JTAG port of other devices for systemic testing. The boundary-scan description language may be found on the Agere website.

### 13.1 Instruction Register

The instruction register (IR) is 3 bits in length. The instructions are defined in Table 21.

**Table 21. Instruction Register**

Instruction	Binary Code	Description
EXTEST	"000"	Places the boundary-scan register in extest mode.
SAMPLE	"001"	Places the boundary-scan register in sample mode.
Reserved	"010"—"110"	Reserved.
BYPASS	"111"	Places the bypass register in the scan chain.

### 13 JTAG Test Access Port (continued)

#### 13.2 Boundary-Scan Register

The boundary-scan register (BSR) is 222 bits in length. Table 22 gives descriptions of each cell in the boundary-scan chain beginning with the least significant bit.

**Table 22. Boundary-Scan Register Descriptions**

Boundary-Scan Register Bit	Name	Pin Name	Description
0—4	UA_N(0:4)	ua*[0:4]	Input.
5	ENARB_OE	—	ENARB is an input when ENARB_OE = 0.
6	ENARB	arb_enb*	Bidirectional.
7	CKOE_IN	—	CKO is high impedance when CKOE_IN = 0.
8	CKO	cko	3-statable output.
9	CKOE	cko_e	Input.
10	GPIO_OE(0)	—	GPIO(0) is an input when GPIO_OE(0) = 0.
11	GPIO(0)	gpio[0]	Bidirectional.
12	GPIO_OE(1)	—	GPIO(1) is an input when GPIO_OE(1) = 0.
13	GPIO(1)	gpio[1]	Bidirectional.
14	GPIO_OE(2)	—	GPIO(2) is an input when GPIO_OE(2) = 0.
15	GPIO(2)	gpio[2]	Bidirectional.
16	GPIO_OE(3)	—	GPIO(3) is an input when GPIO_OE(3) = 0.
17	GPIO(3)	gpio[3]	Bidirectional.
18	GPIO_OE(4)	—	GPIO(4) is an input when GPIO_OE(4) = 0.
19	GPIO(4)	gpio[4]	Bidirectional.
20	GPIO_OE(5)	—	GPIO(5) is an input when GPIO_OE(5) = 0.
21	GPIO(5)	gpio[5]	Bidirectional.
22	GPIO_OE(6)	—	GPIO(6) is an input when GPIO_OE(6) = 0.
23	GPIO(6)	gpio[6]	Bidirectional.
24	GPIO_OE(7)	—	GPIO(7) is an input when GPIO_OE(7) = 0.
25	GPIO(7)	gpio[7]	Bidirectional.
26	MUX	mux	Input.
27	RESET_N	reset*	Input.
28	CB_ACK_N	cb_ack*	Bidirectional.
29—60	CB_D_N(0:31)	cb_d*[0:31]	Bidirectional.
61	CB_F_N	cb_fs*	Bidirectional.
62	CB_DISBL	cb_disable*	Input.
63	CB_RC_N	cb_rc*	Input.
64	CB_WC_N	cb_wc*	Input.
65—72	A(0:7)	a[0]/ale, a[1:7]	Input.
73	D_OE	—	D(0:7) are inputs when D_OE = 0.
74—81	D(0:7)	d[0:7]	Bidirectional.
82	MOTO	mot_sel	Input.
83	RD_WR_N	rd*_rw*	Input.

### 13 JTAG Test Access Port (continued)

Table 22. Boundary-Scan Register Descriptions (continued)

Boundary-Scan Register Bit	Name	Pin Name	Description
84	RDY_DTACK_N_OE	—	RDYDTACK is high impedance when RDY_DTACK_N_OE = 0.
85	RDYDTACK	rdy_dtack*	3-statable output.
86	SEL_N	sel*	Input.
87	WR_N	wr*_ds*	Input.
88	DEVHIZ_N_HIGH_DRIVE	—	INT_IRQ, SD_A(11:0), SD_BS(1:0), SD_CAS_N, SD_RAS_N, and SD_WE_N are high impedance when DEVHIZ_N_HIGH_DRIVE = 0.
89	INT_IRQ	int_irq*	3-statable output.
90—101	SD_A(0:11)	sd_a[0:11]	3-statable output.
102—103	SD_BS(0:1)	sd_bs[0:1]	3-statable output.
104	SD_CAS_N	sd_cas*	3-statable output.
105	SD_CLK_OE	—	SD_CLK is an input when SD_CLK_OE = 0.
106	SD_CLK	sd_clk	Bidirectional.
107	SD_D_OE	—	SD_D(15:0) are inputs when SD_D_OE = 0.
108—123	SD_D(0:15)	sd_d[0:15]	Bidirectional.
124	SD_RAS_N	sd_ras*	3-statable output.
125	SD_WE_N	sd_we*	3-statable output.
126	TR_CONT_OE	—	TR_OE_N, TR_WE_N, TR_A(17:0), and TR_CS(1:0) are high impedance when TR_CONT_OE = 0.
127	TR_OE_N	tr_oe*	3-statable output.
128	TR_WE_N	tr_we*	3-statable output.
129—146	TR_A(0:17)	tr_a[0:17]	3-statable output.
147—148	TR_CS(0:1)	tr_cs*[0:1]	3-statable output.
149	TR_D_OE	—	TR_D(7:0) are inputs when TR_D_OE = 0.
150—157	TR_D(0:7)	tr_d[0:7]	Bidirectional.
158	U_RXADDR_OE	—	U_RXADD(4:0) are inputs when U_RXADDR_OE = 0.
159—163	U_RXADD(0:4)	u_rxaddr[0:4]	Bidirectional.
164	U_RXCLAV0_OE	—	U_RXCLV0 is an input when U_RXCLAV0_OE = 0.
165	U_RXCLV0	u_rxclav[0]	Bidirectional.
166—168	U_RXCLV1—U_RXCLV3	u_rxclav[1:3]	Input.
169	U_RXCLK_OE	—	U_RXCLK is an input when U_RXCLK_OE = 0.
170	U_RXCLK	T1	Bidirectional.
171—178	U_RXDAT(0:7)	u_rxdata[0:7]	Input.
179	U_RXENB0_OE	—	U_RXENB(0) is an input when U_RXENB0_OE = 0.

### 13 JTAG Test Access Port (continued)

Table 22. Boundary-Scan Register Descriptions (continued)

Boundary-Scan Register Bit	Name	Pin Name	Description
180	U_RXENB(0)	u_rxenb*[0]	Bidirectional.
181	U_RXENB_OE	—	U_RXENB(3:1) are inputs when U_RXENB_OE = 0.
182—184	U_RXENB(1) – U_RXENB(3)	u_rxenb*[1:3]	Bidirectional.
185	U_RXPRTY	u_rxprty	Input.
186	U_RXSOC	u_rxsoc	Input.
187	U_SHR_I	u_shr_i	Input.
188	U_SHR_O_OE	—	U_SHR_O is an input when U_SHR_O_OE = 0.
189	U_SHR_O	u_shr_o	Bidirectional.
190	U_TXADDR_OE	—	U_TXADD(4:0) are inputs when U_TXADDR_OE = 0.
191—195	U_TXADD(0:4)	u_txaddr[0:4]	Bidirectional.
196	U_TXCLAV0_OE	—	U_TXCLV0 is an input when U_TXCLAV0_OE = 0.
197	U_TXCLV0	u_txclav[0]	Bidirectional.
198—200	U_TXCLV1 – U_TXCLV3	u_txclav[1:3]	Input.
201	U_TXCLK_OE	—	U_TXCLK is an input when U_TXCLK_OE = 0.
202	U_TXCLK	u_txclk	Bidirectional.
203	U_TXDATA_OE	—	U_TXDAT(7:0) are high impedance when U_TXDATA_OE = 0.
204—211	U_TXDAT(0:7)	u_txdata[0:7]	3-stable output.
212	U_TXENB0_OE	—	U_TXENB0 is an input when U_TXENB0_OE = 0.
213	U_TXENB0	u_txenb*[0]	Bidirectional.
214	U_TXENB_OE	—	U_TXENB1, U_TXENB2, and U_TXENB3 are high impedance when U_TXENB_OE = 0.
215—217	U_TXENB1 – U_TXENB3	u_txenb*[1:3]	3-stable output.
218	U_TXPRTY_OE	—	U_TXPRTY is an input when U_TXPRTY_OE = 0.
219	U_TXPRTY	u_txprty	Bidirectional.
220	U_TXSOC_OE	—	U_TXSOC is high impedance when U_TXSOC_OE = 0.
221	U_TXSOC	u_txsoc	3-stable output.

## 14 Registers

The T8207 has two distinct memory spaces, which are the direct memory access registers and the extended memory registers. The direct memory access registers are directly addressed 8-bit (byte) registers and are mapped between addresses 00h and FFh. The extended memory registers are indirectly addressed and mapped between addresses 0100h and 3FFFFFFEh. The extended memory registers are mapped into three major blocks: the main registers, the UTOPIA registers, and the SDRAM registers. They contain the SDRAM memory, the translation RAM, internal memories, and the device's configuration, status, and control registers. Extended memory registers are 16 bits wide. All accesses to the extended memory registers are executed internally as 16 bits. Direct memory access registers are located in Section 14.2, Direct Memory Access Registers, and extended memory registers are located in Section 14.3, Extended Memory Registers.

### 14.1 Register Types

- Read/Write (RW):** These registers may be written or read.
- Read Only (RO):** These registers may only be read.
- Read-Only Latch (ROL):** The read-only latch is used for interrupt status registers. Reading a read-only latch register has no effect on the contents. To clear a bit set in an ROL register, a one must be written to the bit. Writing a zero to the bit has no effect. If the corresponding interrupt enable bit is set, an interrupt will be continuously generated until the bit in the ROL register is cleared.
- Write Only (WO):** These registers may only be written. The write-only registers in the T8207 are a pulse type. When they are written to one, they generate a pulse internally for one clock cycle and then return to zero.

**Table 23. Register Map**

Register Name	Address (h)	Reference Page
Direct Configuration/Control Register (DCCR)	28h	83
Interrupt Service Request (ISREQ)	29h	84
mclk PLL Configuration 0 (MPLLCF0)	2Ah	84
mclk PLL Configuration 1 (MPLLCF1)	2Bh	85
GTL+ Slew Rate Configuration (GTLSRCF)	2Eh	85
GTL+ Control (GTLCTRL)	2Fh	85
Extended Memory Address 1 (Little Endian) (EMA1_LE)	30h	86
Extended Memory Address 2 (Little Endian) (EMA2_LE)	31h	86
Extended Memory Address 3 (Little Endian) (EMA3_LE)	32h	86
Extended Memory Address 4 (Little Endian) (EMA4_LE)	33h	86
Extended Memory Access (Little Endian) (EMA_LE)	34h	86
Extended Memory Data Low (Little Endian) (EMDL_LE)	36h	87
Extended Memory Data High (Little Endian) (EMDH_LE)	37h	87
Extended Memory Address 4 (Big Endian) (EMA4_BE)	30h	88
Extended Memory Address 3 (Big Endian) (EMA3_BE)	31h	88
Extended Memory Address 2 (Big Endian) (EMA2_BE)	32h	88
Extended Memory Address 1 (Big Endian) (EMA1_BE)	33h	88
Extended Memory Access (Big Endian) (EMA_BE)	34h	89
Extended Memory Data High (Big Endian) (EMDH_BE)	36h	89
Extended Memory Data Low (Big Endian) (EMDL_BE)	37h	89
GPIO Output Enable (GPIO_OE)	39h	90
GPIO Output Value (GPIO_OV)	3Bh	90

**14 Registers** (continued)

**Table 23. Register Map** (continued)

<b>Register Name</b>	<b>Address (h)</b>	<b>Reference Page</b>
GPIO Input Value (GPIO_IV)	3Dh	90
Control Cell Receive Direct Memory (CCRXDM)	60h to 93h	91
Control Cell Transmit Direct Memory (CCTXDM)	A0h to D7h	91
PHY Port 0 and Control Cells Multicast Direct Memory (PP0MDM)	E0h to FFh	92
Main Configuration 1 (MCF1)	0100h	93
Main Interrupt Status 1 (MIS1)	0102h	94
Main Interrupt Enable 1 (MIE1)	0104h	95
TX UTOPIA Clock Configuration (TXUCCF)	010Ch	96
RX UTOPIA Clock Configuration (RXUCCF)	010Eh	97
Main Configuration/Control (MCFCT)	0110h	98
Main Configuration 2 (MCF2)	0112h	99
UTOPIA Configuration (UCF)	0114h	100
Main Configuration 3 (MCF3)	0116h	100
Loopback (LB)	0118h	101
UTOPIA Configuration 3 (UCF3)	011Ah	101
UTOPIA Configuration 2 (UCF2)	011Ch	101
Extended LUT Configuration (ELUTCF)	011Eh	101
Extended LUT Control (ELUTCN)	0120h	102
Cell Bus Configuration/Status (CBCFS)	0130h	103
Main Interrupt Status 2 (MIS2)	0132h	103
Main Interrupt Enable 2 (MIE2)	0134h	104
Misrouted LUT 1 (MLUT1)	0142h	105
Misrouted LUT 2 (MLUT2)	0144h	105
Misrouted Cell Header High (MCHH)	0146h	105
Misrouted Cell Header Low (MCHL)	0148h	105
Master Queue 3 (MQ3)	0158h	108
Master Queue 2 (MQ2)	015Ah	108
Master Queue 0 (MQ0)	015Ch	109
Master Queue 1 (MQ1)	015Eh	109
Slave Queue 0 (SQ0)	016Ch	110
Slave Queue 1 (SQ1)	016Eh	110
TX PHY FIFO Routing 3 (TXPFR3)	0178h	111
TX PHY FIFO Routing 2 (TXPFR2)	017Ah	112
TX PHY FIFO Routing 0 (TXPFR0)	017Ch	113
TX PHY FIFO Routing 1 (TXPFR1)	017Eh	114
Routing Information 1 (RI1)	0200h	115
Routing Information 2 (RI2)	0202h	116
Routing Information 3 (RI3)	0204h	117
PPD Information 1 (PPDI1)	0206h	118
PPD Information 2 (PPDI2)	0208h	119
PPD Information 3 (PPDI3)	020Ah	120
PPD Information 4 (PPDI4)	020Ch	121
PPD Information 5 (PPDI5)	020Eh	122



## 14 Registers (continued)

Table 23. Register Map (continued)

Register Name	Address (h)	Reference Page
PPD Information 6 (PPDI6)	0210h	123
PPD Information 7 (PPDI7)	0212h	124
PPD Memory Write (PPDMW)	0418h	124
HEC Interrupt Status 1 (HIS1)	0302h	106
HEC Interrupt Enable 1 (HIE1)	0304h	106
HEC Interrupt Status (HIS)	0306h	106
HEC Interrupt Enable (HIE)	0308h	106
LUT Interrupt Service Request (LUTISR)	030Eh	106
LUT X Configuration/Status (LUTXCFS)	0320h to 033Eh	107
SDRAM Control (SCT)	0400h	128
SDRAM Interrupt Status (SIS)	0402h	128
SDRAM Interrupt Enable (SIE)	0404h	128
SDRAM Configuration (SCF)	0408h	129
Refresh (RFRSH)	0410h	130
Refresh Lateness (RFRSHL)	0412h	130
Idle State 1 (IS1)	0420h	130
Idle State 2 (IS2)	0422h	130
Manual Access State 1 (MAS1)	0424h	131
Manual Access State 2 (MAS2)	0426h	131
SDRAM Interrupt Service Request 4 (SISR4)	0438h	132
SDRAM Interrupt Service Request 3 (SISR3)	043Ah	132
SDRAM Interrupt Service Request 1 (SISR1)	043Ch	132
SDRAM Interrupt Service Request 2 (SISR2)	043Eh	132
Queue X (QX)	0440h to 04BEh	133
PHY Port X Transmit Count Structure (PPTXCNT)	0600h to 067Ch	125
PHY Port X Receive Count Structure (PPRXCNT)	0700h to 07F8h	126
LUT X Configuration 1 Structure (LUTXCF1)	0704h to 077Ch	127
Control Cell Receive Extended Memory (CCRXEM) 0	0800h to 0832h	137
Control Cell Transmit Extended Memory (CCTXEM)	0900h to 0936h	137
PHY Port 0 and Control Cells Multicast Extended Memory (PP0MEM)	0C00h to 0C1Eh	138
PHY Port X Multicast Memory (PPXMM)	0C20h to 0DE0h	139
PPD Memory (PPDM)	1000h to 13FEh	140
Queue X Definition Structure (QXDEF)	2000h to 27E0h	135
Translation RAM Memory (TRAM)	100000h to 17FFFEh	141
SDRAM (SDRAM)	2000000h to 3FFFFFFEh	141

## 14 Registers (continued)

### 14.2 Direct Memory Access Registers

The direct memory access registers are the only registers that can be directly addressed. These registers provide some status and initial control of the device. In addition, the direct memory access register set includes some extended memory access registers, which are used to indirectly access the extended memory registers. All undefined addresses in the direct memory access registers' memory map, 00h to FFh, are reserved and should not be accessed.

**Table 24. Identification 0 (IDNT0) (00h)**

Name	Bit Pos.	Type	Reset	Description
Device ID 0	7:0	RO	4Fh	Device Identification 0.

**Table 25. Identification 1 (IDNT1) (01h)**

Name	Bit Pos.	Type	Reset	Description
Device ID 1	7:0	RO	07h	Device Identification 1.

**Table 26. Identification 2 (IDNT2) (02h)**

Name	Bit Pos.	Type	Reset	Description
Device ID 2	7:0	RO	RN <sup>1</sup>	Revision Number.

1. RN represents the current revision number of the device.

## 14 Registers (continued)

Table 27. Direct Configuration/Control Register (DCCR) (28h)

Name	Bit Pos.	Type	Reset	Description
cyc_per_acc	0	RW	0	<b>Cycles Per Access.</b> This bit is used to indicate the number of cycles per read/write to the translation RAM.  '0' = 2 mclk cycles. '1' = 3 mclk cycles.
srst_reg*	1	RW	0	<b>Software Reset Main Registers.</b> A logic level zero on this bit resets the main registers only. The direct memory access registers (including this one) are not affected by this reset. This bit must be '0' while the mclk PLL configuration 0 and 1 registers are being modified. Active-low.
srst*	2	RW	0	<b>Software Reset.</b> A logic level zero on this bit resets the entire device except the direct memory registers and the main registers. This bit must be '0' while the mclk PLL configuration 0 and 1 registers are being modified and clocks are not present. Active-low.
Reserved	3	RW	0	<b>Reserved.</b> This bit must be programmed to '1.'
rplc_gfc	4	RW	0	<b>Replace GFC.</b> If this bit is '1' and the device is in UNI mode, the GFC field of incoming cells will be replaced during a VPI-VCI translation. If this bit is '0' and the device is in UNI mode, the GFC field will be left untouched. When the device is in NNI mode or when a VPI only translation is performed, this bit has no effect.
big_end	5	RW	0	<b>Big Endian.</b> If this bit is '0,' register fields in the direct address space, 30h to 37h, will be in little-endian format. If '1,' fields in the direct address space, 30h to 37h, will be in big-endian format.
Reserved	7:6	RW	0	<b>Reserved.</b> These bits must be programmed to '0.'

## 14 Registers (continued)

Table 28. Interrupt Service Request (ISREQ) (29h)

Name	Bit Pos.	Type	Reset	Description
Reserved	0	RO	0	<b>Reserved.</b>
int_serv_mainreg	1	RO	0	<b>Interrupt Service Request for Main Registers.</b> When this bit is '1,' an interrupt in the main register group of the extended memory registers needs servicing. The control cell sent and control cell available status bits do not affect this bit. Only enabled interrupts will cause this bit to become set.
int_serv_sdramreg	2	RO	0	<b>Interrupt Service Request for SDRAM Registers.</b> When this bit is '1,' an interrupt in the SDRAM register group of the extended memory registers needs servicing. Only enabled interrupts will cause this bit to become set.
int_serv_utopiareg	3	RO	0	<b>Interrupt Service Request for UTOPIA Registers.</b> When this bit is '1,' an interrupt in the UTOPIA register group of the extended memory registers needs servicing. Only enabled interrupts will cause this bit to become set.
Reserved	4	RO	0	<b>Reserved.</b>
ctrl_cell_sent_sr	5	RO	0	<b>Control Cell Sent Interrupt Service Request.</b> When this bit is '1,' the control cell sent interrupt in the main interrupt status 1 register needs servicing. The corresponding interrupt does not need to be enabled for this bit to become set.
ctrl_cell_av_sr	6	RO	0	<b>Control Cell Available Interrupt Service Request.</b> When this bit is '1,' the control cell available interrupt in the main interrupt status 1 register needs servicing. The corresponding interrupt does not need to be enabled for this bit to become set.
Reserved	7	RO	0	<b>Reserved.</b>

Table 29. mclk PLL Configuration 0 (MPLLCF0) (2Ah)

Name	Bit Pos.	Type	Reset	Description
lf[3:0]	3:0	RW	0	<b>Loop Filter.</b> See Section 5, PLL Configuration, for information on these bits.
Reserved	5:4	RO	0	<b>Reserved.</b>
bypb	6	RW	0	<b>Bypass PLL.</b> If this bit is '0,' the PLL is bypassed. If '1,' the output of the PLL supplies mclk.
plen	7	RW	0	<b>PLL Enable.</b> If this bit is '1,' the PLL is enabled. If '0,' the PLL is disabled.

## 14 Registers (continued)

**Table 30. mclk PLL Configuration 1 (MPLLCF1) (2Bh)**

Name	Bit Pos.	Type	Reset	Description
pll_m[4:0]	4:0	RW	0	<b>PLL M Count Value.</b> See Section 5, PLL Configuration, for information on these bits.
pll_n[2:0]	7:5	RW	0	<b>PLL N Count Value.</b> See Section 5, PLL Configuration, for information on these bits.

**Table 31. GTL+ Slew Rate Configuration (GTLSRCF) (2Eh)**

Name	Bit Pos.	Type	Reset	Description
slew_rate[2:0]	2:0	RW	4h	<b>GTL+ Slew Rate Control [2:0].</b> The slew rates of the GTL+ (cell bus) output signals are controlled by these bits. The minimum slew rate time is 0.9 ns and the maximum slew rate time is 3.8 ns.  "000" = Fastest slew rate "001" "010" "011" = Nominal slew rate (on fast side) "100" = Nominal slew rate (on slow side) "101" "110" "111" = Slowest slew rate
Reserved	3	RW	1	<b>Reserved.</b> Program to '1.'
Reserved	7:4	RW	0	<b>Reserved.</b> Program to '0.'

**Table 32. GTL+ Control (GTLCTRL) (2Fh)**

Name	Bit Pos.	Type	Reset	Description
Reserved	0	R	1	<b>Reserved.</b> Program to '1.'
GTLRPDN	1	RW	1	<b>GTL+ Receive Powerdown.</b> When this bit is cleared to '0,' the GTL+ receivers on the cell bus pins are powered down. Under this condition, no cells can be received from the backplane.  When this bit is set to '1,' the GTL+ receivers are powered up and cells are received from the backplane.
GTLTPDN	2	RW	1	<b>GTL+ Transmit Powerdown.</b> When this bit is cleared to '0,' the GTL+ transmitters on the cell bus pins are powered down. Under this condition, no cells can be transmitted to the backplane.  When this bit is set to '1,' the GTL+ transmitters are powered up and cells are transmitted to the backplane.
Reserved	4:3	R	0	<b>Reserved.</b> Program to '0.'
Reserved	5	R	1	<b>Reserved.</b> Program to '1.'
Reserved	7:6	R	0	<b>Reserved.</b> Program to '0.'

## 14 Registers (continued)

### 14.2.1 Little-Endian Format (big\_end = 0) for Extended Memory Access Registers 30h—37h

**Table 33. Extended Memory Address 1 (Little Endian) (EMA1\_LE) (30h)**

Name	Bit Pos.	Type	Reset	Description
Reserved	4:0	RO	0	<b>Reserved.</b>
ext_a[8:6]	7:5	RW	0	<b>Extended Access Address [8:6].</b> This extended access register points to words.

**Table 34. Extended Memory Address 2 (Little Endian) (EMA2\_LE) (31h)**

Name	Bit Pos.	Type	Reset	Description
ext_a[16:9]	7:0	RW	0	<b>Extended Access Address [16:9].</b> This extended access register points to words.

**Table 35. Extended Memory Address 3 (Little Endian) (EMA3\_LE) (32h)**

Name	Bit Pos.	Type	Reset	Description
ext_a[24:17]	7:0	RW	0	<b>Extended Access Address [24:17].</b> This extended access register points to words.

**Table 36. Extended Memory Address 4 (Little Endian) (EMA4\_LE) (33h)**

Name	Bit Pos.	Type	Reset	Description
ext_a[25]	0	RW	0	<b>Extended Access Address [25].</b> This extended access register points to words.
Reserved	7:1	RO	0	<b>Reserved.</b>

**Table 37. Extended Memory Access (Little Endian) (EMA\_LE) (34h)**

Name	Bit Pos.	Type	Reset	Description
ext_a[5:1]	4:0	RW	0	<b>Extended Access Address [5:1].</b> This extended access register points to words. ext_a[0] is hardwired to '0.'
ext_we[1:0]	6:5	RW	0	<b>Extended Access Write Enable.</b> These bits are active-high write enables for word accesses. If both bits are low, a read is performed. If ext_we[1] is high, the contents of ext_d[15:8] are written, and if ext_we[0] is high, the contents of ext_d[7:0] are written. If both bits are high, both data bytes are written.
ext_strt_acc	7	RW	0	<b>Start Access to Extended Memory.</b> Write a '1' to this bit to start the access to the extended memory registers. This bit is automatically cleared when the access is complete.

## 14 Registers (continued)

**Table 38. Extended Memory Data Low (Little Endian) (EMDL\_LE) (36h)**

Name	Bit Pos.	Type	Reset	Description
ext_d[7:0]	7:0	RW	0	<b>Extended Access Data Low.</b> The least significant byte of data to be written to extended memory is written here before the extended write begins. The least significant byte of data read from extended memory is available here after the extended read is complete.

**Table 39. Extended Memory Data High (Little Endian) (EMDH\_LE) (37h)**

Name	Bit Pos.	Type	Reset	Description
ext_d[15:8]	7:0	RW	0	<b>Extended Access Data High.</b> The most significant byte of data to be written to extended memory is written here before the extended write begins. The most significant byte of data read from extended memory is available here after the extended read is complete.

## 14 Registers (continued)

### 14.2.2 Big-Endian Format (big\_end = 1) for Extended Memory Access Registers 30h—37h

**Table 40. Extended Memory Address 4 (Big Endian) (EMA4\_BE) (30h)**

Name	Bit Pos.	Type	Reset	Description
ext_a[25]	0	RW	0	<b>Extended Access Address [25]</b> . This extended access register points to words.
Reserved	7:1	RO	0	<b>Reserved.</b>

**Table 41. Extended Memory Address 3 (Big Endian) (EMA3\_BE) (31h)**

Name	Bit Pos.	Type	Reset	Description
ext_a[24:17]	7:0	RW	0	<b>Extended Access Address [24:17]</b> . This extended access register points to words.

**Table 42. Extended Memory Address 2 (Big Endian) (EMA2\_BE) (32h)**

Name	Bit Pos.	Type	Reset	Description
ext_a[16:9]	7:0	RW	0	<b>Extended Access Address [16:9]</b> . This extended access register points to words.

**Table 43. Extended Memory Address 1 (Big Endian) (EMA1\_BE) (33h)**

Name	Bit Pos.	Type	Reset	Description
Reserved	4:0	RO	0	<b>Reserved.</b>
ext_a[8:6]	7:5	RW	0	<b>Extended Access Address [8:6]</b> . This extended access register points to words.



## 14 Registers (continued)

**Table 44. Extended Memory Access (Big Endian) (EMA\_BE) (34h)**

Name	Bit Pos.	Type	Reset	Description
ext_a[5:1]	4:0	RW	0	<b>Extended Access Address [5:1].</b> This extended access register points to words. ext_a[0] is hardwired to '0.'
ext_we[1:0]	6:5	RW	0	<b>Extended Access Write Enable.</b> These bits are active-high write enables for word accesses. If both bits are low, a read is performed. If ext_we[1] is high, the contents of ext_d[15:8] are written, and if ext_we[0] is high, the contents of ext_d[7:0] are written. If both bits are high, both data bytes are written.
ext_strt_acc	7	RW	0	<b>Start Access to Extended Memory.</b> Write a '1' to this bit to start the access to the extended memory registers. This bit is automatically cleared when the access is complete.

**Table 45. Extended Memory Data High (Big Endian) (EMDH\_BE) (36h)**

Name	Bit Pos.	Type	Reset	Description
ext_d[15:8]	7:0	RW	0	<b>Extended Access Data High.</b> The most significant byte of data to be written to extended memory is written here before the extended write begins. The most significant byte of data read from extended memory is available here after the extended read is complete.

**Table 46. Extended Memory Data Low (Big Endian) (EMDL\_BE) (37h)**

Name	Bit Pos.	Type	Reset	Description
ext_d[7:0]	7:0	RW	0	<b>Extended Access Data Low.</b> The least significant byte of data to be written to extended memory is written here before the extended write begins. The least significant byte of data read from extended memory is available here after the extended read is complete.

## 14 Registers (continued)

### 14.2.3 General-Purpose I/O Control Registers

Table 47. GPIO Output Enable (GPIO\_OE) (39h)

Name	Bit Pos.	Type	Reset	Description
GPIO_oe[7:0]	7:0	RW	0	<b>GPIO Output Enable.</b> If this bit is set to '1,' the corresponding GPIO pin is an output. If cleared to '0,' the corresponding GPIO pin is an input.

Table 48. GPIO Output Value (GPIO\_OV) (3Bh)

Name	Bit Pos.	Type	Reset	Description
GPIO_out[7:0]	7:0	RW	0	<b>GPIO Output Buffer.</b> Output bits for the GPIO[7:0] pins are written to this buffer. A bit in this buffer is only written to the pin if the corresponding output enable bit is high.

Table 49. GPIO Input Value (GPIO\_IV) (3Dh)

Name	Bit Pos.	Type	Reset	Description
GPIO_in[7:0]	7:0	RO	0	<b>GPIO Input Buffer.</b> This buffer contains the values at the GPIO[7:0] pins.

## 14 Registers (continued)

### 14.2.4 Control Cells

**Table 50. Control Cell Receive Direct Memory (CCRADM) (60h to 93h)**

The control cell receive memory may also be accessed from extended memory. See Table 120.

Name	Offset	Type	Reset	Description
header[31:24]	00h	RO	X	These 52 bytes are the control cell received from the cell bus. This memory space in direct memory is a shadow of the control cell receive extended memory. When present, the control cell should be read from this direct memory space.
header[23:16]	01h			
header[15:8]	02h			
header[7:0]	03h			
payload_byte0	04h			
payload_byte1	05h			
.	.			
.	.			
.	.			
payload_byte46	32h			
payload_byte47	33h			

**Table 51. Control Cell Transmit Direct Memory (CCTXDM) (A0h to D7h)**

The control cell transmit memory may also be accessed from extended memory. See Table 121.

Name	Offset	Type	Reset	Description
cell_bus_routing_header[15:8]	00h	RW	X	These 56 bytes are the cell routing header, the tandem routing header, and the control cell to be transmitted onto the cell bus. This memory space in direct memory is a shadow of the control cell transmit extended memory. A control cell to be transmitted should be written to this direct memory space.
cell_bus_routing_header[7:0]	01h			
tandem_routing_header[15:8]	02h			
tandem_routing_header[7:0]	03h			
header[31:24]	04h			
header[23:16]	05h			
header[15:8]	06h			
header[7:0]	07h			
payload_byte0	08h			
payload_byte1	09h			
.	.			
.	.			
.	.			
payload_byte46	36h			
payload_byte47	37h			

## 14 Registers (continued)

### 14.2.5 Multicast Memories

**Table 52. PHY Port 0 and Control Cells Multicast Direct Memory (PP0MDM) (E0h to FFh)**

The PHY port 0 and control cells multicast memory may also be accessed from extended memory (see Table 122).

Name	Offset	Type	Reset	Description
multicast_receive_enable[15:0]	00h	RW	X	This memory space contains 256 active-high enable bits. Each bit represents a multicast net number from 0 through 255. If a bit is set, the corresponding multicast addressed data cell is sent to the queue group for PHY port 0, or the corresponding multicast control cell is sent to the control cell receive direct and extended memory. The least significant bit is multicast net number 0. This memory space in direct memory is a shadow of the PHY port 0 and control cells multicast extended memory space.
multicast_receive_enable[31:16]	02h			
multicast_receive_enable[47:32]	04h			
.	.			
.	.			
.	.			
multicast_receive_enable[159:144]	12h			
multicast_receive_enable[175:160]	14h			
multicast_receive_enable[191:176]	16h			
multicast_receive_enable[207:192]	18h			
multicast_receive_enable[223:208]	1Ah			
multicast_receive_enable[239:224]	1Ch			
multicast_receive_enable[255:240]	1Eh			

## 14 Registers (continued)

### 14.3 Extended Memory Registers

The *CelXpres* T8207's extended memory registers are mapped into three major blocks: the main registers, the UTOPIA registers, and the SDRAM registers.

#### 14.3.1 Main Registers

**Table 53. Main Configuration 1 (MCF1) (0100h)**

Name	Bit Pos.	Type	Reset	Description
Reserved	7:0	RO	00h	<b>Reserved.</b>
tx_utopia_hi_z	8	RW	0	<p><b>Transmit UTOPIA High Impedance.</b> When the device is in ATM and shared UTOPIA mode, this bit must be cleared to '0':</p> <ul style="list-style-type: none"> <li>■ For the slave device, the u_txsoc output will always be high impedance while the u_txdata[7:0] and u_txprty outputs go high impedance when not active.</li> <li>■ For the master device, the u_txdata[7:0] and u_txprty outputs go high impedance when not active.</li> </ul> <p>When the device is in ATM and nonshared UTOPIA mode and this bit is cleared to '0,' the u_txdata[7:0] and u_txprty outputs go high impedance when not active.</p> <p>When the device is in PHY mode and this bit is cleared to '0,' the u_txsoc, u_txdata[7:0], and u_txprty outputs go high impedance when not active. If the device acts as one of the multi-PHY devices, then this bit must be cleared to '0.'</p> <p>When this bit is set to '1,' the u_txsoc, u_txdata[7:0], and u_txprty outputs never go high impedance.</p>
sdram_bypass	9	RW	0	<p><b>SDRAM Bypass.</b> When this bit is '1,' the T8207 will not use SDRAM and will use only internal memory to buffer cell bus data. Clear this bit to enable the SDRAM interface. Only queue 0 is used when the SDRAM is bypassed.</p>
phyen	10	RW	1	<p><b>PHY Enable.</b> When this bit is '1,' the UTOPIA bus is configured for ATM mode. When '0,' the UTOPIA bus is configured for PHY mode.</p>
tram_qnty_sel	11	RW	0	<p><b>Translation RAM Quantity Select.</b> When two external SRAM devices are used, this bit should be set. When this bit is cleared, only one external SRAM will be accessed using tr_cs*[0].</p>
sp_utopia_sel	12	RW	1	<p><b>Special UTOPIA Mode Select.</b> When this bit is '1,' the T8207 will send 53-byte cells on the UTOPIA bus. When it is '0,' the 55-byte UTOPIA mode is selected, and the tandem routing header bytes will be appended to the beginning of each cell.</p>
tram_size	14:13	RW	0	<p><b>Translation RAM Size.</b> These bits identify the size of the external SRAM used for the look-up table RAM.</p> <p>"00" = 32K bytes  "01" = 64K bytes  "10" = 128K bytes  "11" = 256K bytes</p>
Reserved	15	RW	0	<b>Reserved.</b> Program to '0.'

## 14 Registers (continued)

Table 54. Main Interrupt Status 1 (MIS1) (0102h)

Name	Bit Pos.	Type	Reset	Description
cb_wc_miss	0	ROL	0	<b>Cell Bus Write Clock Missing.</b> This bit is set when the cell bus write clock is inactive for 32 mclk cycles. An interrupt is generated if the corresponding enable bit is set.
cb_rc_miss	1	ROL	0	<b>Cell Bus Read Clock Missing.</b> This bit is set when the cell bus read clock is inactive for 32 mclk cycles. An interrupt is generated if the corresponding enable bit is set.
cb_fs_miss	2	ROL	0	<b>Cell Bus Frame Synchronization Signal Missing.</b> This bit is set when the cell bus frame sync is not asserted every 16 read clock cycles in 16-user mode, or every 32 read clock cycles in 32-user mode. It is also set when cell bus write clock is not present because the frame synchronization signal is clocked onto the cell bus by the write clock. An interrupt is generated if the corresponding enable bit is set.
BIP8_err	3	ROL	0	<b>Bit Interleave Parity Error.</b> This bit is set when an error is detected in the BIP-8 field of the last cell bus frame cycle. An interrupt is generated if the corresponding enable bit is set.
ctrl_cell_ack	4	ROL	0	<b>Control Cell Acknowledged.</b> This bit is set when a control cell is sent on the cell bus and an acknowledge is received. This bit is not set for broadcast or multicast cells. An interrupt is generated if the corresponding enable bit is set.
ctrl_cell_nack	5	ROL	0	<b>Control Cell Not Acknowledged.</b> This bit is set when a control cell is sent on the cell bus and an acknowledge is not received. This bit is not set for broadcast or multicast cells. An interrupt is generated if the corresponding enable bit is set.
cb_grnt_to	6	ROL	0	<b>Cell Bus Grant Time-Out.</b> This bit is set when a cell bus request has not been granted within the time programmed in the cb_req_to bits. An interrupt is generated if the corresponding enable bit is set.
ctrl_cell_sent	7	ROL	0	<b>Control Cell Sent.</b> This bit is set when a control cell is sent onto the cell bus. An interrupt is generated if the corresponding enable bit is set.
ctrl_cell_av	8	ROL	0	<b>Control Cell Available.</b> This bit is set when a control cell is waiting to be read by the microprocessor. An interrupt is generated if the corresponding enable bit is set.
cb_rh_crc_err	9	ROL	0	<b>Cell Bus Routing Header CRC Error.</b> This bit is set when an error is detected in the CRC field of the cell bus routing header. An interrupt is generated if the corresponding enable bit is set.
rx_prty_err	10	ROL	0	<b>Receive Parity Error.</b> This bit is set when the odd parity calculated over the data received on the RX UTOPIA port does not match the u_rxprty signal. An interrupt is generated if the corresponding enable bit is set. When a receive parity error occurs, the cell is still counted as received and is translated and routed.
soc_err	11	ROL	0	<b>Start of Cell Error.</b> This bit is set when a SOC framing error is detected on the RX UTOPIA port. An interrupt is generated if the corresponding enable bit is set. When a start of cell error occurs, the received cells are dropped.
Reserved	15:12	RO	0	<b>Reserved.</b>

**Note:** Immediately following device setup, write FFFFh to this register to clear erroneously set bits.

## 14 Registers (continued)

Table 55. Main Interrupt Enable 1 (MIE1) (0104h)

Name	Bit Pos.	Type	Reset	Description
cb_wc_miss_ie	0	RW	0	<b>Cell Bus Write Clock Missing Interrupt Enable.</b> An interrupt is generated if this bit and the corresponding status bit are set. The interrupt is generated until this bit or the corresponding status bit is reset.
cb_rc_miss_ie	1	RW	0	<b>Cell Bus Read Clock Missing Interrupt Enable.</b> An interrupt is generated if this bit and the corresponding status bit are set. The interrupt is generated until this bit or the corresponding status bit is reset.
cb_fs_miss_ie	2	RW	0	<b>Cell Bus Frame Synchronization Signal Missing Interrupt Enable.</b> An interrupt is generated if this bit and the corresponding status bit are set. The interrupt is generated until this bit or the corresponding status bit is reset.
BIP8_err_ie	3	RW	0	<b>Bit Interleave Parity Error Interrupt Enable.</b> An interrupt is generated if this bit and the corresponding status bit are set. The interrupt is generated until this bit or the corresponding status bit is reset.
ctrl_cell_ack_ie	4	RW	0	<b>Control Cell Acknowledged Interrupt Enable.</b> An interrupt is generated if this bit and the corresponding status bit are set. The interrupt is generated until this bit or the corresponding status bit is reset.
ctrl_cell_nack_ie	5	RW	0	<b>Control Cell Not Acknowledged Interrupt Enable.</b> An interrupt is generated if this bit and the corresponding status bit are set. The interrupt is generated until this bit or the corresponding status bit is reset.
cb_grnt_to_ie	6	RW	0	<b>Cell Bus Grant Time-Out Interrupt Enable.</b> An interrupt is generated if this bit and the corresponding status bit are set. The interrupt is generated until this bit or the corresponding status bit is reset.
ctrl_cell_sent_ie	7	RW	0	<b>Control Cell Sent Interrupt Enable.</b> An interrupt is generated if this bit and the corresponding status bit are set. The interrupt is generated until this bit or the corresponding status bit is reset.
ctrl_cell_av_ie	8	RW	0	<b>Control Cell Available Interrupt Enable.</b> An interrupt is generated if this bit and the corresponding status bit are set. The interrupt is generated until this bit or the corresponding status bit is reset.
cb_rh_crc_err_ie	9	RW	0	<b>Cell Bus Routing Header CRC Error Interrupt Enable.</b> An interrupt is generated if this bit and the corresponding status bit are set. The interrupt is generated until this bit or the corresponding status bit is reset.
rx_prty_err_ie	10	RW	0	<b>Receive Parity Error Interrupt Enable.</b> An interrupt is generated if this bit and the corresponding status bit are set. The interrupt is generated until this bit or the corresponding status bit is reset.
soc_err_ie	11	RW	0	<b>Start of Cell Error Interrupt Enable.</b> An interrupt is generated if this bit and the corresponding status bit are set. The interrupt is generated until this bit or the corresponding status bit is reset.
Reserved	15:12	RO	0	<b>Reserved.</b>

14 Registers (continued)

Table 56. TX UTOPIA Clock Configuration (TXUCCF) (010Ch)

Name	Bit Pos.	Type	Reset	Description
tx_utopia_clk_div	7:0	RW	01h	<p><b>TX UTOPIA Clock Division.</b> The selected TX UTOPIA clock source is divided by the number programmed in these bits as follows:</p> <p>“00000000” = reserved            “00000001” = no division            “00000010” = divide by 2            “00000011” = divide by 3            .            .            .            “11111111” = divide by 255</p> <p>These bits are meaningful only when the T8207 generates the TX UTOPIA clock.</p>
tx_utopia_clk_src_sel	9:8	RW	0	<p><b>TX UTOPIA Clock Source Select.</b> The source of the TX UTOPIA clock is selected via these bits as follows:</p> <p>“00” = cell bus write clock            “01” = reserved            “10” = pclk            “11” = mclk</p> <p>These bits are meaningful only when the T8207 generates the TX UTOPIA clock.</p>
Reserved	10	RW	0	<b>Reserved.</b> Program to ‘0.’
tx_utopia_clk_en	11	RW	0	<p><b>TX UTOPIA Clock Enable.</b> If this bit is ‘1,’ the T8207 generates the TX UTOPIA clock on the u_txclk pin. If this bit is ‘0,’ the u_txclk pin is configured as an input.</p>
Reserved	15:12	RO	0	<b>Reserved.</b>



## 14 Registers (continued)

Table 57. RX UTOPIA Clock Configuration (RXUCCF) (010Eh)

Name	Bit Pos.	Type	Reset	Description
rx_utopia_clk_div	7:0	RW	01h	<p><b>RX UTOPIA Clock Division.</b> The selected RX UTOPIA clock source is divided by the number programmed in these bits as follows:</p> <p>“00000000” = reserved  “00000001” = no division  “00000010” = divide by 2  “00000011” = divide by 3  .  .  .  “11111111” = divide by 255</p> <p>These bits are meaningful only when the T8207 generates the RX UTOPIA clock.</p>
rx_utopia_clk_src_sel	9:8	RW	0	<p><b>RX UTOPIA Clock Source Select.</b> The source of the RX UTOPIA clock is selected via these bits as follows:</p> <p>“00” = cell bus write clock  “01” = reserved  “10” = pclk  “11” = mclk</p> <p>These bits are meaningful only when the T8207 generates the RX UTOPIA clock.</p>
Reserved	10	RW	0	<b>Reserved.</b> Program to ‘0.’
rx_utopia_clk_en	11	RW	0	<p><b>RX UTOPIA Clock Enable.</b> If this bit is ‘1,’ the T8207 generates the RX UTOPIA clock on the u_rxclk pin. If this bit is ‘0,’ the u_rxclk pin is configured as an input.</p>
Reserved	15:12	RO	0	<b>Reserved.</b>

## 14 Registers (continued)

Table 58. Main Configuration/Control (MCFCT) (0110h)

Name	Bit Pos.	Type	Reset	Description
cntl_cell_rd	0	WO	0	<b>Control Cell Has Been Read.</b> Write '1' to this bit after a control cell is read from the control cell FIFO. The '1' will pulse for one clock cycle and will clear to '0' automatically.
cntl_cell_wr	1	RW	0	<b>Control Cell Written in Control Cell Memory.</b> Write '1' to this bit after a control cell is written in the control cell memory. This bit is automatically cleared when the cell is transmitted to the cell bus.
cb_req_pr	3:2	RW	0	<b>Cell Bus Request Priority.</b> These bits indicate the priority of standard requests sent on the cell bus as follows: "00" = disabled, receives cells from cell bus but cannot transmit "01" = low priority "10" = medium priority "11" = high priority
clp_fill_limit	10:4	RW	0	<b>CLP Fill Limit.</b> These bits indicate the TX PHY FIFO fill level at which cells with their CLP bit set to one will be discarded.
cell_drop_en	11	RW	0	<b>Cell Drop Enable.</b> If this bit is one, incoming cells with their CLP bit set to one will be discarded when the TX PHY FIFO fill limit programmed in the clp_fill_limit bits is reached.
inv_crc	12	RW	0	<b>Invert CRC.</b> If this bit is one, the CRC-4 in the routing header is inverted before transmission to the cell bus. This bit is used to simulate errors.
cb_rx_en	13	RW	0	<b>Cell Bus Receive Enable.</b> If this bit is '1,' cells are received from the cell bus. If '0,' cells are not accepted.
slave_en	14	RW	1	<b>Slave Enable.</b> If this bit is '1,' the T8207 is configured as a slave in shared UTOPIA mode. The default value of this bit is '1.' Clear this bit if shared UTOPIA is not used. For shared UTOPIA, only one of the two devices may have this bit cleared. Dynamically changing this bit will cause cell loss. When this bit is '1,' u_rxenb*[0] and u_rxenb*[3:1] become inputs.
Reserved	15	RO	0	<b>Reserved.</b>

Table 59. Main Configuration 2 (MCF2) (0112h)

Name	Bit Pos.	Type	Reset	Description
addr_clav_en	2:0	RW	0	<b>UTOPIA Address, Cell Available, and Enable Signals.</b> These bits configure the number of address, cell available, and enable signals on the UTOPIA bus as follows (see Section 9.6 on page 50):  "000" = 0 ADDR, 4 CLAV, 4 ENB    "100" = 2 ADDR, 2 CLAV, 2 ENB "001" = 4 ADDR, 1 CLAV, 1 ENB    "101" = 2 ADDR, 4 CLAV, 4 ENB "010" = 1 ADDR, 4 CLAV, 4 ENB    "110" = 3 ADDR, 1 CLAV, 1 ENB "011" = 4 ADDR, 2 CLAV, 2 ENB    "111" = 3 ADDR, 2 CLAV, 2 ENB
Reserved	3	RO	0	<b>Reserved.</b>

## 14 Registers (continued)

Table 59. Main Configuration 2 (MCF2) (0112h) (continued)

Name	Bit Pos.	Type	Reset	Description
T8207_sel	4	RW	0	<b>T8207 Select Bit.</b> This bit should be programmed to '1' to obtain all of the T8207 features. If this bit is programmed to '0,' the two additional div_queue bit settings ("100" and "101") affect its operation. If div_queue is programmed to "100" and the T8207_sel bit is '0,' the TX UTOPIA cell buffer is divided into 64 queues, but only 32 are used. In addition, if this bit is programmed to '0,' the UTOPIA Configuration 3 (011Ah) (Table 63), Master Queue 3 (0158h) (Table 80), Master Queue 2 (015Ah) (Table 81), TX PHY FIFO Routing 3 (0178h) (Table 86), and TX PHY FIFO Routing 2 (017Ah) (Table 87) registers do not need to be programmed.
dont_inhibit_rxphy_clav	5	RW	0	<b>Don't Inhibit RX PHY_CLAV.</b> This bit, when set to '1,' keeps the rx_clav signal always asserted high, indicating the capability to accept cells even if the RX UTOPIA FIFO could overrun, or is actually overrun. This bit is valid only when the RX UTOPIA is in PHY mode.  When this bit is cleared to '0,' the rx_clav signal is deasserted if the RX UTOPIA FIFO is considered full.
inhibit_rxuto_fifo_overrun	6	RW	0	<b>Inhibit RX UTOPIA FIFO Overrun.</b> This bit, when set to '1,' prevents the RX UTOPIA FIFO from overflowing by deasserting its rx_enb* signal, even though the rx_clav signal is high when polled, if the RX UTOPIA FIFO is considered full. It is considered full when four cells are stored in it that have not yet been read and processed by the T8207. This bit is valid when the RX UTOPIA is in ATM mode.  When this bit is cleared to '0,' the rx_enb* signal is not deasserted even if the RX UTOPIA FIFO is considered full.
Reserved	7:5	RO	0	<b>Reserved.</b>
div_queue	10:8	RW	0	<b>Divide into Queues.</b> These bits indicate the number of queues used in the TX UTOPIA cell buffer as follows: "000" = 4 queues—32 cells per queue "001" = 8 queues—16 cells per queue "010" = 16 queues—8 cells per queue "011" = 32 queues—4 cells per queue "100" = 64 queues—2 cells per queue "101" = 1 queue—128 cells per queue When the T8207 is configured to UTOPIA level 1 ATM mode or when it is configured for PHY mode, the number of queues selected should be one to maximize cell buffering. T8207_sel = 1 (up to 32 PHYs are supported): When the device is configured to UTOPIA level 2 ATM mode and is connected to multiple PHY ports, each PHY port uses four queues unless 32 PHY ports are selected. If 32 PHY ports are selected, each PHY port uses two queues. Therefore, for 16 or less PHY ports, selecting four queues will provide only for PHY port 0, selecting eight queues will provide only for PHY ports 0 and 1, and so on. For 32 PHY ports, selecting four queues will provide only for PHY ports 0 and 1, selecting eight queues will provide only for PHY ports 0, 1, 2, and 3, and so on. T8207_sel = 0 (up to 16 PHYs are supported): When the device is configured to UTOPIA level 2 ATM mode and is connected to multiple PHY ports, each PHY port uses four queues unless 16 PHY ports are selected. If 16 PHY ports are selected, each PHY port uses two queues. Therefore, for 8 or less PHY ports, selecting four queues will provide only for PHY port 0, selecting eight queues will provide only for PHY ports 0 and 2, and so on. For 16 PHY ports, selecting four queues will provide only for PHY ports 0 and 1, selecting eight queues will provide only for PHY ports 0, 1, 2, and 3, and so on.
Reserved	14:11	RO	0	<b>Reserved.</b>
Reserved	15	RW	0	<b>Reserved.</b> Program this bit to '1.'

## 14 Registers (continued)

Table 60. UTOPIA Configuration (UCF) (0114h)

Name	Bit Pos.	Type	Reset	Description
hec_mask	7:0	RW	55h	<b>Header Error Control (HEC) Mask.</b> An exclusive-OR function is performed on these bits and the HEC value received from the UTOPIA bus before the HEC is checked for error. Also, an exclusive-OR function is performed on these bits and the HEC value calculated before it is transmitted on the UTOPIA bus. Note that a value of zero will not change the HEC value, and a value of FFh will invert the HEC value.
addr_match	12:8	RW	0	<b>Address Match.</b> These bits represent the UTOPIA address of the T8207 in level 2 UTOPIA multi-PHY mode. These bits are only used when the T8207 is configured as a PHY.
Reserved	15:13	RO	0	<b>Reserved.</b>

Table 61. Main Configuration 3 (MCF3) (0116h)

Name	Bit Pos.	Type	Reset	Description
cb_req_to	7:0	RW	0	<b>Cell Bus Request Time-Out.</b> These bits determine the number of frames that a cell bus request may be present before the cell bus grant time-out (cb_grnt_to) status bit is set.
gfc_value	11:8	RW	0	<b>Generic Flow Control (GFC) Value.</b> These are the bits inserted in the GFC field of the TX UTOPIA outgoing cells when the GFC insert feature is enabled.
gfc_insert_en	12	RW	0	<b>GFC Insert Enable.</b> If this bit is '1,' the gfc_value will be inserted in all cells transmitted to the UTOPIA bus.
Reserved	15:13	RO	0	<b>Reserved.</b>

## 14 Registers (continued)

**Table 62. Loopback (LB) (0118h)**

Name	Bit Pos.	Type	Reset	Description
Reserved	3:0	RO	0	<b>Reserved.</b>
routing_header	15:4	RW	0	<b>Routing Header.</b> These bits are substituted for cell bus routing header bits, 15:4, of a received loopback cell before it is retransmitted on the cell bus.

**Table 63. UTOPIA Configuration 3 (UCF3) (011Ah)**

Name	Bit Pos.	Type	Reset	Description
rx_port_en[31:16]	15:0	RW	0	<b>Receive Port Enable.</b> Each bit in this field represents one of the upper 16 PHY ports of 32 possible ports, where the most significant bit is port 31 and the least significant bit is port 16. If the corresponding bit is '1,' cells will be received on the designated UTOPIA port. This register is ignored if the T8207_sel bit in the main configuration 2 register equals '0.'

**Table 64. UTOPIA Configuration 2 (UCF2) (011Ch)**

Name	Bit Pos.	Type	Reset	Description
rx_port_en[15:0]	15:0	RW	0	<b>Receive Port Enable.</b> Each bit in this field represents one of the lower 16 PHY ports of 32 possible ports, where the most significant bit is port 15 and the least significant bit is port 0. If the corresponding bit is '1,' cells will be received on the designated UTOPIA port.

**Table 65. Extended LUT Configuration (ELUTCF) (011Eh)**

Name	Bit Pos.	Type	Reset	Description
lut_rec_form	1:0	RW	0	<b>LUT Record Format.</b> These bits indicate the format of the LUT records as follows: "00" = 8-byte records "01" = 16-byte record with extended monitoring "10" = reserved "11" = reserved
Reserved	15:2	RO	0	<b>Reserved.</b>

## 14 Registers (continued)

Table 66. Extended LUT Control (ELUTCN) (0120h)

Name	Bit Pos.	Type	Reset	Description
spc_cell_cnt_sel0	0	RW	0	<b>Special Cell Count Select 0.</b> When this bit is '1,' cells, whose four least significant bits of their header are "0000," are counted in the special cell count.
spc_cell_cnt_sel1	1	RW	0	<b>Special Cell Count Select 1.</b> When this bit is '1,' cells, whose four least significant bits of their header are "0001," are counted in the special cell count.
spc_cell_cnt_sel2	2	RW	0	<b>Special Cell Count Select 2.</b> When this bit is '1,' cells, whose four least significant bits of their header are "0010," are counted in the special cell count.
spc_cell_cnt_sel3	3	RW	0	<b>Special Cell Count Select 3.</b> When this bit is '1,' cells, whose four least significant bits of their header are "0011," are counted in the special cell count.
spc_cell_cnt_sel4	4	RW	0	<b>Special Cell Count Select 4.</b> When this bit is '1,' cells, whose four least significant bits of their header are "0100," are counted in the special cell count.
spc_cell_cnt_sel5	5	RW	0	<b>Special Cell Count Select 5.</b> When this bit is '1,' cells, whose four least significant bits of their header are "0101," are counted in the special cell count.
spc_cell_cnt_sel6	6	RW	0	<b>Special Cell Count Select 6.</b> When this bit is '1,' cells, whose four least significant bits of their header are "0110," are counted in the special cell count.
spc_cell_cnt_sel7	7	RW	0	<b>Special Cell Count Select 7.</b> When this bit is '1,' cells, whose four least significant bits of their header are "0111," are counted in the special cell count.
spc_cell_cnt_sel8	8	RW	0	<b>Special Cell Count Select 8.</b> When this bit is '1,' cells, whose four least significant bits of their header are "1000," are counted in the special cell count.
spc_cell_cnt_sel9	9	RW	0	<b>Special Cell Count Select 9.</b> When this bit is '1,' cells, whose four least significant bits of their header are "1001," are counted in the special cell count.
spc_cell_cnt_sel10	10	RW	0	<b>Special Cell Count Select 10.</b> When this bit is '1,' cells, whose four least significant bits of their header are "1010," are counted in the special cell count.
spc_cell_cnt_sel11	11	RW	0	<b>Special Cell Count Select 11.</b> When this bit is '1,' cells, whose four least significant bits of their header are "1011," are counted in the special cell count.
spc_cell_cnt_sel12	12	RW	0	<b>Special Cell Count Select 12.</b> When this bit is '1,' cells, whose four least significant bits of their header are "1100," are counted in the special cell count.
spc_cell_cnt_sel13	13	RW	0	<b>Special Cell Count Select 13.</b> When this bit is '1,' cells, whose four least significant bits of their header are "1101," are counted in the special cell count.
spc_cell_cnt_sel14	14	RW	0	<b>Special Cell Count Select 14.</b> When this bit is '1,' cells, whose four least significant bits of their header are "1110," are counted in the special cell count.
spc_cell_cnt_sel15	15	RW	0	<b>Special Cell Count Select 15.</b> When this bit is '1,' cells, whose four least significant bits of their header are "1111," are counted in the special cell count.

## 14 Registers (continued)

Table 67. Cell Bus Configuration/Status (CBCFS) (0130h)

Name	Bit Pos.	Type	Reset	Description
unit_addr*	4:0	RO	ua*[4:0]	<b>Unit Address.</b> These bits indicate the values at the ua*[4:0] inputs. The inputs are active-low, so these bits will have a value of 1Fh for device zero.
cb_arb_sel*	5	RW	1	<b>Cell Bus Arbiter Select.</b> If this bit is '0,' cell bus arbiter is selected. Only one device on the cell bus may be configured as arbiter. All other devices should set this bit to '1.'
cb_usr_mode	6	RW	0	<b>Cell Bus User Mode.</b> If this bit is '0,' 32-user mode is selected on the cell bus. If '1,' 16-user mode is selected.
Reserved	8:7	RO	0	<b>Reserved.</b>
cntrl_cell_prio	9	RW	0	<b>Control Cell Priority.</b> If this bit is cleared to '0,' then cells from the RX PHY FIFO have the highest priority, cells from the control cell TX FIFO have next highest, and finally, cells from the loopback FIFO have the lowest. If this bit is set to '1,' then cells from the control cell TX FIFO have the highest priority, cells from the RX PHY FIFO have the next highest priority, and finally cells from the loopback FIFO have the lowest priority.  <b>Note:</b> It is recommended that this bit be set during the powerup/reset sequence (Section 3), if necessary. It is strongly advised not to set this bit during data flow.
Reserved	15:10	RO	0	<b>Reserved.</b>

Table 68. Main Interrupt Status 2 (MIS2) (0132h)

Name	Bit Pos.	Type	Reset	Description
lb_cell_lost	0	ROL	0	<b>Loopback Cell Lost.</b> This bit is set if a loopback cell is discarded when the loopback FIFO is full. An interrupt is generated if the corresponding enable bit is set.
Reserved	1	ROL	0	<b>Reserved.</b>
cb_in_fifo_ovrn	2	ROL	0	<b>Cell Bus Input FIFO Overflow.</b> This bit is set if the four-cell incoming cell bus input FIFO overflows. If this bit becomes set, mclk may be too slow compared to the cb_wc* input. An interrupt is generated if the corresponding enable bit is set.
tx_phy_fifo_ovrn	3	ROL	0	<b>TX PHY FIFO Overflow.</b> This bit is set if the 128-cell TX PHY FIFO overflows. If this bit becomes set, bandwidth to the SDRAM may be insufficient. An interrupt is generated if the corresponding enable bit is set.
cell_clp1_dis	4	ROL	0	<b>Cell with CLP Set to One Discarded.</b> This bit is set if a cell with its CLP bit set to one is discarded when the 128-cell TX PHY FIFO goes over the clp_fill_limit. An interrupt is generated if the corresponding enable bit is set.
rx_utoxia_fifo_ovrn	5	ROL	0	<b>RX UTOPIA FIFO Overflow.</b> This bit is set if the RX UTOPIA FIFO overflows. If this bit becomes set, bandwidth to the translation RAM or the cell bus may be insufficient. An interrupt is generated if the corresponding enable bit is set.
cntrl_cell_rx_fifo_ovrn	6	ROL	0	<b>Control Cell RX FIFO Overflow.</b> This bit is set when the control cell RX FIFO overflows. An interrupt is generated if the corresponding enable bit is set.
Reserved	15:7	RO	0	<b>Reserved.</b>

## 14 Registers (continued)

Table 69. Main Interrupt Enable 2 (MIE2) (0134h)

Name	Bit Pos.	Type	Reset	Description
lb_cell_lost_ie	0	RW	0	<b>Loopback Cell Lost Interrupt Enable.</b> An interrupt is generated if this bit and the corresponding status bit are set. The interrupt is generated until this bit or the corresponding status bit is reset.
Reserved	1	RW	0	<b>Reserved.</b> Program this bit to zero.
cb_in_fifo_ovrn_ie	2	RW	0	<b>Cell Bus Input FIFO Overrun Interrupt Enable.</b> An interrupt is generated if this bit and the corresponding status bit are set. The interrupt is generated until this bit or the corresponding status bit is reset.
tx_phy_fifo_ovrn_ie	3	RW	0	<b>TX PHY FIFO Overrun Interrupt Enable.</b> An interrupt is generated if this bit and the corresponding status bit are set. The interrupt is generated until this bit or the corresponding status bit is reset.
cell_clp1_dis_ie	4	RW	0	<b>Cell with CLP Set to One Discarded Interrupt Enable.</b> An interrupt is generated if this bit and the corresponding status bit are set. The interrupt is generated until this bit or the corresponding status bit is reset.
rx_utopia_fifo_ovrn_ie	5	RW	0	<b>RX UTOPIA FIFO Overrun Interrupt Enable.</b> An interrupt is generated if this bit and the corresponding status bit are set. The interrupt is generated until this bit or the corresponding status bit is reset.
cntl_cell_rx_fifo_ovrn_ie	6	RW	0	<b>Control Cell RX FIFO Overrun Interrupt Enable.</b> An interrupt is generated if this bit and the corresponding status bit are set. The interrupt is generated until this bit or the corresponding status bit is reset.
Reserved	15:7	RO	0	<b>Reserved.</b>



## 14 Registers (continued)

**Table 70. Misrouted LUT 1 (MLUT1) (0142h)**

Name	Bit Pos.	Type	Reset	Description
mis_cell_lut_sel	15:0	RW	FFFFh	<b>Misrouted Cell LUT Select.</b> Each bit in this field represents one of 16 look-up table memory spaces. The least significant bit is LUT memory space 0. If the corresponding bit is '1,' misrouted cells from the LUT memory space are monitored.

**Table 71. Misrouted LUT 2 (MLUT2) (0144h)**

Name	Bit Pos.	Type	Reset	Description
mis_cell_clr	0	WO	0	<b>Misrouted Cell Header Clear.</b> Write '1' to this bit to clear the previously latched misrouted cell header. The '1' will pulse for one clock cycle and will clear to '0' automatically.
mis_cell_latch	1	RO	0	<b>Misrouted Cell Header Latched.</b> If this bit is set to '1,' a misrouted cell was detected and is stored to the mis_cell_header bits.
Reserved	3:2	RO	0	<b>Reserved.</b>
lst_mis_cell_lut	7:4	RO	0	<b>Last Misrouted Cell LUT.</b> These bits indicate the LUT memory space from which the last misrouted cell was detected.
Reserved	15:8	RO	0	<b>Reserved.</b>

**Table 72. Misrouted Cell Header High (MCHH) (0146h)**

Name	Bit Pos.	Type	Reset	Description
mis_cell_header[31:16]	15:0	RO	0	<b>Misrouted Cell Header Bits [31:16].</b> These bits are cell header bits [31:16] from the first misrouted cell received after the mis_cell_clr bit was set. A cell is considered misrouted if its A and I bits are "00," if its VCI is out of range, or if the lutX_vpi_chk bit is '1' and the unused VPI bits in the incoming cell header are not all zero.

**Table 73. Misrouted Cell Header Low (MCHL) (0148h)**

Name	Bit Pos.	Type	Reset	Description
mis_cell_header[15:0]	15:0	RO	0	<b>Misrouted Cell Header Bits [15:0].</b> These bits are cell header bits [15:0] from the first misrouted cell received after the mis_cell_clr bit was set. A cell is considered misrouted if its A and I bits are "00," if its VCI is out of range, or if the lutX_vpi_chk bit is '1' and the unused VPI bits in the incoming cell header are not all zero.

## 14 Registers (continued)

### 14.3.2 UTOPIA Registers

**Table 74. HEC Interrupt Status 1 (HIS1) (0302h)**

Name	Bit Pos.	Type	Reset	Description
hec_err[31:16]	15:0	RW	0	<b>HEC Error.</b> Each bit in this field represents one of the upper 16 PHY ports where the most significant bit is port 31 and the least significant bit is port 16. The associated bit is set when an HEC error is detected on the PHY port. An interrupt is generated if the corresponding enable bit is set. When a HEC error occurs, the cell is still counted as received and is translated and routed.

**Table 75. HEC Interrupt Enable 1 (HIE1) (0304h)**

Name	Bit Pos.	Type	Reset	Description
hec_err_ie[31:16]	15:0	RW	0	<b>HEC Error Interrupt Enable.</b> An interrupt is generated if this bit and the corresponding status bit are set. The interrupt is generated until this bit or the corresponding status bit is reset.

**Table 76. HEC Interrupt Status (HIS) (0306h)**

Name	Bit Pos.	Type	Reset	Description
hec_err[15:0]	15:0	ROL	0	<b>HEC Error.</b> Each bit in this field represents one of the lower 16 PHY ports where the most significant bit is port 15 and the least significant bit is port 0. The associated bit is set when an HEC error is detected on the PHY port. An interrupt is generated if the corresponding enable bit is set. When a HEC error occurs, the cell is still counted as received and is translated and routed.

**Table 77. HEC Interrupt Enable (HIE) (0308h)**

Name	Bit Pos.	Type	Reset	Description
hec_err_ie[15:0]	15:0	RW	0	<b>HEC Error Interrupt Enable.</b> An interrupt is generated if this bit and the corresponding status bit are set. The interrupt is generated until this bit or the corresponding status bit is reset.

**Table 78. LUT Interrupt Service Request (LUTISR) (030Eh)**

Name	Bit Pos.	Type	Reset	Description
lut_int_serv[15:0]	15:0	RO	0	<b>LUT Interrupt Service.</b> Each bit in this field represents one of 16 LUT configuration/status registers. The least significant bit represents LUT 0 configuration/status register. If the corresponding bit is '1,' the specific LUT configuration/status register has interrupt status bits that need servicing.

## 14 Registers (continued)

Table 79. LUT X Configuration/Status (LUTXCFS) (0320h to 033Eh)

Name	Bit Pos.	Type	Reset	Description
lut_en	0	RW	0	<b>LUT Memory Space Enable.</b> If this bit is '1,' the LUT memory space is enabled. When this bit is '0,' cells from the associated PHY port are discarded, are not flagged as misrouted, and are not counted as a received cell.  <b>Note:</b> When 16 or less PHY ports are used, each PHY port has its own look-up table memory space. For 16 or less PHY ports, PHY port 0 uses LUT 0 memory space, PHY port 1 uses LUT 1 memory space, and so on. When greater than 16 PHY ports are used, even and odd PHY ports must share the look-up memory space. For greater than 16 PHY ports, PHY ports 0 and 1 use LUT 0 memory space, PHY ports 2 and 3 use LUT 1 memory space, PHY ports 4 and 5 use LUT 2 memory space, and so on.
Reserved	3:1	RO	0	<b>Reserved.</b>
mis_cell	4	ROL	0	<b>Misrouted Cell to LUT.</b> This bit is set when a cell's translation record has its A and I bits equal to '0.' An interrupt is generated if the corresponding enable bit is set.
vci_or	5	ROL	0	<b>VCI Out of Range.</b> This bit is set when an incoming cell's VCI is greater than the allowed range. An interrupt is generated if the corresponding enable bit is set.
vpi_or	6	ROL	0	<b>VPI Out of Range.</b> This bit is set when one of the incoming cell's unmasked VPI bits is not '0' and the lutX_vpi_chk bit equals '1.' An interrupt is generated if the corresponding enable bit is set.
Reserved	9:7	RO	0	<b>Reserved.</b>
mis_cell_ie	10	RW	0	<b>Misrouted Cell to LUT Interrupt Enable.</b> An interrupt is generated if this bit and the corresponding status bit are set. The interrupt is generated until this bit or the corresponding status bit is reset.
vci_or_ie	11	RW	0	<b>VCI Out of Range Interrupt Enable.</b> An interrupt is generated if this bit and the corresponding status bit are set. The interrupt is generated until this bit or the corresponding status bit is reset.
vpi_or_ie	12	RW	0	<b>VPI Out of Range Interrupt Enable.</b> An interrupt is generated if this bit and the corresponding status bit are set. The interrupt is generated until this bit or the corresponding status bit is reset.
Reserved	15:13	RO	0	<b>Reserved.</b>

The letter X in the register name represents the 16 PHY port look-up tables. The addresses of the 16 configuration/status registers are shown below.

Register Name	Register Address	Register Name	Register Address
LUT 0 Configuration/Status	0320h	LUT 8 Configuration/Status	0330h
LUT 1 Configuration/Status	0322h	LUT 9 Configuration/Status	0332h
LUT 2 Configuration/Status	0324h	LUT 10 Configuration/Status	0334h
LUT 3 Configuration/Status	0326h	LUT 11 Configuration/Status	0336h
LUT 4 Configuration/Status	0328h	LUT 12 Configuration/Status	0338h
LUT 5 Configuration/Status	032Ah	LUT 13 Configuration/Status	033Ah
LUT 6 Configuration/Status	032Ch	LUT 14 Configuration/Status	033Ch
LUT 7 Configuration/Status	032Eh	LUT 15 Configuration/Status	033Eh

## 14 Registers (continued)

### 14.3.2.1 TX UTOPIA Configuration

**Table 80. Master Queue 3 (MQ3) (0158h)**

Name	Bit Pos.	Type	Reset	Description
mast_queue_in[63:48]	15:0	RW	0	<p><b>Master Queue Indication [63:48].</b> Each bit in this field represents one of 16 queues from the 64 queues in the T8207 device, where the least significant bit is queue 48, and the most significant bit is queue 63. These bits must be set if 64 queues are used. This register is ignored if the T8207_sel bit in the main configuration 2 register equals '0.'</p> <p><b>Note:</b> These bits must be programmed even when the device is not used in shared UTOPIA mode.</p>

**Table 81. Master Queue 2 (MQ2) (015Ah)**

Name	Bit Pos.	Type	Reset	Description
mast_queue_in[47:32]	15:0	RW	0	<p><b>Master Queue Indication [47:32].</b> Each bit in this field represents one of 16 queues from the 64 queues in the T8207 device, where the least significant bit is queue 32, and the most significant bit is queue 47. These bits must be set if 64 queues are used. This register is ignored if the T8207_sel bit in the main configuration 2 register equals '0.'</p> <p><b>Note:</b> These bits must be programmed even when the device is not used in shared UTOPIA mode.</p>

## 14 Registers (continued)

**Table 82. Master Queue 0 (MQ0) (015Ch)**

Name	Bit Pos.	Type	Reset	Description
mast_queue_in[31:16]	15:0	RW	0	<p><b>Master Queue Indication [31:16].</b> Each bit in this field represents one of 16 queues from the 64 queues in the T8207 device, where the least significant bit is queue 16 and most significant bit is queue 31. These bits indicate which queues in the device are enabled for shared UTOPIA mode. If the associated bit is '1,' it indicates that the queue is enabled. These bits must be programmed in both the master and slave devices.</p> <p><b>Note:</b> These bits must be programmed even when the device is not used in shared UTOPIA mode.</p> <p><b>Note:</b> Shared UTOPIA mode supports up to 32 queues only.</p>

**Table 83. Master Queue 1 (MQ1) (015Eh)**

Name	Bit Pos.	Type	Reset	Description
mast_queue_in[15:0]	15:0	RW	0	<p><b>Master Queue Indication [15:0].</b> Each bit in this field represents one of 16 queues from the 64 queues in the T8207 device, where the least significant bit is queue 0, and most significant bit is queue 15. These bits indicate which queues in the device are enabled for shared UTOPIA mode. If the associated bit is '1,' it indicates that the queue is enabled. These bits must be programmed in both the master and slave devices.</p> <p><b>Note:</b> These bits must be programmed even when the device is not used in shared UTOPIA mode.</p> <p><b>Note:</b> Shared UTOPIA mode supports up to 32 queues only.</p>

## 14 Registers (continued)

**Table 84. Slave Queue 0 (SQ0) (016Ch)**

Name	Bit Pos.	Type	Reset	Description
slav_queue_in[31:16]	15:0	RW	0	<p><b>Slave Queue Indication [31:16].</b> The bits in this register are used only in shared UTOPIA mode, and only 32 queues are supported in shared UTOPIA mode. Each bit in this field represents one of the upper 16 queues from these 32 queues in the slave device, where the least significant bit is queue 16, and most significant bit is queue 31. These bits indicate which queues in the slave device are enabled for shared UTOPIA mode. If the associated bit is '1,' it indicates to the master that the queue is enabled. These bits are only meaningful in shared UTOPIA mode and must be programmed in the master device.</p> <p><b>Note:</b> Shared UTOPIA mode supports up to 32 queues only.</p>

**Table 85. Slave Queue 1 (SQ1) (016Eh)**

Name	Bit Pos.	Type	Reset	Description
slav_queue_in[15:0]	15:0	RW	0	<p><b>Slave Queue Indication [15:0].</b> The bits in this register are used only in shared UTOPIA mode, and only 32 queues are supported in shared UTOPIA mode. Each bit in this field represents one of the lower 16 queues from these 32 queues in the slave device, where the least significant bit is queue 0, and most significant bit is queue 15. These bits indicate which queues in the slave device are enabled for shared UTOPIA mode. If the associated bit is '1,' it indicates to the master that the queue is enabled. These bits are only meaningful in shared UTOPIA mode and must be programmed in the master device.</p> <p><b>Note:</b> Shared UTOPIA mode supports up to 32 queues only.</p>

## 14 Registers (continued)

Table 86. TX PHY FIFO Routing 3 (TXPFR3) (0178h)

Name	Bit Pos.	Type	Reset	Description
port_rte[63:48]	15:0	RW	0	<p><b>Port Route [63:48].</b> These port routing bits are only used when 32 PHY ports are used. Each bit in this field represents one of 16 queues from the 64 queues in the device, where the least significant bit is queue 48, and the most significant bit is queue 63. These 64 queues are divided into sixteen groups of four queues each. The four queues of each group are divided between two PHY ports, as follows:</p> <ul style="list-style-type: none"> <li>Group 0—queues 0 to 3—ports 0 and 1</li> <li>Group 1—queues 4 to 7—ports 2 and 3</li> <li>Group 2—queues 8 to 11—ports 4 and 5</li> <li>Group 3—queues 12 to 15—ports 6 and 7</li> <li>Group 4—queues 16 to 19—ports 8 and 9</li> <li>Group 5—queues 20 to 23—ports 10 and 11</li> <li>Group 6—queues 24 to 27—ports 12 and 13</li> <li>Group 7—queues 28 to 31—ports 14 and 15</li> <li>Group 8—queues 32 to 35—ports 16 and 17</li> <li>Group 9—queues 36 to 39—ports 18 and 19</li> <li>Group 10—queues 40 to 43—ports 20 and 21</li> <li>Group 11—queues 44 to 47—ports 22 and 23</li> <li>Group 12—queues 48 to 51—ports 24 and 25</li> <li>Group 13—queues 52 to 55—ports 26 and 27</li> <li>Group 14—queues 56 to 59—ports 28 and 29</li> <li>Group 15—queues 60 to 63—ports 30 and 31</li> </ul> <p>The bits in this field assign each queue in the group to either the odd- or even-numbered PHY port in the group. If a bit is cleared to '0,' the corresponding queue is assigned to the even-numbered port. If the bit is set to '1,' the corresponding queue is assigned to the odd-numbered port. For 32 PHY ports, if the device is configured in <b>normal</b> 32-port mode, as described in Section 9.2.2, Outgoing ATM Mode (Cells Sent by T8207), and in Section 11.4, Queuing, this register is programmed to "1010101010101010." With this setting, PHY port 24 is assigned queues 48 and 50, PHY port 25 is assigned queues 49 and 51, PHY port 26 is assigned queues 52 and 54, PHY port 27 is assigned queues 53 and 55, and so on.</p>

14 Registers (continued)

Table 87. TX PHY FIFO Routing 2 (TXPFR2) (017Ah)

Name	Bit Pos.	Type	Reset	Description
port_rte[47:32]	15:0	RW	0	<p><b>Port Route [47:32].</b> These port routing bits are only used when 32 PHY ports are used. Each bit in this field represents one of 16 queues from the 64 queues in the device, where the least significant bit is queue 32, and the most significant bit is queue 47. These 64 queues are divided into sixteen groups of four queues each. The four queues of each group are divided between two PHY ports, as follows:</p> <ul style="list-style-type: none"> <li>Group 0—queues 0 to 3—ports 0 and 1</li> <li>Group 1—queues 4 to 7—ports 2 and 3</li> <li>Group 2—queues 8 to 11—ports 4 and 5</li> <li>Group 3—queues 12 to 15—ports 6 and 7</li> <li>Group 4—queues 16 to 19—ports 8 and 9</li> <li>Group 5—queues 20 to 23—ports 10 and 11</li> <li>Group 6—queues 24 to 27—ports 12 and 13</li> <li>Group 7—queues 28 to 31—ports 14 and 15</li> <li>Group 8—queues 32 to 35—ports 16 and 17</li> <li>Group 9—queues 36 to 39—ports 18 and 19</li> <li>Group 10—queues 40 to 43—ports 20 and 21</li> <li>Group 11—queues 44 to 47—ports 22 and 23</li> <li>Group 12—queues 48 to 51—ports 24 and 25</li> <li>Group 13—queues 52 to 55—ports 26 and 27</li> <li>Group 14—queues 56 to 59—ports 28 and 29</li> <li>Group 15—queues 60 to 63—ports 30 and 31</li> </ul> <p>The bits in this field assign each queue in the group to either the odd- or even-numbered PHY port in the group. If a bit is cleared to '0,' the corresponding queue is assigned to the even-numbered port. If the bit is set to '1,' the corresponding queue is assigned to the odd-numbered port. For 32 PHY ports, if the device is configured in <b>normal</b> 32-port mode, as described in Section 9.2.2, Outgoing ATM Mode (Cells Sent by T8207), and in Section 11.4, Queuing, this register is programmed to "1010101010101010." With this setting, PHY port 16 is assigned queues 32 and 34, PHY port 17 is assigned queues 33 and 35, PHY port 18 is assigned queues 36 and 38, PHY port 19 is assigned queues 37 and 39, and so on.</p>



## 14 Registers (continued)

Table 88. TX PHY FIFO Routing 0 (TXPFR0) (017Ch)

Name	Bit Pos.	Type	Reset	Description
port_rte[31:16]	15:0	RW	0	<p><b>Port Route [31:16].</b> Each bit in this field represents one of 16 queues from the 64 queues in the device, where the least significant bit is queue 16, and the most significant bit is queue 31. These 64 queues are divided into sixteen groups of four queues each. Except in a special case of sixteen ports, the four queues of each group are divided between two PHY ports, as follows:</p> <p>Group 0—queues 0 to 3—ports 0 and 1            Group 1—queues 4 to 7—ports 2 and 3            Group 2—queues 8 to 11—ports 4 and 5            Group 3—queues 12 to 15—ports 6 and 7            Group 4—queues 16 to 19—ports 8 and 9            Group 5—queues 20 to 23—ports 10 and 11            Group 6—queues 24 to 27—ports 12 and 13            Group 7—queues 28 to 31—ports 14 and 15            Group 8—queues 32 to 35—ports 16 and 17            Group 9—queues 36 to 39—ports 18 and 19            Group 10—queues 40 to 43—ports 20 and 21            Group 11—queues 44 to 47—ports 22 and 23            Group 12—queues 48 to 51—ports 24 and 25            Group 13—queues 52 to 55—ports 26 and 27            Group 14—queues 56 to 59—ports 28 and 29            Group 15—queues 60 to 63—ports 30 and 31</p> <p>The bits in this field assign each queue in the group to either the odd- or even-numbered PHY port in the group. If a bit is cleared to '0,' the corresponding queue is assigned to the even-numbered port. If the bit is set to '1,' the corresponding queue is assigned to the odd-numbered port. For eight PHY ports, where ports 0, 2, 4, 6, 8, 10, and 14 are used, this register is set to "0000000000000000," ultimately assigning 4 queues per port. For 32 PHY ports, if the device is configured in <b>normal</b> 32-port mode, as described in Section 9.2.2, <i>Outgoing ATM Mode (Cells Sent by T8207)</i>, and in Section 11.4, <i>Queuing</i>, this register is programmed to "1010101010101010." With this setting, PHY port 8 is assigned queues 16 and 18, PHY port 9 is assigned queues 17 and 19, PHY port 10 is assigned queues 20 and 22, PHY port 11 is assigned queues 21 and 23, and so on.</p> <p>For the special case of sixteen ports, if the T8207_sel bit is set, these bits are ignored, and each port is assigned all four queues in the group. PHY 0 is assigned queue group 0, or queues 0, 1, 2, and 3, PHY 1 is assigned queue group 1, or queues 4, 5, 6, and 7, and so on.</p> <p>For sixteen PHY ports, if the T8207_sel bit is cleared, the sixteen ports can only use queues 0 to 31, and the queues are shared between odd- and even-numbered ports. In the <b>normal</b> 16-port mode, as described in Section 9.2.2, <i>Outgoing ATM Mode (Cells Sent by T8207)</i>, and in Section 11.4, <i>Queuing</i>, this register is programmed to "1010101010101010." With this setting, PHY port 8 is assigned queues 16 and 18, PHY port 9 is assigned queues 17 and 19, PHY port 10 is assigned queues 20 and 22, PHY port 11 is assigned queues 21 and 23, and so on.</p>

14 Registers (continued)

Table 89. TX PHY FIFO Routing 1 (TXPFR1) (017Eh)

Name	Bit Pos.	Type	Reset	Description
port_rte[15:0]	15:0	RW	0	<p><b>Port Route [15:0].</b> Port Route [15:0]. Each bit in this field represents one of 16 queues from the 64 queues in the device, where the least significant bit is queue 0, and the most significant bit is queue 15. These 64 queues are divided into sixteen groups of four queues each. Except in a special case of sixteen ports, the four queues of each group are divided between two PHY ports, as follows:</p> <p>Group 0—queues 0 to 3—ports 0 and 1            Group 1—queues 4 to 7—ports 2 and 3            Group 2—queues 8 to 11—ports 4 and 5            Group 3—queues 12 to 15—ports 6 and 7            Group 4—queues 16 to 19—ports 8 and 9            Group 5—queues 20 to 23—ports 10 and 11            Group 6—queues 24 to 27—ports 12 and 13            Group 7—queues 28 to 31—ports 14 and 15            Group 8—queues 32 to 35—ports 16 and 17            Group 9—queues 36 to 39—ports 18 and 19            Group 10—queues 40 to 43—ports 20 and 21            Group 11—queues 44 to 47—ports 22 and 23            Group 12—queues 48 to 51—ports 24 and 25            Group 13—queues 52 to 55—ports 26 and 27            Group 14—queues 56 to 59—ports 28 and 29            Group 15—queues 60 to 63—ports 30 and 31</p> <p>The bits in this field assign each queue in the group to either the odd- or even-numbered PHY port in the group. If a bit is cleared to '0,' the corresponding queue is assigned to the even-numbered port. If the bit is set to '1,' the corresponding queue is assigned to the odd-numbered port. For eight PHY ports, where ports 0, 2, 4, 6, 8, 10, and 14 are used, this register is set to "0000000000000000," ultimately assigning 4 queues per port. For 32 PHY ports, if the device is configured in <b>normal</b> 32-port mode, as described in Section 9.2.2, Outgoing ATM Mode (Cells Sent by T8207), and in Section 11.4, Queuing, this register is programmed to "1010101010101010." With this setting, PHY port 0 is assigned queues 0 and 2, PHY port 1 is assigned queues 1 and 3, PHY port 2 is assigned queues 4 and 6, PHY port 3 is assigned queues 5 and 7, and so on.</p> <p>For the special case of sixteen ports, if the T8207_sel bit is set, these bits are ignored, and each port is assigned all four queues in the group. PHY 0 is assigned queue group 0, or queues 0, 1, 2, and 3, PHY 1 is assigned queue group 1, or queues 4, 5, 6, and 7, and so on.</p> <p>For sixteen PHY ports, if the T8207_sel bit is cleared, the sixteen ports can only use queues 0 to 31, and the queues are shared between odd- and even-numbered ports. In the <b>normal</b> 16-port mode, as described in Section 9.2.2, Outgoing ATM Mode (Cells Sent by T8207), and in Section 11.4, Queuing, this register is programmed to "1010101010101010." With this setting, PHY port 0 is assigned queues 0 and 2, PHY port 1 is assigned queues 1 and 3, PHY port 2 is assigned queues 4 and 6, PHY port 3 is assigned queues 5 and 7, and so on.</p>

## 14 Registers (continued)

Table 90. Routing Information 1 (RI1) (0200h)

Name	Bit Pos.	Type	Reset	Description
mphy1_sel[5:0]	5:0	RW	X	<b>Multi-PHY 1 Select [5:0].</b> The mphy1_sel[5:0] bit field selects which bit of the cell header, the cell bus routing header, or the tandem routing header is used as this port group address bit.
mphy2_sel[5:0]	11:6	RW	X	<b>Multi-PHY 2 Select [5:0].</b> The mphy2_sel[5:0] bit field selects which bit of the cell header, the cell bus routing header, or the tandem routing header is used as this port group address bit.
				<b>Multi-PHY 1 and 2 Select [5:0].</b> The port group address bits are used to determine the queue group to which the cell is directed. The priority select bits are used to determine the queue in the queue group to which the cell is directed. The mphy3_sel[5:0] bits select the most significant bit of the port group address, and the mphy0_sel[5:0] bits select the least significant bit of the port group address. A value of zero to 31 selects bits in the cell header where zero is the CLP bit and 31 is the most significant bit of the GFC/VPI field. A value of 32 to 47 selects bits in the tandem routing header where 32 is the least significant bit and 47 is the most significant bit. A value of 48 to 63 selects bits in the cell bus routing header where 48 is the least significant bit and 63 is the most significant bit. The value, "110000," is a special case and may be used to force the value of this bit to '0.' If this bit is forced to zero, the bit position in the resultant pointer is always '0' and is not extracted from the received cell.
Reserved	15:12	RO	0	<b>Reserved.</b>

14 Registers (continued)

Table 91. Routing Information 2 (RI2) (0202h)

Name	Bit Pos.	Type	Reset	Description
mphy3_sel[5:0]	5:0	RW	X	<b>Multi-PHY 3 Select [5:0].</b> The mphy3_sel[5:0] bit field selects which bit of the cell header, the cell bus routing header, or the tandem routing header is used as this port group address bit. These bits are ignored when the T8207_sel bit equals '0.' These bits must be programmed if the T8207_sel bit in the main configuration 2 register equals '1.'
mphy0_sel[5:0]	11:6	RW	X	<b>Multi-PHY 0 Select [5:0].</b> The mphy0_sel[5:0] bit field selects which bit of the cell header, the cell bus routing header, or the tandem routing header is used as this port group address bit.  <b>Multi-PHY 0 and 3 Select [5:0].</b> The port group address bits are used to determine the queue group to which the cell is directed. The priority select bits are used to determine the queue in the queue group to which the cell is directed. The mphy3_sel[5:0] bits select the most significant bit of the port group address, and the mphy0_sel[5:0] bits select the least significant bit of the port group address. A value of zero to 31 selects bits in the cell header where zero is the CLP bit and 31 is the most significant bit of the GFC/VPI field. A value of 32 to 47 selects bits in the tandem routing header where 32 is the least significant bit and 47 is the most significant bit. A value of 48 to 63 selects bits in the cell bus routing header where 48 is the least significant bit and 63 is the most significant bit. The value, "110000," is a special case and may be used to force the value of this bit to '0.' If this bit is forced to zero, the bit position in the resultant pointer is always '0' and is not extracted from the received cell.
Reserved	15:12	RO	0	<b>Reserved.</b>

## 14 Registers (continued)

Table 92. Routing Information 3 (RI3) (0204h)

Name	Bit Pos.	Type	Reset	Description
prior0_sel[5:0]	5:0	RW	X	<b>Priority 0 Select.</b> The prior0_sel[5:0] bit field selects which bit of the cell header, the cell bus routing header, or the tandem routing header is used as this priority bit.
prior1_sel[5:0]	11:6	RW	X	<b>Priority 1 Select.</b> The prior1_sel[5:0] bit field selects which bit of the cell header, the cell bus routing header, or the tandem routing header is used as this priority bit.
				<b>Priority 0 and 1 Select.</b> The port group address bits are used to determine the queue group to which the cell is directed. The priority select bits are used to determine the queue in the queue group to which the cell is directed. The prior1_sel[5:0] bits select the most significant bit of the priority number in the specified group, and the prior0_sel[5:0] bits select the least significant bit of the priority number. A value of zero to 31 selects bits in the cell header where zero is the CLP bit and 31 is the most significant bit of the GFC/VPI field. A value of 32 to 47 selects bits in the tandem routing header where 32 is the least significant bit and 47 is the most significant bit. A value of 48 to 63 selects bits in the cell bus routing header where 48 is the least significant bit and 63 is the most significant bit. The value, "110000," is a special case and may be used to force the value of this bit to '0.' If this bit is forced to zero, the bit position in the resultant pointer is always '0' and is not extracted from the received cell.
Reserved	15:12	RO	0	<b>Reserved.</b>

## 14 Registers (continued)

Table 93. PPD Information 1 (PPDI1) (0206h)

Name	Bit Pos.	Type	Reset	Description
ppd_pnt12_sel[5:0]	5:0	RW	X	<p><b>PPD Pointer 12 Select.</b> The ppd_pnt12_sel[5:0] bit field selects which bit of the cell header, the cell bus routing header, or the tandem routing header is used as this offset bit.</p> <p>The PPD pointer select bits are used to create an offset into the PPD state memory. The PPD state memory is used to keep track of AAL5 virtual channels for partial packet discard. Up to 8192 virtual channels may be supported with these select fields. The ppd_pnt12_sel[5:0] bits select the most significant bit of the PPD state memory offset, and the ppd_pnt0_sel[5:0] bits select the least significant bit of the offset. A value of zero to 31 selects bits in the cell header where zero is the CLP bit and 31 is the most significant bit of the GFC/VPI field. A value of 32 to 47 selects bits in the tandem routing header where 32 is the least significant bit and 47 is the most significant bit. A value of 48 to 63 selects bits in the cell bus routing header where 48 is the least significant bit and 63 is the most significant bit. The value, "110000," is a special case and may be used to force the value of this bit to '0.' If this bit is forced to zero, the bit position in the resultant pointer is always '0' and is not extracted from the received cell.</p>
ppd_en_sel[5:0]	11:6	RW	X	<p><b>PPD Enable Select.</b> The ppd_en_sel[5:0] bit field selects which bit of the cell header, the cell bus routing header, or the tandem routing header is used as this enable bit. The PPD enable select bits are used to identify the AAL5 virtual channel and to enable PPD. A value of zero to 31 selects bits in the cell header where zero is the CLP bit and 31 is the most significant bit of the GFC/VPI field. A value of 32 to 47 selects bits in the tandem routing header where 32 is the least significant bit and 47 is the most significant bit. A value of 48 to 63 selects bits in the cell bus routing header where 48 is the least significant bit and 63 is the most significant bit. The value, "110000," is a special case and may be used to force the value of this bit to '0.' If this selected bit in the received cell is one, the partial packet discard feature is enabled.</p>
Reserved	15:12	RO	0	<b>Reserved.</b>

## 14 Registers (continued)

Table 94. PPD Information 2 (PPDI2) (0208h)

Name	Bit Pos.	Type	Reset	Description
ppd_pnt10_sel[5:0]	5:0	RW	X	<b>PPD Pointer 10 Select.</b> The ppd_pnt10_sel[5:0] bit field selects which bit of the cell header, the cell bus routing header, or the tandem routing header is used as this offset bit.
ppd_pnt11_sel[5:0]	11:6	RW	X	<b>PPD Pointer 11 Select.</b> The ppd_pnt11_sel[5:0] bit field selects which bit of the cell header, the cell bus routing header, or the tandem routing header is used as this offset bit.
				<b>PPD Pointer 10 and 11 Select.</b> The ppd pointer select bits are used to create an offset into the PPD state memory. The PPD state memory is used to keep track of AAL5 virtual channels for partial packet discard. Up to 8192 virtual channels may be supported with these select fields. The ppd_pnt12_sel[5:0] bits select the most significant bit of the PPD state memory offset, and the ppd_pnt0_sel[5:0] bits select the least significant bit of the offset. A value of zero to 31 selects bits in the cell header where zero is the CLP bit and 31 is the most significant bit of the GFC/VPI field. A value of 32 to 47 selects bits in the tandem routing header where 32 is the least significant bit and 47 is the most significant bit. A value of 48 to 63 selects bits in the cell bus routing header where 48 is the least significant bit and 63 is the most significant bit. The value, "110000," is a special case and may be used to force the value of this bit to '0.' If this bit is forced to zero, the bit position in the resultant pointer is always '0' and is not extracted from the received cell.
Reserved	15:12	RO	0	<b>Reserved.</b>

## 14 Registers (continued)

Table 95. PPD Information 3 (PPDI3) (020Ah)

Name	Bit Pos.	Type	Reset	Description
ppd_pnt8_sel[5:0]	5:0	RW	X	<b>PPD Pointer 8 Select.</b> The ppd_pnt8_sel[5:0] bit field selects which bit of the cell header, the cell bus routing header, or the tandem routing header is used as this offset bit.
ppd_pnt9_sel[5:0]	11:6	RW	X	<b>PPD Pointer 9 Select.</b> The ppd_pnt9_sel[5:0] bit field selects which bit of the cell header, the cell bus routing header, or the tandem routing header is used as this offset bit.
				<b>PPD Pointer 8 and 9 Select.</b> The ppd pointer select bits are used to create an offset into the PPD state memory. The PPD state memory is used to keep track of AAL5 virtual channels for partial packet discard. Up to 8192 virtual channels may be supported with these select fields. The ppd_pnt12_sel[5:0] bits select the most significant bit of the PPD state memory offset, and the ppd_pnt0_sel[5:0] bits select the least significant bit of the offset. A value of zero to 31 selects bits in the cell header where zero is the CLP bit and 31 is the most significant bit of the GFC/VPI field. A value of 32 to 47 selects bits in the tandem routing header where 32 is the least significant bit and 47 is the most significant bit. A value of 48 to 63 selects bits in the cell bus routing header where 48 is the least significant bit and 63 is the most significant bit. The value, "110000," is a special case and may be used to force the value of this bit to '0.' If this bit is forced to zero, the bit position in the resultant pointer is always '0' and is not extracted from the received cell.
Reserved	15:12	RO	0	<b>Reserved.</b>



## 14 Registers (continued)

Table 96. PPD Information 4 (PPDI4) (020Ch)

Name	Bit Pos.	Type	Reset	Description
ppd_pnt6_sel[5:0]	5:0	RW	X	<p><b>PPD Pointer 6 Select.</b> The ppd_pnt6_sel[5:0] bit field selects which bit of the cell header, the cell bus routing header, or the tandem routing header is used as this offset bit.</p> <p><b>PPD Pointer 7 Select.</b> The ppd_pnt7_sel[5:0] bit field selects which bit of the cell header, the cell bus routing header, or the tandem routing header is used as this offset bit.</p> <p><b>PPD Pointer 6 and 7 Select.</b> The ppd pointer select bits are used to create an offset into the PPD state memory. The PPD state memory is used to keep track of AAL5 virtual channels for partial packet discard. Up to 8192 virtual channels may be supported with these select fields. The ppd_pnt12_sel[5:0] bits select the most significant bit of the PPD state memory offset, and the ppd_pnt0_sel[5:0] bits select the least significant bit of the offset. A value of zero to 31 selects bits in the cell header where zero is the CLP bit and 31 is the most significant bit of the GFC/VPI field. A value of 32 to 47 selects bits in the tandem routing header where 32 is the least significant bit and 47 is the most significant bit. A value of 48 to 63 selects bits in the cell bus routing header where 48 is the least significant bit and 63 is the most significant bit. The value, "110000," is a special case and may be used to force the value of this bit to '0.' If this bit is forced to zero, the bit position in the resultant pointer is always '0' and is not extracted from the received cell.</p>
ppd_pnt7_sel[5:0]	11:6	RW	X	
Reserved	15:12	RO	0	

14 Registers (continued)

Table 97. PPD Information 5 (PPDI5) (020Eh)

Name	Bit Pos.	Type	Reset	Description
ppd_pnt4_sel[5:0]	5:0	RW	X	<b>PPD Pointer 4 Select.</b> The ppd_pnt4_sel[5:0] bit field selects which bit of the cell header, the cell bus routing header, or the tandem routing header is used as this offset bit.
ppd_pnt5_sel[5:0]	11:6	RW	X	<b>PPD Pointer 5 Select.</b> The ppd_pnt5_sel[5:0] bit field selects which bit of the cell header, the cell bus routing header, or the tandem routing header is used as this offset bit.
				<b>PPD Pointer 4 and 5 Select.</b> The ppd pointer select bits are used to create an offset into the PPD state memory. The PPD state memory is used to keep track of AAL5 virtual channels for partial packet discard. Up to 8192 virtual channels may be supported with these select fields. The ppd_pnt12_sel[5:0] bits select the most significant bit of the PPD state memory offset, and the ppd_pnt0_sel[5:0] bits select the least significant bit of the offset. A value of zero to 31 selects bits in the cell header where zero is the CLP bit and 31 is the most significant bit of the GFC/VPI field. A value of 32 to 47 selects bits in the tandem routing header where 32 is the least significant bit and 47 is the most significant bit. A value of 48 to 63 selects bits in the cell bus routing header where 48 is the least significant bit and 63 is the most significant bit. The value, "110000," is a special case and may be used to force the value of this bit to '0.' If this bit is forced to zero, the bit position in the resultant pointer is always '0' and is not extracted from the received cell.
Reserved	15:12	RO	0	<b>Reserved.</b>

## 14 Registers (continued)

Table 98. PPD Information 6 (PPDI6) (0210h)

Name	Bit Pos.	Type	Reset	Description
ppd_pnt2_sel[5:0]	5:0	RW	X	<b>PPD Pointer 2 Select.</b> The ppd_pnt2_sel[5:0] bit field selects which bit of the cell header, the cell bus routing header, or the tandem routing header is used as this offset bit.
ppd_pnt3_sel[5:0]	11:6	RW	X	<b>PPD Pointer 3 Select.</b> The ppd_pnt3_sel[5:0] bit field selects which bit of the cell header, the cell bus routing header, or the tandem routing header is used as this offset bit.
				<b>PPD Pointer 2 and 3 Select.</b> The ppd pointer select bits are used to create an offset into the PPD state memory. The PPD state memory is used to keep track of AAL5 virtual channels for partial packet discard. Up to 8192 virtual channels may be supported with these select fields. The ppd_pnt12_sel[5:0] bits select the most significant bit of the PPD state memory offset, and the ppd_pnt0_sel[5:0] bits select the least significant bit of the offset. A value of zero to 31 selects bits in the cell header where zero is the CLP bit and 31 is the most significant bit of the GFC/VPI field. A value of 32 to 47 selects bits in the tandem routing header where 32 is the least significant bit and 47 is the most significant bit. A value of 48 to 63 selects bits in the cell bus routing header where 48 is the least significant bit and 63 is the most significant bit. The value, "110000," is a special case and may be used to force the value of this bit to '0.' If this bit is forced to zero, the bit position in the resultant pointer is always '0' and is not extracted from the received cell.
Reserved	15:12	RO	0	<b>Reserved.</b>

## 14 Registers (continued)

Table 99. PPD Information 7 (PPDI7) (0212h)

Name	Bit Pos.	Type	Reset	Description
ppd_pnt0_sel[5:0]	5:0	RW	X	<b>PPD Pointer 0 Select.</b> The ppd_pnt0_sel[5:0] bit field selects which bit of the cell header, the cell bus routing header, or the tandem routing header is used as this offset bit.
ppd_pnt1_sel[5:0]	11:6	RW	X	<b>PPD Pointer 1 Select.</b> The ppd_pnt1_sel[5:0] bit field selects which bit of the cell header, the cell bus routing header, or the tandem routing header is used as this offset bit.
				<b>PPD Pointer 0 and 1 Select.</b> The PPD pointer select bits are used to create an offset into the PPD state memory. The PPD state memory is used to keep track of AAL5 virtual channels for partial packet discard. Up to 8192 virtual channels may be supported with these select fields. The ppd_pnt12_sel[5:0] bits select the most significant bit of the PPD state memory offset, and the ppd_pnt0_sel[5:0] bits select the least significant bit of the offset. A value of zero to 31 selects bits in the cell header where zero is the CLP bit and 31 is the most significant bit of the GFC/VPI field. A value of 32 to 47 selects bits in the tandem routing header where 32 is the least significant bit and 47 is the most significant bit. A value of 48 to 63 selects bits in the cell bus routing header where 48 is the least significant bit and 63 is the most significant bit. The value, "110000," is a special case and may be used to force the value of this bit to '0.' If this bit is forced to zero, the bit position in the resultant pointer is always '0' and is not extracted from the received cell.
Reserved	15:12	RO	0	<b>Reserved.</b>

Table 100. PPD Memory Write (PPDMW) (0418h)

Name	Bit Pos.	Type	Reset	Description
write_pul	0	RW	0	<b>Write Pulse.</b> If a '1' is written to this bit, a single bit will be written to the PPD memory. The value of the bit is obtained from the write_val bit, and the address in the PPD memory is obtained from the write_addr bits. The write_pul bit is cleared by hardware when the write is complete.
write_val	1	RW	0	<b>Write Value.</b> This bit contains the value to be written to the PPD state memory bit.
write_addr	14:2	RW	0	<b>Write Address.</b> These bits contain the address of the bit in PPD memory. This address will be used when a write is performed. This address corresponds to the offset from the cell header, cell bus header, and tandem routing header as determined from the PPD point select bits. An address of all zeros will point to the most significant bit of word 0, and an address of all ones will point to the least significant bit of word 1FF.
Reserved	15	RO	0	<b>Reserved.</b>

## 14 Registers (continued)

### 14.3.2.2 TX UTOPIA Monitoring

**Table 101. PHY Port X Transmit Count Structure (PPXTXCNT) (0600h to 067Ch)**

Name	Offset	Type	Reset	Description
out_cnt_phyX[31:16]	00h	RW	X	<b>Outgoing Cell Count for PHY Port X [31:16].</b> The out_cnt_phyX[31:16] and out_cnt_phyX[15:0] fields together are a free-running counter of cells transmitted on UTOPIA PHY port X.
out_cnt_phyX[15:0]	02h	RW	X	<b>Outgoing Cell Count for PHY Port X [15:0].</b> The out_cnt_phyX[31:16] and out_cnt_phyX[15:0] fields together are a free-running counter of cells transmitted on UTOPIA PHY port X.

The letter X in the data structure name and in the bit names represents the values of 0 through 31 for the 32 PHY ports. The base addresses of the 32 data structures and their associated PHY port number are shown below.

Data Structure	Base Address	Data Structure	Base Address
PHY Port 0 Transmit Count 0	0600h	PHY Port 16 Transmit Count 0	0640h
PHY Port 1 Transmit Count 0	0604h	PHY Port 17 Transmit Count 0	0644h
PHY Port 2 Transmit Count 0	0608h	PHY Port 18 Transmit Count 0	0648h
PHY Port 3 Transmit Count 0	060Ch	PHY Port 19 Transmit Count 0	064Ch
PHY Port 4 Transmit Count 0	0610h	PHY Port 20 Transmit Count 0	0650h
PHY Port 5 Transmit Count 0	0614h	PHY Port 21 Transmit Count 0	0654h
PHY Port 6 Transmit Count 0	0618h	PHY Port 22 Transmit Count 0	0658h
PHY Port 7 Transmit Count 0	061Ch	PHY Port 23 Transmit Count 0	065Ch
PHY Port 8 Transmit Count 0	0620h	PHY Port 24 Transmit Count 0	0660h
PHY Port 9 Transmit Count 0	0624h	PHY Port 25 Transmit Count 0	0664h
PHY Port 10 Transmit Count 0	0628h	PHY Port 26 Transmit Count 0	0668h
PHY Port 11 Transmit Count 0	062Ch	PHY Port 27 Transmit Count 0	066Ch
PHY Port 12 Transmit Count 0	0630h	PHY Port 28 Transmit Count 0	0670h
PHY Port 13 Transmit Count 0	0634h	PHY Port 29 Transmit Count 0	0674h
PHY Port 14 Transmit Count 0	0638h	PHY Port 30 Transmit Count 0	0678h
PHY Port 15 Transmit Count 0	063Ch	PHY Port 31 Transmit Count 0	067Ch

## 14 Registers (continued)

### 14.3.2.3 RX UTOPIA Monitoring

Table 102. PHY Port X Receive Count Structure (PPXRCNT) (0700h to 07F8h)

Name	Offset	Bit Pos.	Type	Reset	Description
in_cnt_phyX[31:16]	00h	15:0	RW	X	<b>Incoming Cell Count for PHY Port X [31:16].</b> The in_cnt_phyX[31:16] and in_cnt_phyX[15:0] fields together are a free-running counter of cells from PHY port X. Both valid and misrouted cells are counted. Incoming cells are not counted if they encounter an Ignore (I) bit in their translation records that is '1' or if their VPI and/or VCI are out of range.
in_cnt_phyX[15:0]	02h	15:0			<b>Incoming Cell Count for PHY Port X [15:0].</b> The in_cnt_phyX[31:16] and in_cnt_phyX[15:0] fields together are a free-running counter of cells from PHY port X. Both valid and misrouted cells are counted. Incoming cells are not counted if they encounter an Ignore (I) bit in their translation records that is '1' or if their VPI and/or VCI are out of range.

The letter X in the data structure name and in the bit names represents the values 0 through 31 for the 32 PHY ports. The base addresses of the 32 data structures are shown below.

Structure Name	Base Address	Structure Name	Base Address
PHY port 0 receive count 0	0700h	PHY port 16 receive count 0	0780h
PHY port 1 receive count 0	0708h	PHY port 17 receive count 0	0788h
PHY port 2 receive count 0	0710h	PHY port 18 receive count 0	0790h
PHY port 3 receive count 0	0718h	PHY port 19 receive count 0	0798h
PHY port 4 receive count 0	0720h	PHY port 20 receive count 0	07A0h
PHY port 5 receive count 0	0728h	PHY port 21 receive count 0	07A8h
PHY port 6 receive count 0	0730h	PHY port 22 receive count 0	07B0h
PHY port 7 receive count 0	0738h	PHY port 23 receive count 0	07B8h
PHY port 8 receive count 0	0740h	PHY port 24 receive count 0	07C0h
PHY port 9 receive count 0	0748h	PHY port 25 receive count 0	07C8h
PHY port 10 receive count 0	0750h	PHY port 26 receive count 0	07D0h
PHY port 11 receive count 0	0758h	PHY port 27 receive count 0	07D8h
PHY port 12 receive count 0	0760h	PHY port 28 receive count 0	07E0h
PHY port 13 receive count 0	0768h	PHY port 29 receive count 0	07E8h
PHY port 14 receive count 0	0770h	PHY port 30 receive count 0	07F0h
PHY port 15 receive count 0	0778h	PHY port 31 receive count 0	07F8h

## 14 Registers (continued)

Table 103. LUT X Configuration 1 Structure (LUTXCF1) (0704h to 077Ch)

Name	Offset	Bit Pos.	Type	Reset	Description
lutX_vpi_base	00h	15:0	RW	X	<p><b>LUT X VPI Base Address.</b> These bits define bits 3 through 18 of the VPI base address offset in look-up table X. The offset may be a maximum of 19 bits. If 16-byte records are used, the least significant bit of this word is ignored.</p> <p><b>Note:</b> When 16 or less PHY ports are used, each PHY port has its own look-up table memory space. For 16 or less PHY ports, PHY port 0 uses LUT 0 memory space, PHY port 1 uses LUT 1 memory space, and so on. When greater than 16 PHY ports are used, even and odd PHY ports must share the look-up memory space. For greater than 16 PHY ports, PHY ports 0 and 1 use LUT 0 memory space, PHY ports 2 and 3 use LUT 1 memory space, PHY ports 4 and 5 use LUT 2 memory space, and so on.</p>
lutX_vpi_mask	02h	11:0			<p><b>LUT X VPI Mask.</b> This 12-bit field is used to mask the incoming VPI bits. If a bit in the field is set to '1,' the corresponding incoming VPI bit will be used to address the VPI record in the look-up table. All other incoming VPI bits will be ignored.</p>
lutX_vpi_chk		12			<p><b>LUT X VPI Check.</b> If this bit is set to '1,' the unused incoming VPI bits must be '0,' or the cell will be counted as misrouted. Unused bits are bits whose corresponding lutX_vpi_mask bit equal zero.</p>
lutX_uni_en		13			<p><b>LUT X User Network Interface (UNI) Enable.</b> If this bit is set to '1,' the port is identified as UNI, and the GFC field of the cell header will not be used in the look-up table. If this bit is '0,' the port is identified as NNI.</p>
Reserved		15:14			<p><b>Reserved.</b></p>

The letter X in the data structure name and in the bit names represents the values 0 through 15 for the 16 look-up table configurations. The base addresses of the 16 data structures are shown below.

Structure Name	Base Address	Structure Name	Base Address
LUT 0 configuration 1	0704h	LUT 8 configuration 1	0744h
LUT 1 configuration 1	070Ch	LUT 9 configuration 1	074Ch
LUT 2 configuration 1	0714h	LUT 10 configuration 1	0754h
LUT 3 configuration 1	071Ch	LUT 11 configuration 1	075Ch
LUT 4 configuration 1	0724h	LUT 12 configuration 1	0764h
LUT 5 configuration 1	072Ch	LUT 13 configuration 1	076Ch
LUT 6 configuration 1	0734h	LUT 14 configuration 1	0774h
LUT 7 configuration 1	073Ch	LUT 15 configuration 1	077Ch

## 14 Registers (continued)

### 14.3.3 SDRAM Registers

Table 104. SDRAM Control (SCT) (0400h)

Name	Bit Pos.	Type	Reset	Description
sdram_en	0	RW	0	<b>SDRAM Enable.</b> If this bit is set to '1,' the SDRAM becomes active. If '0,' the SDRAM is in the idle state.
gen_man_acc	1	WO	0	<b>Generate Manual Access.</b> If the sdram_en bit is '0,' writing a '1' to this bit will take the SDRAM out of its idle state and activate the manual values programmed in the cas_man, ras_man, we_man, bs_man, and addr_man bits. The '1' pulses for one clock cycle and clears to '0' automatically. The SDRAM then returns to its idle state. This special mode is used in the start-up sequence for the SDRAM.
Reserved	14:2	RO	0	<b>Reserved.</b>
Reserved	15	RW	0	<b>Reserved.</b> Program this bit to '0.'

Table 105. SDRAM Interrupt Status (SIS) (0402h)

Name	Bit Pos.	Type	Reset	Description
ref_late	0	ROL	0	<b>Refresh Late.</b> This bit is set when the refresh cycle for the SDRAM is greater than the value programmed in the late_lim bits. An interrupt is generated if the corresponding enable bit is set.
crc8_err_even	1	ROL	0	<b>CRC-8 Error on Even Data Byte.</b> This bit is set when an error is detected on the even byte (sd_d[15:8]) of the SDRAM data bus. An interrupt is generated if the corresponding enable bit is set.
crc8_err_odd	2	ROL	0	<b>CRC-8 Error on Odd Data Byte.</b> This bit is set when an error is detected on the odd byte (sd_d[7:0]) of the SDRAM data bus. An interrupt is generated if the corresponding enable bit is set.
Reserved	15:3	RO	0	<b>Reserved.</b>

Table 106. SDRAM Interrupt Enable (SIE) (0404h)

Name	Bit Pos.	Type	Reset	Description
ref_late_ie	0	RW	0	<b>Refresh Late Interrupt Enable.</b> An interrupt is generated if this bit and the corresponding status bit are set. The interrupt is generated until this bit or the corresponding status bit is reset.
crc8_err_even_ie	1	RW	0	<b>CRC-8 Error on Even Data Byte Interrupt Enable.</b> An interrupt is generated if this bit and the corresponding status bit are set. The interrupt is generated until this bit or the corresponding status bit is reset.
crc8_err_odd_ie	2	RW	0	<b>CRC-8 Error on Odd Data Byte Interrupt Enable.</b> An interrupt is generated if this bit and the corresponding status bit are set. The interrupt is generated until this bit or the corresponding status bit is reset.
Reserved	15:3	RO	0	<b>Reserved.</b>



## 14 Registers (continued)

Table 107. SDRAM Configuration (SCF) (0408h)

Name	Bit Pos.	Type	Reset	Description
col_num	1:0	RW	0	<b>Column Number.</b> These bits are used to indicate the number of columns in the SDRAM. "100" = 256 columns "01" = 512 columns "10" = 1024 columns "11" = reserved
cas_lat	2	RW	0	<b>CAS Latency.</b> This bit is used to indicate the CAS latency of the SDRAM based on the clock frequency and speed grade of the device. '0' = 2 cycles '1' = 3 cycles
ras2cas	4:3	RW	2h	<b>RAS Inactive to CAS Active Delay.</b> These bits specify the minimum time in SDRAM clock cycles from RAS going inactive to CAS going active. "01" = reserved "10" = 2 clock cycles "11" = 3 clock cycles "00" = 4 clock cycles
cas2pre	6:5	RW	1	<b>CAS Inactive to Precharge Active Delay.</b> These bits specify the minimum time in SDRAM clock cycles from CAS going inactive to the precharge command going active. "01" = 1 clock cycles "10" = 2 clock cycles "11" = 3 clock cycles "00" = 4 clock cycles
pre2cmd	8:7	RW	2h	<b>Precharge Inactive to Next Command Active Delay.</b> These bits specify the minimum time in SDRAM clock cycles from the precharge command going inactive to next command going active. "01" = 1 clock cycles "10" = 2 clock cycles "11" = 3 clock cycles "00" = 4 clock cycles
ref2cmd	10:9	RW	0	<b>CBR Refresh Inactive to Next CBR Refresh Command Active Delay.</b> These bits specify the minimum time in SDRAM clock cycles from the refresh command going inactive to next refresh command going active. The minimum time from the refresh command to any other command is 15 clock cycles. "00" = 15 clock cycles "01" = reserved "10" = 3 clock cycles "11" = 7 clock cycles
Reserved	15:11	RO	0	<b>Reserved.</b>

## 14 Registers (continued)

Table 108. Refresh (RFRSH) (0410h)

Name	Bit Pos.	Type	Reset	Description
ref_cnt	15:0	RW	0400h	<b>Refresh Count.</b> These bits are used to program the refresh cycle in SDRAM clock cycles. The number of clock cycles programmed in this register should be less than one half the worst-case refresh period.

Table 109. Refresh Lateness (RFRSHL) (0412h)

Name	Bit Pos.	Type	Reset	Description
late_lim	15:0	RW	0400h	<b>Lateness Limit.</b> These bits are used to program how late a refresh cycle may occur. This limit is in refresh cycles. When this limit is reached, the ref_late status bit will be set.

Table 110. Idle State 1 (IS1) (0420h)

Name	Bit Pos.	Type	Reset	Description
cas_idle	0	RW	1	<b>SDRAM CAS Idle Value.</b> This is the value that will be placed on the sd_cas* pin while the SDRAM is idle (sdram_en = '0').
ras_idle	1	RW	1	<b>SDRAM RAS Idle Value.</b> This is the value that will be placed on the sd_ras* pin while the SDRAM is idle (sdram_en = '0').
we_idle	2	RW	1	<b>SDRAM Write Enable Idle Value.</b> This is the value that will be placed on the sd_we* pin while the SDRAM is idle (sdram_en = '0').
bs_idle[1:0]	4:3	RW	3h	<b>SDRAM Bank Select Idle Value.</b> This is the value that will be placed on the sd_bs[1:0] pins while the SDRAM is idle (sdram_en = '0').
Reserved	15:5	RO	0	<b>Reserved.</b>

Table 111. Idle State 2 (IS2) (0422h)

Name	Bit Pos.	Type	Reset	Description
addr_idle[11:0]	11:0	RW	0	<b>SDRAM Address Idle Value.</b> This is the value that will be placed on the sd_a[11:0] pins while the SDRAM is idle (sdram_en = '0').
Reserved	15:12	RO	0	<b>Reserved.</b>

## 14 Registers (continued)

**Table 112. Manual Access State 1 (MAS1) (0424h)**

Name	Bit Pos.	Type	Reset	Description
cas_man	0	RW	1	<b>SDRAM CAS Manual Value.</b> This is the value that will be placed on the sd_cas* pin for one clock cycle when the gen_man_acc bit is written to '1.'
ras_man	1	RW	1	<b>SDRAM RAS Manual Value.</b> This is the value that will be placed on the sd_ras* pin for one clock cycle when the gen_man_acc bit is written to '1.'
we_man	2	RW	1	<b>SDRAM Write Enable Manual Value.</b> This is the value that will be placed on the sd_we* pin for one clock cycle when the gen_man_acc bit is written to '1.'
bs_man[1:0]	4:3	RW	3h	<b>SDRAM Band Select Manual Value.</b> This is the value that will be placed on the sd_bs[1:0] pins for one clock cycle when the gen_man_acc bit is written to '1.'
Reserved	15:5	RO	0	<b>Reserved.</b>

**Table 113. Manual Access State 2 (MAS2) (0426h)**

Name	Bit Pos.	Type	Reset	Description
addr_man[11:0]	11:0	RW	0	<b>SDRAM Address Manual Value.</b> This is the value that will be placed on the sd_a[11:0] pins for one clock cycle when the gen_man_acc bit is written to '1.'
Reserved	15:12	RO	0	<b>Reserved.</b>

## 14 Registers (continued)

**Table 114. SDRAM Interrupt Service Request 4 (SISR4) (0438h)**

Name	Bit Pos.	Type	Reset	Description
queue_serv[63:48]	15:0	RO	0	<b>Queue Service [63:48].</b> Each bit in this field represents one of 16 queue X registers from the 64 queue X registers. The least significant bit represents the queue 48 register. The most significant bit represents the queue 63 register. If the corresponding bit is '1,' the specific queue X register has interrupt status bits that need servicing (see Table 118).

**Table 115. SDRAM Interrupt Service Request 3 (SISR3) (043Ah)**

Name	Bit Pos.	Type	Reset	Description
queue_serv[47:32]	15:0	RO	0	<b>Queue Service [47:32].</b> Each bit in this field represents one of 16 queue X registers from the 64 queue X registers. The least significant bit represents the queue 32 register. The most significant bit represents the queue 47 register. If the corresponding bit is '1,' the specific queue X register has interrupt status bits that need servicing (see Table 118).

**Table 116. SDRAM Interrupt Service Request 1 (SISR1) (043Ch)**

Name	Bit Pos.	Type	Reset	Description
queue_serv[31:16]	15:0	RO	0	<b>Queue Service [31:16].</b> Each bit in this field represents one of 16 queue X registers from the 64 queue X registers. The least significant bit represents the queue 16 register. The most significant bit represents the queue 31 register. If the corresponding bit is '1,' the specific queue X register has interrupt status bits that need servicing (see Table 118).

**Table 117. SDRAM Interrupt Service Request 2 (SISR2) (043Eh)**

Name	Bit Pos.	Type	Reset	Description
queue_serv[15:0]	15:0	RO	0	<b>Queue Service [15:0].</b> Each bit in this field represents one of 16 queue X registers from the 64 queue X registers. The least significant bit represents the queue 0 register. The most significant bit represents the queue 15 register. If the corresponding bit is '1,' the specific queue X register has interrupt status bits that need servicing (see Table 118).

## 14 Registers (continued)

Table 118. Queue X (QX) (0440h to 04BEh)

Name	Bit Pos.	Type	Reset	Description
queueX_rd_en	0	RW	0	<b>Queue X Read Enable.</b> If this bit is '1,' the queue is enabled for read operations. When any configuration bits are changed, this bit must be '0.' <b>Note:</b> To prevent corruption of data, this bit must be cleared in unused queues.
queueX_wr_en	1	RW	0	<b>Queue X Write Enable.</b> If this bit is '1,' the queue is enabled for write operations. When any configuration bits are changed, this bit must be '0.' <b>Note:</b> To prevent corruption of data, this bit must be cleared in unused queues.
queueX_fecn_en	2	RW	0	<b>Queue X FECN Enable.</b> If this bit is '1,' the forward explicit congestion notification (FECN) feature is enabled.
queueX_clp_en	3	RW	0	<b>Queue X CLP Enable.</b> If this bit is '1,' the cell loss priority (CLP) feature is enabled.
Reserved	7:4	RO	0	<b>Reserved.</b>
queueX_fecn_lim	8	ROL	0	<b>Queue X FECN Limit Reached.</b> This bit is set when the FECN limit has been reached in the queue. An interrupt is generated if the corresponding enable bit is set.
queueX_clp_lim	9	ROL	0	<b>Queue X CLP Limit Reached.</b> This bit is set when the CLP limit has been reached in the queue. An interrupt is generated if the corresponding enable bit is set.
queueX_ovrn	10	ROL	0	<b>Queue X Overrun.</b> This bit is set when the queue overruns. An interrupt is generated if the corresponding enable bit is set.
queueX_emp	11	ROL	0	<b>Queue X Empty.</b> This bit is set when the queue is empty. An interrupt is generated if the corresponding enable bit is set.
queueX_fecn_lim_ie	12	RW	0	<b>Queue X FECN Limit Reached Interrupt Enable.</b> An interrupt is generated if this bit and the corresponding status bit are set. The interrupt is generated until this bit or the corresponding status bit is reset.
queueX_clp_lim_ie	13	RW	0	<b>Queue X CLP Limit Reached Interrupt Enable.</b> An interrupt is generated if this bit and the corresponding status bit are set. The interrupt is generated until this bit or the corresponding status bit is reset.
queueX_ovrn_ie	14	RW	0	<b>Queue X Overrun Interrupt Enable.</b> An interrupt is generated if this bit and the corresponding status bit are set. The interrupt is generated until this bit or the corresponding status bit is reset.

## 14 Registers (continued)

Table 118. Queue X (QX) (0440h to 04BEh) (continued)

Name	Bit Pos.	Type	Reset	Description
queueX_emp_ie	15	RW	0	<b>Queue X Empty Interrupt Enable.</b> An interrupt is generated if this bit and the corresponding status bit are set. The interrupt is generated until this bit or the corresponding status bit is reset.

The letter X in the register name and in the bit names represents the values of 0 through 63 for the 64 queues shown below.

Register Name	Register Address	Register Name	Register Address	Register Name	Register Address	Register Name	Register Address
Queue 0 (Q0)	0440h	Queue 16 (Q16)	0460h	Queue 32 (Q32)	0480h	Queue 48 (Q48)	04A0h
Queue 1 (Q1)	0442h	Queue 17 (Q17)	0462h	Queue 33 (Q33)	0482h	Queue 49 (Q49)	04A2h
Queue 2 (Q2)	0444h	Queue 18 (Q18)	0464h	Queue 34 (Q34)	0484h	Queue 50 (Q50)	04A4h
Queue 3 (Q3)	0446h	Queue 19 (Q19)	0466h	Queue 35 (Q35)	0486h	Queue 51 (Q51)	04A6h
Queue 4 (Q4)	0448h	Queue 20 (Q20)	0468h	Queue 36 (Q36)	0488h	Queue 52 (Q52)	04A8h
Queue 5 (Q5)	044Ah	Queue 21 (Q21)	046Ah	Queue 37 (Q37)	048Ah	Queue 53 (Q53)	04AAh
Queue 6 (Q6)	044Ch	Queue 22 (Q22)	046Ch	Queue 38 (Q38)	048Ch	Queue 54 (Q54)	04ACh
Queue 7 (Q7)	044Eh	Queue 23 (Q23)	046Eh	Queue 39 (Q39)	048Eh	Queue 55 (Q55)	04AEh
Queue 8 (Q8)	0450h	Queue 24 (Q24)	0470h	Queue 40 (Q40)	0490h	Queue 56 (Q56)	04B0h
Queue 9 (Q9)	0452h	Queue 25 (Q25)	0472h	Queue 41 (Q41)	0492h	Queue 57 (Q57)	04B2h
Queue 10 (Q10)	0454h	Queue 26 (Q26)	0474h	Queue 42 (Q42)	0494h	Queue 58 (Q58)	04B4h
Queue 11 (Q11)	0456h	Queue 27 (Q27)	0476h	Queue 43 (Q43)	0496h	Queue 59 (Q59)	04B6h
Queue 12 (Q12)	0458h	Queue 28 (Q28)	0478h	Queue 44 (Q44)	0498h	Queue 60 (Q60)	04B8h
Queue 13 (Q13)	045Ah	Queue 29 (Q29)	047Ah	Queue 45 (Q45)	049Ah	Queue 61 (Q61)	04BAh
Queue 14 (Q14)	045Ch	Queue 30 (Q30)	047Ch	Queue 46 (Q46)	049Ch	Queue 62 (Q62)	04BCh
Queue 15 (Q15)	045Eh	Queue 31 (Q31)	047Eh	Queue 47 (Q47)	049Eh	Queue 63 (Q63)	04BEh

**Note:** When the T8207\_sel bit = 0, queues 32—63 are disabled (default).

## 14 Registers (continued)

### 14.3.3.1 SDRAM Control Memory

Table 119. Queue X Definition Structure (QXDEF) (2000h to 27E0h)

Name	Offset	Bit Pos.	Type	Reset	Description
base_addrX[24:9]	00h	15:0	RW	X	<b>Base Address Queue X [24:9].</b> These bits configure the upper 16 bits of the queue's base address offset in increments of one cell (64 bytes).
base_addrX[8:6]	02h	15:13	RW		<b>Base Address Queue X [8:6].</b> These bits configure bits 6 through 8 of the queue's base address offset in increments of one cell (64 bytes).
Reserved		12:0	RO		<b>Reserved.</b>
end_addrX[24:9]	04h	15:0	RW		<b>End Address Queue X [24:9].</b> These bits configure the upper 16 bits of the queue's end address offset in increments of one cell. The total number of cells held by the queue may be calculated by subtracting the base_addr from the end_addr and adding one to the difference. The minimum size of any queue is four cells.
end_addrX[8:6]	06h	15:13	RW		<b>End Address Queue X [8:6].</b> These bits configure bits 6 through 8 of the queue's end address offset in increments of one cell. The total number of cells held by the queue may be calculated by subtracting the base_addr from the end_addr and adding one to the difference. The minimum size of any queue is four cells.
Reserved		12:0	RO		<b>Reserved.</b>
wr_pntX[24:9]	08h	15:0	RW		<b>Write Pointer for Queue X [24:9].</b> These bits must be initialized to the base_addrX[24:9] before the queue is enabled.
wr_pntX[8:6]	0Ah	15:13	RW		<b>Write Pointer for Queue X [8:6].</b> These bits must be initialized to the base_addrX[8:6] before the queue is enabled.
Reserved		12:0	RO		<b>Reserved.</b>
rd_pntX[24:9]	0Ch	15:0	RW		<b>Read Pointer for Queue X [24:9].</b> These bits must be initialized to the base_addrX[24:9] before the queue is enabled.
rd_pntX[8:6]	0Eh	15:13	RW		<b>Read Pointer for Queue X [8:6].</b> These bits must be initialized to the base_addrX[8:6] before the queue is enabled.
Reserved		12:0	RO		<b>Reserved.</b>
fecn_fillX[24:9]	10h	15:0	RW	X	<b>FECN Fill for Queue X [24:9].</b> These bits with fecn_fillX[8:6] determine the queue's fill level in cells (64 bytes) where the FECN bit is set in outgoing cells. The FECN bit is set only when the queueX_fecn_en bit is '1.'
fecn_fillX[8:6]	12h	15:13	RW		<b>FECN Fill for Queue X [8:6].</b> These bits with fecn_fillX[24:9] determine the queue's fill level in cells (64 bytes) where the FECN bit is set in outgoing cells. The FECN bit is set only when the queueX_fecn_en bit is '1.'
Reserved		12:0	RO		<b>Reserved.</b>
clp_fillX[24:9]	14h	15:0	RW		<b>CLP Fill for Queue X [24:9].</b> These bits with clp_fillX[8:6] determine the queue's fill level in cells (64 bytes) where incoming cells with their CLP bit set will be discarded. The incoming cell is dropped at this fill level only when the queueX_clp_en bit is '1.'
clp_fillX[8:6]	16h	15:13	RW		<b>CLP Fill for Queue X [8:6].</b> These bits with clp_fillX[24:9] determine the queue's fill level in cells (64 bytes) where incoming cells with their CLP bit set will be discarded. The incoming cell is dropped at this fill level only when the queueX_clp_en bit is '1.'
Reserved		12:0	RO		<b>Reserved.</b>

**14 Registers** (continued)

**Table 119. Queue X Definition Structure (QXDEF) (2000h to 27E0h)** (continued)

Name	Offset	Bit Pos.	Type	Reset	Description
The letter X in the data structure name and in the bit names represents the values of 0 through 63 for the 64 queues shown below.					
Structure Name		Base Address		Structure Name	
Queue 0 base address high		2000h		Queue 32 base address high	
Queue 1 base address high		2020h		Queue 33 base address high	
Queue 2 base address high		2040h		Queue 34 base address high	
Queue 3 base address high		2060h		Queue 35 base address high	
Queue 4 base address high		2080h		Queue 36 base address high	
Queue 5 base address high		20A0h		Queue 37 base address high	
Queue 6 base address high		20C0h		Queue 38 base address high	
Queue 7 base address high		20E0h		Queue 39 base address high	
Queue 8 base address high		2100h		Queue 40 base address high	
Queue 9 base address high		2120h		Queue 41 base address high	
Queue 10 base address high		2140h		Queue 42 base address high	
Queue 11 base address high		2160h		Queue 43 base address high	
Queue 12 base address high		2180h		Queue 44 base address high	
Queue 13 base address high		21A0h		Queue 45 base address high	
Queue 14 base address high		21C0h		Queue 46 base address high	
Queue 15 base address high		21E0h		Queue 47 base address high	
Queue 16 base address high		2200h		Queue 48 base address high	
Queue 17 base address high		2220h		Queue 49 base address high	
Queue 18 base address high		2240h		Queue 50 base address high	
Queue 19 base address high		2260h		Queue 51 base address high	
Queue 20 base address high		2280h		Queue 52 base address high	
Queue 21 base address high		22A0h		Queue 53 base address high	
Queue 22 base address high		22C0h		Queue 54 base address high	
Queue 23 base address high		22E0h		Queue 55 base address high	
Queue 24 base address high		2300h		Queue 56 base address high	
Queue 25 base address high		2320h		Queue 57 base address high	
Queue 26 base address high		2340h		Queue 58 base address high	
Queue 27 base address high		2360h		Queue 59 base address high	
Queue 28 base address high		2380h		Queue 60 base address high	
Queue 29 base address high		23A0h		Queue 61 base address high	
Queue 30 base address high		23C0h		Queue 62 base address high	
Queue 31 base address high		23E0h		Queue 63 base address high	



## 14 Registers (continued)

### 14.3.4 Various Internal Memories

#### 14.3.4.1 Control Cell Memories

**Table 120. Control Cell Receive Extended Memory (CCRXEM) (0800h to 0832h)**

The control cell receive memory may also be accessed from direct memory. See Table 50.

Name	Offset	Type	Reset	Description
header[31:16]	00h	RO	X	These 52 bytes are the control cell received from the cell bus. When present, the control cell may be read from this extended memory space.
header[15:0]	02h			
payload_bytes 0—1	04h			
.	.			
.	.			
payload_bytes 46—47	32h			

**Table 121. Control Cell Transmit Extended Memory (CCTXEM) (0900h to 0936h)**

The control cell transmit memory may also be accessed from direct memory. See Table 51.

Name	Offset	Type	Reset	Description
cell_bus_routing_header	0	RW	X	These 56 bytes are the cell routing header, the tandem routing header, and the control cell to be transmitted onto the cell bus. A control cell to be transmitted may be written to this extended memory space.
tandem_routing_header	2			
header[31:16]	4			
header[15:0]	6			
payload_bytes 0—1	8			
.	.			
.	.			
payload_bytes 46—47	36h			

**14 Registers** (continued)

**14.3.4.2 Multicast Number Memories**

**Table 122. PHY Port 0 and Control Cells Multicast Extended Memory (PP0MEM) (0C00h to 0C1Eh)**

The PHY port 0 and control cells multicast memory may also be accessed from direct memory (see Table 52).

<b>Name</b>	<b>Offset</b>	<b>Type</b>	<b>Reset</b>	<b>Description</b>
multicast_receive_enable[15:0]	00h	RW	X	This memory space contains 256 active-high enable bits. Each bit represents a multicast net number from 0 through 255. If a bit is set, the corresponding multicast net number data cell is sent to the queue group for PHY port 0, or the corresponding multicast control cell is sent to the control cell receive direct and extended memory. The least significant bit is multicast net number 0.
multicast_receive_enable[31:16]	02h			
multicast_receive_enable[47:32]	04h			
.	.			
.	.			
.	.			
multicast_receive_enable[191:176]	16h			
multicast_receive_enable[207:192]	18h			
multicast_receive_enable[223:208]	1Ah			
multicast_receive_enable[239:224]	1Ch			
multicast_receive_enable[255:240]	1Eh			

## 14 Registers (continued)

**Table 123. PHY Port X Multicast Memory (PPXMM) (0C20h to 0DE0h)**

Name	Offset	Type	Reset	Description
multicast_receive_enable[15:0]	00h	RW	X	This memory space contains 256 active-high enable bits. Each bit represents a multicast net number from 0 through 255. If a bit is set, the corresponding multicast net number data cell is sent to the queue group for PHY port X. The least significant bit is multicast net number 0.
multicast_receive_enable[31:16]	02h			
multicast_receive_enable[47:32]	04h			
.	.			
.	.			
.	.			
multicast_receive_enable[239:224]	1Ch			
multicast_receive_enable[255:240]	1Eh			

The letter X in the data structure and in the bit names represents the values of 1 through 15 for 15 of the 16 PHY ports. The base addresses of the 15 multicast memory locations are shown below.

Memory Name	Base Address
PHY Port 1 Multicast Memory	0C20h
PHY Port 2 Multicast Memory	0C40h
PHY Port 3 Multicast Memory	0C60h
PHY Port 4 Multicast Memory	0C80h
PHY Port 5 Multicast Memory	0CA0h
PHY Port 6 Multicast Memory	0CC0h
PHY Port 7 Multicast Memory	0CE0h
PHY Port 8 Multicast Memory	0D00h
PHY Port 9 Multicast Memory	0D20h
PHY Port 10 Multicast Memory	0D40h
PHY Port 11 Multicast Memory	0D60h
PHY Port 12 Multicast Memory	0D80h
PHY Port 13 Multicast Memory	0DA0h
PHY Port 14 Multicast Memory	0DC0h
PHY Port 15 Multicast Memory	0DE0h

**Note:** When the T8207\_sel bit = '0' multicast memory at address 0D00h—0DECh are ignored.

**14 Registers** (continued)

**14.3.4.3 PPD State Memory**

**Table 124. PPD Memory (PPDM) (1000h to 13FEh)**

Name	Offset	Type	Reset	Description
word0	00h	RW	X	This memory space contains 8192 AAL5 virtual channel PPD bits. The PPD pointer bits in the cell header, cell bus routing header, and tandem routing header, which are selected by the PPD pointer select bits, point to a single bit in this memory space. If the bit for a corresponding AAL5 virtual channel is '0,' no cells are dropped. If the bit is '1,' all remaining cells in the packet, except the last cell, are dropped. A PPD bit becomes set when a cell in an AAL5 virtual channel packet is dropped. The last cell of a packet is identified by the least significant bit of the PTI field in the cell header, which is set to '1.' The most significant bit of the PTI field is also checked to be '0' (user data). The final cell of the packet is sent, and the corresponding PPD bit is cleared. The most significant bit of word0 corresponds to AAL5 virtual channel zero, and the least significant bit of word1FF corresponds to AAL5 virtual channel 8191.
word1	02h			
word2	04h			
word3	06h			
word4	08h			
word5	0Ah			
word6	0Ch			
word7	0Eh			
.	.			
.	.			
.	.			
word1F9	3F2h			
word1FA	3F4h			
word1FB	3F6h			
word 1FC	3F8h			
word1FD	3FAh			
word1FE	3FCh			
word1FF	3FEh			

## 14 Registers (continued)

### 14.3.5 External Memories

#### 14.3.5.1 Look-Up Translation Memory

Table 125. Translation RAM Memory (TRAM) (100000h to 17FFFEh)

Name	Offset	Type	Reset	Description
word0	00h	RW	X	This memory space is used to access the translation RAM memory.
.	.			
word3FFFF	7FFFEh			

#### 14.3.5.2 SDRAM Buffer Memory

Table 126. SDRAM (SDRAM) (2000000h to 3FFFFFFEh)

Name	Offset	Type	Reset	Description
word0	00h	RW	X	This memory space is used to access the SDRAM memory.
.	.			
wordFFFFFFE	1FFFFFFEh			

## 15 Absolute Maximum Ratings

Stresses in excess of the absolute maximum ratings can cause permanent damage to the device. These are absolute stress ratings only. Functional operation of the device is not implied at these or any other conditions in excess of those given in the operational sections of the data sheet. Exposure to absolute maximum ratings for extended periods can adversely affect device reliability.

**Table 127. Maximum Rating Parameters and Values**

Parameter	Symbol	Min	Typ	Max	Unit
dc Supply Voltage with Respect to Ground	V <sub>DD</sub>	—	—	4.2	V
Input Voltage Range <sup>1</sup>	V <sub>I1</sub>	V <sub>SS</sub> – 0.3	—	V <sub>DD</sub> + 0.3	V
Junction Temperature Range	T <sub>J</sub>	–40	—	125	°C
Storage Temperature	T <sub>stg</sub>	–60	—	160	°C
Maximum Power Dissipation (package limit) <sup>2</sup>	P <sub>D</sub>	—	—	2.44	W

1. Except for 5 V tolerant buffers where V<sub>IHmax</sub> = 5.5 V + 0.3 V.

2. Maximum power dissipation may be determined from the following equation: P<sub>D</sub> = (125 °C – T<sub>A</sub>)/22.5 °C/W.

## 16 Recommended Operating Conditions

**Table 128. Recommended Operating Conditions**

Parameter	Symbol	Min	Typ	Max	Unit
dc Supply Voltage with Respect to Ground	V <sub>DD</sub>	3.0	—	3.6	V
Ambient Operating Temperature Range	T <sub>A</sub>	–40	—	85	°C

## 17 Handling Precautions

Although protection circuitry has been designed into this device, proper precautions should be taken to avoid exposure to electrostatic discharge (ESD) during handling and mounting. Agere employs a human-body model (HBM) and a charged-device model (CDM) for ESD-susceptibility testing and protection design evaluation. ESD voltage thresholds are dependent on the circuit parameters used to define the model. No industry-wide standard has been adopted for the CDM. A standard HBM (resistance = 1500 Ω, capacitance = 100 pF) is widely accepted and can be used for comparison. The HBM ESD threshold presented here was obtained by using these circuit parameters.

**Table 129. HBM ESD Threshold**

Device	Voltage (V)
T8207	2000

## 18 Electrical Requirements and Characteristics

### 18.1 Crystal Information

The *CelXpres* T8207 device requires a crystal or external clock source. The crystal may have a frequency from 5 MHz to 40 MHz and is connected between *xtalin* and *xtalout*. External 5% capacitors must be connected from *xtalin* and *xtalout* to *Vss*. The value of the external capacitors is determined from the crystal data sheet using the crystal specification requirements shown below.

**Table 130. Crystal Specifications**

Parameter	Value
Frequency	5 MHz to 40 MHz
Oscillation Mode	Fundamental parallel resonant
Effective Series Resistance	See Figure 20 below
Frequency Tolerance and Stability	5%

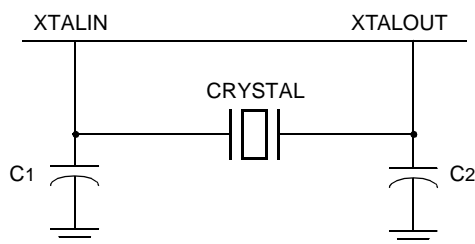

**Figure 19. Crystal**

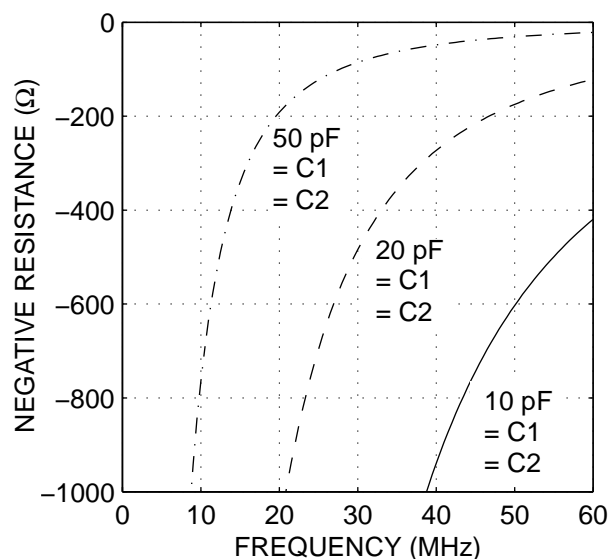

**Figure 20. Negative Resistance Plot**

The *xtalin* input may be driven by an external clock instead of a crystal. The frequency of the external source may be 5 MHz to 50 MHz. The external clock must meet the requirements shown below.

**Table 131. External Clock Requirements**

Parameter	Min	Max
Frequency	5 MHz	50 MHz
Maximum Rise or Fall Time	—	5 ns
Duty Cycle	40%	60%

The frequency of the T8207's main clock (*mclk*) is derived from the clock at the *xtalin* input (*pclk*). See Section 5, PLL Configuration, for more information on these clocks.

**18 Electrical Requirements and Characteristics** (continued)

**18.2 dc Electrical Characteristics**

The following conditions apply except where noted:  $T_A = -40\text{ }^\circ\text{C}$  to  $+85\text{ }^\circ\text{C}$ ,  $V_{DD} = 3.3\text{ V} \pm 10\%$ , 15 pF each output.

**Table 132. dc Electrical Characteristics**

Parameter	Symbol	Test Conditions	Min	Typ	Max	Unit
Supply Current	$I_{DD}$	—	—	—	—	mA
Input Voltage (TTL):						
Low	$V_{IL}$	—	—	—	0.8	V
High	$V_{IH}$	—	2.0	—	—	V
Input Voltage (TTL 5 V tolerant):						
Low	$V_{IL}$	—	—	—	0.8	V
High	$V_{IH}$	—	2.0	—	5.5	V
Input Voltage (GTL+):						
Low	$V_{IL}$	—	—	—	0.8	V
High	$V_{IH}$	—	1.2	—	—	V
Input Voltage (xtalin):						
Low	$V_{IL}$	—	—	—	$0.2 V_{DD}$	V
High	$V_{IH}$	—	$0.7 V_{DD}$	—	—	V
Output Voltage (TTL 4 mA):						
Low	$V_{OL}$	$I_{OL} = 4\text{ mA}$	—	—	0.4	V
High	$V_{OH}$	$I_{OH} = -4\text{ mA}$	2.4	—	—	V
Output Voltage (TTL 6 mA):						
Low	$V_{OL}$	$I_{OL} = 6\text{ mA}$	—	—	0.4	V
High	$V_{OH}$	$I_{OH} = -6\text{ mA}$	2.4	—	—	V
Output Voltage (TTL 7 mA):						
Low	$V_{OL}$	$I_{OL} = 7\text{ mA}$	—	—	0.4	V
High	$V_{OH}$	$I_{OH} = -7\text{ mA}$	2.4	—	—	V
Output Voltage (TTL 10 mA):						
Low	$V_{OL}$	$I_{OL} = 10\text{ mA}$	—	—	0.4	V
High	$V_{OH}$	$I_{OH} = -10\text{ mA}$	2.4	—	—	V
Output Current (GTL+)	$I_{OL}$	—	65	—	75	mA
Output Voltage (GTL+)	$V_{OL}$	—	—	0.3	0.5	V
Input Leakage Current (TTL)	—	—	—	—	1	$\mu\text{A}$
Input Leakage Current (TTL with pull-ups)	—	$V_{IL} = V_{SS}$	—	—	67	$\mu\text{A}$
Input Leakage Current (cb_vref)	—	—	—	—	40	$\mu\text{A}$
Power Dissipation	$P_D$	—	—	—	1.5*	W

\* This is the power consumed by the device under the following conditions:  $V_{DD} = 3.3\text{ V}$ ,  $pclk = 20\text{ MHz}$ ,  $mclk = 100\text{ MHz}$ , UTOPIA clock = 20 MHz, cell bus clock = 30 MHz, nominal slew rate (register 2Eh).



## 19 Timing Requirements

The following section describes the timing requirements. Capacitive loading is in the range of 10 pF to 50 pF, unless otherwise specified.

Some timing requirements are dependent on the frequency of pclk or mclk. The terms mclkp and pclkp refer to the period of their respective clocks in ns when used in the following tables.

**Table 133. Input Clocks**

Clock Name	Frequency (Max)	Voltage Level		Rise Time (Max)	Fall Time (Max)	Pulse Width (Min)	
		High	Low			High	Low
cb_wc*	66 MHz	—	—	—	—	6.06 ns	6.06 ns
cb_rc*	66 MHz	—	—	—	—	6.06 ns	6.06 ns
u_rxclk	50 MHz	2.0 V	0.8 V	4.0 ns	4.0 ns	8 ns	8 ns
u_txclk	50 MHz	2.0 V	0.8 V	4.0 ns	4.0 ns	8 ns	8 ns

Note: The cell bus write clock (cb\_wc\*) should be delayed 1.5 ns to 4 ns relative to the cell bus read clock (cb\_rc\*) to ensure sufficient data hold time.

**Table 134. Output Clocks**

Clock Name	Frequency (Max)	Rise Time (Max)	Fall Time (Max)	Pulse Width (Min)		Load
				High	Low	
sd_clk	100 MHz	1.0 ns	1.0 ns	4 ns	4 ns	15 pF
u_rxclk	50 MHz	2.0 ns	2.0 ns	8 ns	8 ns	40 pF
u_txclk	50 MHz	2.0 ns	2.0 ns	8 ns	8 ns	40 pF

**19 Timing Requirements** (continued)

**19.1 Microprocessor Interface Timing**

For access time information, see Section 6.3.2, *CelXpres T8207 Access Performance*.

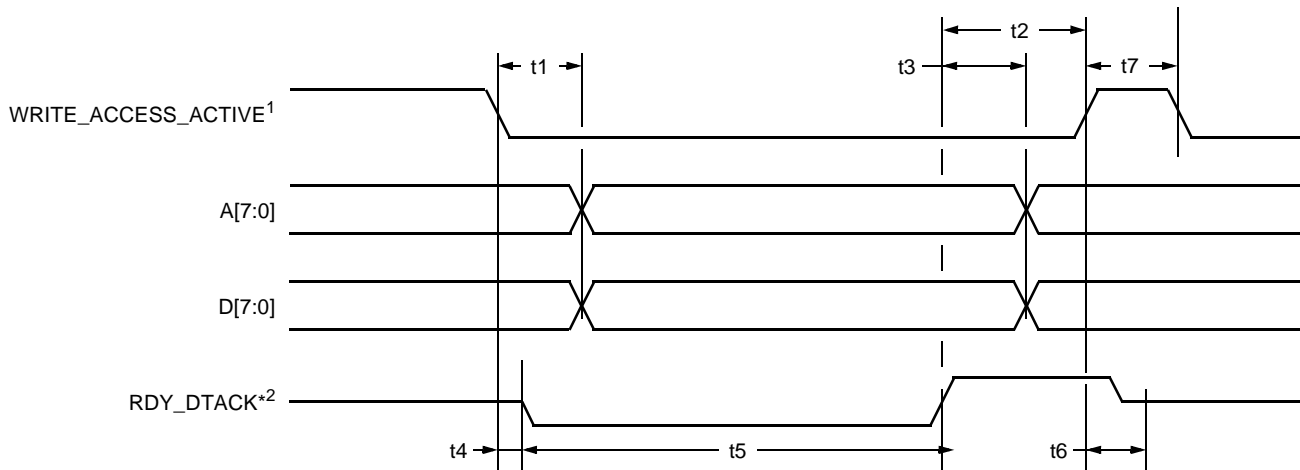

5-7787bF

1. write\_access\_active is the logical OR function of sel\* and wr\*\_ds\*.

2. Load is 15 pF.

Note: sel\* and wr\*\_ds\* must not have coinciding edges in opposite directions to prevent glitches on the write\_access\_active signal.

**Figure 21. Nonmultiplexed Intel Mode Write Access Timing**

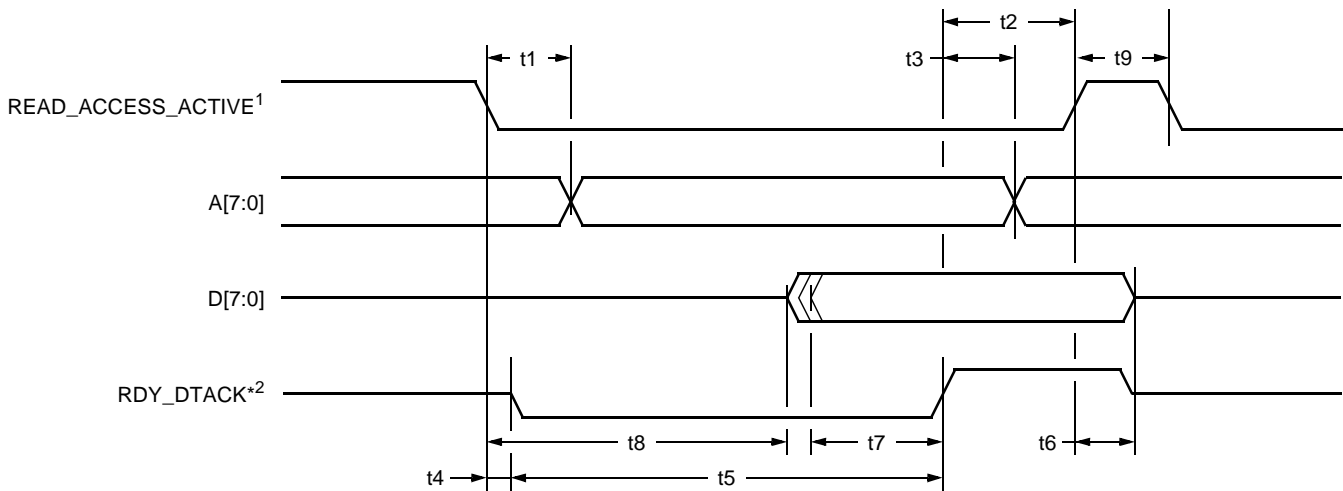

5-7788bF

1. read\_access\_active is the logical OR function of sel\* and rd\*\_wr\*.

2. Load is 15 pF.

Note: sel\* and rd\*\_wr\* must not have coinciding edges in opposite directions to prevent glitches on the read\_access\_active signals.

**Figure 22. Nonmultiplexed Intel Mode Read Access Timing**

## 19 Timing Requirements (continued)

**Table 135. Nonmultiplexed Intel Mode Write Access Timing**

Symbol	Parameter	Min	Typ	Max	Unit
t1	write_access_active Falling Edge to a[7:0] and d[7:0] Valid	—	—	2 x pclkp – 4	ns
t2	rdy_dtack* Rising Edge to write_access_active Rising Edge	0	—	—	ns
t3	rdy_dtack* Rising Edge to a[7:0] and d[7:0] Invalid	0	—	—	ns
t4	write_access_active Falling Edge to rdy_dtack* Falling Edge	0	—	12	ns
t5	rdy_dtack* Low Pulse Width <sup>1</sup>	—	—	—	—
t6	write_access_active Rising Edge to rdy_dtack* 3_state	0	—	5	ns
t7	write_access_active Rising Edge to write_access_active Falling Edge	25	—	—	ns

1. See access times in Table 10.

Note: The term pclkp in the table represents the period of pclk in ns.

**Table 136. Nonmultiplexed Intel Mode Read Access Timing**

Symbol	Parameter	Min	Typ	Max	Unit
t1	read_access_active Falling Edge to a[7:0]	—	—	2 x pclkp – 4	ns
t2	rdy_dtack* Rising Edge to read_access_active Rising Edge	0	—	—	ns
t3	rdy_dtack* Rising Edge to a[7:0] Invalid	0	—	—	ns
t4	read_access_active Falling Edge to rdy_dtack* Falling Edge	0	—	12	ns
t5	rdy_dtack* Low Pulse Width <sup>1</sup>	—	—	—	—
t6	read_access_active Rising Edge to d[7:0] Invalid	0	—	5	ns
t7	d[7:0] Valid to rdy_dtack* Rising Edge	pclkp – 4	—	—	ns
t8	read_access_active Falling Edge to d[7:0] Drive	3 x pclkp – 4	—	—	ns
t9	read_access_active Rising Edge to read_access_active Falling Edge	25	—	—	ns

1. See access times in Table 10.

Note: The term pclkp in the table represents the period of pclk in ns.

19 Timing Requirements (continued)

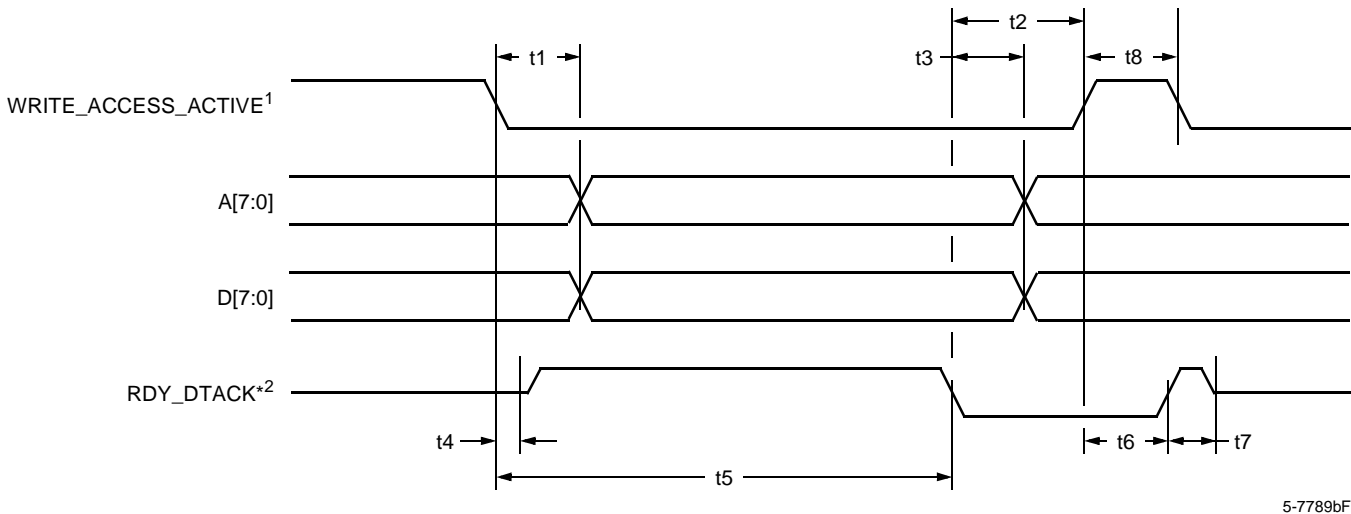

5-7789bF

1. write\_access\_active is the logical OR function of sel\*, wr\*\_ds\*, and rd\*\_wr\*.
2. Load is 50 pF.

Notes:

sel\* and wr\*\_ds\* must not have coinciding edges in opposite directions to prevent glitches on the write\_access\_active signal.

rd\*\_wr\* must be stable any time both sel\* and wr\*\_ds\* are low to prevent glitches on the write\_access\_active signals.

Figure 23. Motorola Mode Write Access Timing

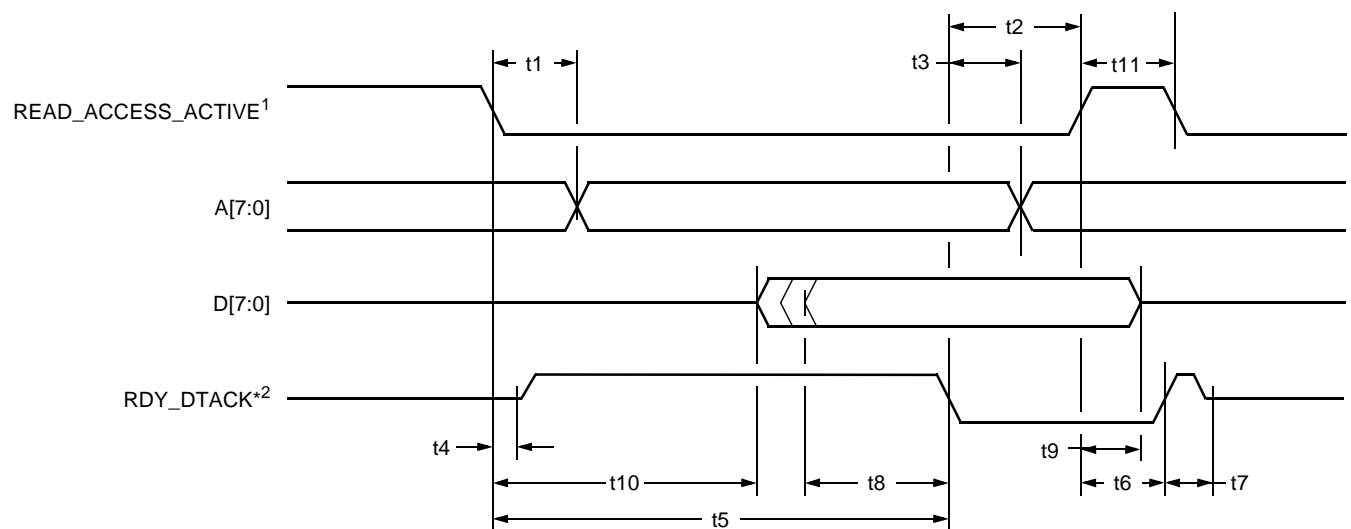

5-7790bF

1. read\_access\_active is the logical OR function of sel\*, wr\*\_ds\*, and rd\*\_wr\*.
2. Load is 50 pF.

Notes:

sel\* and wr\*\_ds\* must not have coinciding edges in opposite directions to prevent glitches on the read\_access\_active signal.

rd\*\_wr\* must be stable any time both sel\* and wr\*\_ds\* are low to prevent glitches on the read\_access\_active signals.

Figure 24. Motorola Mode Read Access Timing

## 19 Timing Requirements (continued)

**Table 137. Motorola Mode Write Access Timing**

Symbol	Parameter	Min	Typ	Max	Unit
t1	write_access_active Falling Edge to a[7:0] and d[7:0] Valid	—	—	2 x pclkp – 4	ns
t2	rdy_dtack* Falling Edge to write_access_active Rising Edge	0	—	—	ns
t3	rdy_dtack* Falling Edge to a[7:0] and d[7:0] Invalid	0	—	—	ns
t4	write_access_active Falling Edge to rdy_dtack* Drive	0	—	12	ns
t5	write_access_active Falling Edge to rdy_dtack* Falling Edge <sup>1</sup>	—	—	—	—
t6	write_access_active Rising Edge to rdy_dtack* Rising Edge	0	—	5	ns
t7	rdy_dtack* Rising Edge to rdy_dtack* 3-state	1	—	5	ns
t8	write_access_active Rising Edge to write_access_active Falling Edge	25	—	—	ns

1. See access times in Table 10.

Note: The term pclkp in the table represents the period of pclk in ns.

**Table 138. Motorola Mode Read Access Timing**

Symbol	Parameter	Min	Typ	Max	Unit
t1	read_access_active Falling Edge to a[7:0] Valid	—	—	2 x pclkp – 4	ns
t2	rdy_dtack* Falling Edge to read_access_active Rising Edge	0	—	—	ns
t3	rdy_dtack* Falling Edge to a[7:0] Invalid	0	—	—	ns
t4	read_access_active Falling Edge to rdy_dtack* Drive	0	—	12	ns
t5	read_access_active Falling Edge to rdy_dtack* Falling Edge <sup>1</sup>	—	—	—	—
t6	read_access_active Rising Edge to rdy_dtack* Rising Edge	0	—	5	ns
t7	rdy_dtack* Rising Edge to rdy_dtack* 3-state	1	—	5	ns
t8	d[7:0] Valid to rdy_dtack* Falling Edge	pclkp – 4	—	—	ns
t9	read_access_active Rising Edge to d[7:0] Invalid	0	—	5	ns
t10	read_access_active Falling Edge to d[7:0] Drive	3 x pclkp – 4	—	—	ns
t11	read_access_active Rising Edge to read_access_active Falling Edge	25	—	—	ns

1. See access times in Table 10.

Note: The term pclkp in the table represents the period of pclk in ns.

19 Timing Requirements (continued)

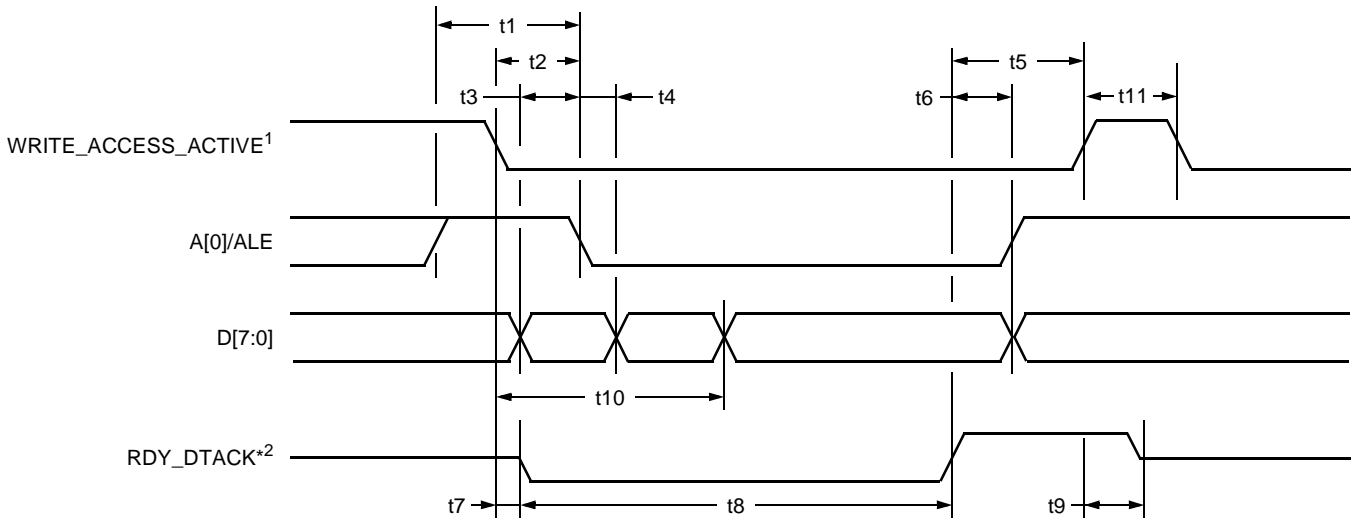

5-7791bF

1. write\_access\_active is the logical OR function of sel\* and wr\*\_ds\*.
2. Load is 50 pF.

Note: sel\* and wr\*\_ds\* must not have coinciding edges in opposite directions to prevent glitches on the write\_access\_active signal.

Figure 25. Multiplexed Intel Mode Write Access Timing

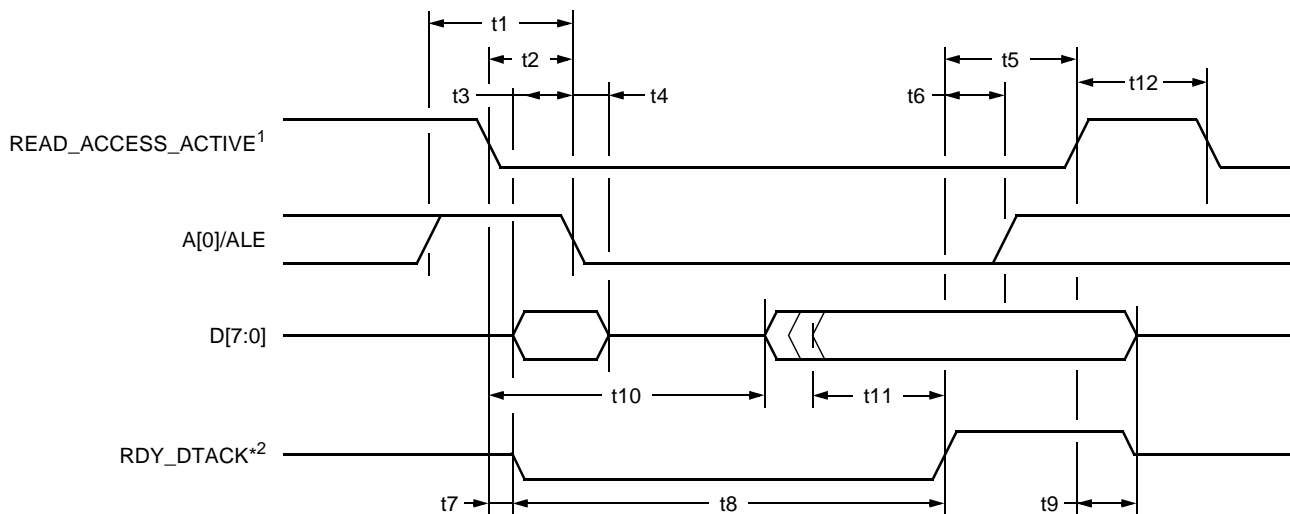

5-7792bF

1. read\_access\_active is the logical OR function of sel\* and rd\*\_wr\*.
2. Load is 50 pF.

Note: sel\* and rd\*\_wr\* must not have coinciding edges in opposite directions prevent glitches on the read\_access\_active signals.

Figure 26. Multiplexed Intel Mode Read Access Timing

## 19 Timing Requirements (continued)

**Table 139. Multiplexed *Intel* Mode Write Access Timing**

Symbol	Parameter	Min	Typ	Max	Unit
t1	a[0]/ale High Pulse Width	5	—	—	ns
t2	write_access_active Falling Edge to a[0]/ale Falling Edge	—	—	2 x pclkp – 4	ns
t3	d[7:0] Valid to a[0]/ale Falling Edge	5	—	—	ns
t4	a[0]/ale Falling Edge to d[7:0] Invalid	0	—	—	ns
t5	rdy_dtack* Rising Edge to write_access_active Rising Edge	0	—	—	ns
t6	rdy_dtack* Rising Edge to d[7:0] Invalid and a[0]/ale Rising Edge	0	—	—	ns
t7	write_access_active Falling Edge to rdy_dtack* Falling Edge	0	—	12	ns
t8	rdy_dtack* Low Pulse Width <sup>1</sup>	—	—	—	—
t9	write_access_active Rising Edge to rdy_dtack* 3-state	0	—	5	ns
t10	write_access_active Falling Edge to d[7:0] Valid	—	—	2 x pclkp – 4	ns
t11	write_access_active Rising Edge to write_access_active Falling Edge	25	—	—	ns

1. See access times in Table 10.

Note: The term pclkp in the table represents the period of pclk in ns.

**Table 140. Multiplexed *Intel* Mode Read Access Timing**

Symbol	Parameter	Min	Typ	Max	Unit
t1	a[0]/ale High Pulse Width	5	—	—	ns
t2	read_access_active Falling Edge to a[0]/ale Falling Edge	—	—	2 x pclkp – 4	ns
t3	d[7:0] Valid to a[0]/ale Falling Edge	5	—	—	ns
t4	a[0]/ale Falling Edge to d[7:0] Invalid	0	—	—	ns
t5	rdy_dtack* Rising Edge to read_access_active Rising Edge	0	—	—	ns
t6	rdy_dtack* Rising Edge to a[0]/ale Rising Edge	0	—	—	ns
t7	read_access_active Falling Edge to rdy_dtack* Falling Edge	0	—	12	ns
t8	rdy_dtack* Low Pulse Width <sup>1</sup>	—	—	—	—
t9	read_access_active Rising Edge to d[7:0] Invalid and rdy_dtack* 3-state	0	—	5	ns
t10	read_access_active Falling Edge to d[7:0] Drive	3 x pclkp – 4	—	—	ns
t11	d[7:0] Valid to rdy_dtack* Rising Edge	pclkp – 4	—	—	ns
t12	read_access_active Rising Edge to read_access_active Falling Edge	25	—	—	ns

1. See access times in Table 10.

Note: The term pclkp in the table represents the period of pclk in ns.

## 19 Timing Requirements (continued)

### 19.2 UTOPIA Timing

**Table 141. TX UTOPIA Timing (70 pF Load on Outputs)**

Parameter	Min	Typ	Max	Unit
u_txclk Frequency	0	—	50	MHz
u_txclk Duty Cycle	40	—	60	%
Output Delay from u_txclk, Applies to the Following Signals:				
u_txaddr[4:0]	2.96	—	10.32	ns
u_txdata[7:0]	2.99	—	8.73	ns
u_txsoc	2.65	—	7.67	ns
u_txprty	2.56	—	7.64	ns
u_txenb*[3:0]	2.86	—	10.72	ns
u_txclav[0],	2.53	—	7.59	ns
u_shr_o	5.09	—	13.79	ns
Input Setup Time to u_txclk, Applies to the Following Signals:				
u_shr_i, u_txclav[3:0], u_txenb*[0], u_txaddr[4:0]	4	—	—	ns
Input Hold Time from u_txclk, Applies to the Following Signals:				
u_shr_i, u_txclav[3:0], u_txenb*[0], u_txaddr[4:0]	1	—	—	ns

**Table 142. RX UTOPIA Timing (70 pF Load on Outputs)**

Parameter	Min	Typ	Max	Unit
u_rxclk Frequency	0	—	50	MHz
u_rxclk Duty Cycle	40	—	60	%
Output Delay from u_rxclk, Applies to the Following Signals:				
u_rxaddr[4:0],	3.01	—	8.83	ns
u_rxenb*[3:0],	2.83	—	7.86	ns
u_rxclav[0]	2.25	—	6.88	ns
Input Setup Time to u_rxclk, Applies to the Following Signals:				
u_rxenb*[3:0], u_rxclav[3:0], u_rxdata[7:0], u_rxparity, u_rxsoc, u_rxaddr[4:0]	4	—	—	ns
Input Hold Time from u_rxclk, Applies to the Following Signals:				
u_rxenb*[3:0], u_rxclav[3:0], u_rxdata[7:0], u_rxprty, u_rxsoc, u_rxaddr[4:0]	1	—	—	ns



## 19 Timing Requirements (continued)

### 19.3 External LUT Memory Timing

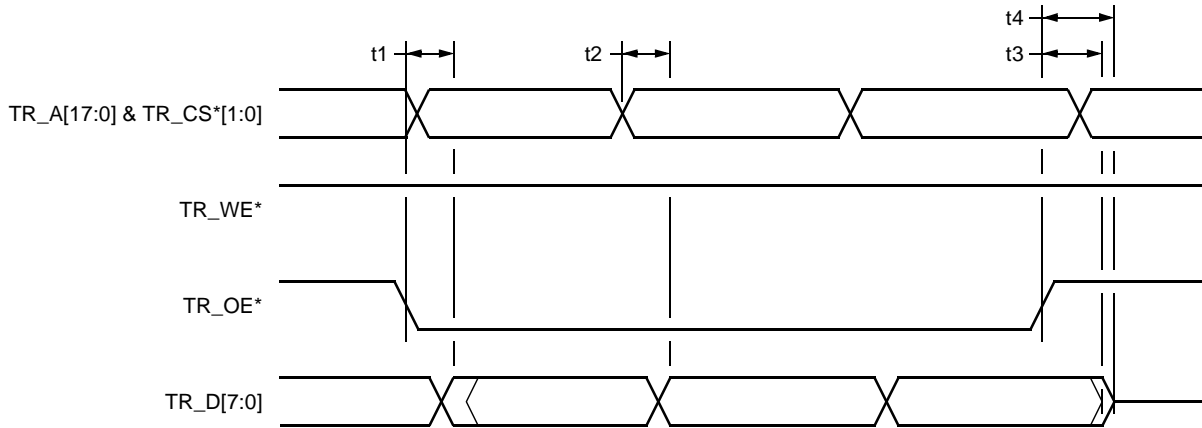

Note: 30 pF load on outputs.

5-7795bF

**Figure 27. External LUT Memory Read Timing (cyc\_per\_acc = 2 and cyc\_per\_acc = 3)**

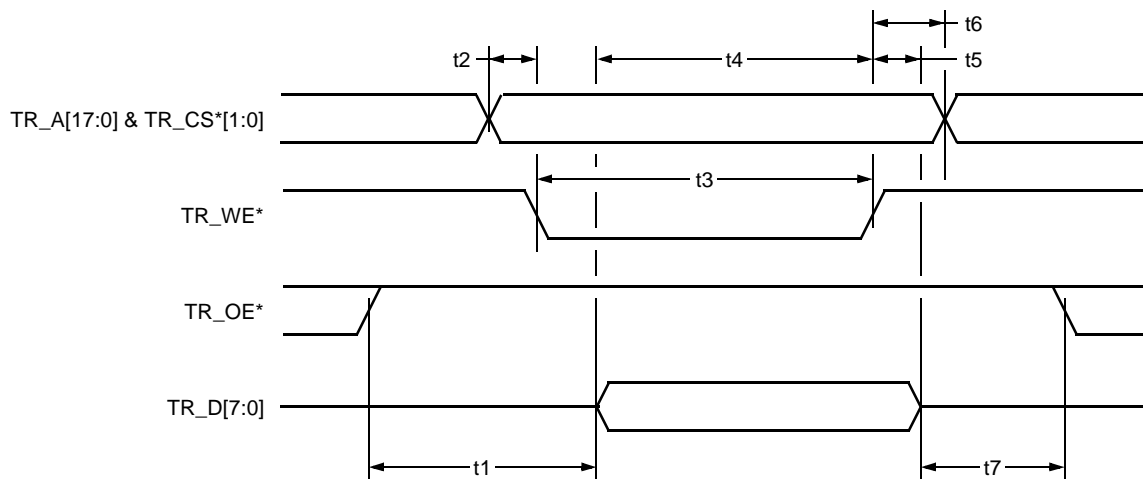

Note: 30 pF load on outputs.

5-7796aF

**Figure 28. External LUT Memory Write Timing (cyc\_per\_acc = 2 and cyc\_per\_acc = 3)**

## 19 Timing Requirements (continued)

The term mclkp in Tables 143, 144, 145, and 146, represents the period of mclk in ns.

**Table 143. External LUT Memory Read Timing (cyc\_per\_acc = 2)**

Symbol	Parameter	Min	Typ	Max	Unit
t1	tr_oe* Low to tr_d[7:0] Driven by SRAM Chip	0	—	2 x mclkp – 11	ns
t2	tr_a[17:0] & tr_cs*[1:0] Valid to tr_d[7:0] Valid	0	—	2 x mclkp – 11	ns
t3	tr_oe* High to tr_d[7:0] Invalid	0	—	—	ns
t4	tr_oe* High to tr_d[7:0] 3-State	—	—	mclkp	ns

**Table 144. External LUT Memory Read Timing (cyc\_per\_acc = 3)**

Symbol	Parameter	Min	Typ	Max	Unit
t1	tr_oe* Low to tr_d[7:0] Driven by SRAM Chip	0	—	3 x mclkp – 11	ns
t2	tr_a[17:0] & tr_cs*[1:0] Valid to tr_d[7:0] Valid	0	—	3 x mclkp – 11	ns
t3	tr_oe* High to tr_d[7:0] Invalid	0	—	—	ns
t4	tr_oe* High to tr_d[7:0] 3-State	—	—	mclkp	ns

**Table 145. External LUT Memory Write Timing (cyc\_per\_acc = 2)**

Symbol	Parameter	Min	Typ	Max	Unit
t1	tr_oe* High to tr_d[7:0] Driven	mclkp – 4	—	—	ns
t2	tr_a[17:0] Setup to tr_we* Falling Edge	2	—	—	ns
t3	tr_we* Low Pulse Width	mclkp – 1	—	—	ns
t4	tr_d[7:0] Setup to tr_we* Rising Edge	mclkp	—	—	ns
t5	tr_d[7:0] Hold from tr_we* Rising Edge	2	—	—	ns
t6	tr_a[17:0] Hold from tr_we* Rising Edge	2	—	—	ns
t7	tr_d[7:0] 3-State to tr_oe* Low	0	—	—	ns

**Table 146. External LUT Memory Write Timing (cyc\_per\_acc = 3)**

Symbol	Parameter	Min	Typ	Max	Unit
t1	tr_oe* High to tr_d[7:0] Driven	mclkp – 4	—	—	ns
t2	tr_a[17:0] Setup to tr_we* Falling Edge	2	—	—	ns
t3	tr_we* Low Pulse Width	2 x mclkp – 1	—	—	ns
t4	tr_d[7:0] Setup to tr_we* Rising Edge	2 x mclkp	—	—	ns
t5	tr_d[7:0] Hold from tr_we* Rising Edge	2	—	—	ns
t6	tr_a[17:0] Hold from tr_we* Rising Edge	2	—	—	ns
t7	tr_d[7:0] 3-State to tr_oe* Low	0	—	—	ns

## 19 Timing Requirements (continued)

### 19.4 Cell Bus Timing

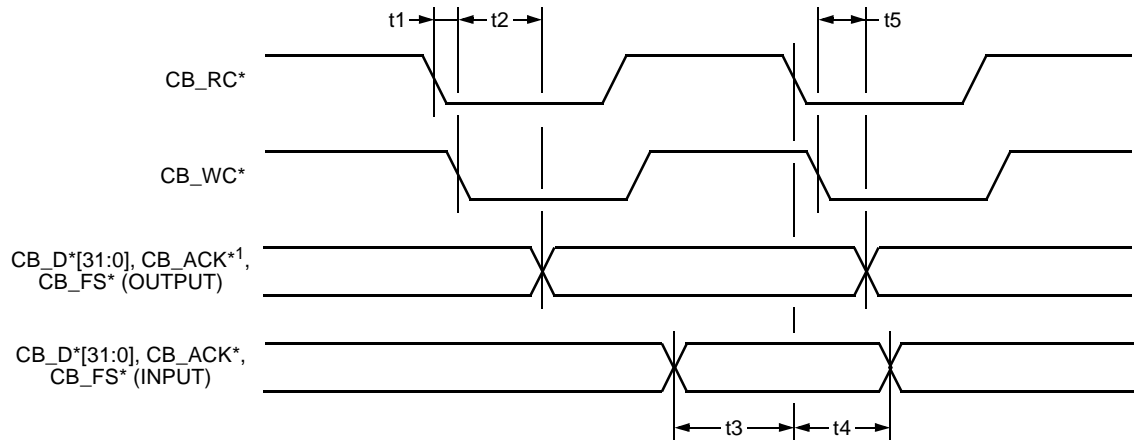

1. 25 pF load.

5-7797bF

Figure 29. Cell Bus Timing

Table 147. Cell Bus Timing

Symbol	Parameter	Min	Typ	Max	Unit
t1	cb_rc* Falling Edge to cb_wc* Falling Edge	1.5	—	4	ns
t2	cb_wc* Falling Edge to Output Valid <sup>1</sup>	—	—	11.5	ns
t3	Input Setup to cb_rc* Falling Edge	1	—	—	ns
t4	Input Hold from cb_rc* Falling Edge	2	—	—	ns
t5	cb_wc* Falling Edge to Output Invalid <sup>1</sup>	3	—	—	ns

1. Pin loading = 25 pF.

## 19 Timing Requirements (continued)

### 19.5 SDRAM Interface Timing

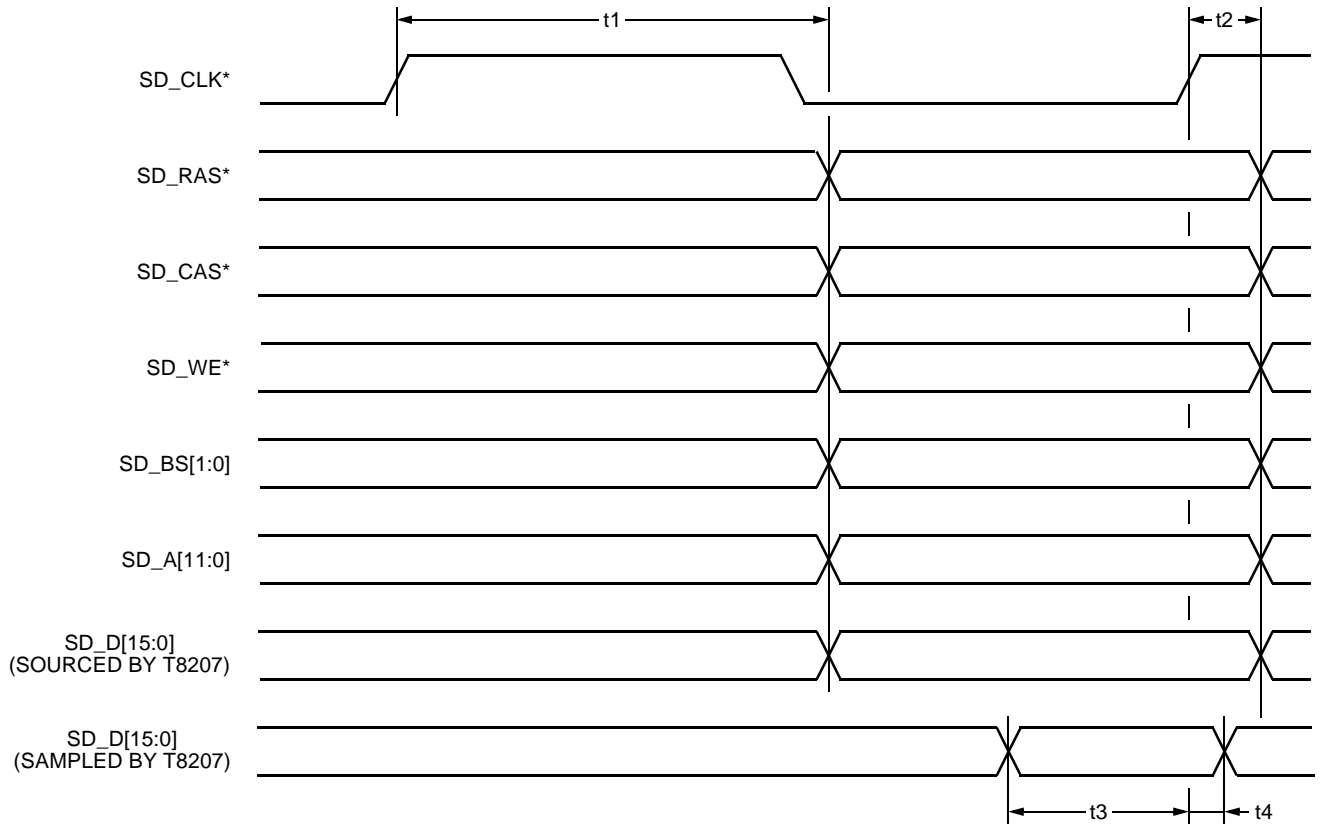

Note: 15 pF load on outputs.

5-7798BF

Figure 30. SDRAM Interface Timing

Table 148. SDRAM Interface Timing

Symbol	Parameter	Min	Typ	Max	Unit
t1	sd_clk Rising to Outputs Valid	—	—	7	ns
t2	sd_clk Rising to Outputs Invalid	1.5	—	—	ns
t3	sd_d[15:0] Input Setup to sd_clk Rising Edge	3	—	—	ns
t4	sd_d[15:0] Input Hold from sd_clk Rising Edge	0	—	—	ns

## 20 Outline Diagram

All dimensions shown are in millimeters.

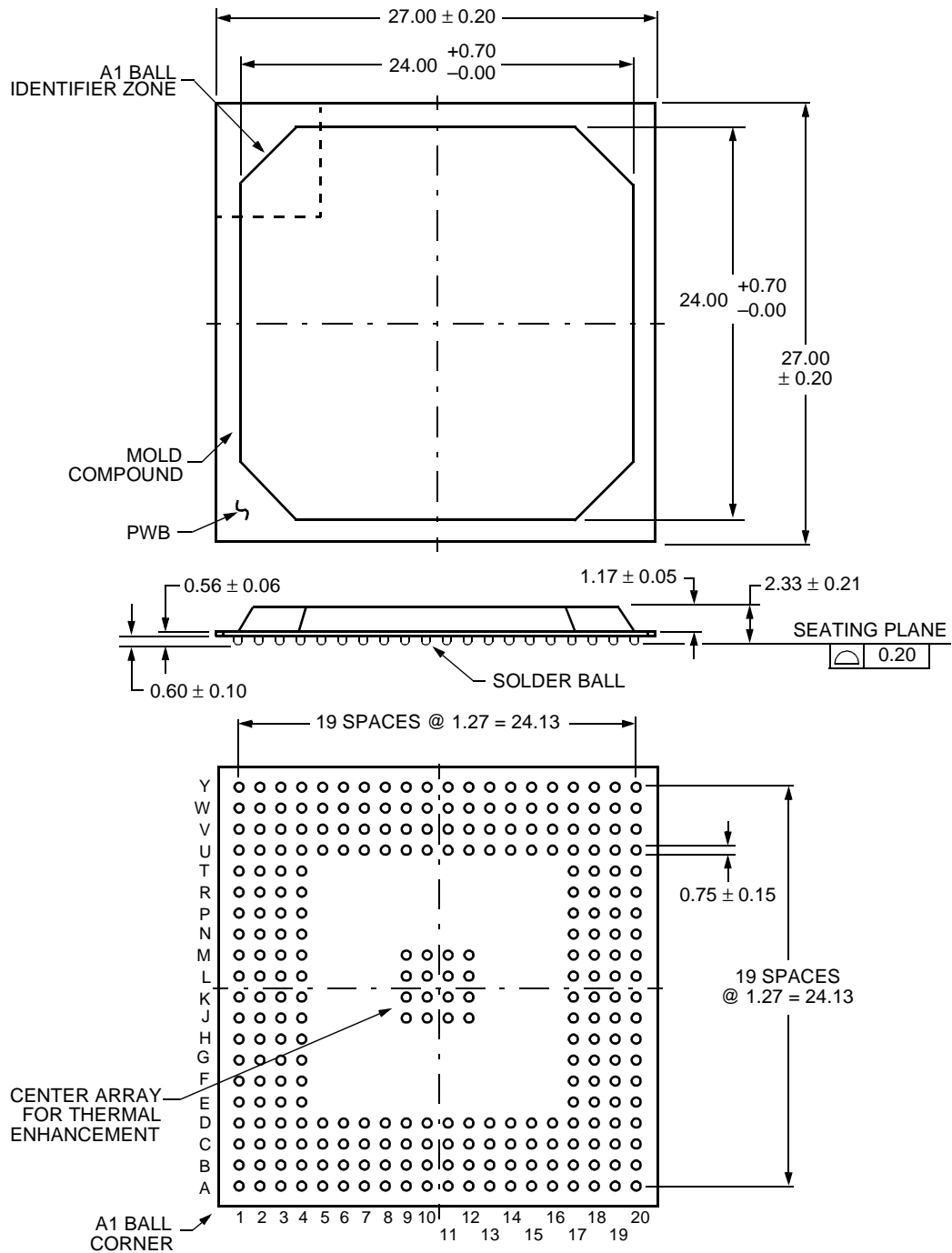

## 21 Ordering Information

Part Number	Package	Comcode
T-8207---BAL-DB	272-pin PBGAM, Dry Pack Tray	108698077
T-8207---BAL-DT	272-pin PBGAM Dry-bagged, Tape & Reel	108699265

*Motorola* is a registered trademark of Motorola, Inc.  
*Intel* is a registered trademark of Intel Corporation.  
*Transwitch* and *CellBus* are registered trademarks of Transwitch Corp.

---

For additional information, contact your Agere Systems Account Manager or the following:

INTERNET: <http://www.agere.com>  
E-MAIL: [docmaster@agere.com](mailto:docmaster@agere.com)  
N. AMERICA: Agere Systems Inc., 555 Union Boulevard, Room 30L-15P-BA, Allentown, PA 18109-3286  
**1-800-372-2447**, FAX 610-712-4106 (In CANADA: **1-800-553-2448**, FAX 610-712-4106)  
ASIA: Agere Systems Hong Kong Ltd., Suites 3201 & 3210-12, 32/F, Tower 2, The Gateway, Harbour City, Kowloon  
**Tel. (852) 3129-2000**, FAX (852) 3129-2020  
CHINA: **(86) 21-5047-1212** (Shanghai), **(86) 10-6522-5566** (Beijing), **(86) 755-695-7224** (Shenzhen)  
JAPAN: **(81) 3-5421-1600** (Tokyo), KOREA: **(82) 2-767-1850** (Seoul), SINGAPORE: **(65) 778-8833**, TAIWAN: **(886) 2-2725-5858** (Taipei)  
EUROPE: **Tel. (44) 7000 624624**, FAX (44) 1344 488 045

---

Agere Systems Inc. reserves the right to make changes to the product(s) or information contained herein without notice. No liability is assumed as a result of their use or application.  
*CelXpres* is a trademark of Agere Systems Inc.