

Lucent Technologies
Bell Labs Innovations



T9000 ISDN Network Termination Node (NTN) Device

1 Description

The T9000 is an ISDN network termination node device that is highly integrated and provides a low-cost solution to support the following:

- All standard NT1 functions required to attach an S/T interface device to an ISDN network. In addition, the T9000 also supports attachment of two standard analog (POTS) telephones for communications over an ISDN network.
- Intelligent network termination (INT/Smart NT1) functions, with its built-in controller and support for attachment of two analog phones for communications over an ISDN network.
- A variation of the V5.1 signaling protocol called narrowband multiservice delivery system (NMDS) adopted by countries using the V5 signaling protocol (e.g., United Kingdom)

In addition, the T9000 can also be used for pair-gain applications where support for more than one telephone line is required without the installation of an additional pair of wires from the telephone central office to the customer premises.

2 Features

- Complete interface to basic rate ISDN networks at the S/T-interface and U-interface reference points.
- U-interface (LT or NT operation) conforms to ANSI* T1.601 and ETSI TS 080 standards.
- S/T-interface conforms to ANSI T1.605 standard, ITU-T I.430 recommendation, and ETSI ETS 300 012 standard for the network termination (NT) side of the network.
- Low power consumption.
- D-channel HDLC formatter with address recognition and integrated contention resolution scheme.
- 64-byte D-channel FIFOs.
- GCI+ interface supporting GCI and generic TDM modes for interfacing to a wide variety of POTS circuits.

- General-purpose I/O (GPIO) ports with interrupt capability for interfacing to SLICs, codecs, DTMF decoders, and other peripheral devices.
- Three low-power, general-purpose comparators.
- Two 100 kHz programmable PWM outputs with an automatic sine wave generation mode to support ringing, pulse metering, etc.
- 20 kHz—200 kHz programmable dc/dc converter synchronization output.
- JTAG boundary scan on all digital pins.
- Power-saving mode.
 - In this mode, the unused interfaces of the T9000, such as, microcontroller, PWMs, and comparator can remain in powerdown mode, thus resulting in significant reduction in power consumption (see Section 20.2, Power Consumption).
- Packaged in a 100-pin TQFP (thin quad flat pkg).
- 5 V power supply.
- Operating temperature range: -40 °C to +85 °C.
- Integrated 80C32 microcontroller with the following features:
 - Programmable clock rates (MHz): 15.36, 7.68, 3.84, 1.92, 0.96.
 - 4K internal SRAM.
 - 64K internal ROM.
 - Supports external ROM/RAM.
 - Can be disabled via pin strap (sleep mode) for use with an external emulator.
 - Programmable watchdog timer.

External ROM and RAM (64K x 8 maximum each) are accessed through an external data/address bus.

Support for ROM and RAM space above the 64K limit can be accomplished by memory paging using one or more GPIO signals as an external chip select. Power management routines may be implemented through the microcontroller to power down most of the internal submodules, including the microcontroller itself. An autosleep mode is also included, allowing the microcontroller to stop its internal clock and be automatically restarted (microcontroller wake-up) whenever any interrupt is triggered.

* ANSI is a registered trademark of American National Standards Institute, Inc.



Table of Contents

Contents	Page	Contents	Page
1 Description.....	1	10 GCI+ Interface Module	69
2 Features	1	10.1 TDM Mode (GCCF, GMODE[1:0] = 1x)	69
3 Block Diagram	6	10.2 GCI Modes (GCCF[GMODE(1:0)] = 0x)	73
4 Pin Information	7	10.3 GCI-NT Mode (GCCF[GMODE(1:0)] = 00)	73
5 Control Register Memory Space	15	10.3.1 GCI-SCIT Mode (GCCF, GMODE[1:0] = 01)	75
6 Functional Modules	17	10.3.2 Monitor Message Transfer	77
6.1 80C32 Microcontroller Module (80C32 Block) ..	17	10.4 C/I Message Transfer.....	77
6.2 Program Address Space.....	17	10.5 GCI+ Powerdown Mode.....	77
6.3 Data Address Space.....	17	10.6 GCI+ Loopbacks	78
6.4 Timers	17	10.7 GCI+ Register Set.....	79
6.5 Interrupts.....	17	11 GPIO Ports	85
6.6 Interrupt Register Set.....	18	11.1 GPIO Register Set	86
6.7 Clock Generator.....	21	12 PWM Module	93
6.8 Watchdog Timer.....	22	12.1 PWM Manual/Timer Operation Mode.....	94
6.9 On-Circuit Emulation (ONCE) Mode	23	12.2 PWM Auto Operation (Sine) Mode.....	94
6.10 Emulation	23	12.3 PWSM ROM.....	96
6.11 Module I/O	23	12.4 PWM Auto Mode Example.....	97
6.12 Special Instructions for Using the Lucent 80C32 Block.....	24	12.5 PWM Powerdown Mode.....	100
6.12.1 Port Configuration	24	12.6 PWM Module Register Set.....	100
6.12.1.1 Ports 0 and 2	24	13 dc/dc Control Generator	104
6.12.1.2 Port 1	24	13.1 dc/dc Control Generator Register Set.....	104
6.12.1.3 Port 3	24	14 Comparators.....	105
6.13 Serial Port Timing	25	14.1 Comparators Register Set.....	106
6.14 External Program Memory Characteristics	26	14.2 Configuration Sequence	107
7 Transmission Superblock	29	15 Test Mode.....	108
7.1 U-Interface Block (U Block).....	29	16 Loopbacks	109
7.2 S/T-Interface Block (S Block).....	29	17 Absolute Maximum Ratings.....	110
7.3 Data Flow/Activation Control Module (DFAC)....	30	18 Handling Precautions	110
7.3.1 EOC State Machine (EOCSM).....	30	19 Recommended Operating Conditions	110
7.3.2 Automatic EOC (AUTOEOC) Mode	30	20 Electrical Characteristics	111
7.3.3 Manual EOC Mode.....	30	20.1 Power Supply	111
7.3.4 Data Flow Control.....	32	20.2 Power Consumption.....	111
7.4 Microcontroller Access to Upstream and Downstream B1 and B2 Channels.....	32	20.3 S/T-Interface Receiver Common-Mode Rejection	111
7.5 LT Mode.....	32	20.4 Pin Electrical Characteristics.....	112
7.6 DFAC Register Set	33	21 Crystal Characteristics.....	113
8 Device Operation Control	47	22 Timing Characteristics	113
8.1 Device Operation Register.....	47	23 Application Diagrams.....	114
9 HDLC with FIFO Module	52	24 Outline Diagram.....	116
9.1 HDLC Transmitter	52	24.1 100-Pin TQFP	116
9.1.1 HDLC Transmitter Initialization.....	52	25 Ordering Information.....	117
9.2 HDLC Transmitter D-Channel Access	53	26 Register Set Summary	118
9.3 HDLC Receiver	54		
9.3.1 HDLC Receiver Initialization.....	54		
9.3.1.1 Overrun Condition.....	56		
9.4 Address Recognition.....	56		
9.5 HDLC Register Set	58		

Table of Contents (continued)

Tables	Page	Tables	Page
Table 1. S/T-Interface Pins (6)	8	Table 34. SSR: S-Interface Status Register (0x11)	42
Table 2. U-Interface Pins (7)	8	Table 35. MFR0: Multiframe Register, Q-Channel Data (0x12)	43
Table 3. GCI+ Pins (5)	9	Table 36. MFR1: Multiframe Register, S-Sub- channel Data (0x13)	43
Table 4. GPIO Pins (24)	10	Table 37. UIR: U-Interface Interrupt Register (0x14)	44
Table 5. 80C32 External Access Pins (27)	11	Table 38. UIE: U-Interface Interrupt Enable (0x15)	45
Table 6. Comparators (6)	13	Table 39. SIR: S-Interface Interrupt Register (0x16)	46
Table 7. JTAG Pins (4)	13	Table 40. SIE: S-Interface Interrupt Enable Register (0x17)	46
Table 8. Miscellaneous Pins (2)	14	Table 41. DOCR: Device Operation Control Register (0x50)	47
Table 9. Oscillator Pins (2)	14	Table 42. B1UP: B1-Channel Upstream Data from GCI to U-interface (0x51).....	47
Table 10. Power and Ground Pins	14	Table 43. B2UP: B2-Channel Upstream Data from GCI to U-interface (0x52).....	48
Table 11. Control Register Memory Space	15	Table 44. B1DN: B1-Channel Downstream Data from U-Interface to GCI (0x53)	48
Table 12. GIR0: Global Interrupt Register 0 (0x00)	18	Table 45. B2DN: B2-Channel Downstream Data from U-Interface to GCI (0x54)	48
Table 13. GIR1: Global Interrupt Register 1 (0x01)	19	Table 46. Reserved 1: Reserved Register for Internal Use (0x55)	49
Table 14. GIE: Global Interrupt Enable Register (0x02)	20	Table 47. Reserved 2: Reserved Register for Internal Use (0x56)	49
Table 15. UPCR: Microcontroller Clock Control Register (0x03)	21	Table 48. Reserved 3: Reserved Register for Internal Use (0x57)	49
Table 16. WDT: Microcontroller Watchdog Timer Control (0x04)	22	Table 49. Reserved 4: Reserved Register for Internal Use (0x58)	50
Table 17. Port Direction Registers	24	Table 50. Reserved 5: Reserved Register for Internal Use (0x59)	50
Table 18. Standard 80C32 RCLK/TCLK Options	25	Table 51. Reserved 6: Reserved Register for Internal Use (0x5A)	50
Table 19. Lucent 80C32 RCLK/TCLK Options	25	Table 52. Reserved 7: Reserved Register for Internal Use (0x5B)	50
Table 20. External Program Memory Characteristics	26	Table 53. Reserved 8: Reserved Register for Internal Use (0x5C)	51
Table 21. AUTOEOC = 1 Messages (Data/Messages = 1) That Initiate Actions	31	Table 54. Reserved 9: Reserved Register for Internal Use (0x5D)	51
Table 22. DFAC: DFAC Configuration Register (0x05)	33	Table 55. HTCF: HDLC Transmitter Configuration Register (0x18)	58
Table 23. DFR: Data Flow Register (0x06)	34	Table 56. HRCF: HDLC Receiver Configuration Register (0x19)	59
Table 24. UCR0: U-Interface Control Register #0 (0x07)	35	Table 57. HTHH: HDLC Transmit FIFO Threshold (0x1A)	60
Table 25. UCR1: U-Interface Control Register #1 (0x08)	36	Table 58. HRTH: HDLC Receive FIFO Threshold (0x1B)	60
Table 26. USR0: U-Interface Status Register #0 (0x09)	37	Table 59. HTSA: HDLC Transmit FIFO Space Available (0x1C)	61
Table 27. USR1: U-Interface Status Register #1 (0x0A)	37		
Table 28. ECR0: EOC Control Register 0—Command and Address (0x0B)	38		
Table 29. ECR1: EOC Control Register 1—Message (0x0C)	39		
Table 30. ESR0: EOC Status Register 0—Command and Address (0x0D)	39		
Table 31. ESR1: EOC Status Register 1—Message (0x0E)	39		
Table 32. SCR0: S-Interface Control Register #0 (0x0F)	40		
Table 33. SCR1: S-Interface Control Register #1 (0x10)	41		

Table of Contents (continued)

Tables	Page	Tables	Page
Table 60. HRDA: HDLC Receive FIFO Data Available (0x1D)	61	Table 91. GPD1R1: GPIO Port 1 Pin Direction (0x39)	87
Table 61. HTX: HDLC Transmit Data (0x1E)	61	Table 92. GPD1R2: GPIO Port 2 Pin Direction (0x3A)	87
Table 62. HTXL: HDLC Transmit Data Last Byte (0x1F)	62	Table 93. GPAF0: GPIO Alternate Function Register #0 (0x3B)	88
Table 63. HRX: HDLC Receive Data (0x20)	62	Table 94. GPAF1: GPIO Alternate Function Register #1 (0x3C)	89
Table 64. HSCR: HDLC SAPI C/R Bit Mask (0x21)	62	Table 95. GPD0: GPIO Port 0 Data Register (0x3D)	89
Table 65. HSM0: HDLC SAPI Match Pattern 0 (0x22)	63	Table 96. GPD1: GPIO Port 1 Data Register (0x3E)	90
Table 66. HTM0: HDLC TEI Match Pattern 0 (0x23)	63	Table 97. GPD2: GPIO Port 2 Data Register (0x3F)	90
Table 67. HSM1: HDLC SAPI Match Pattern 1 (0x24)	63	Table 98. GPLEI: GPIO Level-Edge-Triggered Interrupt Control (0x40)	90
Table 68. HTM1: HDLC TEI Match Pattern 1 (0x25)	64	Table 99. GPPOL: GPIO Interrupt Polarity Control (0x41)	91
Table 69. HSM2: HDLC SAPI Match Pattern 2 (0x26)	64	Table 100. GPIR: GPIO Interrupt Register (0x42)	91
Table 70. HTM2: HDLC TEI Match Pattern 2 (0x27)	64	Table 101. GPIE: GPIO Interrupt Enable (0x43)	92
Table 71. HSM3: HDLC SAPI Match Pattern 3 (0x28)	64	Table 102. ROM Code	96
Table 72. HTM3: HDLC TEI Match Pattern 3 (0x29)	65	Table 103. PWM Sine Modulator Programming Example	98
Table 73. HSMOD: HDLC SAPI Modifier Register (0x2A)	65	Table 104. PW0CF: Pulse-Width Modulator 0 Configuration (0x44)	100
Table 74. HTMOD: HDLC TEI Modifier Register (0x2B)	66	Table 105. PW0VH: Pulse-Width Modulator 0 Pulse-Width Value, High Byte (0x45)	101
Table 75. HIR: HDLC Interrupt Register (0x2C)	67	Table 106. PW0VL: Pulse-Width Modulator 0 Pulse-Width Value, Low Byte (0x46)	101
Table 76. HIE: HDLC Interrupt Enable 15 (0x2D)	68	Table 107. PW1CF: Pulse-Width Modulator 1 Configuration (0x47)	102
Table 77. GCI+ Interface Signals	69	Table 108. PW1VH: Pulse-Width Modulator 1 Pulse-Width Value, High Byte (0x48)	103
Table 78. TDM Data Rate and Clock Options	70	Table 109. PW1VL: Pulse-Width Modulator 1 Pulse-Width Value, Low Byte (0x49)	103
Table 79. GCI-TE Data-Slot Association	76	Table 110. PWIR: Pulse-Width Modulator Interrupt Register (0x4A)	103
Table 80. GCCF: GCI+ Configuration Register (0x2E)	79	Table 111. DCCF: dc/dc Configuration Register (0x4B)	104
Table 81. GCOF1: GCI PFS1 Offset Select (0x2F)	80	Table 112. Comparator Characteristics	106
Table 82. GCOF2: GCI PFS2 Offset Select (0x30)	80	Table 113. CME: Comparator Enable (0x4C)	106
Table 83. GCDMD: GCI Downstream (Transmit) Monitor Data (0x31)	81	Table 114. CMT: Comparator Transition Polarity (0x4D)	106
Table 84. GCDML: GCI Downstream (Transmit) Monitor Data Last (0x32)	81	Table 115. CMIR: Comparator Interrupt Register (0x4E)	107
Table 85. GCUMD: GCI Upstream (Receive) Monitor Data (0x33)	81	Table 116. CMIE: Comparator Interrupt Enable (0x4F)	107
Table 86. GCDCl: GCI Downstream (Transmit) C/I Data (0x34)	82		
Table 87. GCUCI: GCI Upstream (Receive) C/I Data (0x35)	82		
Table 88. GCIR: GCI Interrupt Register (0x36)	83		
Table 89. GCIE: GCI Interrupt Enable (0x37)	84		
Table 90. GPD1R0: GPIO Port 0 Pin Direction (0x38)	86		

Table of Contents (continued)

Tables	Page	Figures	Page
Table 117. Absolute Maximum Ratings	110	Figure 1. NTN Block Diagram.....	6
Table 118. ESD Threshold Voltage	110	Figure 2. T9000 Pinout.....	7
Table 119. Recommended Operating Conditions	110	Figure 3. NTN Data Memory Address Space	18
Table 120. Power Consumption	111	Figure 4. External Program Memory Read Cycle.....	27
Table 121. S/T-Interface Receiver Common-Mode Rejection	111	Figure 5. External Data Memory Read Cycle	27
Table 123. Digital dc Characteristics (Over Operating Ranges).....	112	Figure 6. External Data Memory Write Cycle	28
Table 123. Fundamental Mode Crystal Characteristics	113	Figure 7. Downstream EOC Analysis (AUTOEOC = 1) and Upstream EOC Processing.....	31
Table 124. Internal PLL Characteristics	113	Figure 8. 2B+D Data Flow Block Diagram.....	32
Table 126. MTC (Master Timing Clock) Requirements and Characteristics (LT Mode)	113	Figure 9. HDLC Transmitter FIFO	53
Table 126. Register Set Summary Global Registers	118	Figure 10. HDLC Receiver Status Word.....	54
Table 127. Register Set Summary DFAC Registers	118	Figure 11. HDLC Receiver FIFO Snapshot Sequence.....	55
Table 128. Register Set Summary U-Interface Control Registers	118	Figure 12. DLCI Extension and Function of SAPI0M-TEI0M Bits	57
Table 129. Register Set Summary EOC Control Registers	119	Figure 13. GCI+ Interface, TDM Mode Timing, Double Clock Mode: GCCF[CKMODE] = 0, GCCF[GMODE(1:0)] = 1x.....	71
Table 130. Register Set Summary S-Interface Registers	119	Figure 14. GCI+ Interface, TDM Mode Timing, Single Clock Mode: GCCF[CKMODE] = 1, GCCF[GMODE(1)] = 1.....	72
Table 131. Register Set Summary Multiframe Registers	119	Figure 15. NTN/T8503 Glueless TDM Interconnection	72
Table 132. Register Set Summary U-Interface Interrupt Registers	119	Figure 16. GCI-NT Frame Structure	74
Table 133. Register Set Summary S-Interface Interrupt Registers	120	Figure 17. GCI-NT Timing Diagram.....	74
Table 134. Register Set Summary HDLC Registers	121	Figure 18. GCI-TE Mode Frame Structure	76
Table 135. Register Set Summary GCI+ Registers	123	Figure 19. GCI Loopback Logic.....	78
Table 136. Register Set Summary GPIO Registers	124	Figure 20. GPIO Pin Capabilities Summary	86
Table 137. Register Set Summary PWM Registers	125	Figure 21. Pulse-Width Modulated Output Signal	93
Table 138. Register Set Summary dc/dc Register	125	Figure 22. PWMCNTRL Architecture	95
Table 139. Register Set Summary Comparator Registers	126	Figure 23. Widths of PWM Pulses Generated with a 2.5%—97.5% Modulation Width	99
		Figure 24. (A) CMV When CME Is a Periodic Pulse and (B) CMV When CMV Is Static	105
		Figure 25. Location of the Loopback Configurations.....	109
		Figure 26. NT1 Application	114
		Figure 27. NT1+ Application	114
		Figure 28. Pair Gain Application.....	115

3 Block Diagram

Figure 1 shows the architecture of the NTN device.

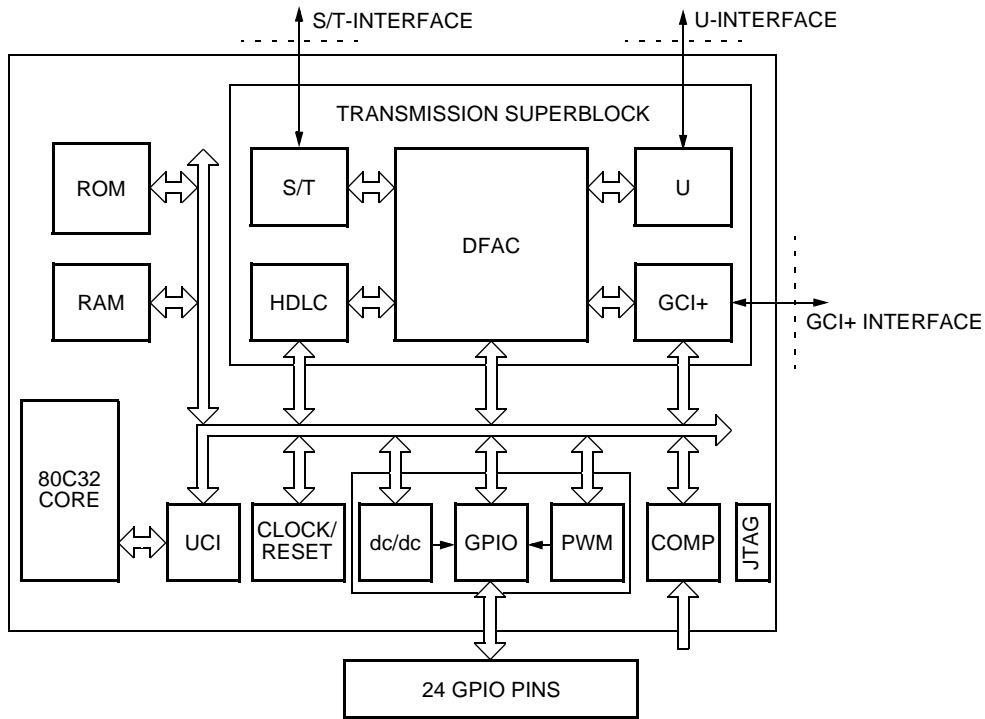

5-6494aF

LEGEND:

- dc/dc: Square wave signal generator with programmable period
- COMP: Comparator
- DFAC: Data flow/activation control
- GCI+: General control interface
- GPIO: General-purpose input/output
- HDLC: High-level datalink controller
- JTAG: Boundary-scan interface
- PWM: Pulse-width modulator
- UCI: Microcontroller interface

Figure 1. NTN Block Diagram

4 Pin Information

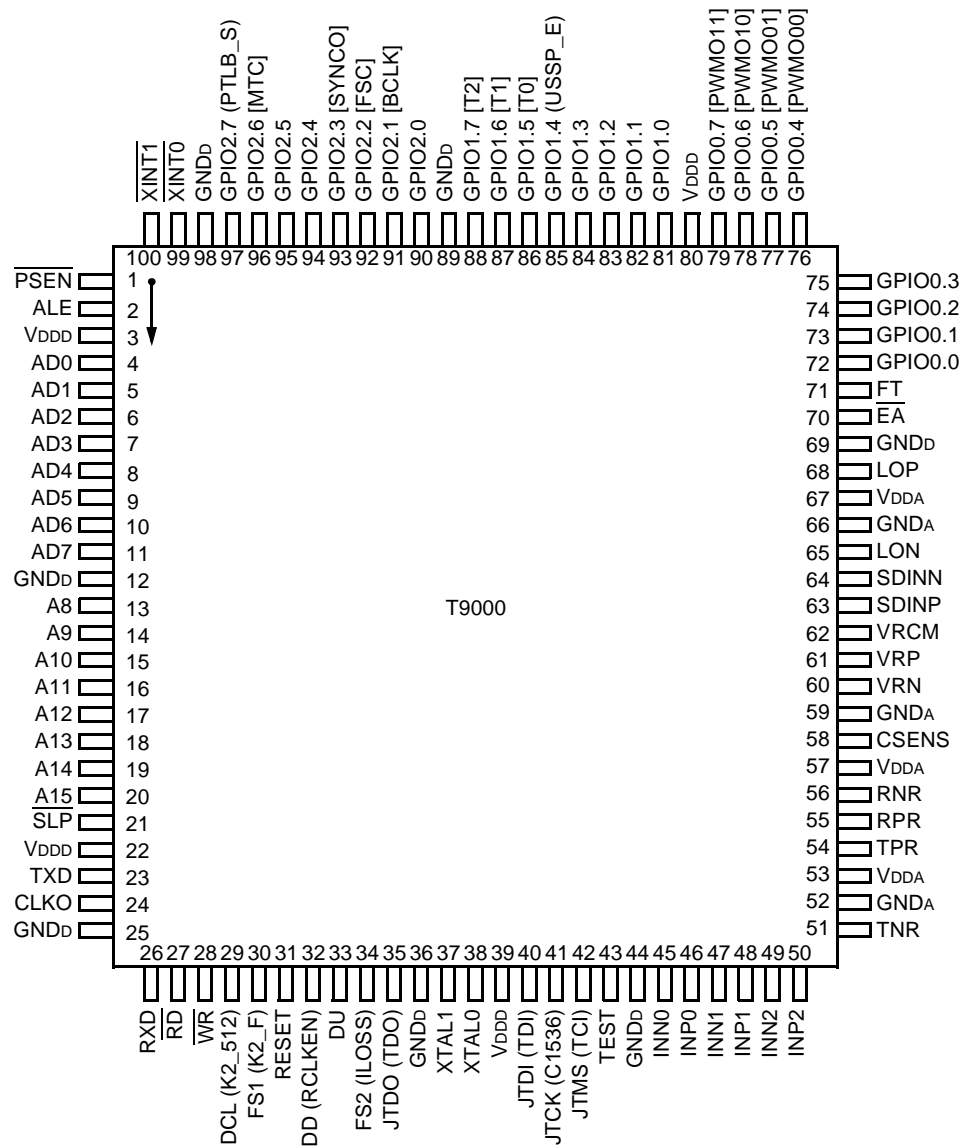

Note: Alternate pin functions, shown in parentheses (), are selected when the TEST pin is asserted.
Alternate pin functions, shown in brackets [], are selected when the corresponding register bits are set.

Figure 2. T9000 Pinout

4 Pin Information (continued)

Table 1. S/T-Interface Pins (6)

Pin Name	Pin #	Type	Pin Description
CSENS	58	—	Current Sense. Connect an 11.5 k Ω , 1%, resistor from this pin to GND _A .
FT	71	I	Fixed Timing Control. Upon exiting from RESET, the state of this pin is sampled internally and written to register SCR0[FT] to control whether the S-block receiver uses fixed or adaptive timing (note that the 80C32 is free to overwrite register bit SCR0[FT] subsequent to this). Internal 50 k Ω pull-down. 0: Adaptive Timing. Incoming data at S/T-interface is sampled at a point defined by an adaptive timing algorithm. 1: Fixed Timing. Incoming data at the S/T-interface is sampled with a fixed delay relative to the S/T transmitter clock.
TPR	54	O	Transmit Positive Rail for S/T-Interface. Positive output of S/T-interface analog transmitter. Connect to transformer through a 121 Ω , 1% resistor.
TNR	51	O	Transmit Negative Rail for S/T-Interface. Negative output of S/T-interface analog transmitter. Connect to transformer through a 121 Ω , 1% resistor.
RPR	55	I	Receive Positive Rail for S/T-Interface. Positive input of S/T-interface analog receiver. Connect to transformer through a 10 k Ω , 10% resistor.
RNR	56	I	Receive Negative Rail for S/T-Interface. Negative input of S/T-interface analog receiver. Connect to transformer through a 10 k Ω , 10% resistor.

Table 2. U-Interface Pins (7)

Pin Name	Pin #	Type	Pin Description
LOP	68	O	Line Driver Positive Output for U-Interface. Connect to U-interface transformer through a 16.9 Ω , 1% resistor.
LON	65	O	Line Driver Negative Output for U-Interface. Connect to U-interface transformer through a 16.9 Ω , 1% resistor.
VRP	61	—	Positive Voltage Reference for U-Interface Circuits. Connect a 0.1 μ F, 20% capacitor to GND _A (as close to the device pins as possible).
VRN	60	—	Negative Voltage Reference for U-Interface Circuits. Connect a 0.1 μ F, 20% capacitor to GND _A (as close to the device pins as possible).
VRCM	62	—	Common-Mode Voltage Reference for U-Interface Circuits. Connect a 0.1 μ F, 20% capacitor to GND _A (as close to the device pins as possible).
SDINN	64	I	Sigma-Delta A/D Negative Input for U-Interface. Connect via an 820 pF, 20% capacitor to SDINP.
SDINP	63	I	Sigma-Delta A/D Positive Input for U-Interface. Connect via an 820 pF, 20% capacitor to SDINN.

4 Pin Information (continued)

Table 3. GCI+ Pins (5)

Pin Name	Pin #	Type*	Pin Description
DU	33	I	Data Upstream. GCI+ data input.
DD (RCLKEN)	32	OD (O)	Data Downstream. GCI+ data output. Open-drain [†] output (typical). 80 kHz Receive Clock. When the TEST pin is asserted, this pin assumes the alternate function RCLKEN. This output is a buffered version of the internal 80 kHz baud clock that is locked to the received data on the U-interface (or free-running if the U-interface is inactive).
DCL (K2_512)	29	O (O)	GCI Data Clock. Rate defined by GCCF[GRATE(1:0)]. K2_512K Clock. When the TEST pin is asserted, this pin assumes the alternate function K2_512. This is the 512 kHz internal data clock from the U block, and is synchronous to the received data on the U-interface.
FS1 (K2_F)	30	O (O)	Programmable Frame Sync 1. Envelope of channel #0 (GCI mode) or frame sync pulse for B1 channel (TDM mode). See Table 28. K2_Frame Clock. When the TEST pin is asserted, this pin assumes the alternate function K2_F. This is the 8 kHz frame clock from the U block, and is synchronous to the received data on the U-interface.
FS2 (ILOSS)	34	O (I ^d)	Programmable Frame Sync 2. Frame sync pulse for B2 channel. See Table 28. Insertion Loss. When the TEST pin is asserted, this pin assumes the alternate function ILOSS. The ILOSS pin causes the device to continuously transmit an SN1 pattern. This is useful for performing certain tests such as power spectral density. Internal 50 kΩ pull-down. 0: No effect on device operation. 1: U transmitter sends SN1 tone continuously.

* OD = open-drain output, I^d = input with an internal 50 kΩ pull-down.

† Depending on the setting of register bit GCCF[GDRIVER], this output can be programmed to either open drain or push-pull.

4 Pin Information (continued)

Table 4. GPIO Pins (24)

Pin Name	Pin #	Type*	Pin Description
GPIO0.0	72	I ^U /O	General-Purpose Programmable I/O Port 0. All of these pins may be configured as inputs or outputs (see register GPDIR0). When programmed as inputs, GPIO0.[3:0] may be configured as level or edge-triggered interrupt sources for the 80C32 block (see register GPLEI). GPIO0.[3:0] have Schmitt trigger input buffers. Internal 100 kΩ pull-up. GPIO0.[7:6] and [5:4] may be alternatively configured (see register GPAF0) as outputs from PWM modules 1 and 0, respectively.
GPIO0.1	73	I ^U /O	
GPIO0.2	74	I ^U /O	
GPIO0.3	75	I ^U /O	
GPIO0.4 [PWMO00]	76	I ^U /O	
GPIO0.5 [PWMO01]	77	I ^U /O	
GPIO0.6 [PWMO10]	78	I ^U /O	
GPIO0.7 [PWMO11]	79	I ^U /O	
GPIO1.0	81	I ^U /O	
GPIO1.1	82	I ^U /O	
GPIO1.2	83	I ^U /O	
GPIO1.3	84	I ^U /O	
GPIO1.4 (USSP_E)	85	I ^d /O	
GPIO1.5 [T0]	86	I ^U /O	
GPIO1.6 [T1]	87	I ^U /O	
GPIO1.7 [T2]	88	I ^U /O	
GPIO2.0	90	I ^U /O	General-Purpose Programmable I/O Port 2. All of these pins may be configured as inputs or outputs (see register GPDIR2). Internal 100 kΩ pull-up. When programmed as an output, GPIO2.0 has a 6 mA current sinking capability. GPIO2.6 becomes an input to the 8 kHz MTC signal when DOCR[NT-LT] bit is set to 1 (register 0x50). GPIO2.3 may be alternatively configured (see register GPAF1) as the dc/dc output signal SYNCO (see Section 13.1, dc/dc Control Generator Register Set). GPIO2.2 may be alternatively configured (see register GPAF1) as the GCI+ signal FSC (see Section 10, GCI+ Interface Module). GPIO2.1 may be alternatively configured (see register GPAF1) as the GCI+ signal BCLK (see Section 10, GCI+ Interface Module). Pulse Template/Loopback, S-Interface. When the TEST pin is asserted, this pin assumes the alternate function PTLB_S. This input causes the device to perform an S/T-only activation (equivalent to setting SCR0[STOA] = 1), and enables a remote loopback towards the TE on the 2B+D channels (equivalent to setting SCR1[RLB_D, RLB_B2, RLB_B1] = 1). This is useful for performing pulse template and other tests on the S/T-interface. The U-interface should be maintained inactive while this function is enabled.
GPIO2.1 [BCLK]	91	I ^U /O	
GPIO2.2 [FSC]	92	I ^U /O	
GPIO2.3 [SYNCO]	93	I ^U /O	
GPIO2.4	94	I ^U /O	
GPIO2.5	95	I ^U /O	
GPIO2.6 [MTC]	96	I ^U /O	
GPIO2.7 (PTLB_S)	97	I ^U /O	

* I = input, O = output, I^d = input with an internal 50 kΩ pull-down, I^U = input with an internal 100 kΩ pull-up.

4 Pin Information (continued)

Table 5. 80C32 External Access Pins (27)

The 80C32 external access pins change function when the 80C32 block is placed in on-circuit emulation (ONCE) mode (see Section 6.9, On-Circuit Emulation (ONCE) Mode). The following table lists the normal function for each pin or group of pins first, followed by the function when in ONCE mode.

Pin Name	Pin #	Type*	Pin Description
AD[7:0]	11—4	I/O	Multiplexed Low-Order Address/Data Bus. Used when accessing external memory. AD[7:0] are open-drain bidirectional I/O ports requiring external pull-ups.
	—	I/O	<i>ONCE mode.</i> AD[7:0] are inputs in all cases except during the read phase of an internal RAM access, where they become outputs to allow the internal RAM to drive data onto the bus to be read by the emulator.
A[15:8]	20—13	O	Upper Address Bus. Used when accessing external memory. A[15:8] are open-drain, bidirectional I/O ports requiring external pull-ups. In normal mode, they are outputs.
	—	I	<i>ONCE mode.</i> A[15:8] are inputs. If the address is within the range 0K—4K, the chip will execute the read/write operation on the address indicated. The NTN will not respond to addresses above 4K.
ALE	2	O	Address Latch Enable. Output pulse for latching the low byte of the address during an access to external memory. In normal operation, ALE is emitted at a constant rate of 1/6 the oscillator frequency, and can be used for external timing or clocking. Note that one ALE pulse is skipped during each access to external data memory.
	—	I	<i>ONCE mode.</i> ALE is an input that is driven directly by the emulator's ALE signal and is used to latch the address applied on A[15:7], AD[7:0].
$\overline{\text{PSEN}}$	1	O	Program Store Enable (Active-Low). Read strobe output to external program memory. When the 80C32 is executing code from external program memory, $\overline{\text{PSEN}}$ is activated twice each machine cycle, except that two $\overline{\text{PSEN}}$ activations are skipped during each access to external data memory. $\overline{\text{PSEN}}$ is not activated during fetches from internal program memory.
	—	HZ	<i>ONCE mode.</i> $\overline{\text{PSEN}}$ is 3-stated.
$\overline{\text{RD}}$	27	O	Read Strobe (Active-Low). External data memory read strobe output.
	—	I	<i>ONCE mode.</i> $\overline{\text{RD}}$ is an input that is driven directly by the emulator's ALE signal and used to access internal memory locations from 0K—4K. The NTN will not respond to addresses above 4K.
$\overline{\text{WR}}$	28	O	Write Strobe (Active-Low). External data memory write strobe output.
	—	I	<i>ONCE mode.</i> $\overline{\text{WR}}$ is an input that is driven directly by the emulator's ALE signal and used to access internal memory locations from 0K—4K. The NTN will not respond to addresses above 4K.
XINT0	99	I	External Interrupt 0 (Active-Low). Input for driving external interrupt #0 signal on 80C32. This signal is fed to the UCI module where it is combined with the rest of the type 0 interrupts from the internal NTN circuitry (i.e., those in register GIRQ), and the result is presented to the 80C32 INT0_B input.
	—	OD	<i>ONCE mode.</i> Interrupt source 0 output. Open-drain output. The UCI module drives this signal low whenever an internal interrupt type 0 condition occurs.

* I = input, O = output, HZ = high-impedance, OD = open-drain output, I^d = input with an internal 50 kΩ pull-down, I^u = input with an internal 100 kΩ pull-up.

4 Pin Information (continued)

Table 5. 80C32 External Access Pins (27) (continued)

Pin Name	Pin #	Type*	Pin Description
$\overline{\text{XINT1}}$	100	I	External Interrupt 1 (Active-Low). Input for driving external interrupt #1 signal on 80C32. This signal is fed to the UCI module where it is collapsed with the rest of the type 1 interrupts from the internal NTN circuitry (i.e., those in register GIR1), and the result is presented to the 80C32 INT1_B input.
	—	OD	<i>ONCE mode.</i> Interrupt source 1 output. Open-drain output. The UCI module drives this signal low whenever an internal interrupt type 1 condition occurs.
CLKO	24	O	Microcontroller Clock Output. Outputs clock based on settings in register UPCR (see Section 6.7, Clock Generator).
	—	O	<i>ONCE mode.</i> Same behavior as in normal mode. Can be used to supply clock to external emulator.
$\overline{\text{SLP}}$	21	I ^U	Internal Microsleep Input (Active-Low). Activates ONCE mode when $\overline{\text{SLP}}$ is low upon an exit from RESET. Internal 100 k Ω pull-up.
	—	I ^U	<i>ONCE mode.</i> Same behavior as in normal mode. Internal pull-up.
RXD	26	I ^d	80C32 Serial Input Port. Connected directly to P3.0 of 80C32 block. Can also be used as a programmable I/O by appropriate programming of the SFR direction register DIR3 and the SFR port register P3. Internal 50 k Ω pull-down.
	—	HZ	<i>ONCE mode.</i> RXD is 3-stated.
TXD	23	I ^d	80C32 Serial Output Port. Connected directly to P3.1 of 80C32 block. Can also be used as a programmable I/O by appropriate programming of the SFR direction register DIR3 and the SFR port register P3 (see Section 6.12, Special Instructions for Using the Lucent 80C32 Block). Internal 50 k Ω pull-down.
	—	HZ	<i>ONCE mode.</i> TXD is 3-stated.
$\overline{\text{EA}}$	70	I	External Access (Active-Low). When $\overline{\text{EA}}$ is held high, the microcontroller executes instructions from the internal program memory. Holding $\overline{\text{EA}}$ low forces the microcontroller to execute instructions from external program memory. Internal 100 k Ω pull-up.
	—	I	<i>ONCE mode.</i> Holding $\overline{\text{EA}}$ low disables access to the internal memory in the NTN device.

* I = input, O = output, HZ = high-impedance, OD = open-drain output, I^d = input with an internal 50 k Ω pull-down, I^U = input with an internal 100 k Ω pull-up.

4 Pin Information (continued)

Table 6. Comparators (6)

Pin Name	Pin #	Type*	Pin Description
INP0	46	I	Input Positive, Comparator 0. Connect to 5 V via 1 k Ω .
INN0	45	I	Input Negative, Comparator 0. Connect to GND via 1 k Ω .
INP1	48	I	Input Positive, Comparator 1. Connect to 5 V via 1 k Ω .
INN1	47	I	Input Negative, Comparator 1. Connect to GND via 1 k Ω .
INP2	50	I	Input Positive, Comparator 2. Connect to 5 V via 1 k Ω .
INN2	49	I	Input Negative, Comparator 2. Connect to GND via 1 k Ω .

* I = input.

Table 7. JTAG Pins (4)

Pin Name	Pin #	Type*	Pin Description
JTCK (C1536)	41	I ^U (O)	JTAG TAP Clock. It is recommended that this pin be externally pulled to V _{DD} during normal operation. Internal 100 k Ω pull-up. 15.36 MHz System Clock. When the TEST pin is asserted, this pin assumes the alternate function C1536. This output is a buffered version of the internal 15.36 MHz system clock that is used by the NTN device.
JTMS (TCI)	42	I ^U (O)	JTAG TAP Mode Select. This pin is externally pulled to V _{DD} through approximately 20 k Ω . Internal 100 k Ω pull-up. Test Control In. When the TEST pin is asserted, this pin assumes the alternate function TCI. This pin is used for factory testing. Note: When in test mode, TCI must not be pulled low by the user when not being actively driven.
JTDI (TDI)	40	I ^U	JTAG Serial Data Input. This pin is internally pulled to V _{DD} through approximately 20 k Ω . Internal 100 k Ω pull-up. Test Data In. When the TEST pin is asserted, the GPIO1.7 pin assumes the alternate function TDI. This pin is used for factory testing.
JTDO (TDO)	35	O	JTAG Serial Data Output. Test Data Out. When the TEST pin is asserted, this pin assumes the alternate function TDO. This pin is used for factory testing.

* I = input, O = output, I^U = input with an internal 100 k Ω pull-up.

4 Pin Information (continued)

Table 8. Miscellaneous Pins (2)

Pin Name	Pin #	Type*	Pin Description
RESET	31	I ^d	Reset Input (Active-High). This signal resets the entire device. During RESET, the U transmitter produces 0 V. This puts the U-interface in the QUIET maintenance mode as described in ANS/T1.601 Section 6.5. RESET should be asserted whenever return loss and longitudinal balance measurements are being made on the U-interface. Internal 50 kΩ pull-down.
TEST	43	I ^d	Test Input (Active-High). During normal operation, this signal should be maintained high. Internal 50 kΩ pull-down. Please see Section 15, Test Mode for more details.

* I = input, O = output, I^d = input with an internal 50 kΩ pull-down.

Table 9. Oscillator Pins (2)

Pin Name	Pin #	Type*	Pin Description
XTAL1	37	I	Crystal In. 15.36 MHz oscillator input. When using an external crystal, one of the crystal pins is connected to this pin. This pin may also be driven by an external oscillator with CMOS output levels.
XTAL0	38	O	Crystal Out. 15.36 MHz oscillator output. When using an external crystal, one of the crystal pins is connected to this pin. When using an external oscillator, this pin is left unconnected.

* I = input, O = output.

Table 10. Power and Ground Pins

Pin Name	Pin #	Type	Pin Description
V _{DD}	3, 22, 39, 80	—	Digital Power. 5 V ± 5% power supply pins for digital circuitry.
GND _D	12, 25, 36, 44, 69, 89, 98	—	Digital Ground. Ground leads for digital circuitry.
V _{DDA}	53, 57, 67	—	Analog Power. 5 V ± 5% power supply lead for the analog circuitry.
GND _A	52, 59, 66	—	Analog Ground. Ground leads for analog circuitry.

5 Control Register Memory Space

Table 11. Control Register Memory Space

Register Address	Register Mnemonic	Description	Refer To
0x00	GIR0	Global Interrupt Register 0	Table 12 on page 18
0x01	GIR1	Global Interrupt Register 1	Table 13 on page 19
0x02	GIE	Global Interrupt Enable Register	Table 14 on page 20
0x03	UPCK	Microcontroller Clock Control Register	Table 15 on page 21
0x04	WDT	Microcontroller Watchdog Timer Control	Table 16 on page 22
0x05	DFCF	DFAC Configuration Register	Table 22 on page 33
0x06	DFR	Data Flow Register	Table 23 on page 34
0x07	UCR0	U-Interface Control Register #0	Table 24 on page 35
0x08	UCR1	U-Interface Control Register #1	Table 25 on page 36
0x09	USR0	U-Interface Status Register #0	Table 26 on page 37
0x0A	USR1	U-Interface Status Register #1	Table 27 on page 37
0x0B	ECR0	EOC Control Register 0—Command and Address	Table 28 on page 38
0x0C	ECR1	EOC Control Register 1—Message	Table 29 on page 39
0x0D	ESR0	EOC Status Register 0—Command and Address	Table 30 on page 39
0x0E	ESR1	EOC Status Register 1—Message	Table 31 on page 39
0x0F	SCR0	S-Interface Control Register #0	Table 32 on page 40
0x10	SCR1	S-Interface Control Register #1	Table 33 on page 41
0x11	SSR	S-Interface Status Register	Table 34 on page 42
0x12	MFR0	Multiframe Register, Q-Channel Data	Table 35 on page 43
0x13	MFR1	Multiframe Register, S-Subchannel Data	Table 36 on page 43
0x14	UIR	U-Interface Interrupt Register	Table 37 on page 44
0x15	UIE	U-Interface Enable Register	Table 38 on page 45
0x16	SIR	S-Interface Interrupt Register	Table 39 on page 46
0x17	SIE	S-Interface Enable Register	Table 40 on page 46
0x18	HTCF	HDLC Transmitter Configuration Register	Table 55 on page 58
0x19	HRCF	HDLC Receiver Configuration Register	Table 56 on page 59
0x1A	HTTH	HDLC Transmit FIFO Threshold	Table 57 on page 60
0x1B	HRTH	HDLC Receive FIFO Threshold	Table 58 on page 60
0x1C	HTSA	HDLC Transmit FIFO Space Available	Table 59 on page 61
0x1D	HRDA	HDLC Receive FIFO Data Available	Table 60 on page 61
0x1E	HTX	HDLC Transmit Data	Table 61 on page 61
0x1F	HTXL	HDLC Transmit Data Last Byte	Table 62 on page 62
0x20	HRX	HDLC Receive Data	Table 63 on page 62
0x21	HSCR	HDLC SAPI C/R Bit Mask	Table 64 on page 62
0x22	HSM0	HDLC SAPI Match Pattern 0	Table 65 on page 63
0x23	HTM0	HDLC TEI Match Pattern 0	Table 66 on page 63
0x24	HSM1	HDLC SAPI Match Pattern 1	Table 67 on page 63
0x25	HTM1	HDLC TEI Match Pattern 1	Table 68 on page 64
0x26	HSM2	HDLC SAPI Match Pattern 2	Table 69 on page 64
0x27	HTM2	HDLC TEI Match Pattern 2	Table 70 on page 64
0x28	HSM3	HDLC SAPI Match Pattern 3	Table 71 on page 64
0x29	HTM3	HDLC TEI Match Pattern 3	Table 72 on page 65
0x2A	HSMOD	HDLC SAPI Modifier Register	Table 73 on page 65
0x2B	HTMOD	HDLC TEI Modifier Register	Table 74 on page 66
0x2C	HIR	HDLC Interrupt Register	Table 75 on page 67
0x2D	HIE	HDLC Interrupt Enable 15	Table 76 on page 68
0x2E	GCCF	GCI+ Configuration Register	Table 80 on page 79

5 Control Register Memory Space (continued)

Table 11. Control Register Memory Space (continued)

Register Address	Register Mnemonic	Description	Refer To
0x2F	GCOF1	GCI PFS1 Offset Select	Table 81 on page 80
0x30	GCOF2	GCI PFS2 Offset Select	Table 82 on page 80
0x31	GCDMD	GCI Downstream (Transmit) Monitor Data	Table 83 on page 81
0x32	GCDML	GCI Downstream (Transmit) Monitor Data Last	Table 84 on page 81
0x33	GCUMD	GCI Upstream (Receive) Monitor Data	Table 85 on page 81
0x34	GCDCI	GCI Downstream (Transmit) C/I Data	Table 86 on page 82
0x35	GCUCI	GCI Upstream (Receive) C/I Data	Table 87 on page 82
0x36	GCIR	GCI Interrupt Register	Table 88 on page 83
0x37	GCIE	GCI Interrupt Enable	Table 89 on page 84
0x38	GPDIR0	GPIO Port 0 Pin Direction	Table 90 on page 86
0x39	GPDIR1	GPIO Port 1 Pin Direction	Table 91 on page 87
0x3A	GPDIR2	GPIO Port 2 Pin Direction	Table 92 on page 87
0x3B	GPAF0	GPIO Alternate Function Register #0	Table 93 on page 88
0x3C	GPAF1	GPIO Alternate Function Register #1	Table 94 on page 89
0x3D	GPD0	GPIO Port 0 Data Register	Table 95 on page 89
0x3E	GPD1	GPIO Port 1 Data Register	Table 96 on page 90
0x3F	GPD2	GPIO Port 2 Data Register	Table 97 on page 90
0x40	GPLEI	GPIO Level-Edge-Triggered Interrupt Control	Table 98 on page 90
0x41	GPPOL	GPIO Interrupt Polarity Control	Table 99 on page 91
0x42	GPIR	GPIO Interrupt Register	Table 100 on page 91
0x43	GPIE	GPIO Interrupt Enable	Table 101 on page 92
0x44	PW0CF	Pulse-Width Modulator 0 Configuration	Table 104 on page 100
0x45	PW0VH	Pulse-Width Modulator 0 Pulse-Width Value, High Byte	Table 105 on page 101
0x46	PW0VL	Pulse-Width Modulator 0 Pulse-Width Value, Low Byte	Table 106 on page 101
0x47	PW1CF	Pulse-Width Modulator 1 Configuration	Table 107 on page 102
0x48	PW1VH	Pulse-Width Modulator 1 Pulse-Width Value, High Byte	Table 108 on page 103
0x49	PW1VL	Pulse-Width Modulator 1 Pulse-Width Value, Low Byte	Table 109 on page 103
0x4A	PWIR	Pulse-Width Modulator Interrupt Register	Table 110 on page 103
0x4B	DCCF	dc/dc Configuration Register	Table 111 on page 104
0x4C	CME	Comparator Enable	Table 113 on page 106
0x4D	CMT	Comparator Transition Polarity	Table 114 on page 106
0x4E	CMIR	Comparator Interrupt Register	Table 115 on page 107
0x4F	CMIE	Comparator Interrupt Enable	Table 116 on page 107
0x50	DOCR	Device Operation Control Register	Table 41 on page 47
0x51	B1UP	B1-Channel Upstream Data from GCI to U-Interface	Table 42 on page 47
0x52	B2UP	B2-Channel Upstream Data from GCI to U-Interface	Table 43 on page 48
0x53	B1DN	B1-Channel Downstream Data from GCI to U-Interface	Table 44 on page 48
0x54	B2DN	B2-Channel Downstream Data from GCI to U-Interface	Table 45 on page 48
0x55	Reserved1	Reserved Register for Internal Use	Table 46 on page 49
0x56	Reserved2		Table 47 on page 49
0x57	Reserved3		Table 48 on page 49
0x58	Reserved4		Table 49 on page 50
0x59	Reserved5		Table 50 on page 50
0x5A	Reserved6		Table 51 on page 50
0x5B	Reserved7		Table 52 on page 50
0x5C	Reserved8		Table 53 on page 51
0x5D	Reserved9		Table 54 on page 51

6 Functional Modules

This section covers the functionality of the NTN core modules.

6.1 80C32 Microcontroller Module (80C32 Block)

The NTN IC includes an embedded 80C32 microcontroller, incorporating a 256-byte internal RAM, three 16-bit timer/counters, six interrupt sources, and one serial port I/O.

Typical functions of the microcontroller module are as follows:

- Definition of operation modes for all other NTN modules (U-interface, S/T-interface, etc.)
- Configuration of the 2B+D data flow paths in the DFAC module
- Layer 2 and layer 3 processing of the D channel for POTS calls
- Supervision of the POTS circuitry
- Device power management

6.2 Program Address Space

The on-chip 64K x 8 mask-programmable ROM occupies the full program memory space addressable by the 80C32. The 80C32 addresses this memory via the microcontroller interface (UCI) module.

The internal ROM can be disabled so that code from an external ROM can be executed by tying the \overline{EA} pin low. The microcontroller then fetches the program instructions through its external access port (see Table 5). Applications requiring a larger program space than the 64K x 8 available with the standard 80C32 may use GPIO ports to extend the address space using a paging scheme.

6.3 Data Address Space

The NTN data address space is comprised of several distinct regions as shown in Figure 3.

The 80C32 internal RAM is an integral part of the 80C32 architecture and is accessed using the 80C32 MOV instruction (see any standard 80C32 data sheet for details on the internal memory space).

The NTN has on-chip registers and SRAM that occupy the lowest 4 Kbytes of the 80C32's external data memory address space and is accessed using the 80C32

MOVX instruction. The on-chip read and write signals from the 80C32 (shown in Figure 3 as \overline{RD}_i and \overline{WR}_i) are asserted during access to this memory space. The lowest 94 bytes of the 80C32 external space (00—5Dh) are comprised of the device configuration and control registers, and the remaining (4002) bytes (5Eh—0FFFh) are comprised of SRAM.

The NTN can also access off-chip RAM up to the 64K address space limit through the external access port (see Table 5). When accessing the 4K on-chip RAM at the bottom of the address space, the on-chip external qualifier function shown in Figure 3 prevents the \overline{RD}_i and \overline{WR}_i signals from propagating to the NTN pins \overline{RD} and \overline{WR} (the pins remain 3-stated). When accessing an address outside the 4K range of the on-chip memory space, the \overline{RD} and \overline{WR} signals appear on the NTN pins \overline{RD} and \overline{WR} . The external qualifier function eliminates the need for any external decoding (chip-select) logic when an external RAM is being used. In this scheme, the lowest 4K of any external RAM is not usable. External address decoding logic may be used if it is desirable to use the lowest 4K of the external RAM.

6.4 Timers

Timer 0 and timer 1 can be configured as either independent timers or counters as specified in the 80C32 data sheet. In counter mode, GPIO ports 1.5 and 1.6 may be configured to generate timer 0's and timer 1's trigger sources, respectively (see Section 11, GPIO Ports). Timer 2 can be configured as a timer, a counter, or as a serial baud rate generator. In counter and baud generator mode, GPIO 1.7 may be configured as timer 2's trigger source.

6.5 Interrupts

The 80C32 accepts six interrupt sources. These interrupt sources are interrupt lines \overline{INT}_0 and \overline{INT}_1 (the 80C32 block external interrupts); timer 0, timer 1, and timer 2; and a serial port interrupt.

The NTN has an embedded interrupt controller which collapses a large number of interrupt sources (GPIR, UIR, SIR, PWIR, CMIR, GCIR, and HIR) into the two 80C32 interrupt inputs \overline{INT}_0 and \overline{INT}_1 . Since the interrupt controller can be viewed as an AND function of the NTN interrupt sources, the 80C32 interrupts should be programmed as level-triggered interrupts (TCON.IT0 and TCON.IT1, cleared to 0, the reset default condition).

If external edge-triggered interrupt sources must be interfaces to the NTN, ports GPIO0[3:0] and GPIO1[3:0] can be used.

6 Functional Modules (continued)

6.5 Interrupts (continued)

External pins $\overline{XINT0}$ and $\overline{XINT1}$ are also collapsed in the UCI module. $\overline{XINT0}$ is collapsed into register GIR0 in bit XI0I. $\overline{XINT1}$ is collapsed into register GIR1 in bit XI1I. These interrupts are maskable via the corresponding interrupt enable bits (see register GIE).

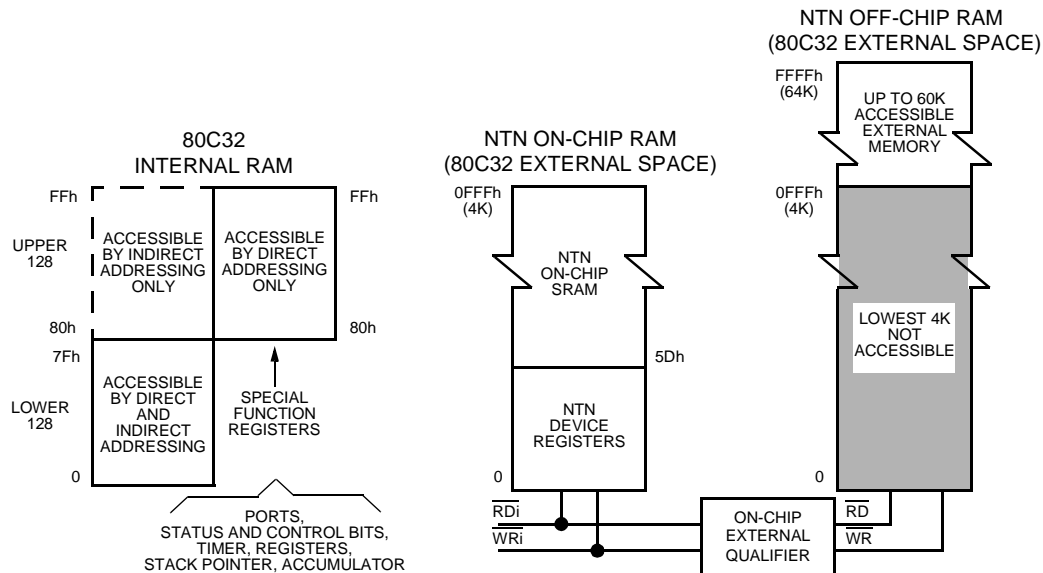

5-6710F.a

Figure 3. NTN Data Memory Address Space

6.6 Interrupt Register Set

Table 12. GIR0: Global Interrupt Register 0 (0x00)

Reg	R/W	Bit 7	Bit 6	Bit 5	Bit 4	Bit 3	Bit 2	Bit 1	Bit 0
GIR0	R	—	—	—	XI0I	125I	UII	SII	GPIOI
RESET	Default	—	—	—	0	0	0	0	0

Note: All bits in this register are set to 1 upon occurrence of the corresponding interrupt condition, and remain set until the interrupt condition causing the interrupt goes away.

Bit	Symbol	Name/Description
7—5	—	Reserved.
4	XI0I	External $\overline{XINT0}$ Interrupt. This interrupt follows the level on the NTN external interrupt pin $\overline{XINT0}$.
3	125I	125 μs Interrupt. This interrupt occurs every 125 μ s. This can be used to program the timing of the microcontroller to access the B-channel data.
2	UII	U-Interface Interrupt. This interrupt occurs when any of the interrupt bits in the U interrupt register (UIR) are active, i.e., all of the U-interface interrupts are collapsed into this bit.
1	SII	S-Interface Interrupt. This interrupt occurs when any of the interrupt bits in the S interrupt register (SIR) are active, i.e., all of the S-interface interrupts are collapsed into this bit.
0	GPIOI	GPIO Interrupt. This interrupt occurs when any of the interrupt bits in the GPIO interrupt register (GPIR) are active, i.e., all of the GPIO interrupts are collapsed into this bit.

6 Functional Modules (continued)

6.6 Interrupt Register Set (continued)

Table 13. GIR1: Global Interrupt Register 1 (0x01)

Reg	R/W	Bit 7	Bit 6	Bit 5	Bit 4	Bit 3	Bit 2	Bit 1	Bit 0
GIR1	R	—	—	—	XI1I	HDLCI	GCII	CMPI	PWMI
RESET	Default	—	—	—	0	0	0	0	0

Note: All bits in this register are set to 1 upon occurrence of the corresponding interrupt condition, and remain set until the interrupt condition causing the interrupt goes away.

Bit	Symbol	Name/Description
7—5	—	Reserved.
4	XI1I	External XINT1 Interrupt. This interrupt follows the level on the NTN external interrupt pin XINT1.
3	HDLCI	HDLC Interrupt. This interrupt occurs when any of the interrupt bits in the HDLC interrupt register (HIR) are active, i.e., all of the HDLC interrupts are collapsed into this bit.
2	GCII	GCI Interrupt. This interrupt occurs when any of the interrupt bits in the GCI interrupt register (GCIR) are active, i.e., all of the GCI interrupts are collapsed into this bit.
1	CMPI	Comparator Interrupt. This interrupt occurs when any of the interrupt bits in the comparator interrupt register (CIR) are active, i.e., all of the comparator interrupts are collapsed into this bit.
0	PWMI	PWM Interrupt. This interrupt occurs when any of the interrupt bits in the PWM interrupt register (PWIR) are active, i.e., all of the PWM interrupts are collapsed into this bit.

6 Functional Modules (continued)

6.6 Interrupt Register Set (continued)

Table 14. GIE: Global Interrupt Enable Register (0x02)

This register contains enable bits for the interrupts in registers GIR0 and GIR1.

Reg	R/W	Bit 7	Bit 6	Bit 5	Bit 4	Bit 3	Bit 2	Bit 1	Bit 0
GIE	R/W	—	—	—	125IE	II1E	XI1E	II0E	XI0E
RESET	Default	0	0	0	0	0	0	0	0

Bit	Symbol	Name/Description
7—5	—	Reserved. Program to 0.
4	125IE	125 μs Interrupt Enable. Enables the 125 μ s interrupt. 0: Interrupt disabled. 1: Interrupt enabled.
3	II1E	Internal Interrupt #1 Enable. Enables internal interrupt #1 bits (HDLCI, GCII, CMPI, PWMI). 0: Interrupt disabled. 1: Interrupt enabled.
2	XI1E	External Interrupt #1 Enable. Enables external interrupt XI1I. 0: Interrupt disabled. 1: Interrupt enabled.
1	II0E	Internal Interrupt #0 Enable. Enables internal interrupt #0 bits (BODI, UII, SII, GPIOI). 0: Interrupt disabled. 1: Interrupt enabled.
0	XI0E	External Interrupt #0 Enable. Enables external interrupt XI0I. 0: Interrupt disabled. 1: Interrupt enabled.

6 Functional Modules (continued)

6.7 Clock Generator

This module contains the crystal oscillator, from which it derives clocks to drive the rest of the modules. The microcontroller can execute a self-powerdown by selecting the clock it receives. At powerup, the microcontroller clock defaults to 15.36 MHz. The microcontroller can slow down its own clock by writing to the UPCK register. When the microcontroller is stopped (UPCK[2:0] = 000), any interrupt will immediately set UPCK = 15.36 MHz.

Table 15. UPCK: Microcontroller Clock Control Register (0x03)

Reg	R/W	Bit 7	Bit 6	Bit 5	Bit 4	Bit 3	Bit 2	Bit 1	Bit 0
UPCK	R/W	CLKOE	—	—	—	—	UPCK2	UPCK1	UPCK0
RESET	Default	1	0	0	0	0	1	1	1

Bit #	Symbol	Name/Description
7	CLKOE	External Microcontroller Clock Output Enable. Controls the output driver for the CLKOE signal. 0: Output driver is 3-stated. 1: Output driver is enabled.
6—3	—	Reserved. Program to 0.
2—0	UPCK[2:0]	Microcontroller Clock Value. Programs the frequency of the microcontroller clock as follows: 000: Stops clock (clock is restarted on detection of interrupt). 001: 0.96 MHz. 010: 1.92 MHz. 011: 3.84 MHz. 100: 7.68 MHz. 101: 15.36 MHz. 110: 15.36 MHz. 111: 15.36 MHz.

6 Functional Modules (continued)

6.8 Watchdog Timer

A watchdog timer is implemented using a 16-bit prescaler clocked by the 80C32 microcontroller clock. The prescaler drives a programmable up-counter that provides an additional count multiplication selection and is programmable from 1 to 127. Upon overflow of the up-counter, the entire chip is reset (including the 80C32). Given the 16-bit prescaler (65536 count) and a 1 to 127 multiplication selection, the watchdog time-out ranges can be calculated as follows:

960 kHz 80C32 clock:

Longest: $1/960 \text{ k} \times 65536 \times 127 = 8.670 \text{ s}$

Shortest: $1/960 \text{ k} \times 65536 \times 1 = 68.27 \text{ ms}$

15.36 MHz 80C32 clock:

Longest: $1/15.36 \text{ M} \times 65536 \times 127 = 541.9 \text{ ms}$

Shortest: $1/15.36 \text{ M} \times 65536 \times 1 = 4.267 \text{ ms}$

Note that programming the count multiplication register to 0 initiates an immediate reset of the chip. This is a convenient way to get the 80C32 to do a full system reset.

Table 16 lists the watchdog timer control register bits.

Table 16. WDT: Microcontroller Watchdog Timer Control (0x04)

Reg	R/W	Bit 7	Bit 6	Bit 5	Bit 4	Bit 3	Bit 2	Bit 1	Bit 0
WDT	R/W	WDTE	WDT6	WDT5	WDT4	WDT3	WDT2	WDT1	WDT0
RESET	Default	0	1	1	1	1	1	1	1

Bit #	Symbol	Name/Description
7	WDTE	Watchdog Timer Enable. Enables the watchdog timer function. 0: Watchdog timer disabled. 1: Watchdog timer enabled.
6:0	WDT[6:0]	Watchdog Timer Value. Multiplication selection for the watchdog timer.

6 Functional Modules (continued)

6.9 On-Circuit Emulation (ONCE) Mode

The external access port pin $\overline{\text{SLP}}$ is used to put the device under the control of an external microcontroller. The ONCE mode is invoked by the following two steps:

- Pulling $\overline{\text{SLP}}$ and RESET low.
- Holding $\overline{\text{SLP}}$ low while releasing RESET.

Table 5 lists the functions of the microcontroller's external access pins during ONCE mode.

6.10 Emulation

When using ONCE mode, some special provisions must be made on the target system to ensure accurate emulation as follows:

- If the target system's NTN uses external RAM, a memory decoder must be added to the board to support emulation. This decoder must select the external RAM only during accesses to addresses above the lowest 4K of memory. This is not necessary during normal operation because the NTN disables the $\overline{\text{RD}}$ and $\overline{\text{WR}}$ strobes that are routed to the external memory whenever an access is being made to the internal 4K of RAM. However, during emulation mode, the signals are being driven by the external emulator and will be presented to the external RAM for all external data accesses, including the lowest 4K. This will create contention between the internal 4K of RAM and the lowest 4K of external RAM. As a simple example of required decoding logic, if using an external 4K RAM, the A12 address line could be inverted and used to drive the RAM's $\overline{\text{CS}}$ signal. For an external 8K RAM, the NOR of the A12 and A13 lines could be used to drive $\overline{\text{CS}}$. For an external 16K RAM, the NOR of A12 through A14 could be used to drive $\overline{\text{CS}}$, etc. This logic is not required when using the system in normal (nonemulation) mode.
- If any of the GPIO1.[7:5] pins are being used as inputs to trigger internal timers T2, T1, and T0 (see register GPAF1), these signals must also be routed to the 80C32 emulator's port pins P1.0, P3.5, and P3.4, respectively, in order to trigger the corresponding timers on the emulator.
- External interrupt sources that normally drive $\overline{\text{XINT0}}$ and $\overline{\text{XINT1}}$ should be open-drain drivers to avoid contention with the $\overline{\text{XINT0}}$ and $\overline{\text{XINT1}}$ pins during

ONCE mode. In normal operation, $\overline{\text{XINT0}}$ and $\overline{\text{XINT1}}$ pins on the NTN are inputs with internal pull-ups (thus an external open-drain driver does not require a pull-up). In ONCE mode, the $\overline{\text{XINT0}}$ and $\overline{\text{XINT1}}$ pins become open-drain outputs (with internal pull-ups) so that the NTN can drive the internal status of the $\overline{\text{XINT0}}$ and $\overline{\text{XINT1}}$ signals onto the corresponding emulator pins. Note that this means that, in ONCE mode, the interrupt service routine (ISR) for $\overline{\text{INT0}}$ and $\overline{\text{INT1}}$ will need to be modified to reflect this difference. This is because in normal mode, the microcontroller will see X|0| or X|1| go high in registers GR0 and GR1, respectively, when an external interrupt occurs. However, in ONCE mode, the occurrence of an external interrupt will change the level on the emulator's $\overline{\text{INT0}}$ and $\overline{\text{INT1}}$ pins, but this change will not show up in the X|0| or X|1| interrupt bits in the NTN. Therefore, the ISR will need to assume that, if no bits in GIR0 (for an $\overline{\text{XINT0}}$ interrupt) or GIR1 (for an $\overline{\text{XINT1}}$ interrupt) are set and an interrupt has occurred, then the ISR for the corresponding external interrupt should be invoked.

6.11 Module I/O

The I/O interface for this module is identical to that documented in the Lucent 80C31/32/51/52 data sheet, with the exception of the ALE signal. ALE is also an input to the 80C32 block. This is required to allow an external microcontroller to access the internal 4 Kbytes address space during ONCE mode.

During ONCE mode, there is a direct connection between the external access port signals and their associated signals on the microcontroller interface. For this purpose, a shell was created around the original block. This shell is essentially a set of multiplexers that, during ONCE mode, allows the external port access signals to drive the XDBALE, XDBTI, IOLAD, IOHAD, $\overline{\text{WR}}$, and $\overline{\text{RD}}$ signals on the internal microcontroller interface.

6 Functional Modules (continued)

6.12 Special Instructions for Using the Lucent 80C32 Block

There are some differences in operation between the Lucent 80C32 block and a standard 80C32. Attention must be paid to these differences in order to ensure trouble-free operation.

6.12.1 Port Configuration

The Lucent Technologies 80C32 I/O ports are controlled by a direction register that determines whether the port is an input or output. Normal instruction and data accesses will operate properly without writing to the direction registers. However, in order to use the ports as inputs or outputs, the direction registers must be set accordingly. Writing a 0 to the corresponding bit of the direction register will configure the pin as an output, and the content of the port latch will be driven onto the pin. Writing a 1 to the corresponding bit of the direction register will configure the pin as an input.

The direction registers reside in an unused area of the SFR address space of the 80C32 at the addresses shown in Table 17.

6.12.1.1 Ports 0 and 2

In the NTN, ports 0 and 2 are dedicated to accessing memory, and therefore, no action is required with regard to the setting of the direction control registers.

6.12.1.2 Port 1

Port 1 is not available on the NTN device, with the exception of P1.0, which is used as the timer 2 input when bit GPAF1[GPAF1.7] is set. This is the only allowed use for P1.0 on the NTN device, and therefore, bit 0 in the port 1 direction register must be set to 1 to configure this bit as an input. This is the default on the 80C32 block.

Note that P1.1 is not available on the 80C32 block. Normally, this pin can be used as the T2EX signal for timer 2 on an 80C32. Since this input is not available on the NTN, the timer 2 functions that are normally controlled by the T2EX input are not accessible on the NTN.

Also note that on a standard 80C32, timer 2 has a programmable clock out mode in which P1.0 is used to output a square wave whose frequency is controlled by timer 2. Since P1.0 can only be used as the timer 2 input on the NTN, this mode is not allowed.

6.12.1.3 Port 3

All of the pins on port 3 are used by the NTN device. The following is a summary of the usage requirements for the pins of port 3:

- **P3.1, P3.0.** The NTN device allows P3.1 and P3.0 to be used as general-purpose I/O in addition to their primary purpose of supporting UART connections via the RXD and TXD functions. In this case, the corresponding bits in the port 3 direction register must be set according to the use of the pins.
- **P3.3, P3.2.** The NTN device uses P3.3 and P3.2 as general external interrupt sources XINT1 and XINT0. Therefore, bits 3 and 2 in the port 3 direction register must be set to 1 to configure these bits as inputs.
- **P3.5, P3.4.** The only allowed use for these bits on the NTN device is as the timer 1 and timer 0 inputs (when bits GPAF1[GPAF1.6] and GPAF1[GPAF1.5] are set, respectively). Therefore, bits 5 and 4 in the port 3 direction register must be set to 1 to configure these bits as inputs. This is the default state on the 80C32 block.
- **P3.7, P3.6.** The only allowed use for these bits on the NTN device is as the WR and RD outputs. Since normal instruction and data accesses will operate properly without writing to the direction registers, bits 7 and 6 in port 3 direction register are don't cares.

Table 17. Port Direction Registers

Direction Control Register Port #	SFR Address	Default Value	Default State
Port 0	0xa4	FFh	Input
Port 1	0xa5	FFh	Input
Port 2	0xa6	00h	Output
Port 3	0xa7	FFh	Input

6 Functional Modules (continued)

6.13 Serial Port Timing

As per the *Intel** 80C32 data book, there are two inputs to the UART module, TXclock and RXclock, which control the transmission and reception of serial data, respectively. For each of these inputs, it is possible to independently select either timer 1 or timer 2 as the source. This selection is controlled by the RCLK and TCLK bits in the SFR register T2CON, which controls the mode of operation of timer 2. The RCLK/TCLK options are shown in Table 18.

Table 18. Standard 80C32 RCLK/TCLK Options

RCLK	TCLK	RXclock	TXclock
0	0	timer 1	timer 1
0	1	timer 1	timer 2
1	0	timer 2	timer 1
1	1	timer 2	timer 2

The UART module in the Lucent 80C32 has only one clock input, which is used to control both reception and transmission. This limitation results in the following truth table (Table 19), which illustrates that both RXclock and TXclock must be drawn from the same source, either timer 1 or timer 2, depending on the value selected for TCLK.

Table 19. Lucent 80C32 RCLK/TCLK Options

RCLK	TCLK	RXclock	TXclock
0	0	timer 1	timer 1
1	1	timer 2	timer 2

The only cases impacted are cases where the UART transmission and reception functions have to be performed with different clocks. Completely independent selection of RXclock and TXclock is not possible, as is seen by comparing Table 18 and Table 19.

* *Intel* is a registered trademark of Intel Corporation.

6 Functional Modules (continued)

6.14 External Program Memory Characteristics

Table 20. External Program Memory Characteristics (Use with Figure 4 through Figure 6.)

Each timing symbol has five characters. The first character is always a T (time). The other characters, depending on their positions, stand for the name of a signal or the logical status of that signal. The following list identifies each character:

Character	Meaning	Character	Meaning
A	Address	Q	Output data
C	Clock	R	\overline{RD} signal
D	Input data	T	Time
H	Logic level high	V	Valid
I	Instruction (program memory contents)	W	\overline{WR} signal
L	Logic level low, or ALE	X	No longer a valid logic level
P	\overline{PSEN}	Z	Float

$T_A = 0\text{ }^\circ\text{C}$ to $70\text{ }^\circ\text{C}$, $V_{CC} = 5\text{ V} \pm 10\%$; $V_{SS} = 0\text{ V}$; load capacitance for port 0, ALE, and $\overline{PSEN} = 100\text{ pF}$; load capacitance for all other outputs = 80 pF .

Symbol	Parameter	Min	Max	Unit
1/TCLCL	Oscillator Frequency	—	15.36	MHz
TAVDV	Address Valid to Valid Data In	—	$9TCLCL - 100$	ns
TAVIV	Address Valid to Valid Instruction In	—	$3TCLCL - 100$	ns
TAVLL	Address Valid to ALE Low	$TCLCL - 40$	—	ns
TAVWL	Address to \overline{RD} or \overline{WR} Low	$4TCLCL - 40$	—	ns
TLHLL	ALE Pulse Width	$2TCLCL - 40$	—	ns
TLLAX	Address Hold After ALE Low	$TCLCL - 35$	—	ns
TLLDV	ALE Low to Valid Data In	—	$8TCLCL - 100$	ns
TLLIV	ALE Low to Valid Instruction In	—	$4TCLCL - 100$	ns
TLLPL	ALE Low to \overline{PSEN} Low	$TCLCL - 25$	—	ns
TLLWL	ALE Low to \overline{RD} or \overline{WR} Low	$3TCLCL - 50$	$3TCLCL + 50$	ns
TPLAZ	\overline{PSEN} Low to Address Float	—	20	ns
TPLIV	\overline{PSEN} Low to Valid Instruction In	—	$3TCLCL - 100$	ns
TPLPH	\overline{PSEN} Pulse Width	$3TCLCL - 40$	—	ns
TPXAV	\overline{PSEN} to Address Valid	$TCLCL - 8$	—	ns
TPXIX	Instruction Hold After \overline{PSEN}	0	—	ns
TPXIZ	Instruction Float After \overline{PSEN}	—	$TCLCL - 20$	ns
TQVWH	Data Valid to Write High	$7TCLCL - 100$	—	ns
TQVWX	Data Valid to Write Transition	$TCLCL - 50$	—	ns
TRHDX	Data Hold After \overline{RD}	0	—	ns
TRHDZ	Data Float After \overline{RD}	—	$2TCLCL - 50$	ns
TRLAZ	\overline{RD} Low to Address Float	—	20	ns
TRLDV	\overline{RD} Low to Valid Data In	—	$5TCLCL - 100$	ns
TRLRH	\overline{RD} Pulse Low	$6TCLCL - 50$	—	ns
TWHLH	\overline{RD} or \overline{WR} High to ALE High	$TCLCL - 40$	$TCLCL + 40$	ns
TWHQX	Data Hold After \overline{WR}	$TCLCL - 50$	—	ns
TWLWH	\overline{WR} Pulse Low	$6TCLCL - 50$	—	ns

6 Functional Modules (continued)

6.14 External Program Memory Characteristics (continued)—

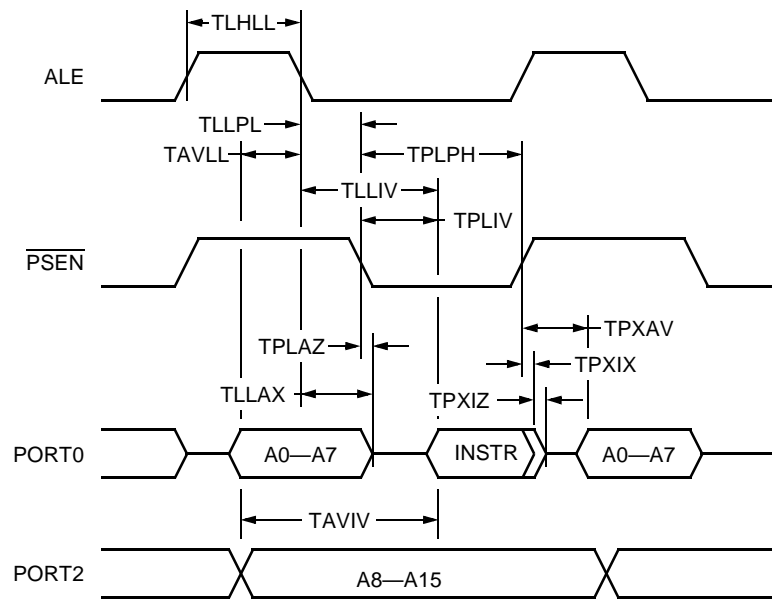

5-8335(F)

Figure 4. External Program Memory Read Cycle

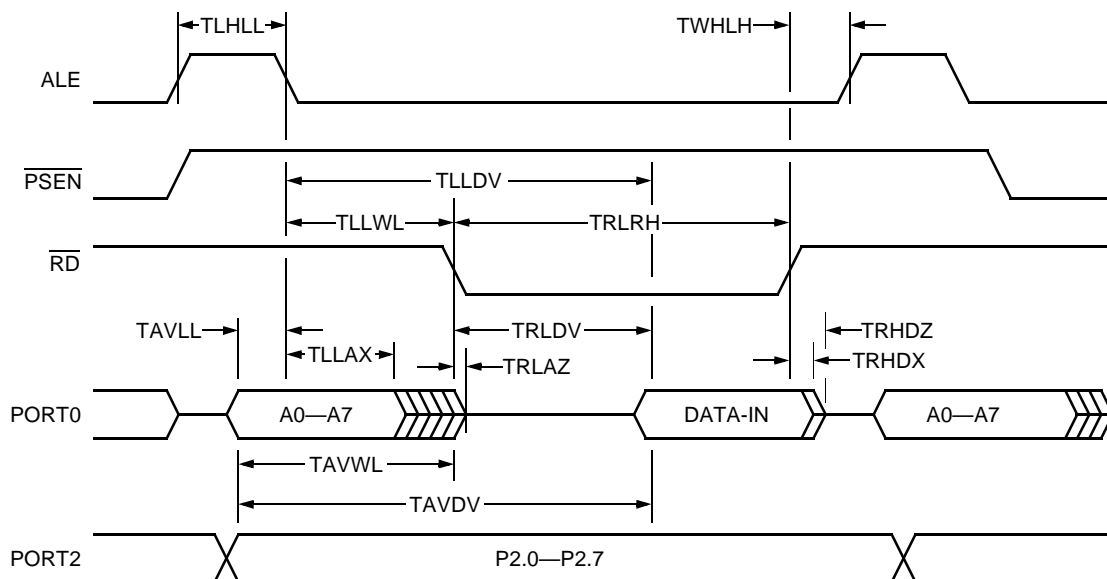

5-8336(F)

Figure 5. External Data Memory Read Cycle

6 Functional Modules (continued)

6.14 External Program Memory Characteristics (continued)

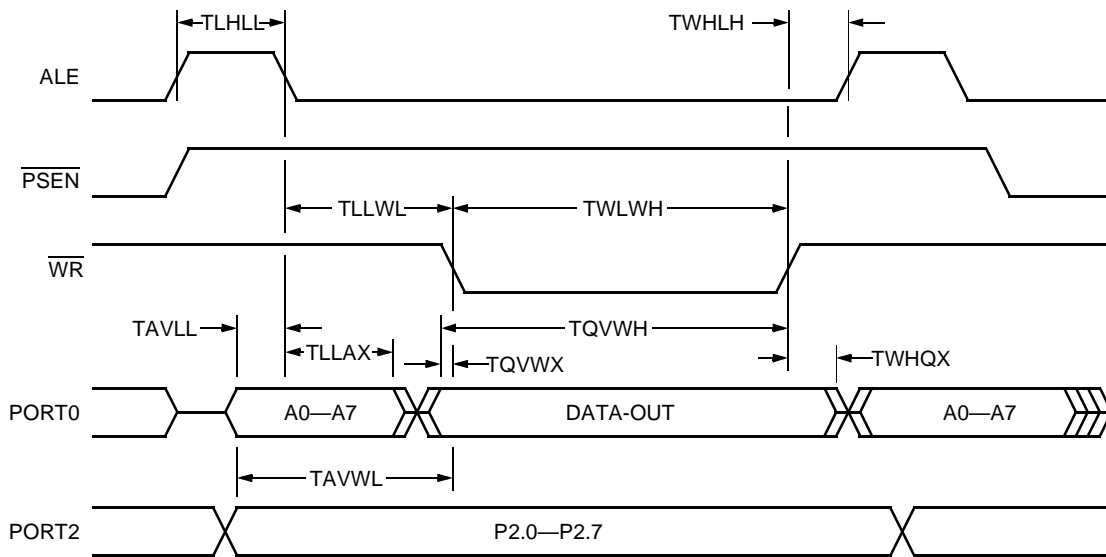

5-8334(F)

Figure 6. External Data Memory Write Cycle

7 Transmission Superblock

The transmission superblock (TSB) contains all the modules that are directly involved in the transmission of data to/from the S, U, HDLC, or GCI+ interfaces. It is comprised of the following modules (contained in a box labeled Transmission Superblock in Figure 1).

- U block—This module provides the NT-mode and LT-mode U-interface function.
- S block—This module provides the NT-mode S/T-interface function.
- Data Flow/Activation Control (DFAC)—This module manages the data flow between the U, S, HDLC, and GCI+ interfaces. In addition, it serves as the central control element for activation/deactivation of the S and U blocks, and implements the embedded operation channel (EOC) processing state machine.
- HDLC—This module provides the HDLC controller function for D-channel access.
- GCI+—This module provides the GCI+ interface for external components such as codecs.

7.1 U-Interface Block (U Block)

The ISDN U-interface block offers the following features:

- Conforms to ETSI TS 080 and ANS/T1.601 standards in both LT and NT operation.
- Meets loop range requirement per the *British Telecom** specification BT RC7355D.
- Single pulse and ILOSS output modes for test support.
- Manual/auto activation, manual/auto dying gasp (power status indication), and manual/auto activation of the EOC control.
- M4 control and status bits incorporate 3x (trinal) bit filtering.

The primary interface to this block is provided via the DFAC module (see Section 7.3, Data Flow/Activation Control Module (DFAC)). A bank of registers contained in the DFAC module defines the operation of the U-interface.

* *British Telecom* is a trademark of British Telecommunications plc.

7.2 S/T-Interface Block (S Block)

The ISDN S/T-interface block offers the following features:

- Conforms to ITU-T I.430, ETSI 300-012, and ANS/T1.605 standards for the network termination (NT) side of the network.
- Fixed/adaptive timing modes under microcontrol, or pin control, defaulting to adaptive timing from a reset state.
- Provides knowledge of the S/T-interface activation state to the microcontroller by supplying INFO-1 and INFO-3 state information.
- Manual/auto activation, multiframing (S and Q channels), and POTS D-channel contention resolution.
- Microcontrolled powerdown feature supports a scan mode that looks for activity on the S/T-interface.
- Supports point-to-point and multipoint arrangement.

Data to/from this block is provided by/to the DFAC. A bank of registers contained in the DFAC module defines the operation of the S/T-interface.

7 Transmission Superblock (continued)

7.3 Data Flow/Activation Control Module (DFAC)

This module provides the following functions:

- S/T-interface and U-interface activation/deactivation control.
- U-interface management.
 - M4 bit filtering.
 - Automatic/manual EOC channel control.
 - Register interface.
 - Activation/deactivation management.
- S/T-interface management.
 - Register interface.
 - Activation/deactivation management.
- Data flow functions:
 - Mapping of B1-, B2-, and D-channel data between S/T bus and U bus.
 - Mapping of D-channel data between the HDLC transmitter module and the U bus.
 - Mapping of B1- and B2-channel data between the GCI+ interface and the U bus.

7.3.1 EOC State Machine (EOCSM)

EOCSM module processes the downstream EOC. The received EOC data/message is transferred to the microcontroller. The upstream EOC channel may be directly controlled by the microcontroller (DFCF[AUTOEOC = 0]) or automatically generated by the EOCSM as shown in Figure 7.

7.3.2 Automatic EOC (AUTOEOC) Mode

In the automatic EOC (AUTOEOC) mode, the downstream EOC messages are interpreted and acted upon by the NTN with no need for microcontroller intervention. The appropriate upstream response is automatically generated.

The set of EOC messages supported by the NTN are those defined in ETSI TS 080 and *ANSI T1.601*, and are shown in Table 21.

7.3.3 Manual EOC Mode

In the manual EOC mode, the microcontroller is responsible for interpreting the downstream EOC message, taking the appropriate action, and responding correctly in the upstream direction.

In both manual and AUTOEOC modes, the NTN stores the most recent downstream EOC contents in registers ESR0 and ESR1. The microcontroller can be interrupted on either a single change in the EOC contents (see bit UIR[EOCSC]) or a trinal-checked change in the EOC contents (see bit UIR[EOC3SC]). Actions in response to the standard set of messages shown in Table 21 can be taken by writing to register ECR0[7:4]. The microcontroller writes the upstream EOC response to registers ECR0[3:0] and ECR1[7:0]. The half-superframe interrupt UIR[RHSF] can be used to determine the correct EOC message timing.

All actions are latched, permitting multiple EOC-initiated actions to be in effect simultaneously. The transition of transmission system through either receiver reset or full reset states releases all the outstanding EOC-controlled operations, and resets the EOC processor to return-to-normal.

7 Transmission Superblock (continued)

7.3 Data Flow/Activation Control Module (DFAC) (continued)

7.3.3 Manual EOC Mode (continued)

Table 21. AUTOEOC = 1 Messages (Data/Messages = 1) That Initiate Actions

Message Code	Message
0101 0000	Operate 2B+D Loopback
0101 0001	Operate B1 Loopback
0101 0010	Operate B2 Loopback
0101 0011	Request Corrupted CRC
0101 0100	Notify of Corrupted CRC
1111 1111	Return to Normal
0000 0000	Hold State

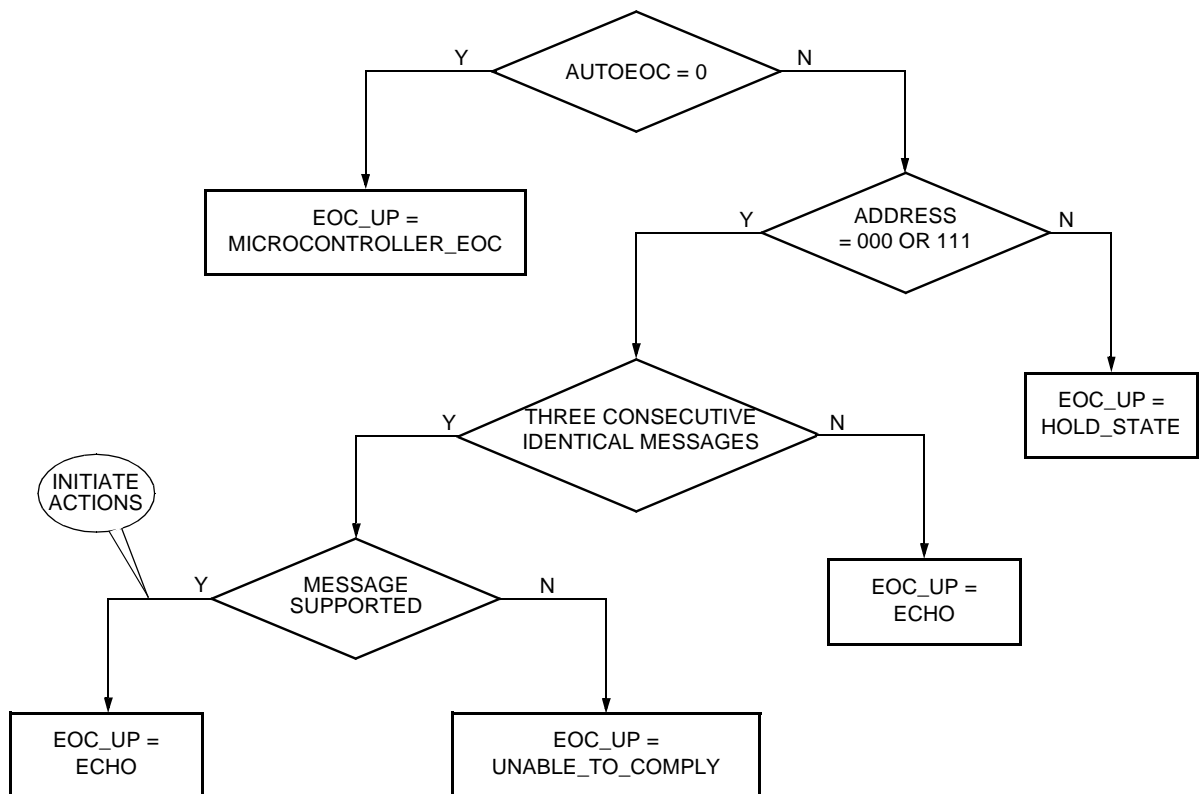

Note: EOC_UP = EOC upstream contents. EOC_DN = EOC downstream contents.

5-6505bF

Figure 7. Downstream EOC Analysis (AUTOEOC = 1) and Upstream EOC Processing

7 Transmission Superblock (continued)

7.3 Data Flow/Activation Control Module (DFAC) (continued)

7.3.4 Data Flow Control

Figure 8 shows the high-level view of the 2B+D data flow. The downstream buffer (DB) and upstream buffer (UB) submodules control the downstream and upstream paths, respectively.

When the B-channel data flow is configured to be between the U-interface and the GCI interface, the corresponding S/T-interface channel is disabled. The converse is also true, i.e., when the data flow is between the S- and U-interfaces, the corresponding GCI+ interface channel is disabled. The D-channel packets are never passed to the GCI interfaces.

All D-channel packets are passed to the S/T-interface. The packets are passed to the HDLC module depending on the address recognition configuration, see Section 9.3, HDLC Receiver.

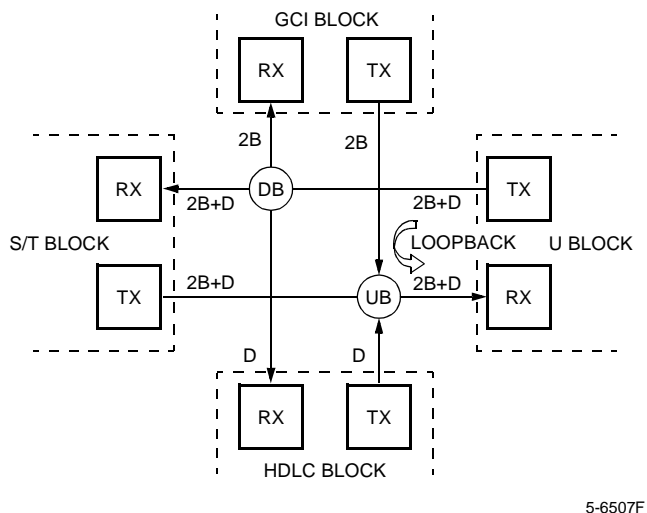

5-6507F

Figure 8. 2B+D Data Flow Block Diagram

7.4 Microcontroller Access to Upstream and Downstream B1 and B2 Channels

The microcontroller can write into B1UP register 51h the content it wants to be transferred on the U-interface upstream B1 channel (assuming $DFR[U_FORCE_B1UP] = DFR[B1_SEL] = 1$ and $ECR0[LB1] = 0$). In this way, the microcontroller can process the upstream GCI information (such as implementing a bit-robbing algorithm on pair-gain applications).

Similarly, the content of the U-interface downstream B1 channel is available to the microcontroller by reading B1DN register 53h. The microcontroller can break the normal data flow from U-interface to GCI, by writing into the B1DN register the content it wants to be sent to the GCI downstream B1 channel (assuming that $GCOF2[U_FORCE_B1DN] = DFR[B1_SEL] = 1$ and $ECR0[LB1] = 0$).

The B1UP register (51h) and B1DN register (53h) are both read/write registers. Hence, data can be read from these registers and also written into them for transmitting in the proper direction.

The microcontroller can write into B2UP register 52h the content it wants to be transferred on the U-interface upstream B2 channel (assuming $DFR[U_FORCE_B2UP] = DFR[B2_SEL] = 1$ and $ECR0[LB2] = 0$).

Similarly, the content of the U-interface downstream B2 channel is available to the microcontroller by reading B2DN register 54h. The microcontroller can break the normal data flow from U-interface to GCI, by writing into the B2DN register the content it wants to be sent to the GCI downstream B2 channel (assuming that $GCOF2[U_FORCE_B2DN] = DFR[B2_SEL] = 1$ and $ECR0[LB2] = 0$).

The following table summarizes the microcontroller access to upstream and downstream B1 and B2 channels:

BxUP	W	R
BxDN	R	W
U_FORCE_BxUP	1	0
U_FORCE_BxDN	0	1
Action	B-channels on the U-interface are accessed. Upstream registers are write only, downstream registers are read only.	B-channels on the GCI/TDM registers are accessed. Upstream registers are read only, downstream registers are write only.

$DFR[PFSx_ACT]$ and $DFR[Bx_SEL]$ need to be set to 1 and $ECR0[LBx]$ needs to be set to 0 in order to activate these functions.

7.5 LT Mode

The T9000 device can also be operated in LT mode. Setting the register bit $DOCR[NT_LT]$ to 1 changes the T9000 from NT operational mode to LT operational mode.

When the device is operating in LT mode, an 8 kHz master transmit clock (MTC) must be provided as an input on GPIO2.6.

7 Transmission Superblock (continued)

7.6 DFAC Register Set

Table 22. DFCF: DFAC Configuration Register (0x05)

Reg	R/W	Bit 7	Bit 6	Bit 5	Bit 4	Bit 3	Bit 2	Bit 1	Bit 0
DFCF	R/W	ILOSS	USIMRST	URESET	—	UOADS	ACT_ANSI	AUTOEOC	GRESET
RESET	Default	0	0	0	0	1	0	1	0

Bit	Symbol	Name/Description
7	ILOSS	Insertion Loss Test Control. Causes the U-interface transmitter to continuously transmit the sequence SN1. The U-interface transceiver remains reset during this mode. 0: No effect on device operation. 1: U transmitter sends SN1 tone continuously.
6	USIMRST	Special Simulation Reset for U-Block. This signal causes assertion of a special reset that is used for factory testing of the U block. This bit should always be programmed to 0. 0: No effect on device operation. 1: U-block simulation reset (nonlatching-value readback will always be 0).
5	URESET	U Transceiver Reset. Assertion of this bit halts U-interface data transmission and clears adaptive filter coefficients. During URESET, the U transmitter produces 0 V. The microcontroller may use this bit to put the U-interface in a quiet mode for maintenance as described in <i>ANSI/T1.601</i> Section 6.5. In addition, this bit should be asserted whenever return loss and longitudinal balance measurements are being made on the U-interface. 0: No effect on device operation. 1: U block is held in reset (nonlatching-value readback will always be 0).
4	—	Reserved. Program to 0.
3	UOADS	UOA Default State. During activation, the bits UOA_n and OOF_n become transparent at the same time (at U-interface synchronization time), but UOA_n is filtered for three occurrences before being acted upon, and hence, a direct transition to the UOA state is not possible. To satisfy this ETSI ETR 080 requirement, the UOADS bit allows the NTN to default to the presynchronization value of UOA_n to 0. Upon synchronization, if UOADS = 0 is received, a transition to the UOA state occurs, because the 3-time filtering criteria is satisfied. UOADS defaults to 1, meaning that U-only activation, at start-up, causes the U-interface to fully synchronize and then a transition to the UOA state occurs. It is recommended that UOADS be programmed to 1.
2	ACT_ANSI	ACT Mode Select. Controls the state of the transmitted ACT bit when an EOC loopback 2 (2B+D) is requested. The loopback occurs automatically if AUTOEOC bit is set. Otherwise, bit U2BDLT must be set to 0. 0: ACT = 1 during loopback 2 after INFO3 is recognized at the S/T-interface (per ETSI ETR 080). The data received by the NT is not looped back towards the LT until after ACT = 1 is received from the LT. Prior to this time, 2B+D data toward the LT is all 1s. 1: ACT = 0 during loopback 2 (per <i>ANSI/T1.601</i>). The data received at the NT is looped back towards the LT as soon as the 2B+D loopback is enabled.
1	AUTOEOC	Automatic EOC Processor Enable. Enables EOC state machine which implements EOC processing per ETSI ETR 080 (see Section 7.3.1, EOC State Machine (EOCSM) for details on the EOC state machine operation). The EOC state machine only responds to the addresses 000 and 111 as valid addresses. 0: EOC state machine disabled. 1: EOC state machine enabled.
0	GRESET	Global Software Reset. Assertion of this bit resets all internal modules except the 80C32 to their default states. U-macro adaptive filter coefficients are cleared. Since performing a GRESET also resets this bit to its default state, it is not necessary to write it back to a 0 after writing a 1. 0: No effect on device operation. 1: Reset all circuitry except internal 80C32.

7 Transmission Superblock (continued)

7.6 DFAC Register Set (continued)

Table 23. DFR: Data Flow Register (0x06)

Reg	R/W	Bit 7	Bit 6	Bit 5	Bit 4	Bit 3	Bit 2	Bit 1	Bit 0
DFR	R/W	U_FORCE_B2UP	U_FORCE_B1UP	FORCE_D	PFS2_ACT	PFS1_ACT	B2_SEL	B1_SEL	BSWAP
RESET	Default	0	0	0	0	0	0	0	0

Bit #	Symbol	Name/Description
7	U_FORCE_B2UP	Microcontroller Access to Upstream B2 Channel. When this bit is set, the microcontroller can access the upstream B2-channel data from the GCI to the U-interface via the register B2UP (0x52) assuming that DFR[B2_SEL] = 1 and ECR0[LB2] = 0.
6	U_FORCE_B1UP	Microcontroller Access to Upstream B1 Channel. When this bit is set, the microcontroller can access the upstream B1-channel data from the GCI to the U-interface via the register B1UP (0x51) assuming that DFR[B1_SEL] = 1 and ECR0[LB1] = 0.
5	FORCE_D	Force Local D-Channel Access. When this bit is asserted, D-channel arbitration is disabled and upstream access to the D channel is granted exclusively to the local HDLC controller. 0: Normal operation. Upstream D-channel arbitration is automatically provided (with an equal priority) between the local HDLC controller and the upstream D channel from the S/T-interface. 1: Upstream D-channel access is granted exclusively to the HDLC controller.
4	PFS2_ACT	Programmable Frame Strobe-2 Output Enable on GCI+ Interface. See Section 10, GCI+ Interface Module for detailed information. 0: Function PFS2 is disabled. FS2 output drives a zero level. Data downstream (DD) pin is 3-stated during the corresponding time slot. 1: PFS2 is enabled.
3	PFS1_ACT	Programmable Frame Strobe-1 Output Enable on GCI+ Interface. See GCI+ section for detailed information. 0: Function PFS1 is disabled. In TDM mode, FS1 output drives a zero level. In GCI mode, GPIO2.2 drives a zero level (assuming GPAF1[GPAF2.2] = 1). Data downstream (DD) pin is 3-stated during the corresponding time slot. 1: PFS1 is enabled and will be output on pin FS1 (in TDM mode) or GPIO2.2 (in GCI mode, assuming GPAF1[GPAF2.2] = 1).
2	B2_SEL	U-Interface B2-Channel Source/Destination. 0: U-interface B2 channel to/from S/T-interface. 1: U-interface B2 channel to/from GCI+ interface (or microcontroller if U_FORCE_B2UP is set).
1	B1_SEL	U-Interface B1-Channel Source/Destination. 0: U-interface B1 channel to/from S/T-interface. 1: U-interface B1 channel to/from GCI+ interface (or microcontroller if U_FORCE_B1UP is set).
0	BSWAP	B-Channel Swap on GCI+ Interface. No effect on device operation unless either B1_SEL = 1 or B2_SEL = 1. See GCI+ interface section for details on the assignment of B channels to GCI+ time slots. 0: Normal operation. 1: When B1_SEL = 1, the U-interface B1 channel source/destination is the channel on which the B2 channel is assigned on the GCI+ interface. When B2_SEL = 1, the U-interface B2-channel source/destination is the channel on which the B1 channel is assigned on the GCI+ interface.

7 Transmission Superblock (continued)

7.6 DFAC Register Set (continued)

Table 24. UCR0: U-Interface Control Register #0 (0x07)

Reg	R/W	Bit 7	Bit 6	Bit 5	Bit 4	Bit 3	Bit 2	Bit 1	Bit 0
UCR0	R/W	NTM_n	PS1	PS2	SAI	XPCY	F_ACTUP	ACTUP	ISTP
			DEA		UOA		F_ACTDN	ACTDN	
RESET	Default	1	1	1	0	0	0	0	0

Bit #	Symbol	Name/Description															
7	NTM_n	NT Test Mode. Controls upstream U-interface overhead bit NTM. 0: NTM = 0, Indicates the NT is in test mode. 1: NTM = 1, Normal operation.															
6	PS1	Power Status 1. Controls upstream U-interface overhead bit PS1. (See PS2 below.)															
	DEA	Deactivate. When the T9000 device is put in LT mode (DOCR[NT_LT] = 1), this bit becomes the DEA (turn-off) bit.															
5	PS2	Power Status 2. Controls upstream U-interface overhead bit PS2. According to ETSI ETR 080, PS1 and PS2 indicate the NT power status as follows: <table border="1"> <thead> <tr> <th>PS1</th> <th>PS2</th> <th>Power Status</th> </tr> </thead> <tbody> <tr> <td>0</td> <td>0</td> <td>Dying gasp.</td> </tr> <tr> <td>0</td> <td>1</td> <td>Primary power out.</td> </tr> <tr> <td>1</td> <td>0</td> <td>Secondary power out.</td> </tr> <tr> <td>1</td> <td>1</td> <td>All power normal.</td> </tr> </tbody> </table>	PS1	PS2	Power Status	0	0	Dying gasp.	0	1	Primary power out.	1	0	Secondary power out.	1	1	All power normal.
PS1	PS2	Power Status															
0	0	Dying gasp.															
0	1	Primary power out.															
1	0	Secondary power out.															
1	1	All power normal.															
4	SAI	S/T-Interface Activity Indicator Control. Controls upstream U-interface overhead bit SAI. According to ETSI ETR 080, the SAI bit is set to 1 to indicate to the network that there is activity (INFO 1 or INFO 3) at the S/T reference point. Otherwise, it is set to 0. 0: SAI follows activity on S/T-interface per ETR 080. 1: Forces SAI = 1 on the U-interface.															
	UOA	U-Interface Only Activation. When the T9000 device is put in LT mode (DOCR[NT_LT] = 1), this bit becomes the UOA (U-only-activation) bit. This bit needs to be set to 1 to allow S/T activation at the NT.															
3	XPCY	Force U-Block Upstream Data Transparency. Asserts U-block XPCY bit, forcing U-block upstream 2B+D data transparency. 0: No effect on device operation. 1: Forces U-block data transparency.															
2	F_ACTUP	Force U-Interface Upstream ACT Bit. Normally, the state of the upstream ACT bit tracks the received INFO3 state on the S-interface. However, in cases where there is no TE attached, this bit allows manual control of the upstream ACT bit (via the ACTUP bit, below). 0: ACT bit follows INFO 3. 1: ACT bit follows ACTUP bit (see ACTUP below).															
	F_ACTDN	Force U-Interface Downstream ACT Bit. When the T9000 device is put in LT mode (DOCR[NT_LT] = 1), this bit controls the downstream ACT bit (via the ACTDN bit, described below). 0: Downstream ACT bit is zero. 1: Forces the value of ACTDN bit (described below) to be transferred downstream.															
1	ACTUP	ACT Upstream. Only valid when F_ACTUP bit is set (see F_ACTUP above). It controls the state of the upstream U-interface ACT bit. 0: Forces upstream ACT bit = 0. 1: Forces upstream ACT bit = 1.															
	ACTDN	ACT Downstream Bit. When the T9000 device is put in LT mode (DOCR[NT_LT] = 1), this bit controls the state of the downstream U-interface ACT bit. 0: Forces downstream ACT bit = 0. 1: Forces downstream ACT bit = 1.															

7 Transmission Superblock (continued)

7.6 DFAC Register Set (continued)

Table 24. UCR0: U-Interface Control Register #0 (0x07) (continued)

Bit #	Symbol	Name/Description
0	ISTP	<p>Initiate Start-Up. Setting this bit to 1 initiates a start-up sequence on the U-interface. After the activation attempt, this bit is internally cleared to 0, automatically.</p> <p>0: No effect on device operation. 1: Attempt one U activation.</p>

Table 25. UCR1: U-Interface Control Register #1 (0x08)

Reg	R/W	Bit 7	Bit 6	Bit 5	Bit 4	Bit 3	Bit 2	Bit 1	Bit 0
UCR1	R/W	R64T	R25T	R16T	R15T	ULBKMUX	ULLBK	USPMAG	USSP_E
RESET	Default	1	1	1	1	0	0	0	0

Bit #	Symbol	Name/Description
7	R64T	Transmit Reserved Bit. Controls upstream U-interface overhead bit R64.
6	R25T	Transmit Reserved Bit. Controls upstream U-interface overhead bit R25.
5—4	R[16:15]T	Transmit Reserved Bits. Controls upstream U-interface overhead bits R16 and R15.
3	ULBKMUX	<p>U-Interface Local Loopback MUX. Controls the point at which the U-interface local loopback takes place when the ULLBK bit (see below) is asserted.</p> <p>0: U local loopback occurs at the line interface (line must be disconnected during this operation). 1: U local loopback occurs at the interface between the digital and analog section of the U block. Line need not be disconnected during this operation.</p>
2	ULLBK	<p>U-Interface Local Loopback. Controls loopback of U-interface data stream at either the line interface or the digital-to-analog boundary in the U block, depending on the ULBKMUX bit (see above). ULLBK turns off the echo canceller and reconfigures the receive scrambler to match the transmit scrambler. If ULBKMUX = 0, the line should be disconnected prior to asserting ULLBK. This ensures that a sufficiently large echo is generated so that the device can detect the echo as received data and synchronize to it.</p> <p>0: No effect on device operation. 1: U-interface local loopback.</p>
1	USPMAG	<p>U Single Pulse Magnitude. Controls the magnitude of the pulse transmitted on the U-interface when the device is in the U send single pulse test mode (see USSP_E bit below).</p> <p>0: Transmit ± 3 pulses. 1: Transmit ± 1 pulses.</p>
0	USSP_E	<p>U Send Single Pulse Enable. Test mode that causes the U-interface to continuously transmit single 2B1Q pulses on the U-interface. The pulses occur at a rate of 1 pulse per 125 μs and alternate between positive and negative polarity. The magnitude of the pulses is controlled by USPMAG (see above).</p> <p>0: No effect on device operation. 1: Send single pulses on the U-interface.</p>

7 Transmission Superblock (continued)

7.6 DFAC Register Set (continued)

Table 26. USR0: U-Interface Status Register #0 (0x09)

Reg	R/W	Bit 7	Bit 6	Bit 5	Bit 4	Bit 3	Bit 2	Bit 1	Bit 0
USR0	R	AIB_n	FEBE_n	NEBE_n	UOA_n	DEA_n	OOF_n	XACT	ACTDN
RESET	Default	1	1	1	1	1	0	0	0

Bit #	Symbol	Name/Description
7	AIB_n	Alarm Indication Bit. Filtered (3x) version of downstream U-interface overhead bit AIB.
6	FEBE_n	Far-End Block Error. Indicates whether a CRC error was detected in the most recent U-interface received superframe at the far end. 0: CRC error in most recent far-end U superframe. 1: No CRC error detected at far end.
5	NEBE_n	Near-End Block Error. Indicates whether a CRC error was detected in the most recent U-interface received superframe. 0: CRC error in most recent received U superframe. 1: No CRC error detected in most recent received U superframe.
4	UOA_n	U-Interface Only Activation. Filtered (3x) version of downstream U-interface overhead bit UOA.
3	DEA_n	Deactivation Indication Bit. Filtered (2x) version of downstream U-interface overhead bit DEA.
2	OOF_n	Out of Frame. Indicates whether synchronization has been achieved on the U-interface. 0: U-interface out of frame. 1: U-interface is synchronized (SWs and ISWs are being properly detected).
1	XACT	U-Transceiver Active. 0: Transceiver is IDLE. No start-up requests are active. U block is in a low-power mode, and line driver is in a high-impedance power-saving mode. 1: Transceiver starting up or active.
0	ACTDN	Downstream Activation Bit. Filtered (3x) version of downstream U-interface overhead bit ACT.

Table 27. USR1: U-Interface Status Register #1 (0x0A)

Reg	R/W	Bit 7	Bit 6	Bit 5	Bit 4	Bit 3	Bit 2	Bit 1	Bit 0
USR1	R	—	R64R	R54R	R44R	R34R	R25R	R16R	R15R
RESET	Default	—	1	1	1	1	1	1	1

Bit #	Symbol	Name/Description
7	—	Reserved.
6—3	R[6:3]4R	Receive U Bits. Filtered (3x) version of downstream U-interface overhead bits R64, R54, R44, and R34.
2	R25R	Receive U Bit. Filtered (3x) version of downstream U-interface overhead bit R25.
1—0	R[16:15]R	Receive U Bits. Filtered (3x) version of downstream U-interface overhead bits R16 and R15.

7 Transmission Superblock (continued)

7.6 DFAC Register Set (continued)

Table 28. ECR0: EOC Control Register 0—Command and Address (0x0B)

Reg	R/W	Bit 7	Bit 6	Bit 5	Bit 4	Bit 3	Bit 2	Bit 1	Bit 0
ECR0	R/W	CCRC	LD	LB2	LB1	A1T	A2T	A3T	DMT
RESET	Default	0	0	0	0	0	0	0	1

Bit #	Symbol	Name/Description
7	CCRC	Corrupt Cyclic Redundancy Check. Used to corrupt the CRC information transmitted to the far end. This value is ORed with the CCRC control output generated by the EOC state machine (see ECCRC bit in register ESR0). 0: CRC is generated correctly. 1: CRC is corrupted.
6	LD	U-Interface D-Channel Loopback Control. Implements a D-channel loopback. This value is ORed with the 2B+D loopback control output generated by the EOC state machine (see ELBK2 bit in register ESR0). 0: No loopback. 1: D-channel transparent loopback from U-interface receiver to transmitter.
5	LB2	U-Interface B2-Channel Loopback Control. Implements a B2-channel loopback. This value is ORed with the 2B+D and B2 loopback control outputs generated by the EOC state machine (see ELBK2 and ELB2 bits in register ESR0). 0: No loopback. 1: B2-channel transparent loopback from U-interface receiver to transmitter.
4	LB1	U-Interface B1-Channel Loopback Control. Implements a B1-channel loopback. This value is ORed with the 2B+D and B1 loopback control outputs generated by the EOC state machine (see ELBK2 and ELB1 bits in register ESR0). 0: No loopback. 1: B1-channel transparent loopback from U-interface receiver to transmitter.
3—1	A[1:3]T	Transmit EOC Address. These bits are transmitted as the EOC channel address when in manual EOC mode. They have no effect when in AUTOEOC mode. A1T is the first bit transmitted. 000: NT address. 111: Broadcast address.
0	DMT	Transmit EOC Data or Message Indicator. This bit is transmitted as the EOC channel data/message indicator when in manual EOC mode. It has no effect when in AUTOEOC mode. I1T is the first bit transmitted. 0: Data. 1: Message.

7 Transmission Superblock (continued)

7.6 DFAC Register Set (continued)

Table 29. ECR1: EOC Control Register 1—Message (0x0C)

Reg	R/W	Bit 7	Bit 6	Bit 5	Bit 4	Bit 3	Bit 2	Bit 1	Bit 0
ECR1	R/W	I1T	I2T	I3T	I4T	I5T	I6T	I7T	I8T
RESET	Default	1	1	1	1	1	1	1	1

Bit #	Symbol	Name/Description
7—0	I[1:8]T	Transmit EOC Information. These bits are transmitted as the EOC channel message when in manual EOC mode. They have no effect when in AUTOEOC mode. I1T is the first bit transmitted.

Table 30. ESR0: EOC Status Register 0—Command and Address (0x0D)

Reg	R/W	Bit 7	Bit 6	Bit 5	Bit 4	Bit 3	Bit 2	Bit 1	Bit 0
ESR0	R	ECCRC	ELBK2	ELB2	ELB1	A1R	A2R	A3R	DMR
RESET	Default	0	0	0	0	1	1	1	1

Bit #	Symbol	Name/Description
7	ECCRC	EOCSM CCRC Bit. This bit contains the value of the CCRC output from the EOC state machine (EOCSM), and is valid in both auto and manual EOC modes. It provides a way to monitor the current output of the EOCSM.
6	ELBK2	EOCSM LBK2 Bit. This bit contains the value of the loopback-2 (2B+D) output from the EOCSM, and is valid in both auto and manual EOC modes. It provides a way to monitor the current output of the EOCSM.
5	ELB2	EOCSM LB2 Bit. This bit contains the value of the B2 output from the EOCSM, and is valid in both auto and manual EOC modes. It provides a way to monitor the current output of the EOCSM.
4	ELB1	EOCSM LB1 Bit. This bit contains the value of the B1 output from the EOCSM, and is valid in both auto and manual EOC modes. It provides a way to monitor the current output of the EOCSM.
3—1	A[1:3]R	Receive EOC Address. These bits contain the most recently received EOC address and are valid in both auto and manual EOC modes.
0	DMR	Receive EOC Data/Message Indicator. This bit contains the most recently received EOC data/message bit and is valid in both auto and manual EOC modes.

Table 31. ESR1: EOC Status Register 1—Message (0x0E)

Reg	R/W	Bit 7	Bit 6	Bit 5	Bit 4	Bit 3	Bit 2	Bit 1	Bit 0
ESR1	R	I1R	I2R	I3R	I4R	I5R	I6R	I7R	I8R
RESET	Default	1	1	1	1	1	1	1	1

Bit #	Symbol	Name/Description
7—0	I[1:8]R	Receive EOC Information. These bits contain the most recently received EOC channel message or data and are valid in both auto and manual EOC modes.

7 Transmission Superblock (continued)

7.6 DFAC Register Set (continued)

Table 32. SCR0: S-Interface Control Register #0 (0x0F)

Reg	R/W	Bit 7	Bit 6	Bit 5	Bit 4	Bit 3	Bit 2	Bit 1	Bit 0
SCR0	R/W	—	—	STOA	FACT	FT	MF_E	ST_E	SRESET
RESET	Default	0	0	0	0	0	0	1	0

Bit #	Symbol	Name/Description
7—6	—	Reserved. Program to 0.
5	STOA	<p>S/T-Only Activation. This bit allows the S/T-interface to perform a normal activation independent of the state of the U-interface. The S block will behave as if synchronization has been achieved on the U-interface and the downstream U-interface ACT bit has been received. It will reach its full activation state (G3, transmitting INFO4) only if a TE is attached. Note the difference in function between this bit and FACT, below.</p> <p>0: Normal operation. 1: Allows S/T activation independent of the U-interface state.</p> <p>When STOA is cleared to zero, the SRESET bit must be asserted. If a U-interface activation occurs while STOA is active, STOA must be deasserted before any further U-activation attempts will be recognized by the device.</p>
4	FACT	<p>S/T Force Activation. This bit forces the S/T-interface to proceed directly to its full activation state (G3, transmitting INFO4) regardless of whether a TE is attached or what the state of the U-interface is. This may be useful for test purposes. Note the difference in function between this bit and STOA, above. In order for this bit to have any effect, the S/T-interface must be enabled.</p> <p>0: Normal operation. 1: Forces S block to transmit INFO4.</p> <p>If a U-interface activation occurs while FACT is active, FACT must be deasserted before any further U-activation attempts will be recognized by the device.</p>
3	FT	<p>Fixed/Adaptive Timing Selection. Determines whether the S/T-interface receiver uses fixed or adaptive timing.</p> <p>0: Adaptive timing. When this bit is set to 0, incoming data at the S/T-interface is sampled at a point defined by an adaptive timing algorithm. This mode is used in point-to-point configuration (only 1 TE) or a multi-TE configuration on an extended passive bus, where the round-trip delay can vary from 10 μs to 42 μs, but the differential delay between various TEs is less than 2 μs.</p> <p>1: Fixed timing. When this bit is set to 1, incoming data at the S/T-interface is sampled with a fixed delay relative to the S/T transmitter clock. This mode is used in a multi-TE configuration with a short passive bus, where the round-trip delay variations are 10 μs to 14 μs.</p>
2	MF_E	<p>S/T-Interface Multiframe Enable. Enables the multiframe controller and allows the microcontroller to access the S and Q channels. When disabled, multiframe is not implemented (the device transmits all 0s in the FA and M bit positions and all 1s in the S bit positions to the TE). Also register bits MFR0(3:0) are forced to 1 and MFR1(3:0) are forced to 0 when multiframe is disabled.</p> <p>0: Disable multiframe controller. 1: Enable multiframe controller.</p>
1	ST_E	<p>S/T-Interface Enable. This signal enables the S/T-interface.</p> <p>0: S/T-interface is powered down and disabled. 1: S/T-interface is enabled and can respond to activation attempts.</p>
0	SRESET	<p>S/T-Interface Reset. Writing a one to this bit causes a reset of the S/T-interface, initializing the interface in the same manner as the external RESET pin.</p> <p>0: Normal operation. 1: Reset S/T-interface (nonlatching—this bit clears itself and will always be read back as 0).</p>

7 Transmission Superblock (continued)

7.6 DFAC Register Set (continued)

Table 33. SCR1: S-Interface Control Register #1 (0x10)

Reg	R/W	Bit 7	Bit 6	Bit 5	Bit 4	Bit 3	Bit 2	Bit 1	Bit 0
SCR1	R/W	—	—	—	RLB_D	RLB_B2	RLB_B1	TE_DA	—
RESET	Default	0	0	0	0	0	0	0	0

Bit #	Symbol	Name/Description
7—5	—	Reserved. Program to 0.
4	RLB_D	S/T Remote Loopback—D Channel. 0: Normal operation. 1: D-channel data received at the S/T-interface is transmitted back to the TE.
3	RLB_B2	S/T Remote Loopback—B2 Channel. 0: Normal operation. 1: B2-channel data received at the S/T-interface is transmitted back to the TE.
2	RLB_B1	S/T Remote Loopback—B1 Channel. 0: Normal operation. 1: B1-channel data received at the S/T-interface is transmitted back to the TE.
1	TE_DA	Timer Expired/Deactivate. This signal is used to inform the S-block activation state machine that an external timer (normally activation timer T1) has expired or that deactivation is requested. It will force deactivation of the S-interface. 0: Normal operation. 1: Force deactivation of S/T-interface.
0	—	Reserved. Program to 0.

7 Transmission Superblock (continued)

7.6 DFAC Register Set (continued)

Table 34. SSR: S-Interface Status Register (0x11)

Reg	R/W	Bit 7	Bit 6	Bit 5	Bit 4	Bit 3	Bit 2	Bit 1	Bit 0
SSR	R	FSERR	—	—	RXINFO3	RXINFO1	ASI2	ASI1	ASI0
RESET	Default	0	—	—	0	0	0	0	0

Bit #	Symbol	Name/Description
7	FSERR	S/T-Block Receiver Frame Synchronization Error. This bit reflects the current state of the FSERR bit from the S/T-block. FSERR indicates that a framing error has occurred on the S/T-interface. Any type of frame error (including a transition from INFO2 or INFO4 to INFO0) immediately sets FSERR = 1. FSERR is reset to zero upon completion of an error-free frame. Note that bit SIR[FSERRL] is a latched version of this signal.
6—5	—	Reserved.
4	RXINFO3	Receiving INFO3. This bit tracks the reception of INFO3 on the S/T-interface. 0: INFO3 not detected. 1: INFO3 present.
3	RXINFO1	Receiving INFO1. This bit tracks the reception of INFO1 on the S/T-interface. 0: INFO1 not detected. 1: INFO1 present.
2—0	ASI[2:0]	S-Block G State. These 3 bits reflect the current state of the S/T-block activation state machine. 000: S/T-interface disabled. Sending INFO0. 001: (I.430 G1 State) deactivated. NT and TE are deactivated; both are sending INFO0. 010: (I.430 G2 State) pending activation. NT is transmitting INFO2 to initiate activation (ACT bit = 1) and is receiving INFO0. 011: (I.430 G3 State) activated. NT and TE are fully activated; i.e., NT transmitting INFO4 and receiving INFO3. 100: (I.430 G4 State) pending deactivation. S/T-interface is sending INFO0. 101: S/T-interface is receiving INFO1 and waiting for synchronization on the U-interface before transmitting INFO2 (i.e., the S/T block has exited state G1 but not yet entered state G2). This is not an I.430-defined state, but is required for NT1 implementation. 110: S/T-interface is receiving INFO3 and waiting for activation indication (U-interface downstream ACT = 1) on the U-interface before transmitting INFO4 (i.e., the S/T block has exited state G2 but not yet entered state G3). This is not an I.430 state, but is required for NT1 implementation. 111: Not used.

7 Transmission Superblock (continued)

7.6 DFAC Register Set (continued)

Table 35. MFR0: Multiframe Register, Q-Channel Data (0x12)

Reg	R/W	Bit 7	Bit 6	Bit 5	Bit 4	Bit 3	Bit 2	Bit 1	Bit 0
MFR0	R	—	—	—	—	QD1	QD2	QD3	QD4
RESET	Default	—	—	—	—	1	1	1	1

Bit #	Symbol	Name/Description
7—4	—	Reserved.
3—0	QD[1:4]	Q-Channel Data. When multiframing is enabled (SCR0[MF_E] = 1), these bits contain the Q-channel bits of the most recent complete multiframe. When multiframing is disabled, these bits are set to 1. The interrupt bit SIRQ[QSC] can be used to notify the microcontroller of the reception of a new Q-channel message. In order to avoid having the existing Q-channel data overwritten by a new Q-channel message, the read operation must be complete within 20 S/T-interface frames of when QSC becomes asserted, that is 5 ms. The order of transmission is Q1 first to Q4 last.

Table 36. MFR1: Multiframe Register, S-Subchannel Data (0x13)

Reg	R/W	Bit 7	Bit 6	Bit 5	Bit 4	Bit 3	Bit 2	Bit 1	Bit 0
MFR1	W	—	—	—	—	SSD1	SSD2	SSD3	SSD4
RESET	Default	0	0	0	0	0	0	0	0

Bit #	Symbol	Name/Description
7—4	—	Reserved. Program to 0.
3—0	SSD[1:4]	S-Subchannel Data, Subchannels 1 to 5. When multiframing is enabled (SCR0[MF_E] = 1), these bits can be written to transmit data onto the five S subchannels SC1—SC5. When multiframing is disabled, these bits are set to 0. The interrupt bit SIR[SSRDY] can be used to notify the microcontroller that this register is ready to accept a new set of S-subchannel data. Up to 5 nibbles may be written to this register upon reception of the SSRDY interrupt. Each successive nibble written will be transmitted on the next available subchannel, and if less than 5 nibbles are written, the remaining subchannels will transmit all 1s. For example, if two nibbles are written, the first nibble will be transmitted on subchannel SC1, the second nibble will be transmitted on subchannel SC2, and all 1s will be transmitted on the remaining subchannels, SC3—SC5. The write operation must be complete within five S/T-interface frames of when SSRDY becomes asserted (1.25 ms). The order of transmission is SSD1 first to SSD4 last.

7 Transmission Superblock (continued)

7.6 DFAC Register Set (continued)

Table 37. UIR: U-Interface Interrupt Register (0x14)

Reg	R/W	Bit 7	Bit 6	Bit 5	Bit 4	Bit 3	Bit 2	Bit 1	Bit 0
UIR	R	RSF	RHSF	BERR	ACTSC	OUSC	EOC3SC	EOCSC	ECNFY
RESET	Default	0	0	0	0	0	0	0	0

Note: All bits in this register are set to 1 upon occurrence of the corresponding interrupt condition, and are cleared to 0 when the register is read.

Bit #	Symbol	Name/Description
7	RSF	Receive Superframe. This interrupt occurs at the beginning of each downstream U-interface superframe, and signifies that a new group of U-overhead bits is available.
6	RHSF	Receive Half Superframe. This interrupt occurs just after processing the downstream EOC data/message on the U-interface, i.e., every half superframe (6 ms). This can be useful in the case of any nonstandard use of the EOC channel where it is required to know when new data has arrived. If a response to the incoming EOC message is required (for example, in the case of manual EOC processing), the microcontroller has approximately 1.5 ms to write the response data to registers ECR0 and ECR1 before it is transmitted.
5	BERR	Block Error. This interrupt occurs on U-superframe boundaries whenever a NEBE or FEBE error has been detected in the previous superframe. The most recent NEBE and FEBE values are available in register USR0.
4	ACTSC	Downstream Activation State Change. This interrupt occurs whenever any of the following bits (found in register USR0) change state: ACTDN, XACT, OOF_n, DEA_n, UOA_n, AIB_n.
3	OUSC	Other U-Interface State Change. This interrupt occurs whenever any of the following bits (found in register USR1) change state: R15R, R16R, R25R, R34R, R44R, R54R, R64R.
2	EOC3SC	New Trinal-Checked EOC Message Received. This interrupt occurs when a trinal-checked EOC message has been received that is different than the most recent trinal-checked EOC message.
1	EOCSC	New EOC Message Received. This interrupt occurs whenever the current EOC message is different from the previous EOC message (no trinal-checking is performed).
0	ECNFY	EOC Corrupt CRC Notify State Change. This is a status bit only. It will not cause an interrupt (so it has no corresponding enable bit in register UIE); it is for polling only. It is only valid when in AUTOEOC mode. It provides a way to monitor the current output of the EOCSM, and is logically part of the group of bits ECCRC, ELBK2, ELB2, ELB1 found in ESR0.

7 Transmission Superblock (continued)

7.6 DFAC Register Set (continued)

Table 38. UIE: U-Interface Interrupt Enable (0x15)

This register contains enable bits for the interrupts in register UIR.

Reg	R/W	Bit 7	Bit 6	Bit 5	Bit 4	Bit 3	Bit 2	Bit 1	Bit 0
UIE	R/W	RSFE	RHSFE	BERRE	ACTSCE	OUSCE	EOC3SCE	EOCSCE	—
RESET	Default	0	0	0	0	0	0	0	—

Bit #	Symbol	Name/Description
7	RSFE	RSF Interrupt Enable. 0: Interrupt disabled. 1: Interrupt enabled.
6	RHSFE	RHSF Interrupt Enable. 0: Interrupt disabled. 1: Interrupt enabled.
5	BERRE	BERR Interrupt Enable. 0: Interrupt disabled. 1: Interrupt enabled.
4	ACTSCE	ACTSC Interrupt Enable. 0: Interrupt disabled. 1: Interrupt enabled.
3	OUSCE	OUSC Interrupt Enable. 0: Interrupt disabled. 1: Interrupt enabled.
2	EOC3SCE	EOC3SC Interrupt Enable. 0: Interrupt disabled. 1: Interrupt enabled.
1	EOCSCE	EOCSC Interrupt Enable. 0: Interrupt disabled. 1: Interrupt enabled.
0	—	—

7 Transmission Superblock (continued)

7.6 DFAC Register Set (continued)

Table 39. SIR: S-Interface Interrupt Register (0x16)

Reg	R/W	Bit 7	Bit 6	Bit 5	Bit 4	Bit 3	Bit 2	Bit 1	Bit 0
SIR	R	—	—	—	—	SSC	FSERRL	QSC	SSRDY
RESET	Default	—	—	—	—	0	0	0	0

Note: All defined bits in this register are set to 1 upon occurrence of the corresponding interrupt condition, and are cleared to 0 when the register is read.

Bit #	Symbol	Name/Description
7—4	—	Reserved.
3	SSC	S-Interface Activation State Change. This interrupt occurs whenever any one of the RXINFO3, RXINFO1, and ASI[2:0] bits in register SSR changes state.
2	FSERRL	S-Interface Receiver Frame Synchronization Error, Latched. This interrupt occurs on the rising edge of the FSERR signal from the S block (see bit SSR[FSERR]), and is reset when read. Note that this interrupt will occur only when FSERR transitions from 0 to 1. If the FSERR condition persists after reading this bit, it will not cause this bit to be set again until FSERR goes away, and then transitions to 1 again. To poll the current state of FSERR, bit SSR[FSERR] can be used.
1	QSC	S-Interface Q Bit Change. This interrupt occurs to signal that a complete Q-channel nibble has been received and is available in register MFR0.
0	SSRDY	S-Interface Ready to Accept New S-Channel Nibble. This interrupt occurs to signal that the current S-subchannel nibbles have been transmitted and a new set may be written to register MFR1.

Table 40. SIE: S-Interface Interrupt Enable Register (0x17)

This register contains enable bits for the interrupts in register SIR.

Reg	R/W	Bit 7	Bit 6	Bit 5	Bit 4	Bit 3	Bit 2	Bit 1	Bit 0
SIE	R/W	—	—	—	—	SSCE	FSERRLE	QSCE	SSRDYE
RESET	Default	0	0	0	0	0	0	0	0

Bit #	Symbol	Name/Description
7—4	—	Reserved. Program to 0.
3	SSCE	SSC Interrupt Enable. 0: Interrupt disabled. 1: Interrupt enabled.
2	FSERRLE	FSERRL Interrupt Enable. 0: Interrupt disabled. 1: Interrupt enabled.
1	QSCE	QSC Interrupt Enable. 0: Interrupt disabled. 1: Interrupt enabled.
0	SSRDYE	SSRDY Interrupt Enable. 0: Interrupt disabled. 1: Interrupt enabled.

8 Device Operation Control

8.1 Device Operation Register

Table 41. DOCR: Device Operation Control Register (0x50)

Reg	R/W	Bit 7	Bit 6	Bit 5	Bit 4	Bit 3	Bit 2	Bit 1	Bit 0
DOCR	R/W	FORCE_SAI_STD	BS_E	—	—	NT_LT	—	—	—
RESET	Default	0	0	0	0	0	0	0	0

Bit #	Symbol	Name/Description
7	FORCE_SAI_STD	FORCE SAI Bit to Follow ETSI Standard. Controls the value of the upstream SAI bit, as may be required when conformance testing with a <i>Siemens</i> * K1404 U-interface tester. 0: When this bit is set to 0, the SAI bit upstream remains high during the period from RXINFO1 going low to RXINFO3 going high, so the <i>Siemens</i> K1404 will not initiate U-only activation when TE-initiated activation is being tested. 1: When this bit is set to 1, the SAI bit remains low conforming to the ETSI ETR 080 standard.
6	BS_E	Backswing Suppression Enable. This bit enables the backswing suppression feature on the S/T-interface. It is recommended that this bit be programmed to 0. 0: Backswing suppression enabled. 1: Backswing suppression not used.
5—4	—	Reserved. Program to 0.
3	NT_LT	NT or LT Operation of the NTN Device. This bit selects the NT or LT operation of the device. This bit defaults to 0, selecting NT mode. When programmed to 1, the NTN device is in LT mode. When set to LT mode, GPIO2.6 is the input (regardless of the GPDIR2 value) for the 8 kHz MTC signal.
2—0	—	Reserved. Program to 0.

* *Siemens* is a trademark of Siemens Aktiengesellschaft.

Table 42. B1UP: B1-Channel Upstream Data from GCI to U-Interface (0x51)

Reg	R/W	Bit 7	Bit 6	Bit 5	Bit 4	Bit 3	Bit 2	Bit 1	Bit 0
B1UP	R/W	B1UP7	B1UP6	B1UP5	B1UP4	B1UP3	B1UP2	B1UP1	B1UP0
RESET	Default	—	—	—	—	—	—	—	—

Bit #	Symbol	Name/Description
7—0	B1UP[7:0]	B1-Channel Upstream Data. When DFR[U_FORCE_B1UP] = 1, DFR[B1_SEL] = 1, and ECR0[LB1] = 0, the microcontroller can write into this register the content that the user wants to be transferred on the upstream B1 channel from GCI to the U-interface.

8 Device Operation Control (continued)

8.1 Device Operation Register (continued)

Table 43. B2UP: B2-Channel Upstream Data from GCI to U-Interface (0x52)

Reg	R/W	Bit 7	Bit 6	Bit 5	Bit 4	Bit 3	Bit 2	Bit 1	Bit 0
B2UP	R/W	B2UP7	B2UP6	B2UP5	B2UP4	B2UP3	B2UP2	B2UP1	B2UP0
RESET	Default	—	—	—	—	—	—	—	—

Bit #	Symbol	Name/Description
7—0	B2UP[7:0]	B2-Channel Upstream Data. When DFR[U_FORCE_B2UP] = 1, DFR[B2_SEL] = 1, and ECR0[LB2] = 0, the microcontroller can write into this register the content that the user wants to be transferred on the upstream B2 channel from GCI to the U-interface.

Table 44. B1DN: B1-Channel Downstream Data from U-Interface to GCI (0x53)

Reg	R/W	Bit 7	Bit 6	Bit 5	Bit 4	Bit 3	Bit 2	Bit 1	Bit 0
B1DN	R/W	B1DN7	B1DN6	B1DN5	B1DN4	B1DN3	B1DN2	B1DN1	B1DN0
RESET	Default	—	—	—	—	—	—	—	—

Bit #	Symbol	Name/Description
7—0	B1DN[7:0]	B1-Channel Downstream Data. When GCOF1[U_FORCE_B1DN] = 1, DFR[B1_SEL] = 1, and ECR0[LB1] = 0, the microcontroller can write into this register the content that the user wants to be transferred on the downstream B1 channel from GCI to the U-interface.

Table 45. B2DN: B2-Channel Downstream Data from U-Interface to GCI (0x54)

Reg	R/W	Bit 7	Bit 6	Bit 5	Bit 4	Bit 3	Bit 2	Bit 1	Bit 0
B2DN	R/W	B2DN7	B2DN6	B2DN5	B2DN4	B2DN3	B2DN2	B2DN1	B2DN0
RESET	Default	—	—	—	—	—	—	—	—

Bit #	Symbol	Name/Description
7—0	B2DN[7:0]	B2-Channel Downstream Data. When GCOF2[U_FORCE_B2DN] = 1, DFR[B2_SEL] = 1, and ECR0[LB2] = 0, the microcontroller can write into this register the content that the user wants to be transferred on the downstream B2 channel from GCI to the U-interface.

8 Device Operation Control (continued)

8.1 Device Operation Register (continued)

Table 46. Reserved 1: Reserved Register for Internal Use (0x55)

Reg	R/W	Bit 7	Bit 6	Bit 5	Bit 4	Bit 3	Bit 2	Bit 1	Bit 0
Reserved1	R	—	—	—	—	—	—	—	—
RESET	Default	—	—	—	—	—	—	—	—

Bit #	Symbol	Name/Description
7—0	—	Reserved Register for Internal Use.

Table 47. Reserved 2: Reserved Register for Internal Use (0x56)

Reg	R/W	Bit 7	Bit 6	Bit 5	Bit 4	Bit 3	Bit 2	Bit 1	Bit 0
Reserved2	R/W	—	—	U_FDEACT	U_R54T	MLSE_POWER_DN	—	—	—
RESET	Default	—	—	0	1	0	—	—	—

Bit #	Symbol	Name/Description
7—6	—	Reserved for Internal Use.
5	U_FDEACT	U-Interface Force Deactivation. When the NTN device is in LT mode [DOCR(NT_LT=1)], setting this bit to 1 forces the NTN device to send three or four U superframes of dea = 0 and then switch the transceiver off. When the NTN device is in NT mode, this bit has no effect.
4	U_R54T	Transmit Reserved Bit. When the NTN device is in LT mode [DOCR(NT_LT=1)], this bit is sent as the R54 reserved bit. When the NTN device is in NT mode, this bit has no effect.
3	MLSE_POWER_DN	Maximum Likelihood Sequence Estimation, Powerdown. This bit, when set to 1, powers down the MLSE algorithm in the T9000 device, thereby providing a power savings of approximately 15 mW, but the T9000 device does not pass the ETSI performance test on loop3 (and loop3 reversed) with +2.5 dB noise level, when this bit is set to 1. Thus, this bit needs to be set to 0 to pass the ETSI performance test on loop3 (and loop3 reversed) with +2.5 dB noise level. Note: When setting this bit to 1, care must be taken to not change the other bit values in this register. The user must perform a read, modify, and write operation when changing this bit value, to make sure other bit values are unchanged.
2—0	—	Reserved for Internal Use.

Table 48. Reserved 3: Reserved Register for Internal Use (0x57)

Reg	R/W	Bit 7	Bit 6	Bit 5	Bit 4	Bit 3	Bit 2	Bit 1	Bit 0
Reserved3	R	—	—	—	—	—	—	—	—
RESET	Default	—	—	—	—	—	—	—	—

Bit #	Symbol	Name/Description
7—0	—	Reserved Register for Internal Use.

8 Device Operation Control (continued)

8.1 Device Operation Register (continued)

Table 49. Reserved 4: Reserved Register for Internal Use (0x58)

Reg	R/W	Bit 7	Bit 6	Bit 5	Bit 4	Bit 3	Bit 2	Bit 1	Bit 0
Reserved4	R	—	—	—	—	—	—	—	—
RESET	Default	—	—	—	—	—	—	—	—

Bit #	Symbol	Name/Description
7—0	—	Reserved for Internal Use.

Table 50. Reserved 5: Reserved Register for Internal Use (0x59)

Reg	R/W	Bit 7	Bit 6	Bit 5	Bit 4	Bit 3	Bit 2	Bit 1	Bit 0
Reserved5	R	—	—	—	—	—	—	—	—
RESET	Default	—	—	—	—	—	—	—	—

Bit #	Symbol	Name/Description
7—0	—	Reserved for Internal Use.

Table 51. Reserved 6: Reserved Register for Internal Use (0x5A)

Reg	R/W	Bit 7	Bit 6	Bit 5	Bit 4	Bit 3	Bit 2	Bit 1	Bit 0
Reserved6	R	—	—	—	—	—	—	—	—
RESET	Default	—	—	—	—	—	—	—	—

Bit #	Symbol	Name/Description
7—0	—	Reserved for Internal Use.

Table 52. Reserved 7: Reserved Register for Internal Use (0x5B)

Reg	R/W	Bit 7	Bit 6	Bit 5	Bit 4	Bit 3	Bit 2	Bit 1	Bit 0
Reserved7	R	—	—	—	—	—	—	—	—
RESET	Default	—	—	—	—	—	—	—	—

Bit #	Symbol	Name/Description
7—0	—	Reserved for Internal Use.

8 Device Operation Control (continued)

8.1 Device Operation Register (continued)

Table 53. Reserved 8: Reserved Register for Internal Use (0x5C)

Reg	R/W	Bit 7	Bit 6	Bit 5	Bit 4	Bit 3	Bit 2	Bit 1	Bit 0
Reserved8	R	—	—	—	—	—	—	—	—
RESET	Default	—	—	—	—	—	—	—	—

Bit #	Symbol	Name/Description
7—0	—	Reserved for Internal Use.

Table 54. Reserved 9: Reserved Register for Internal Use (0x5D)

Reg	R/W	Bit 7	Bit 6	Bit 5	Bit 4	Bit 3	Bit 2	Bit 1	Bit 0
Reserved9	R	—	—	—	—	—	—	—	—
RESET	Default	—	—	—	—	—	—	—	—

Bit #	Symbol	Name/Description
7—0	—	Reserved for Internal Use.

9 HDLC with FIFO Module

The HDLC (high-level data link) module supports standard HDLC framing and deframing functionality on the D channel of the NTN. Two 64 x 9 register files are used to implement transmitter and receiver FIFOs, and address recognition is performed on the incoming frames.

Data/parameter exchange between the microcontroller and the HDLC module is done by reading/writing a set of registers. Interrupts are used to request microcontroller intervention.

Data to be framed and transmitted is written into the FIFO by the microcontroller via registers HTX and HTXL. All bytes of a packet, except the last one, are written to HTX. The last byte is written to HTXL. HTX and HTXL occupy the same physical space (the transmit FIFO).

The microcontroller reads data from the receive FIFO via register HRX.

9.1 HDLC Transmitter

The HDLC transmitter automatically frames user data packets (UDPs) by inserting starting and closing flags, inserting (if requested) the frame check sequence (calculated according to the ITU-16 polynomial cyclic redundancy check [CRC]) and performing zero-bit insertion on the user data and frame check sequence (FCS).

Packets to be framed are transferred by the microcontroller into the transmitter FIFO by writing to the HTX and HTXL registers. Multiple HDLC packets can be written into the transmitter FIFO. For all bytes of a packet, except the last one, the microcontroller should write the data byte into the HTX register. The last byte of a packet is written into the HTXL register. Figure 9 shows the transmitter FIFO contents in the case where the microcontroller has written two complete 9-byte packets into the transmitter FIFO and partially written a third packet. For packets #1 and #2, bytes 0 to 7 are written to register HTX and byte 8 is written to register HTXL. The HDLC transmitter FIFO manager indicates the number of free bytes currently in the transmitter FIFO via read-only register HTSA. At the snapshot in time represented by the figure, the HDLC transmitter is ready to accept byte P3-B2. Also, the microcontroller can write up to 48 bytes before the FIFO is filled, because the first four bytes of the first packet have been transmitted.

9.1.1 HDLC Transmitter Initialization

On powerup, the HDLC transmitter is initialized automatically. After powerup, whenever there is any change to the HTCF[MANCRC] or HTCF[TXMODE] configuration bits, the bit HTCF[TX_INIT] needs to be set to 1 to reinitialize the HDLC transmitter. Once the initialization is completed, the HTCF[TX_INIT] bit returns to 0.

During initialization, register bit HTCF[MANCRC] is sampled. If it is zero (the default), the FCS will be calculated automatically, according to the ITU 16 polynomial cyclic redundancy check (CRC-16) and inserted at the end of the user data. If HTCF[MANCRC] = 1, no FCS automatic insertion is done; it is the responsibility of the user software to perform the FCS insertion if desired. This feature may be useful in cases where it is necessary to use an FCS other than that in the ITU standard.

Users may abort the current frame transmission by asserting register bit HTCF[ABRT_RQ]. When this occurs, the transmitter FIFO manager will flush the contents of the transmitter FIFO. This bit automatically returns to 0 once the abort sequence has been initiated.

Register bit HTCF[IDL] determines the idle pattern to be sent by the HDLC transmitter when there are no packets to be framed. If set to 0, flags (01111110) will be inserted between the closing flag of a frame and the opening flag of the next frame. If set to 1, idles (11111111) will be inserted.

In certain applications where buffer overloading at the far-end receiver can occur, there may be a requirement to add a minimum number of extra interframe fill bytes at the end of each frame. HTCF[FCNT(2:0)] determines the number of fill bytes to be sent at the end of a packet. For FCNT(2:0) = n (where n > 0), n - 1 interframe flags are padded after the closing flag of one frame and the opening flag of the next frame. For the case of n = 0, the closing flag of one frame acts as the opening flag of the next frame (i.e., back-to-back frames are supported).

The HTTH[TFAE] register bits determine the threshold that the queue manager uses to control assertion of the HIR[TTHR] interrupt register bit. This bit is asserted when, as a consequence of a read of the transmitter FIFO by the HDLC framer, the available space of the FIFO exceeds the number in the HTTH[TFAE].

Interrupt register bit HIR[TFC] is asserted at the end of the closing flag of a transmitted frame.

9 HDLC with FIFO Module (continued)

9.1 HDLC Transmitter (continued)

9.1.1 HDLC Transmitter Initialization (continued)

Interrupt register bit HIR[TUNDR] is asserted to indicate that an underrun error has occurred during the transmission of a frame. An underrun error occurs when the transmitter has completed the transmission of a user byte that is not the last of a packet and detects that the transmitter FIFO is empty. In this case, the frame is completed by inserting the abort pattern, 01111111.

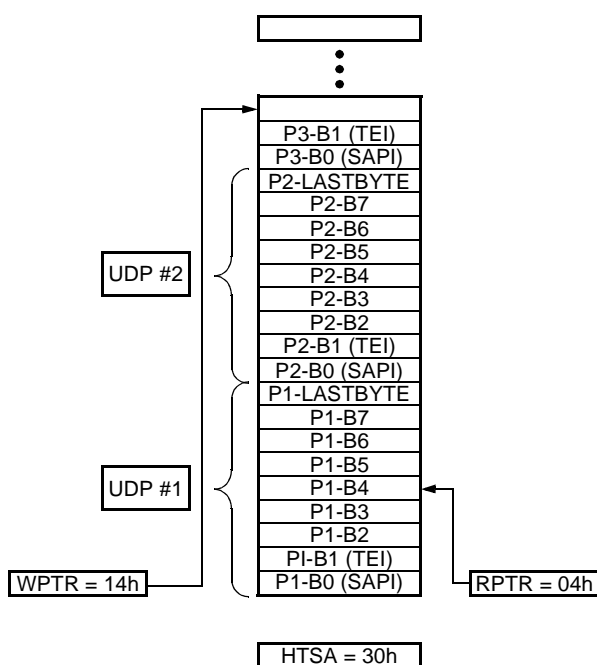

Note: RPTR = read pointer, WPTR = write pointer.

Figure 9. HDLC Transmitter FIFO

9.2 HDLC Transmitter D-Channel Access

The HDLC transmitter accesses the upstream D channel using a priority mechanism (implemented via an arbitration circuit) equivalent to that specified in the ITU-I.430 standard for TEs on the S/T bus. The arbiter automatically grants control to the HDLC module if one of these conditions occurs:

- S/T-interface is not fully active (no INFO 3 is being received on the S/T-interface).
- SCR0[FACT] register bit is set to 1.
- DFR[FORCE_D] register bit is set to 1.

When none of the above conditions are true and INFO 3 is being received on the S/T-interface, the priority circuit determines when the HDLC module is granted access to the upstream D channel. The arbiter will grant access to the HDLC module when 8 or 9 (for priority class 1) or 10 or 11 (for priority class 2) consecutive ones are received on the upstream S/T D channel. The priority class is controlled via register bit HTTH[PCLASS]. Within a priority class, the priority level (i.e., 8/9 or 10/11) is automatically managed. Once the packet has been transmitted, the HDLC module releases control to the internal arbiter for a new arbitration.

When the S/T-interface is active, the microcontroller may force access to the upstream D channel to be granted to the HDLC module by asserting register bit DFR[FORCE_D]. Normally, the upstream (received) D-channel bit (D bit) from the TEs is echoed downstream in the E-bit position. When FORCE_D is asserted, the inverted version of the D bit is echoed. This has the effect of guaranteeing that all active TEs will cease transmission (due to a collision error) and no new transmissions will be initiated. In this way, upstream access to the D channel is granted exclusively to the local HDLC controller.

When the S/T-interface is disabled (SCR0[ST_E] = 0) or in force activate mode (SCR0[FACT] = 1), the HDLC transmitter will be granted immediate access to the upstream D channel. If the HDLC module is granted access to the D channel and does not have any data to transmit, it will transmit the idle pattern determined by HTCF[IDL]. For operation with TEs running the LAPD protocol, HTCF[IDL] should be set to 1.

5-7099F

9 HDLC with FIFO Module (continued)

9.3 HDLC Receiver

Downstream D channel is always transferred to the HDLC receiver. The HDLC receiver removes flags, does zero bit deletion, and calculates the FCS for the downstream D-channel information. Deframed data is converted from serial to parallel (byte delimited) and passed to the microcontroller through the receiver FIFO HRX register.

9.3.1 HDLC Receiver Initialization

On powerup, the HDLC receiver is initialized automatically. After powerup, whenever there is any change to the HRCF[DROPCRC], HRCF[RXMODE], HRCF[BAE], or HSM0[BAP(7:0)] configuration bits, the bit HRCF[RX_INIT] must be set to 1 to reinitialize the HDLC receiver. Once the initialization is completed, the HRCF[RX_INIT] bit automatically returns to 0.

During initialization, register bit HRCF[DROPCRC] is sampled. If it is one (the default), the FCS will be dropped (not stored in the receiver FIFO). If HRCF[DROPCRC] = 0, the complete deframed packet, including its FCS, will be stored in the receiver FIFO.

If the device is programmed for address matching, then prior to storing a packet in the receiver FIFO, its address is checked against a set of patterns (see Section 9.4, Address Recognition). Only packets with an address field matching one of the programmed address values are transferred to the receiver FIFO, all others are rejected. At the end of a frame, a status byte is transferred to the HDLC receiver FIFO that provides information about the following events: frame-overflow, frame-complete, frame-error, and frame-abort.

Figure 10 shows the structure of the status byte. Each bit is set to one when the corresponding condition is active.

Bit 7 (OVR). The overrun bit indicates that the frame has been closed by a receive FIFO overrun condition (see section 9.3.1.1 Overrun Condition).

Bit 6 (EOF). The end of frame bit indicates that the packet has been properly terminated with a closing flag.

Bit 5 (FERR). The FCS error bit indicates that the results of comparing the incoming FCS with internally calculated FCS on the received data (according to the ITU CRC-16 polynomial) did not match.

Bit 4 (FABRT). The frame abort bit indicates that the frame has been closed with an abort pattern (01111111).

Bits 2—0 (CBIT). The check error bit provides an extra error check. In most HDLC based protocols, the packet length is an exact multiple number of bytes. When this is the case, CBIT = 111. Otherwise, CBIT ≠ 111.

The above definitions for the status bits imply that correctly received frames will have 47h as the status byte. Bit 3 is reserved and is set to 0.

7	6	5	4	3	2:0
OVR	EOF	FERR	FABRT	—	CBIT

Figure 10. HDLC Receiver Status Word

Multiple packets may be stored in the receiver FIFO at a given time. The HRDA[NBNSW] register bits indicate the number of bytes until the next status word in the FIFO. If there are no status words in the FIFO, it indicates the number of bytes of an unfinished packet currently stored into the FIFO.

Packets less than 2 bytes in length (4 bytes if HRCF[DROPCRC] = 1) are automatically rejected.

9 HDLC with FIFO Module (continued)

9.3 HDLC Receiver (continued)

9.3.1 HDLC Receiver Initialization (continued)

Figure 11 represents a sequence of snapshots in time of the receiver FIFO.

In Figure 11 (a), the FIFO is empty, so HRDA = 00h.

In Figure 11 (b), the first five bytes of a packet have been loaded into the FIFO; register HRDA indicates that there is no status byte in the FIFO (HRDA[SWRF] = 0) and also indicates the number of bytes currently in the FIFO (HRDA[NBNSW] = 05h).

In Figure 11 (c), a complete packet has been loaded into the FIFO and part of a second packet has been loaded. In this case, HRDA[SWRF] = 1, which indicates that there is a status byte in the receiver FIFO. HRDA[NBNSW] = 09h indicates that the status byte is the ninth byte in the FIFO.

In Figure 11 (d), the second packet has been completely loaded into the receiver FIFO, part of a third packet has been received, and some bytes of the first packet have been read by the microcontroller.

Figure 11 (e) represents the case in which the microcontroller has read all bytes of the first packet except its status byte. A new read of the FIFO (HRX register) will cause the HRDA register to point to the status byte of the second packet, as shown in Figure 11 (f).

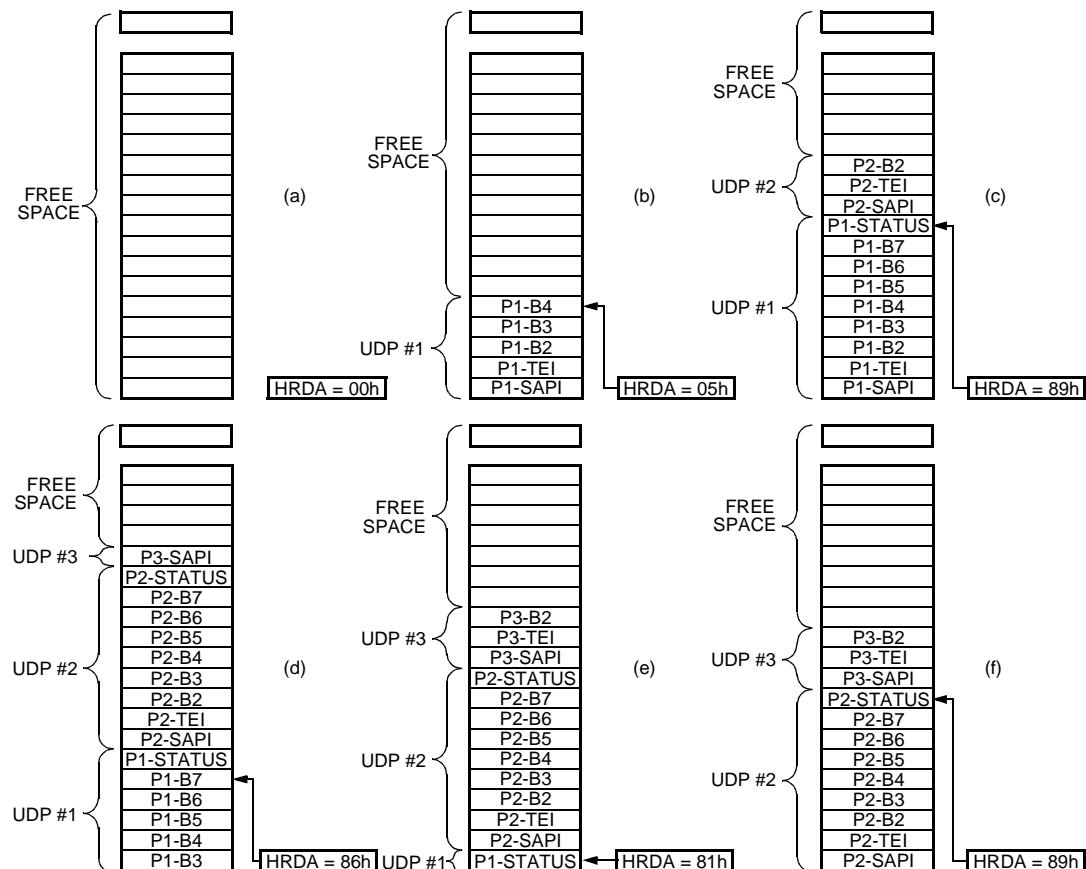

Figure 11. HDLC Receiver FIFO Snapshot Sequence

9 HDLC with FIFO Module (continued)

9.3 HDLC Receiver (continued)

9.3.1 HDLC Receiver Initialization (continued)

Up to 16 status bytes can be stored in the receiver FIFO at a given time. Once this condition is reached, it is indicated by assertion of the HIR[RSTF] interrupt register bit and the FIFO is considered full. In the worst case, the microcontroller has approximately 2 ms from the time HIR[RSTF] is asserted to read data from the FIFO and avoid overrun errors (an overrun error is indicated by assertion of the HIR[ROVR] interrupt bit).

When a status word with its EOF bit set is loaded into the FIFO, interrupt bit HIR[REOF] is set. Similarly, when a status word with its ABRT bit set is loaded into the FIFO, interrupt bit HIR[RABT] is set.

When the receive FIFO is filled at or above the level programmed in register HRTM, an interrupt is asserted by enabling the bit HIR[RTHR]. The interrupt should clear when the interrupt status register is read, and should not be asserted again until the receive FIFO is emptied to the point that more spaces remain in the FIFO than the value programmed in the HRTM register, and then enough bytes are received to again cause the delay FIFO fill level to reach the HRTM register value.

9.3.1.1 Overrun Condition

An overrun condition occurs when the receiver is unable to download a processed byte into the FIFO because the FIFO is full or contains 16 status words. Interrupt bit HIR[ROVR] is set when an overrun occurs. If the overrun condition occurs during the reception of a packet with a matching address field, the current frame will be closed and its status word's OVR bit will be set. The remainder of the frame will be dropped even if the overrun condition has been removed. The receiver must be reinitialized after the overrun condition, before new packets can be properly received.

9.4 Address Recognition

A very flexible address comparison scheme is implemented in the NTN device. Eight registers are used for storing SAPI or TEI patterns for comparison with the incoming address. The registers are grouped logically into the pairs HSM0/HTM0, HSM1/HTM1, HSM2/HTM2, HSM3/HTM3 to define a total of four DLCI (data link connection identifier) address matching patterns. If HSMOD and HTMOD are programmed for address

matching, only frames with an address field matching one of the programmed address values (or special addresses) are transferred to the receive FIFO. All others are ignored. If an address match occurs, the address field is also loaded into the HDLC receive FIFO.

The address modifier registers, HSMOD and HTMOD, are used to control the address recognition modes and can be used to extend the DLCIs defined in the four HSMx/HTMx register pairs. Figure 12 shows an example of this for the SAPI0/TEI0 pair (i.e., bits SAPI0M[1:0] and TEI0M[1:0] in HSMOD and HTMOD, respectively).

Consider the default setting of TEI0M = 00 and SAPI0M = 00 on powerup. In this case, TEI0M = 00 causes rejection of all packets for a given DLCI pair, independent of the state of SAPI0M. This means that on powerup, the HDLC receiver is disabled and will not receive any packets. Now consider the effect of setting TEI0M to the other three possible values while leaving SAPI0M set to 00.

Setting TEI0M = 01 enables the recognition of the DLCI0 address programmed in the HSM0/HTM0 pair. Setting TEI0M = 10 extends the definition of DLCI0 to include the broadcast TEI value, 127. Setting TEI0M = 11 extends the definition of DLCI0 to include all TEI values.

In a similar way, setting SAPI0M to the values 01, 10, or 11 will extend the existing definition of DLCI0 to include SAPI0 = 0, SAPI = 63, or all SAPI values, respectively. Note, then, that when SAPI0M/TEI0M = 1111, any packet more than 2 bytes in length (4 bytes if HRCF[DROPCRC] = 1) will be downloaded to the receiver FIFO, regardless of its address. This effectively disables address recognition for all four DLCI pairs, since the values programmed into the other three pairs become irrelevant in this case.

One further level of address recognition control is available via the HSCR register, which provides a means for enabling/disabling comparison of the command response (C/R) bit for each SAPI. When HSCR[SxCRE] = 0, no comparison is done on the C/R bit of the SAPI defined by HSMx register. When HSCR[SXCRE] = 1, the C/R bit is included in comparison. However, for extended SAPI values of 0 or 63 (HSMOD[SAPIxM] = 01 or = 10), no comparison is ever done on the C/R bit.

In the transmit direction, no automatic address insertion is performed.

9 HDLC with FIFO Module (continued)

9.4 Address Recognition (continued)

		TEI0M			
		00	01	10	11
S A P I O M	00		SAPI0 TEI0	SAPI0 TEI0 SAPI0 127	SAPI0 †
	01		SAPI0 TEI0	SAPI0 TEI0 SAPI0 127	SAPI0 †
			0 TEI0	0 TEI0 0 127	0 †
	10		SAPI0 TEI0	SAPI0 TEI0 SAPI0 127	SAPI0 †
		63 TEI0	63 TEI0 63 127	63 †	
11		* TEI0	* TEI0 * 127	* †	

* Indicates any SAPI value.
† Indicates any TEI value.

5-6514F

Figure 12. DLCI Extension and Function of SAPI0M-TEI0M Bits

9 HDLC with FIFO Module (continued)

9.5 HDLC Register Set

Table 55. HTCF: HDLC Transmitter Configuration Register (0x18)

Reg	R/W	Bit 7	Bit 6	Bit 5	Bit 4	Bit 3	Bit 2	Bit 1	Bit 0
HTCF	R/W	FCNT2	FCNT1	FCNT0	IDL	TXMODE	ABRT_RQ	MANCRC	TX_INIT
RESET	Default	0	0	0	1	0	0	0	0

Bit #	Symbol	Name/Description
7—5	FCNT[2:0]	<p>Interframe Fill Count. Sets the number of fill bytes to be transmitted between each HDLC frame. The number of fill bytes inserted between the closing flag of one frame and the opening flag of another is FCNT[2:0] – 1, except for the case of FCNT[2:0] = 0, which causes sharing of the closing flag of one frame with the opening flag of the next.</p> <p>000: Back-to-back frames (closing/opening flag is shared). 001: No fill bytes are inserted. ... 111: Insert 6 fill bytes.</p> <p>Back-to-back frames can only occur if the priority mechanism is disabled by setting DFR[FORCE_D] = 1. See DFR[FORCE_D] description.</p>
4	IDL	<p>Idle/Interframe Fill Value. Sets the value of the transmitter's idle and interframe fill bytes.</p> <p>0: 01111110 (flags) 1: 11111111 (idles)</p> <p>Flags can only be used as idle or interframe fill bytes if the priority mechanism is disabled by setting DFR[FORCE_D] = 1. See DFR[FORCE_D] description.</p>
3	TXMODE	<p>Transmitter Mode. Determines whether the transmitter is in standard HDLC mode or transparent mode. The transmitter must be reinitialized after changing this bit.</p> <p>0: Standard HDLC mode. 1: Transparent mode.</p>
2	ABRT_RQ	<p>HDLC Transmitter Abort Request. When this signal is written to 1, the frame currently being transmitted is aborted and the transmit FIFO will be flushed. This bit automatically returns to 0 once the abort sequence has been set.</p>
1	MANCRC	<p>HDLC Transmitter Manual/Auto CRC Insertion. Controls whether the transmit FCS (CRC) will be inserted automatically by the HDLC controller or whether it must be manually loaded into the transmit FIFO. The transmitter must be reinitialized after changing this bit.</p> <p>0: Auto insertion. 1: Manual insertion.</p>
0	TX_INIT	<p>HDLC Transmitter Initialize. Writing this bit to 1 will cause initialization of the HDLC transmitter. On powerup, the HDLC transmitter is initialized automatically. After powerup, whenever the MANCRC or TXMODE configuration bits are changed, this bit needs to be set to reinitialize the HDLC transmitter. Prior to programming any of the transmitter registers, this bit must be written to 1. The microcontroller must then poll this bit and wait until it returns to 0 (signaling that transmitter initialization is complete) before programming any of the other transmitter registers.</p>

9 HDLC with FIFO Module (continued)

9.5 HDLC Register Set (continued)

Table 56. HRCF: HDLC Receiver Configuration Register (0x19)

Reg	R/W	Bit 7	Bit 6	Bit 5	Bit 4	Bit 3	Bit 2	Bit 1	Bit 0
HRCF	R/W	—	—	—	—	RXMODE	BAE	DROPCRC	RX_INIT
RESET	Default	0	0	0	0	0	0	1	0

Bit #	Symbol	Name/Description
7—4	—	Reserved. Program to 0.
3	RXMODE	Receiver Mode. Determines whether the receiver is in standard HDLC mode or transparent mode. The receiver must be reinitialized after changing this bit. 0: Standard HDLC mode. 1: Transparent mode.
2	BAE	Byte Alignment Enable. This bit enables the byte alignment feature for the HDLC receiver when operating in transparent mode. When this feature is enabled, register HSM0 (22h) provides the byte alignment pattern. The receiver must be reinitialized after changing this bit. 0: Byte alignment mechanism is disabled. 1: Byte alignment mechanism is enabled.
1	DROPCRC	Drop Receive CRC. Controls whether the CRC bytes (last 2 bytes of an HDLC frame) are loaded into the receive FIFO. The receiver must be reinitialized after changing this bit. 0: Load 2 CRC bytes into receive FIFO. 1: Drop CRC (CRC bytes are not loaded into the receive FIFO).
0	RX_INIT	HDLC Receiver Initialize. Writing this bit to 1 will cause initialization of the HDLC receiver. On powerup, the HDLC receiver is initialized automatically. After powerup, whenever there is any change in the DROPCRC, RXMODE, BAE, or HSM0[BAP(7:0)] configuration bits, this bit needs to be set to reinitialize the HDLC receiver. Prior to programming any of the receiver registers, this bit must be written to 1. The microcontroller must then poll this bit and wait until it returns to 0 (signaling that receiver initialization is complete) before programming any of the other receiver registers. During initialization, DROPCRC is latched. Any change to DROPCRC after initialization is disregarded.

9 HDLC with FIFO Module (continued)

9.5 HDLC Register Set (continued)

Table 57. HTH: HDLC Transmit FIFO Threshold (0x1A)

Reg	R/W	Bit 7	Bit 6	Bit 5	Bit 4	Bit 3	Bit 2	Bit 1	Bit 0
HTH	R/W	P_CLASS	—	TFAE5	TFAE4	TFAE3	TFAE2	TFAE1	TFAE0
RESET	Default	1	0	1	0	0	0	0	0

Bit #	Symbol	Name/Description
7	P_CLASS	Priority Class. This bit is used during arbitration to the upstream D-channel access. It indicates the number of consecutive ones the NTN has to receive on the upstream S/T D channel in order to grant D-channel access to the HDLC transmitter. 0: Priority class 2 (data) as defined in ITU-I.430. 1: Priority class 1 (signaling) as defined in ITU-I.430. Within a class, priority levels are automatically managed.
6	—	Reserved. Program to 0.
5—0	TFAE[5:0]	HDLC Transmitter FIFO Almost Empty Threshold. The HDLC transmitter will issue an interrupt (if enabled) when the number of empty bytes in the transmit FIFO exceeds the threshold level programmed in this register. The interrupt will clear when the interrupt status register is read. The interrupt will not be asserted again until the number of empty bytes in the transmit FIFO is equal to or less than the value programmed in TFAE[5:0], and then enough bytes are transmitted to again cause the FIFO empty level to exceed the TFAE[5:0] value.

Table 58. HRT: HDLC Receive FIFO Threshold (0x1B)

Reg	R/W	Bit 7	Bit 6	Bit 5	Bit 4	Bit 3	Bit 2	Bit 1	Bit 0
HRT	R/W	—	—	RFAF5	RFAF4	RFAF3	RFAF2	RFAF1	RFAF0
RESET	Default	0	0	1	0	0	0	0	0

Bit #	Symbol	Name/Description
7—6	—	Reserved. Program to 0.
5—0	RFAF[5:0]	HDLC Receiver FIFO Almost Full Threshold. The HDLC receiver will issue an interrupt (if enabled) when the number of bytes in the receive FIFO exceeds the threshold level programmed in this register. The interrupt will clear when the interrupt status register is read. The interrupt will not be asserted again until the number of bytes in the receive FIFO is equal to or less than the value programmed in RFAF[5:0], and enough bytes are received to again cause the FIFO fill level to exceed the RFAF[5:0] value.

9 HDLC with FIFO Module (continued)

9.5 HDLC Register Set (continued)

Table 59. HTSA: HDLC Transmit FIFO Space Available (0x1C)

Reg	R/W	Bit 7	Bit 6	Bit 5	Bit 4	Bit 3	Bit 2	Bit 1	Bit 0
HTSA	R	—	TSP6	TSP5	TSP4	TSP3	TSP2	TSP1	TSP0
RESET	Default	—	1	0	0	0	0	0	0

Bit #	Symbol	Name/Description
7	—	Reserved.
6—0	TSP[6:0]	Transmitter Space. This register contains the number of empty positions in the transmitter FIFO.

Table 60. HRDA: HDLC Receive FIFO Data Available (0x1D)

Reg	R/W	Bit 7	Bit 6	Bit 5	Bit 4	Bit 3	Bit 2	Bit 1	Bit 0
HRDA	R	SWRF	NBNSW6	NBNSW5	NBNSW4	NBNSW3	NBNSW2	NBNSW1	NBNSW0
RESET	Default	—	—	—	—	—	—	—	—

Bit #	Symbol	Name/Description
7	SWRF	Status Word on Receive FIFO. The HDLC receiver module asserts this bit whenever there is a status word in the receive FIFO. 0: No status word. 1: Status word.
6—0	NBNSW[6:0]	Number of Bytes Until Next Status Word. These bits indicate how many bytes are present in the receive FIFO. If SWRF (bit 7) is equal to 1, indicating that a status word is available in the FIFO, then NBNSW[6:0] indicates the number of bytes in the receive FIFO up to and including the status byte. If SWRF is equal to 0, indicating that no status words are available in the FIFO, then NBNSW[6:0] indicates the total number of data bytes in the receive FIFO.

Table 61. HTX: HDLC Transmit Data (0x1E)

Reg	R/W	Bit 7	Bit 6	Bit 5	Bit 4	Bit 3	Bit 2	Bit 1	Bit 0
HTX	W	TXD7	TXD6	TXD5	TXD4	TXD3	TXD2	TXD1	TXD0
RESET	Default	—	—	—	—	—	—	—	—

Bit #	Symbol	Name/Description
7—0	TXD[7:0]	HDLC Transmit Data. Data to be transmitted is written to this register, which maps into the transmit FIFO. The last byte of each packet must be written to register HTXL (see Table 62).

9 HDLC with FIFO Module (continued)

9.5 HDLC Register Set (continued)

Table 62. HTXL: HDLC Transmit Data Last Byte (0x1F)

Reg	R/W	Bit 7	Bit 6	Bit 5	Bit 4	Bit 3	Bit 2	Bit 1	Bit 0
HTXL	W	TXDL7	TXDL6	TXDL5	TXDL4	TXDL3	TXDL2	TXDL1	TXDL0
RESET	Default	—	—	—	—	—	—	—	—

Bit #	Symbol	Name/Description
7—0	TXDL[7:0]	HDLC Transmit Data—Last Byte. The last data byte of each transmitted packet is written to this register (rather than HTX) to indicate to the transmitter that this is the end of the packet. This register occupies the same physical space as HTX (i.e., it maps to the transmit FIFO).

Table 63. HRX: HDLC Receive Data (0x20)

Reg	R/W	Bit 7	Bit 6	Bit 5	Bit 4	Bit 3	Bit 2	Bit 1	Bit 0
HRX	R	RXD7	RXD6	RXD5	RXD4	RXD3	RXD2	RXD1	RXD0
RESET	Default	—	—	—	—	—	—	—	—

Bit #	Symbol	Name/Description
7—0	RXD[7:0]	Received Data/Status. The content of the FIFO is read when addressing this register. The first received bit is the least significant bit of this byte.

Table 64. HSCR: HDLC SAPI C/R Bit Mask (0x21)

Reg	R/W	Bit 7	Bit 6	Bit 5	Bit 4	Bit 3	Bit 2	Bit 1	Bit 0
HSCR	R/W	—	—	—	—	S3CRE	S2CRE	S1CRE	S0CRE
RESET	Default	0	0	0	0	0	0	0	0

Bit #	Symbol	Name/Description
7—4	—	Reserved. Program to 0.
3	S3CRE	SAPI3 Command/Response Bit Comparison Enable. 0: SAPI3 C/R bit is ignored. 1: SAPI3 comparison includes C/R bit (HSM3.1).
2	S2CRE	SAPI2 Command/Response Bit Comparison Enable. 0: SAPI2 C/R bit is ignored. 1: SAPI2 comparison includes C/R bit (HSM2.1).
1	S1CRE	SAPI1 Command/Response Bit Comparison Enable. 0: SAPI1 C/R bit is ignored. 1: SAPI1 comparison includes C/R bit (HSM1.1).
0	S0CRE	SAPI0 Command/Response Bit Comparison Enable. 0: SAPI0 C/R bit is ignored. 1: SAPI0 comparison includes C/R bit (HSM0.1).

9 HDLC with FIFO Module (continued)

9.5 HDLC Register Set (continued)

Table 65. HSM0: HDLC SAPI Match Pattern 0 (0x22)

Reg	R/W	Bit 7	Bit 6	Bit 5	Bit 4	Bit 3	Bit 2	Bit 1	Bit 0
HSM0	R/W	SAPI05	SAPI04	SAPI03	SAPI02	SAPI01	SAPI00	C/R0	EA00
		BAP7	BAP6	BAP5	BAP4	BAP3	BAP2	BAP1	BAP0
RESET	Default	—	—	—	—	—	—	—	—

Bit #	Symbol	Name/Description
7—2	SAPI0[5:0]	Match Pattern 0 for SAPI. When in the HDLC mode, this register provides the match pattern for SAPI. See Section 9.4, Address Recognition for details.
	BAP[7:2]	Byte Alignment Pattern. When in transparent mode, this register provides the byte alignment pattern if HRCF[BAE] = 1.
1	C/R0	Command/Response Bit. Set according to the Q.920 standard.
	BAP1	Byte Alignment Pattern. When in transparent mode, this register provides the byte alignment pattern if HRCF[BAE] = 1.
0	EA00	Address Field Extension Bit (0 or 1). This bit has to be 0 for recognizing SAPI0 and SAPI63 addresses.
	BAP0	Byte Alignment Pattern. When in transparent mode, this register provides the byte alignment pattern if HRCF[BAE] = 1.

Table 66. HTM0: HDLC TEI Match Pattern 0 (0x23)

Reg	R/W	Bit 7	Bit 6	Bit 5	Bit 4	Bit 3	Bit 2	Bit 1	Bit 0
HTM0	R/W	TEI06	TEI05	TEI04	TEI03	TEI02	TEI01	TEI00	EA10
RESET	Default	—	—	—	—	—	—	—	—

Bit #	Symbol	Name/Description
7—1	TEI0[6:0]	Match Pattern 0 for TEI. See Section 9.4, Address Recognition for details.
0	EA10	Address Field Extension Bit (0 or 1). This bit has to be 1 for recognizing the special TEI127 value of 127.

Table 67. HSM1: HDLC SAPI Match Pattern 1 (0x24)

Reg	R/W	Bit 7	Bit 6	Bit 5	Bit 4	Bit 3	Bit 2	Bit 1	Bit 0
HSM1	R/W	SAPI15	SAPI14	SAPI13	SAPI12	SAPI11	SAPI10	C/R1	EA01
RESET	Default	—	—	—	—	—	—	—	—

Bit #	Symbol	Name/Description
7—2	SAPI1[5:0]	Match Pattern 1 for SAPI. When in the HDLC mode, this register provides the match pattern for SAPI. See Section 9.4, Address Recognition for details.
1	C/R1	Command/Response Bit. Set according to the Q.920 standard.
0	EA01	Address Field Extension Bit (0 or 1). This bit has to be 0 for recognizing SAPI0 and SAPI63 addresses.

9 HDLC with FIFO Module (continued)

9.5 HDLC Register Set (continued)

Table 68. HTM1: HDLC TEI Match Pattern 1 (0x25)

Reg	R/W	Bit 7	Bit 6	Bit 5	Bit 4	Bit 3	Bit 2	Bit 1	Bit 0
HTM1	R/W	TEI16	TEI15	TEI14	TEI13	TEI12	TEI11	TEI10	EA11
RESET	Default	—	—	—	—	—	—	—	—

Bit #	Symbol	Name/Description
7—1	TEI1[6:0]	Match Pattern 1 for TEI. See Section 9.4, Address Recognition for details.
0	EA11	Address Field Extension Bit (0 or 1). This bit has to be 1 for recognizing the special TEI value of 127.

Table 69. HSM2: HDLC SAPI Match Pattern 2 (0x26)

Reg	R/W	Bit 7	Bit 6	Bit 5	Bit 4	Bit 3	Bit 2	Bit 1	Bit 0
HSM2	R/W	SAPI25	SAPI24	SAPI23	SAPI22	SAPI21	SAPI20	C/R2	EA02
RESET	Default	—	—	—	—	—	—	—	—

Bit #	Symbol	Name/Description
7—2	SAPI2[5:0]	Match Pattern 2 for SAPI. When in the HDLC mode, this register provides the match pattern for SAPI. See Section 9.4, Address Recognition for details.
1	C/R2	Command/Response Bit. Set according to the Q.920 standard.
0	EA02	Address Field Extension Bit (0 or 1). This bit has to be 0 for recognizing special SAPI values of 0 or 63.

Table 70. HTM2: HDLC TEI Match Pattern 2 (0x27)

Reg	R/W	Bit 7	Bit 6	Bit 5	Bit 4	Bit 3	Bit 2	Bit 1	Bit 0
HTM2	R/W	TEI26	TEI25	TEI24	TEI23	TEI22	TEI21	TEI20	EA12
RESET	Default	—	—	—	—	—	—	—	—

Bit #	Symbol	Name/Description
7—1	TEI2[6:0]	Match Pattern 2 for TEI. See Section 9.4, Address Recognition for details.
0	EA12	Address Field Extension Bit (0 or 1). This bit has to be 1 for recognizing the special TEI value of 127.

Table 71. HSM3: HDLC SAPI Match Pattern 3 (0x28)

Reg	R/W	Bit 7	Bit 6	Bit 5	Bit 4	Bit 3	Bit 2	Bit 1	Bit 0
HSM3	R/W	SAPI35	SAPI34	SAPI33	SAPI32	SAPI31	SAPI30	C/R3	EA03
RESET	Default	—	—	—	—	—	—	—	—

Bit #	Symbol	Name/Description
7—2	SAPI3[5:0]	Match Pattern 3 for SAPI. When in the HDLC mode, this register provides the match pattern for SAPI. See Section 9.4, Address Recognition for details.
1	C/R3	Command/Response Bit. Set according to the Q.920 standard.
0	EA03	Address Field Extension Bit (0 or 1). This bit has to be 0 for recognizing special SAPI values of 0 or 63.

9 HDLC with FIFO Module (continued)

9.5 HDLC Register Set (continued)

Table 72. HTM3: HDLC TEI Match Pattern 3 (0x29)

Reg	R/W	Bit 7	Bit 6	Bit 5	Bit 4	Bit 3	Bit 2	Bit 1	Bit 0
HTM3	R/W	TEI36	TEI35	TEI34	TEI33	TEI32	TEI31	TEI30	EA13
RESET	Default	—	—	—	—	—	—	—	—

Bit #	Symbol	Name/Description
7—1	TEI3(6—0)	Match Pattern 3 for TEI. See Section 9.4, Address Recognition for details.
0	EA13	Address Field Extension Bit (0 or 1). This bit has to be 1 for recognizing the special TEI value of 127.

Table 73. HSMOD: HDLC SAPI Modifier Register (0x2A)

See Section 9.4, Address Recognition for details on the function of this register.

Reg	R/W	Bit 7	Bit 6	Bit 5	Bit 4	Bit 3	Bit 2	Bit 1	Bit 0
HSMOD	R/W	SAPI3M1	SAPI3M0	SAPI2M1	SAPI2M0	SAPI1M1	SAPI1M0	SAPI0M1	SAPI0M0
RESET	Default	0	0	0	0	0	0	0	0

Bit #	Symbol	Name/Description
7—6	SAPI3M[1:0]	SAPI3 Modifier. This field indicates the value(s) for the SAPI of DLCI3. 00: SAPI3 = value of HSM3. 01: SAPI3 = value of HSM3 or 0. 10: SAPI3 = value of HSM3 or 63. 11: SAPI3 = any value.
5—4	SAPI2M[1:0]	SAPI2 Modifier. This field indicates the value(s) for the SAPI of the DLCI2. 00: SAPI2 = value of HSM2. 01: SAPI2 = value of HSM2 or 0. 10: SAPI2 = value of HSM2 or 63. 11: SAPI2 = any value.
3—2	SAPI1M[1:0]	SAPI1 Modifier. This field indicates the value(s) for the SAPI of the DLCI1. 00: SAPI1 = value of HSM1. 01: SAPI1 = value of HSM1 or 0. 10: SAPI1 = value of HSM1 or 63. 11: SAPI1 = any value.
1—0	SAPI0M[1:0]	SAPI0 Modifier. This field indicates the value(s) for the SAPI of the DLCI0. 00: SAPI0 = value of HSM0. 01: SAPI0 = value of HSM0 or 0. 10: SAPI0 = value of HSM0 or 63. 11: SAPI0 = any value.

9 HDLC with FIFO Module (continued)

9.5 HDLC Register Set (continued)

Table 74. HTMOD: HDLC TEI Modifier Register (0x2B)

See Section 9.4, Address Recognition for details on the function of this register.

Reg	R/W	Bit 7	Bit 6	Bit 5	Bit 4	Bit 3	Bit 2	Bit 1	Bit 0
HTMOD	R/W	TEI3M1	TEI3M0	TEI2M1	TEI2M0	TEI1M1	TEI1M0	TEI0M1	TEI0M0
RESET	Default	0	0	0	0	0	0	0	0

Bit #	Symbol	Name/Description
7—6	TEI3M[1:0]	TEI3 Modifier. This field indicates the value(s) for the TEI of DLCI3. 00: DLCI3 not defined. 01: TEI3 = value of HTM3. 10: TEI3 = value of HTM3 or broadcast TEI (127). 11: TEI3 = any value.
5—4	TEI2M[1:0]	TEI2 Modifier. This field indicates the value(s) for the TEI of DLCI2. 00: DLCI2 not defined. 01: TEI2 = value of HTM2. 10: TEI2 = value of HTM2 or broadcast TEI (127). 11: TEI2 = any value.
3—2	TEI1M[1:0]	TEI1 Modifier. This field indicates the value(s) for the TEI of DLCI1. 00: DLCI1 not defined. 01: TEI1 = value of HTM1. 10: TEI1 = value of HTM1 or broadcast TEI (127). 11: TEI1 = any value.
1—0	TEI0M[1:0]	TEI0 Modifier. This field indicates the value(s) for the TEI of DLCI0. 00: DLCI0 not defined. 01: TEI0 = value of HTM0. 10: TEI0 = value of HTM0 or broadcast TEI (127). 11: TEI0 = any value.

9 HDLC with FIFO Module (continued)

9.5 HDLC Register Set (continued)

Table 75. HIR: HDLC Interrupt Register (0x2C)

Reg	R/W	Bit 7	Bit 6	Bit 5	Bit 4	Bit 3	Bit 2	Bit 1	Bit 0
HIR	R	RSTF	ROVR	REOF	RABT	RTHR	TUNDR	TFC	TTHR
RESET	Default	—	—	—	—	—	—	—	—

Note: All bits in this register are set to 1 upon occurrence of the corresponding interrupt condition, and are cleared to 0 when the register is read.

Bit #	Symbol	Name/Description
7	RSTF	Receiver Status Full Interrupt. This interrupt occurs when the receiver FIFO is filled with 16 status bytes.
6	ROVR	Receive FIFO Overrun Interrupt. This interrupt occurs when a received byte is written to a full receive FIFO.
5	REOF	Receive End of Frame Interrupt. This interrupt occurs when an end of frame (EOF) status byte is written to the receive FIFO.
4	RABT	Receive Abort Detect Interrupt. This interrupt occurs when the receiver detects an abort condition.
3	RTHR	Receive FIFO Threshold Interrupt. This interrupt occurs when the receiver almost full threshold is exceeded.
2	TUNDR	Transmit FIFO Underrun Interrupt. This interrupt occurs when the transmitter attempts to transmit a byte from an empty transmit FIFO.
1	TFC	Transmit Frame Complete Interrupt. This interrupt occurs when the transmitter has successfully transmitted a frame.
0	TTHR	Transmit FIFO Threshold Interrupt. This interrupt occurs when the transmitter almost empty threshold is exceeded.

9 HDLC with FIFO Module (continued)

9.5 HDLC Register Set (continued)

Table 76. HIE: HDLC Interrupt Enable 15 (0x2D)

Reg	R/W	Bit 7	Bit 6	Bit 5	Bit 4	Bit 3	Bit 2	Bit 1	Bit 0
HIE	R/W	RSTFE	ROVRE	REOFE	RABTE	RTHRE	TUNDRE	TFCE	TTHRE
RESET	Default	0	0	0	0	0	0	0	0

Bit #	Symbol	Name/Description
7	RSTFE	RSTFE Interrupt Enable. 0: Interrupt disabled. 1: Interrupt enabled.
6	ROVRE	ROVR Interrupt Enable. 0: Interrupt disabled. 1: Interrupt enabled.
5	REOFE	REOF Interrupt Enable. 0: Interrupt disabled. 1: Interrupt enabled.
4	RABTE	RABT Interrupt Enable. 0: Interrupt disabled. 1: Interrupt enabled.
3	RTHRE	RTHR Interrupt Enable. 0: Interrupt disabled. 1: Interrupt enabled.
2	TUNDRE	TUNDR Interrupt Enable. 0: Interrupt disabled. 1: Interrupt enabled.
1	TFCE	TFC Interrupt Enable. 0: Interrupt disabled. 1: Interrupt enabled.
0	TTHRE	TTHR Interrupt Enable. 0: Interrupt disabled. 1: Interrupt enabled.

10 GCI+ Interface Module

The programmable GCI+ interface supports a large variety of codec interfaces, including GCI, long-frame sync (LFS) TDM, and short-frame sync (SFS) TDM; hence, the + attribute. These interfaces cover most available codecs on the marketplace (Lucent, *Siemens*, *National**, and *Motorola†*).

The GCI+ interface is comprised of seven signals as shown in Table 77. The pin routing of the FSC and PFS1 signals changes slightly depending on whether the device is in TDM or GCI mode. This was done in order to place the signal most likely to be used in each mode on the FS1 pin rather than the GPIO2.2 pin. This allows the GPIO2.2 signal to be available for other uses in most cases.

Table 77. GCI+ Interface Signals

Function Name	GCI Pin	TDM Pin	I/O	Meaning
FSC	FS1	GPIO2.2	O	Reference frame sync (marks start of frame).
PFS1	GPIO2.2	FS1	O	Programmable frame sync 1 (marks location of B1 channel).
PFS2	FS2	FS2	O	Programmable frame sync 2 (marks location of B2 channel).
DCL	DCL	DCL	O	Data clock (defined with GRATE bits).
BCLK	GPIO2.1	GPIO2.1	O	Bit clock (only active during 2 times data clock mode).
DU	DU	DU	I	Data upstream (U transmit data).
DD	DD	DD	O	Data downstream (U receive data).

The GCI+ interface behavior depends on the operational mode defined by its configuration register, GCCF. Three modes are supported by the GCI+ interface:

- GCI-NT mode (GCCF[GMODE(1:0)] = 00).
- GCI-TE mode (GCCF[GMODE(1:0)] = 01).
- TDM mode (GCCF[GMODE(1:0)] = 1x).

10.1 TDM Mode (GCCF, GMODE[1:0] = 1x)

TDM mode is for use with codecs having a simple TDM interface. Figure 13 and Figure 14 show the timing for the GCI+ interface when programmed in TDM mode.

There are two clock modes for the data clock, DCL: single clock and double clock mode. In single clock mode (GCCF[CKMODE] = 1), there is one DCL cycle per bit. In double clock mode (GCCF[CKMODE] = 0), there are two DCL cycles per bit. The DCL clock rate is programmed via the GCCF[GRATE(1:0)] register bits. The DCL rates supported in TDM mode are 512 kHz, 1536 kHz, or 2048 kHz. Since there can be either one or two DCL cycles per data bit, depending on whether the GCI+ is in single or double clock mode, there are six possible data rates, as shown in Table 78. In addition, a powerdown mode is available in which DCL is stopped (see Section 10.5, GCI+ Powerdown Mode).

In double clock mode, a bit clock (BCLK) signal is available on the GPIO2.1 pin when GPAF1[GPAF2.1] = 1. BCLK occurs once per bit time and is a divide-by-two version of the DCL signal. BCLK is always 0 in single clock mode.

* *National* is a registered trademark of National Semiconductor Corporation.

† *Motorola* is a registered trademark of Motorola, Inc.

10 GCI+ Interface Module (continued)

10.1 TDM Mode (GCCF, GMODE[1:0] = 1x) (continued)

Table 78. TDM Data Rate and Clock Options

CKMODE	GRATE	DCL Rate (kHz)	BCLK Rate (kHz)	Data Rate (kHz)	Number of 8-bit Time Slots
0	00	0	0	0	0
0	01	512	256	256	4
0	10	1536	768	768	12
0	11	2048	1024	1024	16
1	00	0	0	0	0
1	01	512	0	512	8
1	10	1536	0	1536	24
1	11	2048	0	2048	32

In TDM mode, the FSC signal can provide an envelope of time slot #0 (the first time slot of a frame) via the GPIO2.2 pin by setting GPAF1[GPAF2.2] = 1. The PFS1 and PFS2 signals mark the location of the B1 and B2 time slots on the TDM highway and are output on the FS1 and FS2 pins, respectively (see Table 78).

The PFS1 and PFS2 (programmable frame sync) signals may be programmed to be a pulse (duration of one bit period, sometimes referred to as short frame sync) or envelope (duration of one time slot minus one-half of a DCL period, sometimes referred to as long frame sync). Register bit GCCF[PFSPE] sets the short or long frame sync mode.

The B1 and B2 time slots may be programmed to be at any offset from the start of the frame (in time-slot increments) by programming the GCOF1 and GCOF2 registers with the desired offset.

The U-interface B1 and B2 channels are normally transferred to/from the codec on the time slots marked by PFS1 and PFS2, respectively. This ordering can be switched by setting the DFAC[BSWAP] register bit to 1.

Register bit GCCF[PFSPE] = 1 controls the relative delay between PFS_x (x = 1 or x = 2) and the first data bit of the time slot associated with PFS_x. When GCCF[PFSDDEL] = 0, the PFS_x rising edge is coincident with the start of the first data bit of the corresponding time slot. When GCCF[PFSDDEL] = 1, the PFS_x rising edge occurs one data bit prior to the first data bit of the corresponding time slot.

Generation of the PFS_x signals and data transfer to/from the corresponding time slots may be disabled by setting DFR[PFS_x_ACT] = 0.

10 GCI+ Interface Module (continued)

10.1 TDM Mode (GCCF, GMODE[1:0] = 1x) (continued)

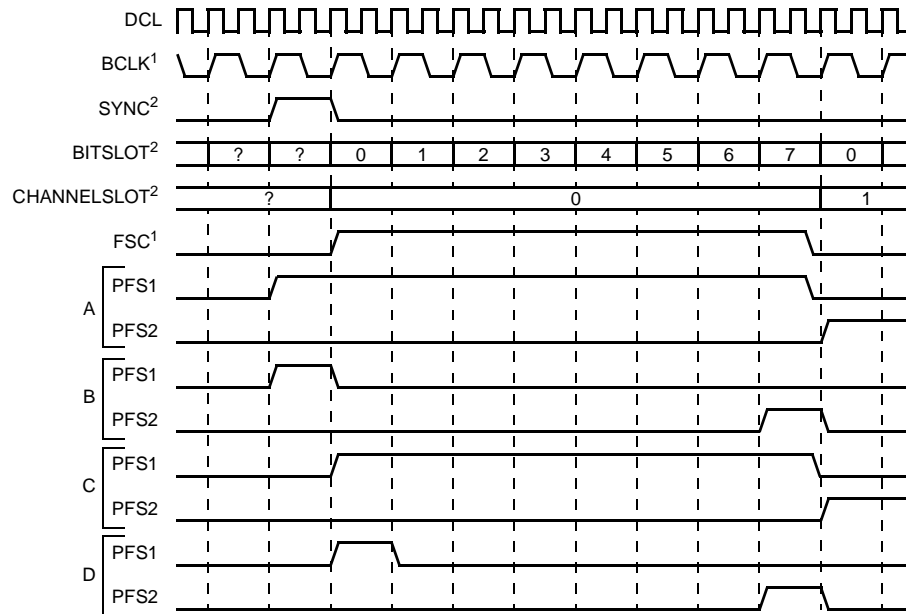

5-6722 (F)

1. Only present if programmed on GPAF1 register.

2. Not outputs. Shown only for reference.

Note: GKMODE = 0; OFF1 = 0; OFF2 = 1.

Key:

A: PFSDEL = 0 and PFSPE = 0.

B: PFSDEL = 0 and PFSPE = 1.

C: PFSDEL = 1 and PFSPE = 0.

D: PFSDEL = 1 and PFSPE = 1.

?: Don't care.

Figure 13. GCI+ Interface, TDM Mode Timing, Double Clock Mode: GCCF[CKMODE] = 0, GCCF[GMODE(1:0)] = 1x

10 GCI+ Interface Module (continued)

10.1 TDM Mode (GCCF, GMODE[1:0] = 1x) (continued)

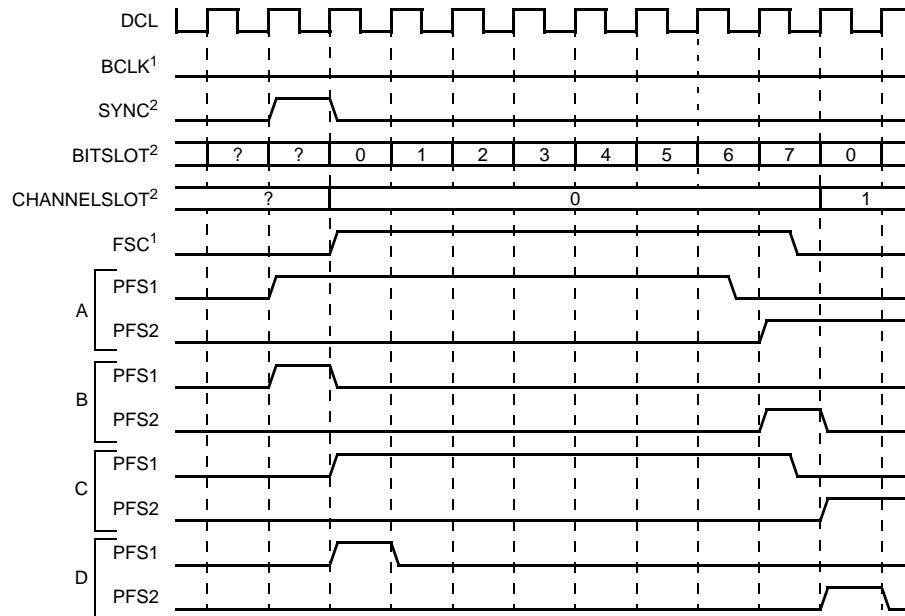

5-6719 (F)

- 1. Only present if programmed on GPAF1 register.
- 2. Not outputs. Shown only for reference.

Note: GKMODE = 1; OFF1 = 0; OFF2 = 1.

Key:

- A: PFSDEL = 0 and PFSPE = 0.
- B: PFSDEL = 0 and PFSPE = 1.
- C: PFSDEL = 1 and PFSPE = 0.
- D: PFSDEL = 1 and PFSPE = 1.
- ?: Don't care.

Figure 14. GCI+ Interface, TDM Mode Timing, Single Clock Mode: GCCF[CKMODE] = 1, GCCF[GMODE(1)] = 1

The figure below shows an example of how a codec with a TDM interface would be connected to an NTN device. The codec shown is the Lucent T8503 dual codec. The correct register settings are shown in the NTN block.

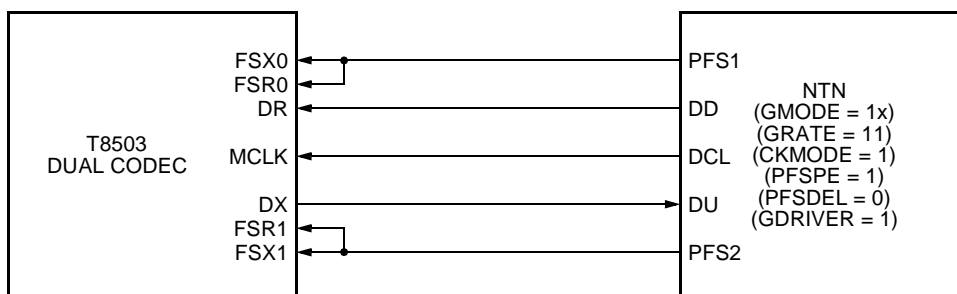

5-6720 (F)

Figure 15. NTN/T8503 Glueless TDM Interconnection

10 GCI+ Interface Module (continued)

10.2 GCI Modes (GCCF[GMODE(1:0)] = 0x)

GCI mode is for use with codecs having a GCI interface. Two GCI modes are supported by the NTN device:

- GCI-NT mode with a GCI frame structure of only one GCI channel.
- GCI-SCIT mode with a GCI frame structure of three GCI channels.

In both modes, the circuit operates as a GCI master device, i.e., the DCL output pin provides the GCI clock signal (512 kHz or 1536 kHz). A BCLK signal is available on the GPIO2.1 pin when GPAF1[GPAF2.1] = 1. BCLK occurs once per bit time and is a divide-by-two version of the DCL signal.

The FS1 output pin provides the frame synchronization clock (FSC) signal as defined by the GCI standard (see Figure 17). The internal PFS1 and PFS2 signals mark the location of the B1 and B2 time slots on the TDM highway. PFS2 is output on the FS2 pin (see Table 77). PFS1 can be made available on the GPIO2.2 pin by setting GPAF1[GPAF2.2] = 1.

The PFS1 and PFS2 (programmable frame sync) signals may be programmed to be a pulse (duration of one bit period, sometimes referred to as short frame sync) or envelope (duration of one time slot, sometimes referred to as long frame sync). Register bit GCCF[PFSDDEL] sets the short or long frame sync mode.

The U-interface B1 and B2 channels are normally transferred to/from the codec on the time slots marked by PFS1 and PFS2, respectively. This ordering can be switched by setting the DFAC[BSWAP] register bit to 1.

Register bit GCCF[PFSDDEL] controls the relative delay between PFS_x (x = 1 or x = 2) and the first data bit of the time slot associated with PFS_x. When GCCF[PFSDDEL] = 0, the PFS_x rising edge is coincident with the start of the first data bit of the corresponding time slot. When GCCF[PFSDDEL] = 1, the PFS_x rising edge occurs one data bit prior to the first data bit of the corresponding time slot.

Generation of the PFS_x signals and data transfer to/from the corresponding time slots may be disabled by setting DFR[PFS_x_ACT] = 0.

10.3 GCI-NT Mode (GCCF[GMODE(1:0)] = 00)

Figure 16 shows the frame structure for the GCI-NT mode. The DCL clock rate is automatically set to 512 kHz, overriding the value defined by GCCF[GRATE(1:0)]. In addition, a powerdown mode is available in which DCL is stopped (see Section 10.5, GCI+ Powerdown Mode).

The data rate in GCI-NT mode is automatically set to 256 kHz, overriding the value defined by GCCF[CKMODE]. A total of four 8-bit time slots are contained in each frame. Time slots 0 and 1 carry user data, time slot 2 is the GCI monitor (MON) channel, and time slot 3 is the GCI signaling and control channel.

The FS1 output pin provides the frame synchronization clock (FSC) as defined by the GCI standard. It becomes active with the rising edge of DCL at the start of time slot 0 and is turned off one-half of a DCL period prior to the start of time slot 1.

In this mode, the NTN device:

- May transfer upstream/downstream data on time-slots 0 and 1.
- Manages the MON channel's operation, maintenance, and data transfer (see Section 10.3.2, Monitor Message Transfer for more details).
- Provides control of the C/I subchannel (see Section 10.4, C/I Message Transfer for more details).

Register bit GCOF1[OFF10] controls the time slots to which PFS1 and PFS2 are associated. If GCOF1[OFF10] = 0 PFS1 occurs during time slot 0 (GCI-B1 channel) and PFS2 occurs during time slot 1 (GCI-B2 channel). If GCOF1[OFF10] = 1 the association is reversed, PFS1 occurs during time slot 1 (GCI-B2 channel) and the PFS2 occurs during time slot 0 (GCI-B1 channel). Note that the GCOF1(OFF1[4:1]) bits are ignored in GCI-NT mode, as is the entire GCOF2 register.

10 GCI+ Interface Module (continued)

10.3 GCI-NT Mode (GCCF[GMODE(1:0)] = 00) (continued)

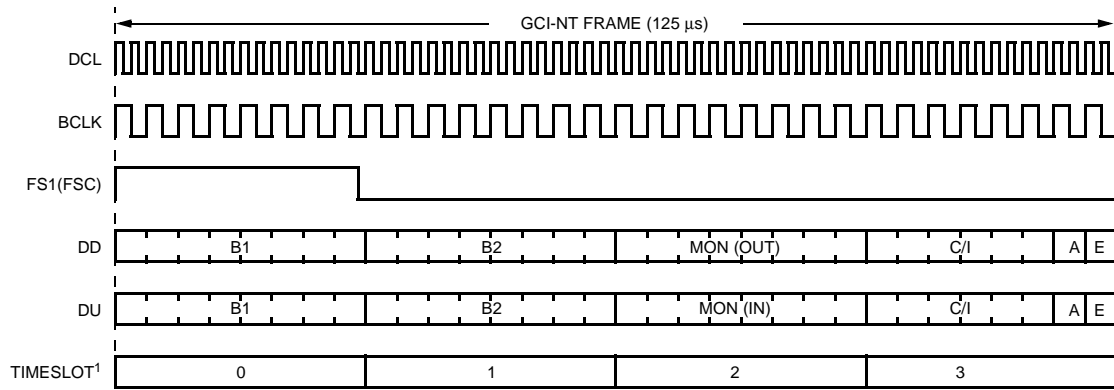

1. Not an output. Shown only for reference.

Note: GCCF[GMODE] = 00 (GCI-NT); DCL = 512 kHz; data rate = 256 kHz.

5-6721 (F)

Figure 16. GCI-NT Frame Structure

Figure 17 shows the generation of PFS1/PFS2 signals, assuming GCOF1[OFF10] = 0.

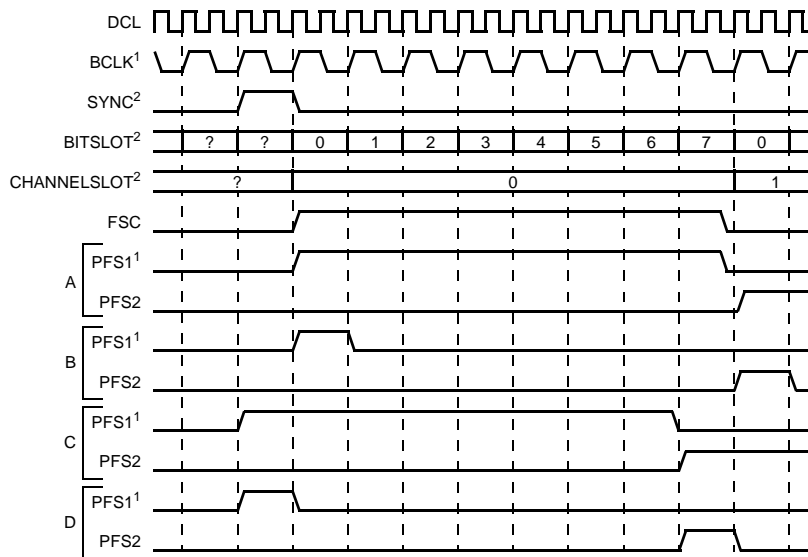

1. Only present if programmed on GPAF1 register.

2. Not outputs. Shown only for reference.

Note: GMODE = 00; CKRATE ≠ 00; GKMODE = X; OFF1 (0) = 0.

Key:

A: PFSDEL = 0 and PFSPE = 0

B: PFSDEL = 0 and PFSPE = 1

C: PFSDEL = 1 and PFSPE = 0

D: PFSDEL = 1 and PFSPE = 1

?: Don't care

5-6718 (F)

Figure 17. GCI-NT Timing Diagram

10 GCI+ Interface Module (continued)

10.3 GCI-NT Mode (GCCF[GMODE(1:0)] = 00) (continued)

10.3.1 GCI-SCIT Mode (GCCF, GMODE[1:0] = 01)

Figure 18 shows the frame structure for GCI-SCIT (Special Circuit Interface-T) mode, also known as GCI-TE mode. In this mode, the DCL clock rate is automatically set to 1536 kHz, overriding the value defined by GCCF[GRATE]. In addition, a powerdown mode is available in which DCL is stopped (see Section 10.5, GCI+ Powerdown Mode).

The data rate in GCI-SCIT mode is automatically set to 768 kHz, ignoring the value defined by GCCF[CKMODE]. A total of twelve 8-bit time slots are contained in each frame comprising three GCI channels of four time slots each. Time slots 0 and 1 carry user data, time slot 2 is the GCI monitor (MON) channel, and time slot 3 is the GCI signaling and control channel.

The FS1 output pin provides the frame synchronization clock (FSC) as defined by the GCI standard. It becomes active with the rising edge of DCL at the start of time slot 0 and is turned off one-half of a DCL period prior to the start of time slot 1.

In this mode, the NTN device:

- May transfer upstream/downstream data on time slots 0 (B1), 1 (B2), 4 (IC1), and 5 (IC2).

- Does not provide control over MON-0 (time slot 2) because layer-1 transceiver control is done through the internal microcontroller bus. The downstream monitor code will be FFh. Downstream A and E bits for GCI channel 0 will be set to 1. Upstream data in time slot 2 will be ignored.
- Does not support external layer-2 devices. This implies:
 - No data transfer is provided over GCI-D channel (time slot 3, first and second data bits) as the internal HDLC controller and microcontroller provide this service. Downstream data during these 2 bits will be set to 1.
 - There is no need to support GCI subchannel C/I control on channel 0 (C/I-0). The downstream C/I code will be Fh. The upstream C/I code will be ignored.
 - There is no need for terminal IC (TIC) subchannel control. The downstream TIC code will be Fh. The upstream TIC code will be ignored.
- Automatically manages the MON-1 channel's operation, maintenance, and data transfer (see Section 10.3.2, Monitor Message Transfer, for more details).
- Provides control of the C/I-1 subchannel (see Section 10.4, C/I Message Transfer, for more details).

Register GCOF1[OFF1(4:0)] controls the time slots to which PFS1 and PFS2 are assigned. Table 79 illustrates the relationship between the value of GCOF1[OFF1(4:0)] and the time-slot assignment of the PFS1 and PFS2 signals. Note that the GCOF2 register is ignored in GCI-NT mode.

10 GCI+ Interface Module (continued)

10.3 GCI-NT Mode (GCCF[GMODE[1:0]] = 00) (continued)

10.3.1 GCI-SCIT Mode (GCCF, GMODE[1:0] = 01) (continued)

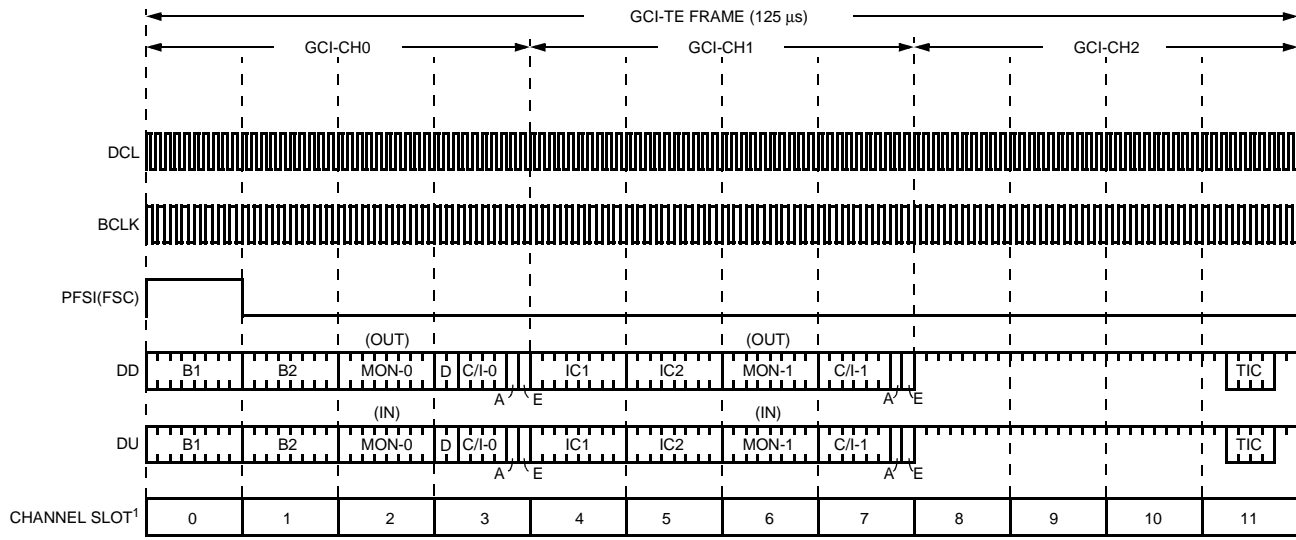

5-6723 (F)

1. Not output. Shown only for reference.

Notes:
GCCF[GMODE] = 01 (GCI-TE) ≥ DCL = 1536 kHz.
Data rate = 768 kHz.

Figure 18. GCI-TE Mode Frame Structure

Table 79. GCI-TE Data-Slot Association

GCOF1[OFF1(4:0)]	PFS1 Time Slot	PFS2 Time Slot
X0000	0	1
X0001	1	0
X0010	0	4
X0011	4	0
X0100	0	5
X0101	5	0
X0110	1	4
X0111	4	1
X1000	1	5
X1001	5	1
X1010	4	5
X1011	5	4
X11X0	0	1
X11X1	1	0

10 GCI+ Interface Module (continued)

10.3 GCI-NT Mode (GCCF[GMODE(1:0)] = 00) (continued)

10.3.2 Monitor Message Transfer

For both GCI-NT and GCI-TE modes, the NTN manages the monitor channel (MON) protocol as defined by the GCI standard. In GCI-NT mode, monitor data transfer occurs in time slot 2 (MON-0) using the A&E bit pair in time slot 3. In GCI-TE mode, monitor data transfer occurs in time slot 6 (MON-1) using the A&E bit pair in time slot 7.

Monitor messages may be one or more bytes in length. To transmit a single byte message downstream, the microcontroller writes the monitor byte into the GCDML register. Once this byte is internally loaded, the GCI controller asserts the interrupt bit GCIR[DMRDY] indicating to the microcontroller that it is ready to accept a new message to be transmitted. If the transmission is successfully completed, the GCI controller asserts interrupt bit GCIR[DMEOM]. Otherwise, if the transmission has been aborted, it will assert interrupt bit GCIR[DMABRT]. Downstream monitor message aborts may occur as a consequence of an abort request by the downstream device or an expiration of the GCI controller downstream timer (if GCOF1[GTMODE] = 1).

Multibyte monitor messages operate in a similar manner to single-byte messages, except that for an N-byte message, bytes 1 to N - 1 are written into register GCDMD, and the last monitor byte is written into register GCDML. The interrupt bit GCIR[DMRDY] is used in both cases to signify when new downstream data may be written to either GCDMD or GCDML.

Upstream monitor bytes, when confirmed, are transferred to the GCUMD register. Interrupt bit GCIR[UMRDY] is asserted to indicate a new monitor byte has been successfully received. At the completion of an upstream message, interrupt bit GCIR[UMEOM] is asserted. If the upstream message is aborted, the interrupt bit GCIR [UMABRT] is asserted. Upstream monitor message aborts may occur as a consequence of an implicit abort produced by an invalid upstream A&E bit pair sequence (normally produced by the downstream device) or an expiration of the GCI controller upstream timer (if GCOF1[GTMODE] = 1).

The embedded GCI controller has one timer associated with each monitor direction to avoid deadlock situations. Both timers may be enabled by setting

GCOF1[GTMODE] = 1. The downstream timer will be started each time the transfer of a downstream monitor byte is initiated. If the byte is not acknowledged within four frames, the timer will expire and generate an abort request. The upstream timer will be started upon the detection of a new byte. If this byte is not confirmed by the far end (because it did not detect identical bytes in two consecutive frames—upstream RNR event) or the byte cannot be transferred to the GCUMD register (because the microcontroller has not yet read the previous byte—upstream RNR event), the timer will expire.

10.4 C/I Message Transfer

For both GCI-NT and GCI-TE modes, the NTN manages data transfer over the command/indication channel as defined by the GCI standard. In GCI-NT mode, C/I data transfer occurs in the first 6 bits of time slot 3 (C/I-0). In GCI-TE mode, C/I data transfer occurs in the first 6 bits of time slot 7 (C/I-1).

To transmit a downstream C/I code, the microcontroller writes the code into the GCDCI register. This code will be continuously transmitted until a new code is written to GCDCI. The internal GCI controller will not read the new code from GCDCI until the current code has been transferred in at least two consecutive frames.

Upstream command/indication codes are first filtered before they are transferred to the GCUCI register. A double last look criterion is used to validate a new C/I code, i.e., a new code is transferred to the GCUCI register only if it is different from the previously loaded value and is received in two consecutive GCI frames. Whenever this happens, the GCIR[UCIC] interrupt is asserted.

10.5 GCI+ Powerdown Mode

The GCI+ may be placed in a powerdown mode by setting GCCF[GRATE(1:0)] = 00. Prior to enabling powerdown mode, the user must set DFR[PFS1_ACT] = 0 and DFR[PFS2_ACT] = 0. While in powerdown mode, the DCL clock signal is stopped (held low), the PFS1 and PFS2 signals are held low, and the DD signal is 3-stated.

When in powerdown, a falling edge on the DU signal causes an assertion of the interrupt bit GCIR[GWUP]. This allows the user to write a powerup routine for the GCI+ interface.

10 GCI+ Interface Module (continued)

10.6 GCI+ Loopbacks

DFR (G_L_LBK) and DFR (G_R_LBK) register bits control the loopback mode of the GCI interface.

When the DFR (G_L_LBK) register bit is set, downstream B1/B2 channel is fed back to the upstream B1/B2 channel.

When the DFR (G_R_LBK) register bit is set, upstream B1/B2 channel is fed back to the downstream B1/B2 channel.

Both loopbacks may be set at the same time. Loopbacks are transparent, except in the case when both are active at the same time. Note that loopbacks only operate over data channels; no other channels will be looped back.

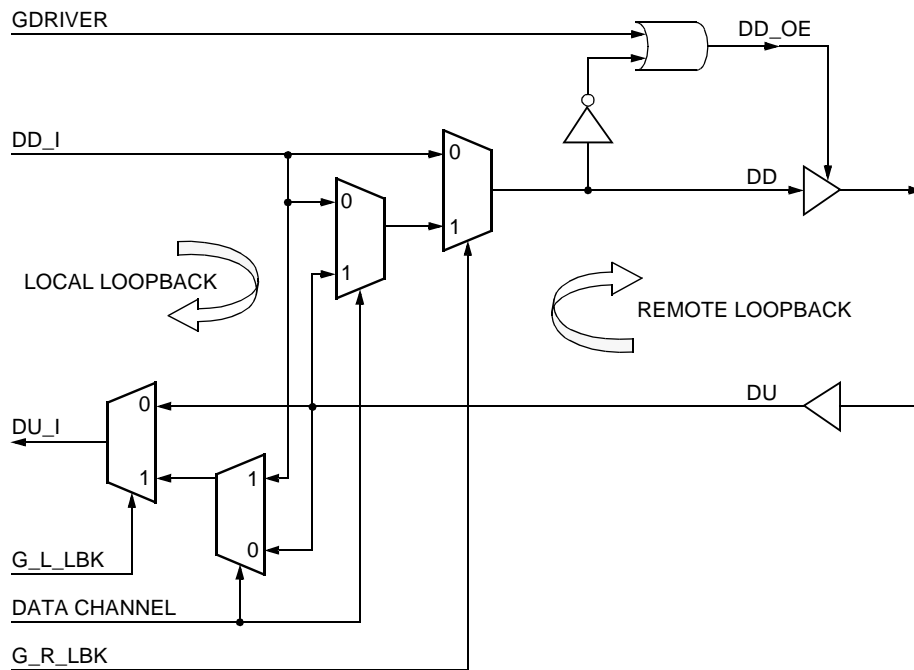

5-6724 (F)

Figure 19. GCI Loopback Logic

10 GCI+ Interface Module (continued)

10.7 GCI+ Register Set

Table 80. GCCF: GCI+ Configuration Register (0x2E)

Reg	R/W	Bit 7	Bit 6	Bit 5	Bit 4	Bit 3	Bit 2	Bit 1	Bit 0
GCCF	R/W	GDRIVER	PFSDEL	PFSPE	CKMODE	GRATE1	GRATE0	GMODE1	GMODE0
RESET	Default	0	0	0	0	0	0	0	0

Bit #	Symbol	Name/Description
7	GDRIVER	GCI+ Driver Type. Sets the type of output driver to be used for the GCI+ signal DD. 0: Open-drain driver. 1: Push-pull driver.
6	PFSDEL	PFS Delay. Sets the relative delay between PFSx (x = 1 or x = 2) and the first data bit of the time slot associated with PFSx. 0: PFSx rising edge is coincident with the start of the corresponding time slot. 1: PFSx rising edge occurs one bit time before the start of the corresponding time slot.
5	PFSPE	PFS Pulse (Short Frame Sync) or Envelope (Long Frame Sync) Mode. Sets the duration of the PFSx (x = 1 or x = 2) pulse. 0: PFS is an 8-bit envelope lasting from one time slot minus one-half of a DCL period. 1: PFS lasts for one data bit time.
4	CKMODE	GCI+ Data Clock Mode. Sets the clock mode of the GCI+ DCL clock to single or double clock mode when in TDM mode. This bit is ignored in GCI mode. 0: DCL set to double clock mode (two clocks per data bit). 1: DCL set to single clock mode (one clock per data bit).
3—2	GRATE[1:0]	GCI+ Clock Rate. Sets the DCL clock rate when in TDM mode. In GCI mode (GMODE[1:0] = 0x), these bits are ignored, unless they are equal to 00. 00: Clock disabled. 01: 512 kHz. 10: 1.536 MHz. 11: 2.048 MHz.
1—0	GMODE[1:0]	GCI+ Operation Mode. Sets the mode of operation of the GCI+ Interface. When in either of the GCI modes (GMODE[1:0] = 0x), these bits override the GRATE[1:0] values, unless GRATE[1:0] = 00. 00: GCI-NT mode. 01: GCI-TE mode. 1x: TDM mode.

10 GCI+ Interface Module (continued)

10.7 GCI+ Register Set (continued)

Table 81. GCOF1: GCI PFS1 Offset Select (0x2F)

Reg	R/W	Bit 7	Bit 6	Bit 5	Bit 4	Bit 3	Bit 2	Bit 1	Bit 0
GCOF1	R/W	GTMODE	G_R_LBK	G_L_LBK	OFF14	OFF13	OFF12	OFF11	OFF10
RESET	Default	0	0	0	0	0	0	0	0

Bit #	Symbol	Name/Description
7	GTMODE	GCI Time-Out Mode. (Only Applicable on GCI-NT and GCI-TE Operation Modes.) Enables the GCI time-out mechanism. 0: Time-out mechanism disabled. 1: Time-out mechanism enabled (abort after three TNR or RNRs), (0.5 ms since the beginning of transmission).
6	G_R_LBK	GCI Remote Loopback. 0: Normal operation. 1: Upstream B1- and B2-channel data on the GCI is internally looped back to the downstream GCI. Loopback is transparent, except when G_L_LBK is asserted at the same time.
5	G_L_LBK	GCI Local Loopback. 0: Normal operation. 1: Downstream B1- and B2-channel data on the GCI is internally looped back to the upstream GCI. Loopback is transparent, except when G_R_LBK is asserted at the same time.
4—0	OFF1[4:0]	Offset of PS1. Determines the number of channel slots by which PFS1 (B1 channel) is offset from the first time slot of the frame.

Table 82. GCOF2: GCI PFS2 Offset Select (0x30)

Reg	R/W	Bit 7	Bit 6	Bit 5	Bit 4	Bit 3	Bit 2	Bit 1	Bit 0
GCOF2	R/W	U_FORCE_B2DN	U_FORCE_B1DN	—	OFF24	OFF23	OFF22	OFF21	OFF20
RESET	Default	0	0	0	0	0	0	0	0

Bit #	Symbol	Name/Description
7	U_FORCE_B2DN	Microcontroller Access to Downstream B2 Channel. When this bit is set, the microcontroller can access the downstream B2-channel data from the U-interface to the GCI via the register B2DN (0x54) assuming that DFR[B2_SEL] = 1 and ECR0[LB2] = 0.
6	U_FORCE_B1DN	Microcontroller Access to Downstream B1 Channel. When this bit is set, the microcontroller can access the downstream B1-channel data from the U-interface to the GCI via the register B1DN (0x53) assuming that DFR[B1_SEL] = 1 and ECR0[LB1] = 0.
5	—	Reserved. Program to 0.
4—0	OFF2[4:0]	OFFSET of PFS2. Determines the number of time slots by which PFS2 (B2-channel) is offset from the first time slot of the frame.

10 GCI+ Interface Module (continued)

10.7 GCI+ Register Set (continued)

The following registers are only relevant in GCI mode, with the exception of GCIR[GWUP] and GCIE[GWUPE].

Table 83. GCDMD: GCI Downstream (Transmit) Monitor Data (0x31)

Reg	R/W	Bit 7	Bit 6	Bit 5	Bit 4	Bit 3	Bit 2	Bit 1	Bit 0
GCDMD	W	DMD7	DMD6	DMD5	DMD4	DMD3	DMD2	DMD1	DMD0
RESET	Default	1	1	1	1	1	1	1	1

Bit #	Symbol	Name/Description
7—0	DMD[7:0]	Downstream Monitor Data. For any multibyte monitor message, all message bytes except the last one are written to this register for transmission on the downstream monitor channel (see Section 10.3.2, Monitor Message Transfer). The DMRDY interrupt bit provides an indication that a new byte may be loaded.

Table 84. GCDML: GCI Downstream (Transmit) Monitor Data Last (0x32)

Reg	R/W	Bit 7	Bit 6	Bit 5	Bit 4	Bit 3	Bit 2	Bit 1	Bit 0
GCDML	W	DML7	DML6	DML5	DML4	DML3	DML2	DML1	DML0
RESET	Default	1	1	1	1	1	1	1	1

Bit #	Symbol	Name/Description
7—0	DML[7:0]	Downstream Monitor Last. The last byte of a downstream monitor message is written to this register for transmission on downstream monitor channel (see Section 10.3.2, Monitor Message Transfer). The DMRDY interrupt bit provides an indication that a new byte may be loaded.

Table 85. GCUMD: GCI Upstream (Receive) Monitor Data (0x33)

Reg	R/W	Bit 7	Bit 6	Bit 5	Bit 4	Bit 3	Bit 2	Bit 1	Bit 0
GCUMD	W	UMD7	UMD6	UMD5	UMD4	UMD3	UMD2	UMD1	UMD0
RESET	Default	—	—	—	—	—	—	—	—

Bit #	Symbol	Name/Description
7—0	UMD[7:0]	Upstream Monitor Channel Received Data. The most recent successfully received byte of an upstream monitor message is made available in this register (see Section 10.3.2, Monitor Message Transfer). The UMRDY interrupt bit provides an indication that a new byte has been received.

10 GCI+ Interface Module (continued)

10.7 GCI+ Register Set (continued)

Table 86. GCDCI: GCI Downstream (Transmit) C/I Data (0x34)

Reg	R/W	Bit 7	Bit 6	Bit 5	Bit 4	Bit 3	Bit 2	Bit 1	Bit 0
GCDCI	R/W	—	—	DCI6	DCI5	DCI4	DCI3	DCI2	DCI1
RESET	Default	0	0	—	—	—	—	—	—

Bit #	Symbol	Name/Description
7—6	—	Reserved. Program to 0.
5—0	DCI[6:1]	Downstream Command/Indication Code. The microcontroller writes the desired downstream (transmit) C/I code to this register. The code will be continuously transmitted until a new code is written. The internal GCI controller will not read the new code from the GCDCI until the current code has been transferred in at least two consecutive frames (see Section 10.4, C/I Message Transfer).

Table 87. GCUCI: GCI Upstream (Receive) C/I Data (0x35)

Reg	R/W	Bit 7	Bit 6	Bit 5	Bit 4	Bit 3	Bit 2	Bit 1	Bit 0
GCUCI	R/W	—	—	UCI6	UCI5	UCI4	UCI3	UCI2	UCI1
RESET	Default	0	0	—	—	—	—	—	—

Bit #	Symbol	Name/Description
7—6	—	Reserved. Program to 0.
5—0	UCI[6:1]	Upstream Command/Indication Code. Validated upstream (receive) C/I codes are stored here. The validation circuit employs a double last look criterion, i.e., a new code is transferred to the GCUCI register only if it is different from the previously loaded value and is received in two consecutive GCI frames. The UCIC interrupt bit provides an indication that a new validated byte has been received.

10 GCI+ Interface Module (continued)

10.7 GCI+ Register Set (continued)

Table 88. GCIR: GCI Interrupt Register (0x36)

Reg	R/W	Bit 7	Bit 6	Bit 5	Bit 4	Bit 3	Bit 2	Bit 1	Bit 0
GCIR	R	GWUP	UCIC	UMRDY	UMEOM	UMABRT	DMRDY	DMEOM	DMABRT
RESET	Default	0	0	0	0	0	0	0	0

Note: All bits in this register are set to 1 upon occurrence of the corresponding interrupt condition, and are cleared to 0 when the register is read.

Bit #	Symbol	Name/Description
7	GWUP	GCI Wake-Up Interrupt. This interrupt occurs when the following two conditions are true: 1. GCI clocks are stopped (GCCF[GRATE(1:0)] = 00). 2. A falling edge of DU occurs.
6	UCIC	Upstream Command/Indication Change. This interrupt occurs upon the reception of a new, validated C/I code in register GCUCI. At reset, the internal C/I code is set to 111111.
5	UMRDY	Upstream Monitor Byte Ready. This interrupt occurs when a newly received monitor byte is available in register GCUMD.
4	UMEOM	Upstream Monitor End of Message. This interrupt occurs when the last byte of a monitor message has been successfully received.
3	UMABRT	Upstream Monitor Aborted. This interrupt occurs when an abort has been detected in the received monitor message.
2	DMRDY	Downstream Monitor Ready. This interrupt occurs to indicate that the downstream monitor buffer is empty and a new byte may be loaded into GCDMD or GCDML.
1	DMEOM	Downstream End of Message. This interrupt occurs when the far end acknowledges the successful reception of the last byte of a downstream message.
0	DMABRT	Downstream Monitor Aborted. This signal is asserted when, during the transmission of a downstream monitor message, a request to abort has been received from the downstream device.

10 GCI+ Interface Module (continued)

10.7 GCI+ Register Set (continued)

Table 89. GCIE: GCI Interrupt Enable (0x37)

Reg	R/W	Bit 7	Bit 6	Bit 5	Bit 4	Bit 3	Bit 2	Bit 1	Bit 0
GCIE	R	GWUPE	UCICE	UMRDYE	UMEOME	UMABRTE	DMRDYE	DMEOME	DMABRTE
RESET	Default	0	0	0	0	0	0	0	0

Bit #	Symbol	Name/Description
7	GWUPE	GCI Wake-Up Interrupt Enable. 0: Interrupt disabled. 1: Interrupt enabled.
6	UCICE	UCIC Interrupt Enable. 0: Interrupt disabled. 1: Interrupt enabled.
5	UMRDYE	UMRDY Interrupt Enable. 0: Interrupt disabled. 1: Interrupt enabled.
4	UMEOME	UMEOM Interrupt Enable. 0: Interrupt disabled. 1: Interrupt enabled.
3	UMABRTE	UMABRT Interrupt Enable. 0: Interrupt disabled. 1: Interrupt enabled.
2	DMRDYE	DMRDY Interrupt Enable. 0: Interrupt disabled. 1: Interrupt enabled.
1	DMEOME	DMEOM Interrupt Enable. 0: Interrupt disabled. 1: Interrupt enabled.
0	DMABRTE	DMABRT Interrupt Enable. 0: Interrupt disabled. 1: Interrupt enabled.

11 GPIO Ports

Three general-purpose input/output ports are available on the T9000 device with each port being 8 bits wide.

For any port, each signal may be individually configured as an input or as an output by proper programming of registers GPDIR[0:2]. On reset, all ports are configured as inputs.

All GPIO signals have a weak pull-up resistor of 100 k Ω (nominal value). Unneeded GPIO signals should be configured as inputs, and may be left unconnected. If connected on the board, it is recommended that they be tied to V_{DD} to avoid power consumption.

Registers GPD[0:2] contain the value on the GPIO pin. For GPIO pins configured as inputs, the microcontroller accesses the port value by reading its corresponding GPD register. For GPIO pins configured as outputs, the microcontroller writes the desired value into its corresponding GPD register.

GPIO0.[3:0] and GPIO1.[3:0] pins, when configured as inputs (see registers GPDIR0 and GPDIR1), may also be configured as level-activated or transition-activated external interrupt sources for the microcontroller (see registers GPPOL and GPLEI). Any of these eight external interrupt sources may be masked by proper programming of register GPIE. On module reset, all interrupts are disabled. GPIO interrupt register (GPIR) is cleared when read by the microcontroller.

GPIO0.[3:0] and GPIO1.[3:0] pins, when configured as inputs, present a Schmitt trigger buffer for better noise immunity.

GPAF0 and GPAF1 registers define alternate functional modes for some GPIO pins.

- GPAF0[GPAF0.(7:6)] register bits, when set, override GPDIR0 [DIR0.(7:6)] and configure GPIO0.[7:6] as the PWM 1 output.
- GPAF0[GPAF0.(5:4)] register bits, when set, override GPDIR0[DIR0.(5:4)] and configure GPIO0.[5:4] as PWM0 outputs.

- GPAF1[GPAF1.(7:5)] register bits, when set, override GPDIR1[DIR1.(7:5)] and configure GPIO1.[7:5] as input trigger sources for timers 2, 1, and 0 (for proper timer operation, the microcontroller should also configure the associated SFR register bit for each timer).
- GPAF1[GPAF2.3] register bit, when set, overrides the GPDIR2[DIR2.3] register bit and configures GPIO2.3 as a SYNCO output from the dc/dc module (see Section 13, dc/dc Control Generator).
- GPAF1[GPAF2.2] register bit, when set, overrides the GPDIR2[DIR2.2] register bit and configures GPIO2.2 as the reference frame sync clock (FSC) output as specified in Section 10, GCI+ Interface Module.
- GPAF1[GPAF2.1] register bit, when set, overrides the GPDIR2[DIR2.1] register bit and configures GPIO2.1 as the GCI bit clock (BCLK) output (as specified in Section 10, GCI+ Interface Module).
- GPAF1[GPRESET] provides a nonlatching software reset of the GPIO module. It has the same effect as a global reset or a global software reset.
- DOCR[LT_NT] register bit, when set, ignores GPDIR2[DIR2.6] and configures GPIO2.6 as the input for 8 kHz master transmit clock (MTC) signal.
- When the test pin (pin 43) is asserted, GPIO1.4 and GPIO2.7 change their functions to USSP_E and PTLB_S, respectively, as explained in Table 4.

All registers are read/write to allow read-modify-write operations by the microcontroller. Transition activated interrupt sources may be individually reset by writing a 1 to the associated bits of GPPOL register.

All GPIO port signals are TTL levels. Driving capability is 6 mA for GPIO2.0 signal and 1 mA for all others.

Figure 20 summarizes features available for all GPIO signals.

11 GPIO Ports (continued)

Note: Alternate pin functions, shown in parentheses (), are selected when the TEST pin is asserted.
Alternate pin functions, shown in brackets [], are selected when the corresponding register bits are set.

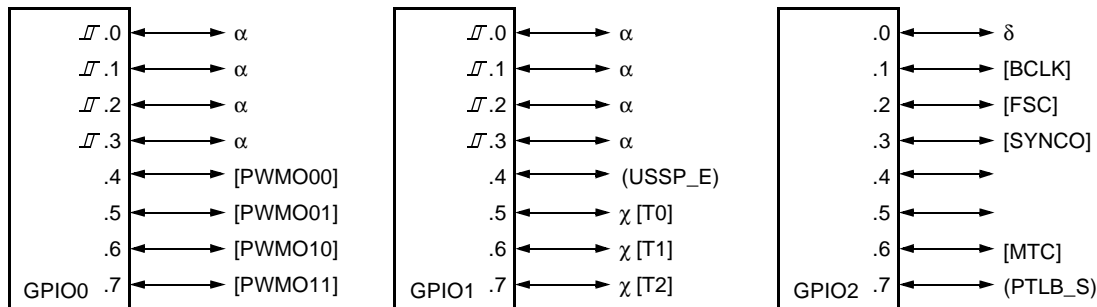

LEGEND:

- α : External interrupt capability.
- χ : Optional trigger sources for timers.
- δ : 6 mA sink capability.
- \mathcal{I} : Schmitt trigger when inputs.

5-6529F.c

Figure 20. GPIO Pin Capabilities Summary

11.1 GPIO Register Set

Table 90. GPDIR0: GPIO Port 0 Pin Direction (0x38)

Reg	R/W	Bit 7	Bit 6	Bit 5	Bit 4	Bit 3	Bit 2	Bit 1	Bit 0
GPDIR0	R/W	DIR0.7	DIR0.6	DIR0.5	DIR0.4	DIR0.3	DIR0.2	DIR0.1	DIR0.0
RESET	Default	1	1	1	1	1	1	1	1

Bit #	Symbol	Name/Description
7—0	DIR0.[7:0]	<p>GPIO0.[7:0] Pin Direction.</p> <p>0: Output. 1: Input.</p> <p>Note: When any of bits 7:4 in register GPAF0 are set, the corresponding DIR0.x value in this register is ignored and the pin function is determined according to the GPAF0 register function.</p>

11 GPIO Ports (continued)

11.1 GPIO Register Set (continued)

Table 91. GPDIR1: GPIO Port 1 Pin Direction (0x39)

Reg	R/W	Bit 7	Bit 6	Bit 5	Bit 4	Bit 3	Bit 2	Bit 1	Bit 0
GPDIR1	R/W	DIR1.7	DIR1.6	DIR1.5	DIR1.4	DIR1.3	DIR1.2	DIR1.1	DIR1.0
RESET	Default	1	1	1	1	1	1	1	1

Bit #	Symbol	Name/Description
7—0	DIR1.[7:0]	<p>GPIO1.[7:0] Pin Direction.</p> <p>0: Output. 1: Input.</p> <p>Note: When any of bits 7:5 in register GPAF1 are set, the corresponding DIR1.x value in this register is ignored and the pin function is determined according to the GPAF1 register function.</p>

Table 92. GPDIR2: GPIO Port 2 Pin Direction (0x3A)

Reg	R/W	Bit 7	Bit 6	Bit 5	Bit 4	Bit 3	Bit 2	Bit 1	Bit 0
GPDIR2	R/W	DIR2.7	DIR2.6	DIR2.5	DIR2.4	DIR2.3	DIR2.2	DIR2.1	DIR2.0
RESET	Default	1	1	1	1	1	1	1	1

Bit #	Symbol	Name/Description
7—0	DIR2.[7:0]	<p>GPIO2.[7:0] Pin Direction. DIR2.x defines the pin direction for GPIO2.x.</p> <p>0: Output. 1: Input.</p> <p>Notes: When any of bits 3:1 in register GPAF1 are set, the corresponding DIR2.x value in this register is ignored and the pin function is determined according to the GPAF1 register function.</p> <p>When DOCR[LT_NT] bit is set to 1 (NTN device is in LT mode), the DIR2.6 value is ignored and pin GPIO2.6 becomes an input to the 8 kHz MTC signal.</p>

11 GPIO Ports (continued)

11.1 GPIO Register Set (continued)

Table 93. GPAF0: GPIO Alternate Function Register #0 (0x3B)

Reg	R/W	Bit 7	Bit 6	Bit 5	Bit 4	Bit 3	Bit 2	Bit 1	Bit 0
GPAF0	R/W	GPAF0.7	GPAF0.6	GPAF0.5	GPAF0.4	—	—	—	—
RESET	Default	0	0	0	0	0	0	0	0

Bit #	Symbol	Name/Description
7	GPAF0.7	GPIO0.7 Alternate Function Selection. 0: No effect on device operation. 1: Overrides GPDIR[DIR0.7]. GPIO0.7 is configured as output #1 of the PWM module #1.
6	GPAF0.6	GPIO0.6 Alternate Function Selection. 0: No effect on device operation. 1: Overrides GPDIR0[DIR0.6]. GPIO0.6 is configured as output #0 of the PWM module #1.
5	GPAF0.5	GPIO0.5 Alternate Function Selection. 0: No effect on device operation. 1: Overrides GPDIR0[DIR0.5]. GPIO0.5 is configured as output #1 of the PWM module #0.
4	GPAF0.4	GPIO0.4 Alternate Function Selection. 0: No effect on device operation. 1: Overrides GPDIR0[DIR0.4]. GPIO0.4 is configured as output #0 of the PWM module #0.
3—0	—	Reserved. Program to 0.

11 GPIO Ports (continued)

11.1 GPIO Register Set (continued)

Table 94. GPAF1: GPIO Alternate Function Register #1 (0x3C)

Reg	R/W	Bit 7	Bit 6	Bit 5	Bit 4	Bit 3	Bit 2	Bit 1	Bit 0
GPAF1	R/W	GPAF1.7	GPAF1.6	GPAF1.5	—	GPAF2.3	GPAF2.2	GPAF2.1	GPRESET
RESET	Default	0	0	0	0	0	0	0	0

Bit #	Symbol	Name/Description
7	GPAF1.7	GPIO1.7 Alternate Function Selection. 0: No effect on device operation. 1: Overrides GPDIR1[DIR1.7] value. GPIO1.7 is configured as the timer 2 external input (connects directly to P1.0 of the microcontroller module).
6	GPAF1.6	GPIO1.6 Alternate Function Selection. 0: No effect on device operation. 1: Overrides GPDIR1[DIR1.6] value. GPIO1.6 is configured as the timer 1 external input (connects directly to P3.5 of the microcontroller module).
5	GPAF1.5	GPIO1.5 Alternate Function Selection. 0: No effect on device operation. 1: Overrides GPDIR1[DIR1.5] value. GPIO1.5 is configured as the timer 0 external input (connects directly to P3.4 of the microcontroller module).
4	—	Reserved. Program to 0.
3	GPAF2.3	GPIO2.3 Alternate Function Selection. 0: No effect on device operation. 1: Overrides GPDIR2[DIR2.3] value. GPIO2.3 is configured as the SYNCO output from the dc/dc module.
2	GPAF2.2	GPIO2.2 Alternate Function Selection. 0: No effect on device operation. 1: Overrides GPDIR2[DIR2.2] value. GPIO2.2 is configured as the FSC output from the GCI module.
1	GPAF2.1	GPIO2.1 Alternate Function Selection. 0: No effect on device operation. 1: Overrides GPDIR2[DIR2.1] value. GPIO2.1 is configured as the BCLK output from the GCI module.
0	GPRESET	GPIO Reset. Resets all the GPIO bits.

Table 95. GPD0: GPIO Port 0 Data Register (0x3D)

Reg	R/W	Bit 7	Bit 6	Bit 5	Bit 4	Bit 3	Bit 2	Bit 1	Bit 0
GPD0	R/W	GPD0.7	GPD0.6	GPD0.5	GPD0.4	GPD0.3	GPD0.2	GPD0.1	GPD0.0
RESET	Default	0	0	0	0	0	0	0	0

Bit #	Symbol	Name/Description
7—0	GPD0.[7:0]	I/O Data on GPIO Port 0.

11 GPIO Ports (continued)

11.1 GPIO Register Set (continued)

Table 96. GPD1: GPIO Port 1 Data Register (0x3E)

Reg	R/W	Bit 7	Bit 6	Bit 5	Bit 4	Bit 3	Bit 2	Bit 1	Bit 0
GPD1	R/W	GPD1.7	GPD1.6	GPD1.5	GPD1.4	GPD1.3	GPD1.2	GPD1.1	GPD1.0
RESET	Default	0	0	0	0	0	0	0	0

Bit #	Symbol	Name/Description
7—0	GPD1.[7:0]	I/O Data on GPIO Port 1.

Table 97. GPD2: GPIO Port 2 Data Register (0x3F)

Reg	R/W	Bit 7	Bit 6	Bit 5	Bit 4	Bit 3	Bit 2	Bit 1	Bit 0
GPD2	R/W	GPD2.7	GPD2.6	GPD2.5	GPD2.4	GPD2.3	GPD2.2	GPD2.1	GPD2.0
RESET	Default	0	0	0	0	0	0	0	0

Bit #	Symbol	Name/Description
7—0	GPD2.[7:0]	I/O Data on GPIO Port 2.

Table 98. GPLEI: GPIO Level-Edge-Triggered Interrupt Control (0x40)

Reg	R/W	Bit 7	Bit 6	Bit 5	Bit 4	Bit 3	Bit 2	Bit 1	Bit 0
GPLEI	R/W	ILE1.3	ILE1.2	ILE1.1	ILE1.0	ILE0.3	ILE0.2	ILE0.1	ILE0.0
RESET	Default	1	1	1	1	1	1	1	1

Bit #	Symbol	Name/Description
7—4	ILE1.[3:0]	Level/Edge Interrupt Control for GPIO1.[3:0]. Only applicable when pin is in input mode (see register GPD1R1). ILE1.x defines the interrupt mechanism for GPIO1.x pin. 0: Level-triggered. 1: Edge-triggered.
3—0	ILE0.[3:0]	Level/Transition Interrupt Control for GPIO0.[3:0]. Only applicable when pin is in input mode (see register GPD1R0). ILE0.x defines the interrupt mechanism for GPIO0.x. 0: Level-triggered. 1: Edge-triggered.

11 GPIO Ports (continued)

11.1 GPIO Register Set (continued)

Table 99. GPPOL: GPIO Interrupt Polarity Control (0x41)

Reg	R/W	Bit 7	Bit 6	Bit 5	Bit 4	Bit 3	Bit 2	Bit 1	Bit 0
GPPOL	R/W	IPOL1.3	IPOL1.2	IPOL1.1	IPOL1.0	IPOL0.3	IPOL0.2	IPOL0.1	IPOL0.0
RESET	Default	1	1	1	1	1	1	1	1

Bit #	Symbol	Name/Description
7—4	IPOL1.[3:0]	Interrupt Polarity for GPIO1.[3:0] Pins. Only applicable when pin is an input (see register GPDIR1). IPOL1.x specifies value of GPIO1.x that generates an interrupt. 0: Level-triggered => Interrupt when level is 0. Edge-triggered => Interrupt on falling edge. 1: Level-triggered => Interrupt when level is 1. Edge-triggered => Interrupt on rising edge.
3—0	IPOL0.[3:0]	Interrupt Polarity for GPIO0.[3:0] Pins. Only applicable when pin is an input (see register GPDIR0). IPOL0.x specifies value of GPIO0.x that generates an interrupt. 0: Level-triggered => Interrupt when level is 0. Edge-triggered => Interrupt on falling edge. 1: Level-triggered => Interrupt when level is 1. Edge-triggered => Interrupt on rising edge.

Table 100. GPIR: GPIO Interrupt Register (0x42)

Reg	R/W	Bit 7	Bit 6	Bit 5	Bit 4	Bit 3	Bit 2	Bit 1	Bit 0
GPIR	R/W	GPI1.3	GPI1.2	GPI1.1	GPI1.0	GPI0.3	GPI0.2	GPI0.1	GPI0.0
RESET	Default	—	—	—	—	—	—	—	—

Note: All bits in this register are set to 1 upon occurrence of the corresponding interrupt condition and are cleared to 0 when the register is read, except in level-triggering mode. When in level-triggering mode, this register is cleared when read only if the source of the interrupt has been taken away. They are also cleared upon writing a one to the corresponding bits in GPPOL registers.

Bit #	Symbol	Name/Description
7—4	GPIx.[3:0]	GPIO1.x Interrupt. This interrupt occurs when the appropriate edge or level, as determined by the GPLEI and GPPOL registers, has been sensed on the corresponding GPIO pin.
3—0	GPIx.[3:0]	GPIO0.x Interrupt. This interrupt occurs when the appropriate edge or level, as determined by the GPLEI and GPPOL registers, has been sensed on the corresponding GPIO pin.

11 GPIO Ports (continued)

11.1 GPIO Register Set (continued)

Table 101. GPIE: GPIO Interrupt Enable (0x43)

Reg	R/W	Bit 7	Bit 6	Bit 5	Bit 4	Bit 3	Bit 2	Bit 1	Bit 0
GPIE	R/W	GPIE13	GPIE12	GPIE11	GPIE10	GPIE03	GPIE02	GPIE01	GPIE00
RESET	Default	0	0	0	0	0	0	0	0

Bit #	Symbol	Name/Description
7—4	GPIE1.[3:0]	GPIO1.x Interrupt Enable. 0: Interrupt disabled. 1: Interrupt enabled.
3—0	GPIE0.[3:0]	GPIO0.x Interrupt Enable. 0: Interrupt disabled. 1: Interrupt enabled.

12 PWM Module

The PWM module is comprised of a general-purpose dual pulse-width modulator with sine modulation capability. Each module is capable of generating a sequence of pulses of programmable width and period. The generated pulses are centered in the programmed period. Figure 21 illustrates a general case of the PWM output signal for the two PWM generators. Normally, the pulse period is determined ahead of time and does not change during the pulse train generation. Pulse-width values change according to the user's desired algorithm.

In POTS applications, pulse-width modulated signals are typically used for generation of:

- Call alert signals (20 Hz to 30 Hz typical)
- Billing signals (50 Hz and 12 kHz typical)
- Answering machine control signals (2 kHz typical)
- Identification tones (697 Hz to 2 kHz)

In these applications, the width of the PWM signal is modulated according to the amplitude of a sine wave sampled at pulse period intervals. The PWM signal is then low-pass filtered with a simple RC integrator.

There are three configuration registers per PWM generator: PWxCF, PWxVH, and PWxVL, where $x = 0$ or 1 . In addition, there is a common PWM interrupt register (PWIR) shared by both generators. Both generators are identical, so references to these registers in the explanation that follows will simply use x in place of 0 or 1 in the register names.

Each PWM output can be made available on two separate GPIO pins according to the programming of register bits GPAF0.[7:4]. This allows the same PWMO to drive two different external devices by proper programming of register GPAF0.[7:4]. For example, the outputs of PWMO (PWMO00 and PWMO01) can drive two external devices and the outputs of PWM1 (PWMO10 and PWMO11) can also drive 2 different external devices.

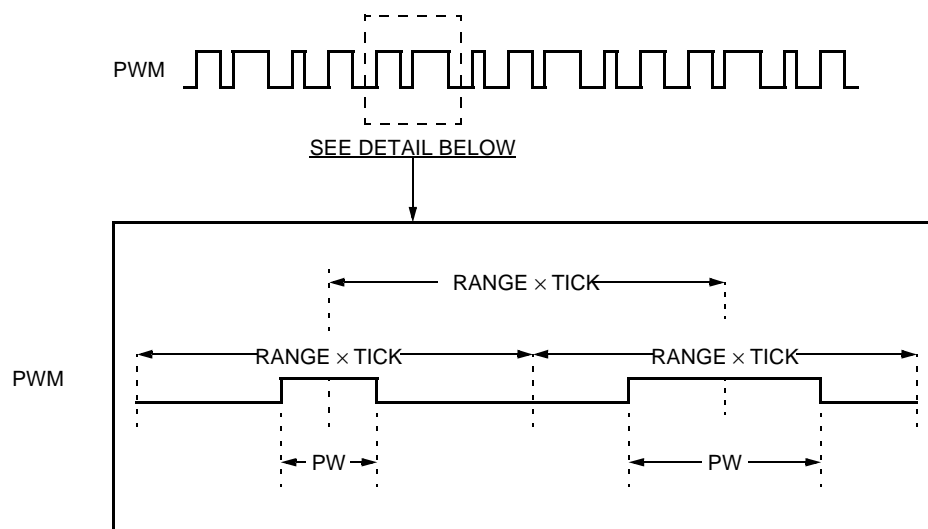

5-6522F

Figure 21. Pulse-Width Modulated Output Signal

12 PWM Module (continued)

For low-frequency tones (Hz range), the algorithm that defines the width of the pulse is easily accomplished with microcontroller routines (manual mode). However, implementing higher frequency tones (kHz range) requires a large degree of microcontroller intervention. To address this issue, the PWM generators were designed to operate in two different modes: manual/timer mode and auto mode.

12.1 PWM Manual/Timer Operation Mode

In manual mode, the user may implement any desired algorithm to define the width of the pulses. Two important parameters that are controlled via the PWxCF register are pulse-width granularity and pulse-width range. Pulse-width granularity defines the minimum duration (or tick) of a pulse width. Pulse-width range denotes the number of possible ticks in a pulse period or, in other words, the number of different width values with which the pulse can be modulated. The tick size and pulse period may be expressed as:

$$\text{Tick} = \text{Granularity} \times 65 \text{ ns} \quad (1)$$

$$\text{PP} = \text{Range} \times \text{Tick} = \text{Range} \times \text{Granularity} \times 65 \text{ ns} \quad (2)$$

Concerning the above relationships, note the following:

- A small granularity allows for a finer resolution of the resulting output signal in time, and therefore requires less filtering.
- A large range allows for a finer resolution, in amplitude, of the resulting output signal.
- Power consumption is roughly inversely proportional to the granularity value, so the larger the granularity, the less power the circuit will consume.
- As granularity and range are increased, the equivalent oversampling rate is decreased (i.e., the pulse period, PP, increases as shown in equation 2 above).

At the start of a pulse period, the controller loads the value contained in register PWxVH and generates a pulse with a width PWxVH multiplied by the tick value (where only the appropriate MSBs of PWxVH are used according to the tick value, see register PWxVH). The value in PWxVL determines the rate at which the PWIR[PWxI] interrupt register bit will be asserted. The module asserts the PWIR (PWxI) interrupt register bit every PWxVL + 1 pulse period intervals. The interrupt is generated only if the PWxCF (PWxIE) bit is set. The interrupt is asserted even if GPIO pin is not assigned to the PWMx generator. The interrupt register is reset upon a register read operation.

12.2 PWM Auto Operation (Sine) Mode

The auto mode uses a sine modulator controller (PWSM) to substantially reduce the overhead requirement of the microcontroller. In this mode, the width of the pulses automatically follows the amplitude of a sine wave of frequency Fs. A 256-byte ROM is used to store discrete values of amplitude for one period of a sine wave, where each successive ROM location, n, represents the sine amplitude at a normalized time of $t = n/256$.

Figure 22 shows a simplified architecture of the PWM block (the shaded areas indicate the extra logic required for implementing the sine wave functionality). The 8-bit ROM address is derived from the upper 8 bits of the 16-bit accumulator output. The accumulator simply adds the 16-bit value formed by the PWxVH and PWxVL registers (PWV) to its output every cycle, where the cycle time is determined by the pulse period, PP. Consider then, how PWV and PP affect the output.

When PWV is $<2^8$, each ROM value will be output for a least one cycle, and possibly even more (depending on how far below 2^8 the PWV value is). Conversely, when PWV is $>2^8$, some ROM values will be skipped. Thus, as the value of PWV drops below 2^8 , it has the effect of increasing the quantization error in the amplitude of the sinewave output. PWV, then, can be thought of as controlling the ROM step size (where the step size can be <1).

When PP is large, the rate at which each newly formed ROM address is output is slower than when PP is small. Therefore, if all other factors are equal, a larger PP will result in a lower frequency sinewave output. PP, then, can be thought of as controlling the ROM step rate.

In auto mode, range and granularity take on a somewhat different meaning than in manual mode. In auto mode, Equations (1) and (2) still hold with respect to range and granularity, but tick does not play a direct role in this case. Rather, it is the combination of range and granularity that determines the frequency and amplitude resolution of the output waveform as explained above.

12 PWM Module (continued)

12.2 PWM Auto Operation (Sine) Mode (continued)

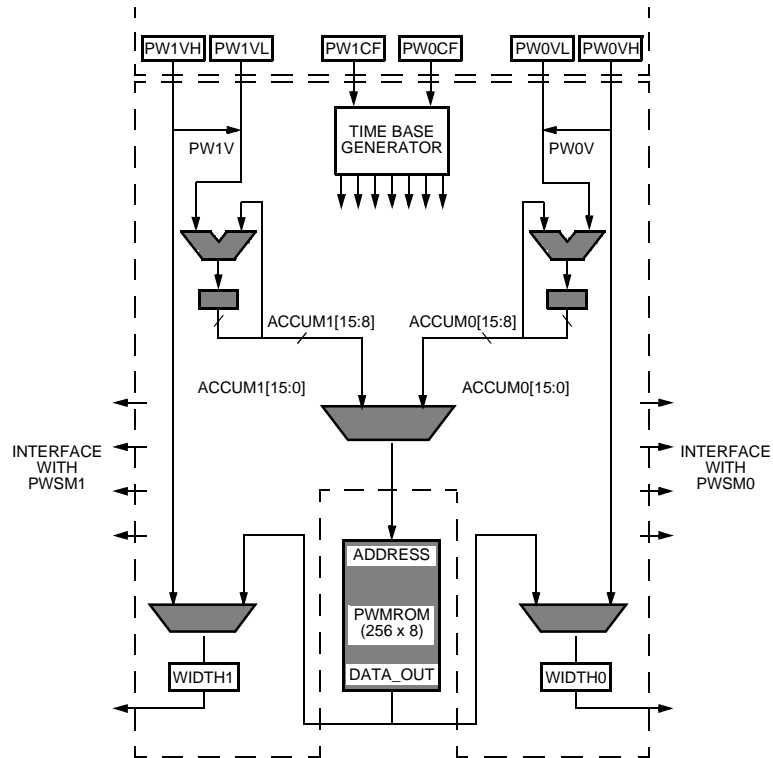

5-7204F

Figure 22. PWMCTRL Architecture

12 PWM Module (continued)

12.3 PWSM ROM

As mentioned previously, the ROM shown in Figure 22 is used to store the amplitude values of one complete cycle of a sine wave. The ROM address generated by the accumulator determines the current ROM output value. The sine amplitudes in the ROM represent a sine wave with a 2.5%—97.5% scale and a dc offset of 128 (out of 256). The values can be expressed by the following formula:

$$W(A) = \text{ROUND} (128 \times [1 + 0.95 \times \text{SIN} \{2 \times \pi \times A/256\}])$$

Table 102 illustrates the resulting value W(A) at each ROM address A.

Table 102. ROM Code

Values in decimal (A = address; W = width).

A	W	A	W	A	W	A	W	A	W	A	W	A	W	A	W
0	128	32	214	64	250	96	214	128	128	160	42	192	6	224	42
1	131	33	216	65	250	97	212	129	125	161	40	193	6	225	44
2	134	34	218	66	249	98	210	130	122	162	38	194	7	226	46
3	137	35	220	67	249	99	207	131	119	163	36	195	7	227	49
4	140	36	222	68	249	100	205	132	116	164	34	196	7	228	51
5	143	37	224	69	249	101	203	133	113	165	32	197	7	229	53
6	146	38	226	70	248	102	200	134	110	166	30	198	8	230	56
7	149	39	227	71	248	103	198	135	107	167	29	199	8	231	58
8	152	40	229	72	247	104	196	136	104	168	27	200	9	232	60
9	155	41	232	73	247	105	193	137	101	169	25	201	9	233	63
10	158	42	231	74	246	106	191	138	98	170	24	202	10	234	65
11	160	43	234	75	245	107	188	139	96	171	22	203	11	235	68
12	163	44	235	76	244	108	185	140	93	172	21	204	12	236	71
13	166	45	237	77	243	109	183	141	90	173	19	205	13	237	73
14	169	46	238	78	242	110	180	142	87	174	18	206	14	238	76
15	172	47	239	79	241	111	177	143	84	175	17	207	15	239	79
16	175	48	240	80	240	112	175	144	81	176	16	208	16	240	81
17	177	49	241	81	239	113	172	145	79	177	15	209	17	241	84
18	180	50	242	82	238	114	169	146	76	178	14	210	18	242	87
19	183	51	243	83	237	115	166	147	73	179	13	211	19	243	90
20	185	52	244	84	235	116	163	148	71	180	12	212	21	244	93
21	188	53	245	85	234	117	160	149	68	181	11	213	22	245	96
22	191	54	246	86	232	118	158	150	65	182	10	214	24	246	98
23	193	55	247	87	231	119	155	151	63	183	9	215	25	247	101
24	196	56	247	88	229	120	152	152	60	184	9	216	27	248	104
25	198	57	248	89	227	121	149	153	58	185	8	217	29	249	107
26	200	58	248	90	226	122	146	154	56	186	8	218	30	250	110
27	203	59	248	91	224	123	143	155	53	187	7	219	32	251	113
28	205	60	249	92	222	124	140	156	51	188	7	220	34	252	116
29	207	61	249	93	220	125	137	157	49	189	7	221	36	253	119
30	210	62	249	94	218	126	134	158	46	190	7	222	38	254	122
31	212	63	250	95	216	127	131	159	44	191	6	223	40	255	125

12 PWM Module (continued)

12.4 PWM Auto Mode Example

Consider an example of how to set up the PWM module in auto mode. Suppose we want to generate a sine wave of frequency F_s . First select the values of range and granularity, and then compute the appropriate value of $PW \times VH/L$. To accomplish this, the procedure is as follows:

Calculate the pulse period, PP, (from equation 2)

$$PP = \text{Range} \times \text{Granularity} \times 65 \text{ ns} \quad (3)$$

Calculate the sine period, SP:

$$SP = \frac{1}{F_s} \quad (4)$$

Based on PP and SP, we can calculate the number of samples (K_s) per sine period:

$$K_s = \frac{SP}{PP} = \frac{SP}{\text{Range} \times \text{Granularity} \times 65 \text{ ns}} \quad (5)$$

Now calculate the 16-bit quantity PWV (i.e., $PWV \times H/L$, the amount by which the accumulator will increment each time as shown in Figure 22). There are 2^{16} total addresses in one sine period, SP. Since there are K_s samples in one sine period, 2^{16} must be divided by K_s so that exactly one cycle of all 2^{16} addresses has been completed in one sine period, SP. The rounded result is PWV, which gets written into the $PW \times VH$ and $PW \times VL$ registers:

$$PWV = \text{ROUND} \left(\frac{2^{16}}{K_s} \right) = \text{ROUND} \left(\frac{2^{16} \times \text{Range} \times \text{Granularity} \times 65 \text{ ns}}{SP} \right) \quad (6)$$

Now, back-calculate the actual number of samples (K_a) based on the rounded result:

$$K_a = \frac{2^{16}}{PWV} \quad (7)$$

To find the error in frequency due to rounding, first back-calculate the actual frequency of the sine modulator output by taking the inverse of the pulse period times the actual number of samples, as follows:

$$F_a = \frac{1}{PP \times K_a} \quad (8)$$

Then calculate the error in frequency as:

$$F_{err} = \frac{F_a - F_s}{F_s} \times 100\% \quad (9)$$

To further understand the operation of the PWSM module, consider the math behind the operation. The sine wave being generated can be described by the following equation:

$$f(t) = A \sin(2\pi \times F_a \times t) \quad (10)$$

where F_a is computed per equation 8. A new value for this equation is computed every pulse period, PP. Therefore, in the n th pulse period (where n is an integer representing the current sample number, beginning with sample 0), the time (t) in the above equation is:

$$t = n \times PP \quad (11)$$

Substituting equation 11 into equation 10 yields:

$$f(t) = A \sin(2\pi \times F_a \times n \times PP) \quad (12)$$

Now rearranging equation 8,

$$PP = \frac{1}{F_a \times K_a} \quad (13)$$

and substituting the value of K_a computed in equation 7 results in:

$$PP = \frac{PWV}{F_a \times 2^{16}} \quad (14)$$

Substituting equation 14 into equation 12 yields:

$$f(t) = A \sin\left(2\pi \frac{n \times PWV}{2^{16}}\right) \quad (15)$$

From equation 15, it is evident that the argument generated sine wave is $n \times PWV$. This term is generated at the output of the accumulator shown in Figure 22 by clocking the accumulator at PP intervals. The maximum value of $n \times PWV$ is 2^{16} because the accumulator will roll over after it reaches 2^{16} . Therefore, the factor of 2^{16} in the denominator is the normalization factor, which is equal to the maximum value of $n \times PWM$.

12 PWM Module (continued)

12.4 PWM Auto Mode Example (continued)

In the physical circuit implementation, the width of the pulse follows a 2.5%—97.5% modulation scheme and depends on the granularity and tick values as described in the following equation:

$$W(n) = \text{FLOOR} \left(\frac{\text{ROUND} \left(128 \times \left(1 + 0.95 \times \sin \left(2\pi \times \frac{n \times \text{PWV}}{2^{16}} \right) \right) \right)}{\text{Granularity}} \right) \times \text{tick} \quad (16)$$

Note that, in step 1 of the above procedure (equation 3), it is assumed that range and granularity have already been chosen. It is useful to look at the effects of selecting different values for range and granularity in order to guide the selection of these values for a particular application. Consider an example using real numbers.

Suppose it is desired to generate a sine wave of frequency $F_s = 697$ Hz. Table 103 shows the resulting values of PWV, K_a , F_a , and frequency error (F_{err}) for all possible values of range and granularity.

Table 103. PWM Sine Modulator Programming Example

Granularity	Range	PP (μ s)	K_s ($F_s = 697$)	PWV	K_a	F_a	F_{err} (%)
1	32	2.08	688.666	95	689.85	695.80	0.17
1	64	4.17	344.333	190	344.93	695.80	0.17
1	128	8.33	172.166	381	172.01	697.63	-0.09
1	256	16.67	86.083	761	86.12	696.72	0.04
2	32	4.17	344.333	190	344.93	695.80	0.17
2	64	8.33	172.166	381	172.01	697.63	-0.09
2	128	16.67	86.083	761	86.12	696.72	0.04
2	256	33.33	43.042	1523	43.03	697.17	-0.02
4	32	8.33	172.166	381	172.01	697.63	-0.09
4	64	16.67	86.083	761	86.12	696.72	0.04
4	128	33.33	43.042	1523	43.03	697.17	-0.02
4	256	66.67	21.521	3045	21.52	696.95	0.01
8	32	16.67	86.083	761	86.12	696.72	0.04
8	64	33.33	43.042	1523	43.03	697.17	-0.02
8	128	66.67	21.521	3045	21.52	696.95	0.01
8	256	133.33	10.760	6090	10.76	696.95	0.01
16	32	33.33	43.042	1523	43.03	697.17	-0.02
16	64	66.67	21.521	3045	21.52	696.95	0.01
16	128	133.33	10.760	6090	10.76	696.95	0.01
16	256	266.67	5.380	12181	5.38	697.00	0.00

One interesting result in Table 103 is that, for different combinations of granularity (G) and range (R) whose products are equal, the resulting parameters for the sine wave output in each case are identical. For example, the pairs (G = 1, R = 256), (G = 2, R = 128), (G = 4, R = 64), and (G = 8, R = 32) all yield identical values of PWV, K_a , F_a , and F_{err} . However, note from equation 16 that larger values of granularity will produce more rounding error for a given $W(n)$.

12 PWM Module (continued)

12.4 PWM Auto Mode Example (continued)

As mentioned earlier, when PWV is greater than 2^8 , some ROM values will be skipped. Another way of stating this is that, when K_a is less than 2^8 , some ROM values will be skipped. This is true by definition, since K_a represents the number of samples output during one period of a sine wave, and there are 2^8 ROM samples. If one criterion of the generated sine wave is that the amplitude be as accurate as possible (i.e., no ROM values are skipped), then the choice of entries in Table 103 is limited to those with values of K_a that are greater than or equal to 256. Note that only three of the entries meet this requirement in this example.

This example is provided to illustrate some of the considerations when selecting values for range and granularity. It may be useful to construct a spreadsheet that reproduces Table 103 (which itself was generated using a spreadsheet) for the frequency value of interest. Other engineering trade-offs, such as low-pass filter complexity vs. PWM output accuracy, are beyond the scope of this document but may be important to consider depending on the specific system requirements.

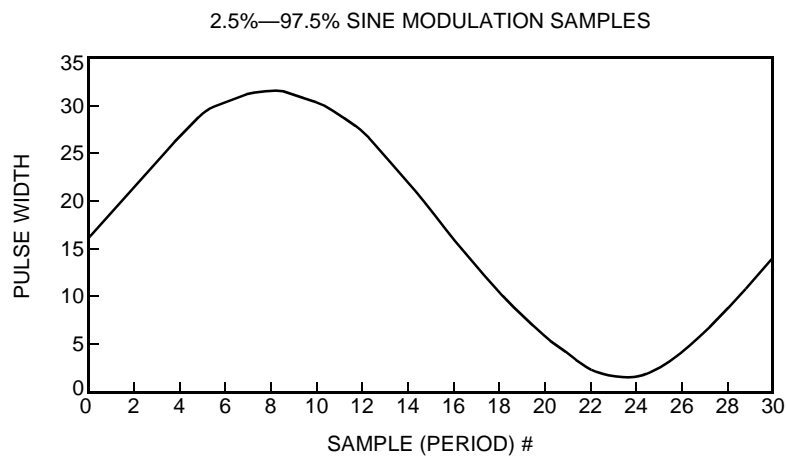

5-6524F

Figure 23. Widths of PWM Pulses Generated with a 2.5%—97.5% Modulation Width

12 PWM Module (continued)

12.5 PWM Powerdown Mode

Each PWM generator can be powered down by setting PWxCF (PwxE) register bit to 0.

12.6 PWM Module Register Set

Table 104. PW0CF: Pulse-Width Modulator 0 Configuration (0x44)

Reg	R/W	Bit 7	Bit 6	Bit 5	Bit 4	Bit 3	Bit 2	Bit 1	Bit 0
PW0CF	R/W	PW0_E	PW0AUTO	PW0IE	PW0G.2	PW0G.1	PW0G.0	PW0R.1	PW0R.0
RESET	Default	0	—	0	—	—	—	—	—

Bit #	Symbol	Name/Description
7	PW0_E	<p>PWM 0 Enable.</p> <p>0: Powerdown mode. PWMO0 output is maintained at 0. 1: Pulse-width modulator enabled. In a normal operation, this register should be set after defining PP0.</p>
6	PW0AUTO	<p>PWM 0 Auto/Manual Operation Mode.</p> <p>0: Manual/timer operation mode. 1: Sine modulator activated.</p>
5	PW0IE	<p>PWM 0 Interrupt Enable.</p> <p>0: Interrupt disabled. 1: Interrupt enabled.</p>
4—2	PW0G.[2:0]	<p>PWM 0 Granularity. This parameter defines the granularity of the output pulse; i.e., the minimum pulse width at high (tick0). Pulse period and pulse width are multiples of the tick0 value (see pulse-width range below).</p> <p>000: Granularity = 1 tick0 = 65 ns. 001: Granularity = 2 tick0 = 130 ns. 010: Granularity = 4 tick0 = 260 ns. 011: Granularity = 8 tick0 = 521 ns. 1XX: Granularity = 16 tick0 = 1042 ns.</p>
1—0	PW0R.[1:0]	<p>PWM 0 Range. This parameter defines the number of different values the pulse width can take. Pulse period (PP0) is a function of the pulse-width granularity and the pulse-width range, as follows:</p> <p>00: Range = 32 PP0 = 32 * tick ns. 01: Range = 64 PP0 = 64 * tick ns. 10: Range = 128 PP0 = 128 * tick ns. 11: Range = 256 PP0 = 256 * tick ns.</p>

12 PWM Module (continued)

12.6 PWM Module Register Set (continued)

Table 105. PW0VH: Pulse-Width Modulator 0 Pulse-Width Value, High Byte (0x45)

Reg	R/W	Bit 7	Bit 6	Bit 5	Bit 4	Bit 3	Bit 2	Bit 1	Bit 0
PW0VH	R/W	PW0VH7	PW0VH6	PW0VH5	PW0VH4	PW0VH3	PW0VH2	PW0VH1	PW0VH0
RESET	Default	—	—	—	—	—	—	—	—

Bit #	Symbol	Name/Description
7—0	PW0VH[7:0]	<p>PWM 0 Pulse-Width Value, High Byte. When manual pulse-width control is programmed, the pulse-width high can be expressed as:</p> <p>PW0 = PW0VH[7:0] * tick when PW0R.[1:0] = 11. PW0 = PW0VH[7:1] * tick when PW0R.[1:0] = 10. PW0 = PW0VH[7:2] * tick when PW0R.[1:0] = 01. PW0 = PW0VH[7:3] * tick when PW0R.[1:0] = 00.</p> <p>If auto mode is selected, it contains the high-order byte of the programmed sine frequency (Fs).</p>

Table 106. PW0VL: Pulse-Width Modulator 0 Pulse-Width Value, Low Byte (0x46)

Reg	R/W	Bit 7	Bit 6	Bit 5	Bit 4	Bit 3	Bit 2	Bit 1	Bit 0
PW0VL	R/W	PW0VL7	PW0VL6	PW0VL5	PW0VL4	PW0VL3	PW0VL2	PW0VL1	PW0VL0
RESET	Default	—	—	—	—	—	—	—	—

Bit #	Symbol	Name/Description
7—0	PW0VL[7:0]	<p>PWM 0 Pulse-Width Value, Low Byte. Its function depends on the operation mode selected.</p> <p>When auto operation mode is selected (PW0CF[PW0AUTO] = 1), it contains the low-order byte of the programmed sine frequency (Fs).</p> <p>When manual/timer operation mode is selected (PW0CF[PW0AUTO] = 0), it defines the rate at which PWIR[PW0I] interrupt register bit will be asserted:</p> <p>PWIR[PW0I] assertion rate = PP0 x (PW0VL + 1).</p>

12 PWM Module (continued)

12.6 PWM Module Register Set (continued)

Table 107. PW1CF: Pulse-Width Modulator 1 Configuration (0x47)

Reg	R/W	Bit 7	Bit 6	Bit 5	Bit 4	Bit 3	Bit 2	Bit 1	Bit 0
PW1CF	R/W	PW1_E	PW1AUTO	PW1IE	PW1G.2	PW1G.1	PW1G.0	PW1R.1	PW1R.0
RESET	Default	0	—	0	—	—	—	—	—

Bit #	Symbol	Name/Description
7	PW1_E	PWM 1 Enable. 0: Powerdown mode. PWMO1 output is maintained at 0. 1: Pulse-width modulator enabled. In a normal operation, this register should be set after defining PP1 (see pulse-width range below).
6	PW1AUTO	PWM 1 Auto/Manual Operation Mode. 0: Manual programming. 1: Sine modulator activated.
5	PW1IE	PWM 1 Interrupt Enable. 0: Interrupt disabled. 1: Interrupt enabled.
4—2	PW1G.[2:0]	PWM 1 Granularity. This parameter defines the granularity of the output pulse; i.e., the minimum pulse width at high (tick1). Pulse period and pulse width are multiples of the tick1 value (see pulse-width range below). 000: Granularity = 1 tick1 = 65 ns. 001: Granularity = 2 tick1 = 130 ns. 010: Granularity = 4 tick1 = 260 ns. 011: Granularity = 8 tick1 = 521 ns. 1XX: Granularity = 16 tick1 = 1042 ns.
1—0	PW1R.[1:0]	PWM 1 Range. This parameter defines the number of different values the pulse width can take. Pulse period (PP1) is a function of the pulse width granularity and the pulse width range, as follows: 00: Range = 32 PP1 = 32 * tick1 ns. 01: Range = 64 PP1 = 64 * tick1 ns. 10: Range = 128 PP1 = 128 * tick1 ns. 11: Range = 256 PP1 = 256 * tick1 ns.

12 PWM Module (continued)

12.6 PWM Module Register Set (continued)

Table 108. PW1VH: Pulse-Width Modulator 1 Pulse-Width Value, High Byte (0x48)

Reg	R/W	Bit 7	Bit 6	Bit 5	Bit 4	Bit 3	Bit 2	Bit 1	Bit 0
PW1VH	R/W	PW1VH7	PW1VH6	PW1VH5	PW1VH4	PW1VH3	PW1VH2	PW1VH1	PW1VH0
RESET	Default	—	—	—	—	—	—	—	—

Bit #	Symbol	Name/Description
7—0	PW1VH[7:0]	<p>PWM 1 Pulse-Width Value, High Byte. When manual pulse-width control is programmed, the pulse-width high can be expressed as follows:</p> <p>PW1 = PW1VH[7:0] * tick when PW1R.[1:0] = 11. PW1 = PW1VH[7:1] * tick when PW1R.[1:0] = 10. PW1 = PW1VH[7:2] * tick when PW1R.[1:0] = 01. PW1 = PW1VH[7:3] * tick when PW1R.[1:0] = 00.</p> <p>If auto mode is selected, it contains the high-order byte of the programmed sine frequency (Fs).</p>

Table 109. PW1VL: Pulse-Width Modulator 1 Pulse-Width Value, Low Byte (0x49)

Reg	R/W	Bit 7	Bit 6	Bit 5	Bit 4	Bit 3	Bit 2	Bit 1	Bit 0
PW1VL	R/W	PW1VL7	PW1VL6	PW1VL5	PW1VL4	PW1VL3	PW1VL2	PW1VL1	PW1VL0
RESET	Default	—	—	—	—	—	—	—	—

Bit #	Symbol	Name/Description
7—0	PW1VL[7:0]	<p>PWM#1 Pulse-Width Value, Low Byte. Its function depends on the operation mode selected.</p> <p>When auto operation mode is selected (PW1CF[PW1AUTO] = 1), it contains the low-order byte of the programmed sine frequency (Fs).</p> <p>When manual/timer operation mode is selected (PW1CF[PW1AUTO] = 0), it defines the rate at which PWIR[PW1I] interrupt register bit will be asserted:</p> <p>PWIR[PW1I] assertion rate = PP1 x (PW1VL + 1).</p>

Table 110. PWIR: Pulse-Width Modulator Interrupt Register (0x4A)

Reg	R/W	Bit 7	Bit 6	Bit 5	Bit 4	Bit 3	Bit 2	Bit 1	Bit 0
PWIR	R	—	—	—	—	—	—	PW1I	PW0I
RESET	Default	—	—	—	—	—	—	0	0

Note: All bits in this register are set to 1 upon occurrence of the corresponding interrupt condition, and are cleared to 0 when the register is read.

Bit #	Symbol	Name/Description
7—2	—	Reserved.
1—0	PWxI	<p>PWM x Interrupt. This interrupt occurs only in manual/timer mode (PWxAUTO = 0). Once the current PWV value initiates the PWM output waveform, this interrupt is asserted to indicate to the microcontroller that it should load a new value within PPx * (PWxVL + 1) ns. If the microcontroller does not load a new value within this window, the previously loaded value will be used to generate the new pulse. PWxCF[PWxIE] is the enable bit for this interrupt.</p>

13 dc/dc Control Generator

This module generates a square wave signal (50% duty cycle) with a programmable period. The output frequency is controlled by register DCCF and ranges from 15 kHz to 480 kHz. It can be expressed by:

$$F_{dc/dc} = 960 / (2 * (DCV + 1)) \text{ kHz.}$$

As an example, DCV = 14 generates a 32 kHz square wave output signal.

This module can be disabled by setting DCCF[DC_E] to 0.

The output of this module, SYNCO, is available on pin GPIO2.3 when GPAF1[GPAF2.3] is set. If GPAF1[GPAF2.3] = 0, it is recommended that the dc/dc module be disabled to minimize power consumption (see DC_E bit in DCR0 register).

13.1 dc/dc Control Generator Register Set

Table 111. DCCF: dc/dc Configuration Register (0x4B)

Reg	R/W	Bit 7	Bit 6	Bit 5	Bit 4	Bit 3	Bit 2	Bit 1	Bit 0
DCCF	R/W	—	—	DC_E	DCV4	DCV3	DCV2	DCV1	DCV0
RESET	Default	0	0	0	—	—	—	—	—

Bit #	Symbol	Name/Description
7—6	—	Reserved. Program to 0.
5	DC_E	dc/dc Controller Enable. When disabled, SYNCO = 0. 0: Powerdown. 1: Enabled.
4—0	DCV[4:0]	dc Prescale Value. SYNCO Frequency = 960/(2 * (DCV + 1)) kHz.

DCCF may be read by the microcontroller, allowing a read-modify-write operation.

14 Comparators

The comparator module consists of three low-power, general-purpose comparators. Each comparator has an independent powerdown mode (CME register). Each comparator can generate a separate interrupt (CMIR[CMI(2:0)]), when a transition occurs on its output. Each interrupt can be programmed to trigger on a 0 to 1 or 1 to 0 output change (CMT register) and may be individually enabled via register CMIE. All interrupts are cleared when the CMIR register is read.

The current output of each comparator (CMV) is available by reading any of the comparator register. When a comparator is powered down, it retains its current output CMV(i) as illustrated in Figure 24, where it is assumed that INN(i) input has a fixed reference voltage. The CMV bits are useful for situations in which it is desirable to poll the state of a comparator; for example, in verifying that a comparator that triggered an interrupt by transitioning through a threshold in a particular direction has not returned to its preceding state. The ability to poll the state of the comparators also allows the use of the comparators without having to enable any of the corresponding interrupts. In many applications, analog input signals change at a very low rate. Users may implement interrupt-based or polling-based algorithms where the comparator is powered up for a very small fraction of time. In this case, the power consumption is minimized.

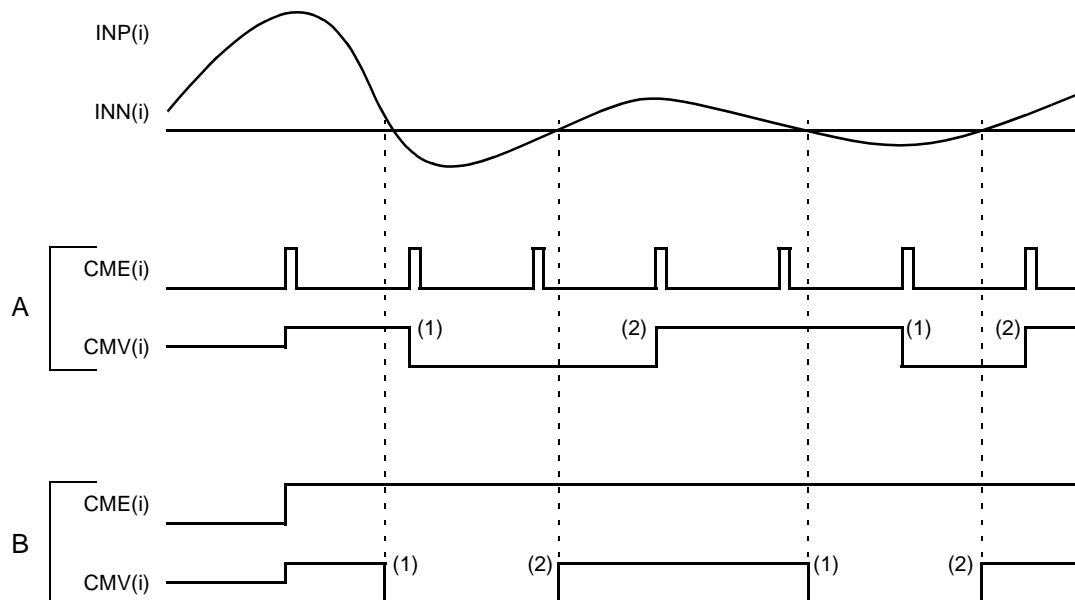

5-6726 (F)

Key:

A: Interrupt generated (CMI[i] = 1), if enabled (CMIE[i] = 1) and falling transition (CMT[i] = 0).

B: Interrupt generated (CMI[i] = 1), if enabled (CMIE[i] = 1) and falling transition (CMT[i] = 1).

Figure 24. (A) CMV When CME Is a Periodic Pulse and (B) CMV When CME Is Static

14 Comparators (continued)

Table 112 shows the major characteristics of the comparators.

Table 112. Comparator Characteristics

Parameter	Conditions	Min	Nom	Max	Unit
Input Common Mode (VCM)	—	0	—	3.2	V
Input Offset Voltage	$0 < VCM < 3.2$	-15	—	15	mV
Gain	$VCM = 1, f = 10 \text{ kHz}$	—	124	—	dB
CMRR	$VCM = 1, f = 10 \text{ kHz}$	—	85	—	dB
PSRR	$VCM = 1, f = 10 \text{ kHz}$	—	79	—	dB
dc Power Dissipation	—	—	0.8	1.5	mW
Standby Power Dissipation	—	—	—	3	μW

14.1 Comparators Register Set

Table 113. CME: Comparator Enable (0x4C)

Reg	R/W	Bit 7	Bit 6	Bit 5	Bit 4	Bit 3	Bit 2	Bit 1	Bit 0
CME	R/W	—	CMV.2	CMV.1	CMV.0	—	CME.2	CME.1	CME.0
RESET	Default	0	—	—	—	0	0	0	0

Bit #	Symbol	Name/Description
7	—	Reserved. Program to 0.
6—4	CMV.[2:0]	Comparator [2:0] Value (Read-Only Field). These status bits indicate the current state of the corresponding comparator output.
3	—	Reserved. Program to 0.
2—0	CME.[2:0]	Comparator [2:0] Enable. 0: Comparator disabled (powerdown mode). 1: Comparator active. Note: On powerdown, any pending interrupts are reset.

Table 114. CMT: Comparator Transition Polarity (0x4D)

Reg	R/W	Bit 7	Bit 6	Bit 5	Bit 4	Bit 3	Bit 2	Bit 1	Bit 0
CMT	R/W	—	CMV.2	CMV.1	CMV.0	—	CMT.2	CMT.1	CMT.0
RESET	Default	0	—	—	—	0	1	1	1

Bit #	Symbol	Name/Description
7	—	Reserved. Program to 0.
6—4	CMV.[2:0]	Comparator [2:0] Value (Read-Only Field). These status bits indicate the current state of the corresponding comparator output.
3	—	Reserved. Program to 0.
2—0	CMT.[2:0]	Comparator [2:0] Transition Polarity. 0: Interrupt on 1-to-0 transition. 1: Interrupt on 0-to-1 transition.

14 Comparators (continued)

14.1 Comparators Register Set (continued)

Table 115. CMIR: Comparator Interrupt Register (0x4E)

Reg	R/W	Bit 7	Bit 6	Bit 5	Bit 4	Bit 3	Bit 2	Bit 1	Bit 0
CMIR	R	—	CMV.2	CMV.1	CMV.0	—	CMI.2	CMI.1	CMI.0
RESET	Default	—	—	—	—	—	—	—	—

Note: Bits CMI.[2:0] in this register are set to 1 upon occurrence of the corresponding interrupt condition, and are cleared to 0 when the register is read.

Bit #	Symbol	Name/Description
7	—	Reserved.
6—4	CMV.[2:0]	Comparator [2:0] Value. These status bits indicate the current state of the corresponding comparator output. No interrupt is generated in response to the value in these bits.
3	—	Reserved.
2—0	CMI.[2:0]	Comparator [2:0] Interrupt. This interrupt indicates that the comparator output has toggled in the direction specified in register CMT.

Table 116. CMIE: Comparator Interrupt Enable (0x4F)

Reg	R/W	Bit 7	Bit 6	Bit 5	Bit 4	Bit 3	Bit 2	Bit 1	Bit 0
CMIE	R/W	—	CMV.2	CMV.1	CMV.0	—	CMIE.2	CMIE.1	CMIE.0
RESET	Default	0	—	—	—	0	0	0	0

Bit #	Symbol	Name/Description
7	—	Reserved. Program to 0.
6—4	CMV.[2:0]	Comparator [2:0] Value (Read-Only Field). These status bits indicate the current state of the corresponding comparator output.
3	—	Reserved. Program to 0.
2—0	CMIE.[2:0]	Comparator [2:0] Interrupt Enable. 0: Interrupt disabled (masked). 1: Interrupt enabled. Masked interrupts are not latched.

14.2 Configuration Sequence

In order to avoid unwanted interrupts when changing the CMT value, the user should satisfy at least one of the following two conditions:

- The comparator interrupt is disabled.
- The comparator is powered down.

15 Test Mode

When the TEST pin (pin 43) is asserted, pins 34, 85, and 97 change their existing functions so that the customer can put the device in ILOSS, single pulses on the U-interface, and pulse template/loopback on S/T-interface test modes, respectively.

When the TEST pin (pin 43) is asserted, pins 29, 30, 32, 35, 40, 41, and 42 also change their existing functions to enable factory testing of the device as explained in Table 3 and Table 7.

Note: The existing functions on the above pins will not be available when the TEST pin is asserted.

16 Loopbacks

Following is a description of the loopbacks supported by the NTN.

The figure below shows the Layer-1 loopbacks that are defined in ITU-T I.430, Appendix I and ANS/ Specification T1.605, Appendix G. A complete discussion of these loopbacks is presented in ITU-T I.430, Appendix I.

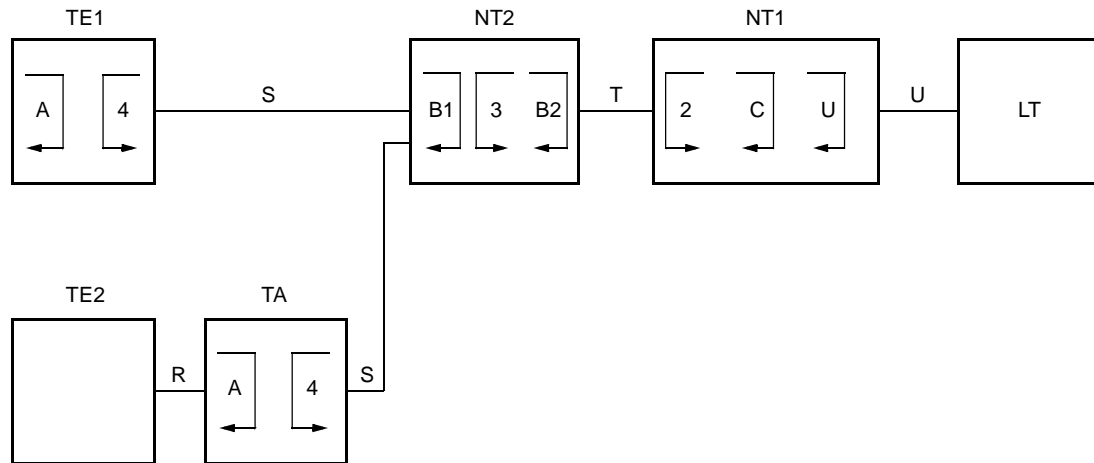

<u>Key</u>		<u>Loopback</u>	<u>Channel(s) Looped</u>
TE1 = ISDN terminal.	R = R reference point.	2	2B+D channels
TE2 = non-ISDN terminal.	S = S reference point.	3	2B+D channels
TA = terminal adapter.	T = T reference point.	4	B1, B2
NT2 = network termination 2.	U = U reference point.	C	B1, B2
NT1 = network termination 1.		B1 or B2	2B+D, B1, B2
LT = line termination.		A	2B+D, B1, B2

5-2482.b (F)

Figure 25. Location of the Loopback Configurations

17 Absolute Maximum Ratings

Stresses in excess of the absolute maximum ratings can cause permanent or latent damage to the device. These are absolute stress ratings only. Functional operation of the device is not implied at these or any other conditions in excess of those given in the operation sections of the data sheet. Exposure to absolute maximum ratings for extended periods can adversely affect device reliability.

External leads can be soldered safely at temperatures up to 300 °C.

Table 117. Absolute Maximum Ratings

Parameter	Symbol	Min	Max	Unit
dc Supply Voltage Range	V _{DD}	-0.5	6.5	V
Storage Temperature	T _{stg}	-55	150	°C
Voltage (any pin) with Respect to GND	—	-0.5	6.5	V

18 Handling Precautions

Although protection circuitry has been designed into this device, proper precautions should be taken to avoid exposure to electrostatic discharge (ESD) during handling and mounting. Lucent employs a human-body model (HBM) and charged-device model (CDM) for ESD-susceptibility testing and protection design evaluation. ESD voltage thresholds are dependent on the circuit parameters used to define the model. No industry-wide standard has been adopted for the CDM. However, a standard HBM (resistance = 1500 Ω, capacitance = 100 pF) is widely used and, therefore, can be used for comparison. The HBM ESD threshold presented here was obtained by using the circuit parameters shown below.

Table 118. ESD Threshold Voltage

Device	Voltage
T9000	>500

19 Recommended Operating Conditions

Table 119. Recommended Operating Conditions

Parameter	Symbol	Test Condition	Min	Typ	Max	Unit
Ambient Temperature	T _A	V _{DD} = 5 V ± 5%	-40	—	85	°C
Any V _{DD}	V _{DD}	—	4.75	5.0	5.25	V
GND to GND	V _{GG}	—	-10	—	10	mV
Voltage Ref Capacitor	C _{VR}	—	0.08	0.1	0.2	μF
Master Clock Frequency	MCLK	—	—	15.36	—	MHz
Master Clock Tolerance	MCLK	NT Mode LT Mode	-225* -225 + x*†	—	-225* -225 + x*†	ppm ppm
Master Clock Duty Cycle	MCLK	—	47	—	53	%

* To meet ANSI T1.601 free-run line rate requirement, NT tolerance is 100 ppm.

† x = tolerance of MTC.

20 Electrical Characteristics

20.1 Power Supply

The NTN operates from one power supply: the digital section from a 5.0 V \pm 5% supply and the analog section from a 5.0 V \pm 5% supply.

20.2 Power Consumption

Table 120. Power Consumption

Conditions	Loop Length		
	0 kft	18 kft	Unit
NT1 Mode U-interface and S/T-interface powered up, microcontroller, and MLSE (see Table 47 for MLSE description) powered down	365	330	mW
<i>Restricted NT1 Power Mode</i> U-interface powered up, S/T-interface, microcontroller, and MLSE powered down	335	300	mW
Intelligent NT1 (INT1) Mode U-interface, S/T-interface, and microcontroller powered up, and MLSE powered down	415	380	mW
<i>Restricted INT1 Power Mode</i> U-interface and microcontroller powered up, S/T-interface, and MLSE powered down	385	350	mW

20.3 S/T-Interface Receiver Common-Mode Rejection

Table 121. S/T-Interface Receiver Common-Mode Rejection

Parameter	Symbol	Specifications	Unit
Common-mode Rejection (at device pins)	CMR	400	mV

20 Electrical Characteristics (continued)

20.4 Pin Electrical Characteristics

Table 122. Digital dc Characteristics (Over Operating Ranges)

Parameter	Symbol	Test Condition	Min	Typ	Max	Unit
Input Leakage Current:						
Low	IILPU	$V_{IL} = 0$	-50	—	-10	μA
High	IIHPU	$V_{IH} = V_{DD}$	—	—	-10	μA
Low	IILPD	$V_{IL} = 0$	-10	—	—	μA
High	IIHPD	$V_{IH} = V_{DD}$	-10	—	-100	μA
Input Voltage:						
Low	V_{IL}	Pins 2, 4—11, 13—21, 23, 26—28, 33—34, 37—38, 40, 43, 45—50, 70, 72—79, 81—88, 90—97, 99—100	—	—	0.9	V
High	V_{IH}	Pins 2, 4—11, 13—21, 23, 26—28, 33—34, 37—38, 40, 43, 45—50, 70, 72—79, 81—88, 90—97, 99—100	3.5	—	—	V
Reset	V_{ILS} V_{IHS} V_H (Hysteresis)	Pin 31	0.5 — —	— — 1.7	— $V_{DD} - 0.5$ —	V V V
Output Leakage Current:						
Low	IOZL	$V_{OL} = 0$ (pins 1, 24, 35)	—	—	10	μA
High	IOZH	$V_{OH} = V_{DD}$ (pins 1, 24, 35)	-10	—	—	μA
Output Voltage:						
Low, TTL	V_{OL}	$I_{OL} = 1.6 \text{ mA}$ (pins 40, 42) $I_{OL} = 3.2 \text{ mA}$ (pins 2, 4—11, 13—20, 23, 26—30, 32, 34, 41, 71—79, 81—88, 91, 93—97, 99, 100)	—	—	0.4	V
High, TTL	V_{OH}	$I_{OH} = 1.6 \text{ mA}$ (pins 40, 42) $I_{OH} = 3.2 \text{ mA}$ (pins 2, 4—11, 13—20, 23, 26—30, 32, 34, 41, 71—79, 81—88, 91, 93—97, 99, 100) $I_{OH} = 4.8 \text{ mA}$ (pins 1, 24, 35, 90, 92)	2.4	—	—	—

21 Crystal Characteristics

Table 123. Fundamental Mode Crystal Characteristics

These are the characteristics of a parallel resonant crystal for meeting the ± 100 ppm requirements of T1.601 for NT operation. The parasitic capacitance of the PC board to which the T9000 crystal is mounted must be kept within the range of $0.6 \text{ pF} \pm 0.4 \text{ pF}$.

Parameter	Symbol	Test Conditions	Specifications	Unit
Center Frequency	F ₀	With 25.0 pF of loading	15.36	MHz
Tolerance Including Calibration, Temperature Stability, and Aging	TOL	—	± 70	ppm
Drive Level	DL	Maximum	0.5	mW
Series Resistance	R _s	Maximum	20	Ω
Shunt Capacitance	C ₀	—	$3.0 \pm 20\%$	pF
Motional Capacitance	C _M	—	$12 \pm 20\%$	fF

Table 124. Internal PLL Characteristics

Parameter	Test Conditions	Min	Typ	Max	Unit
Total Pull Range	—	± 250	—	—	ppm
Jitter Transfer Function	-3 dB point (LT)	—	0.45*	—	Hz
	-3 dB point (NT), 18 kft 26 AWG	—	5*	—	Hz
Jitter Peaking	at 0.15 Hz typical (LT)	—	0.4*	—	dB
	at 1.5 Hz typical (NT)	—	1.0*	—	dB

* Set by digital PLL; therefore, variations track MTC (LT mode) or U-interface line rate (NT mode).

22 Timing Characteristics

Table 125. MTC (Master Timing Clock) Requirements and Characteristics* (LT Mode)

Parameter	Min	Typ	Max	Unit
MTC Clock Period	125 - 32 ppm	125	125 + 32 ppm	μs
MTC High/Low Time	8	—	—	MCLKs
MTC Rise/Fall Time	—	—	60	ns
MTC Jitter	—	—	0.259	UI [†]

* To meet ANSI T1.601-1992, see not for Recommended Operating Conditions.

† One UI = 12.5 μs .

23 Application Diagrams

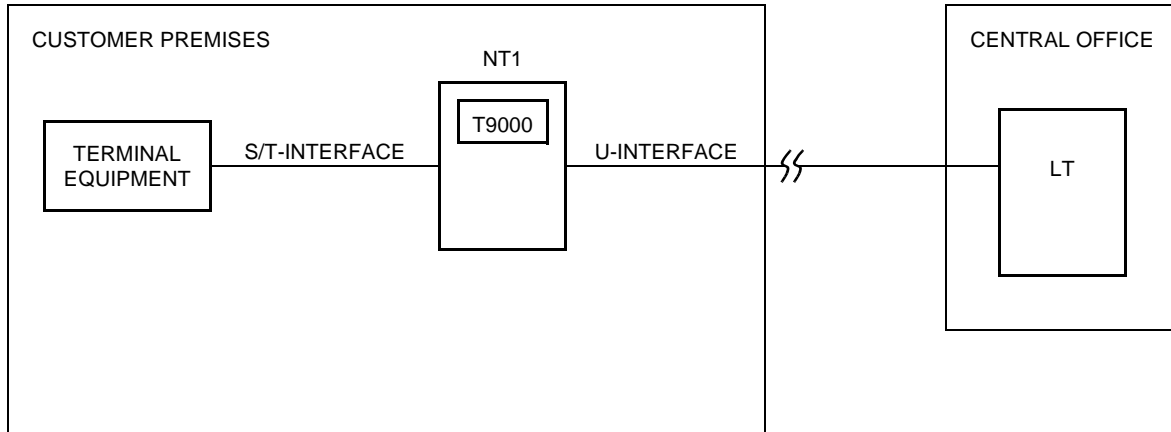

12-3564

Figure 26. NT1 Application

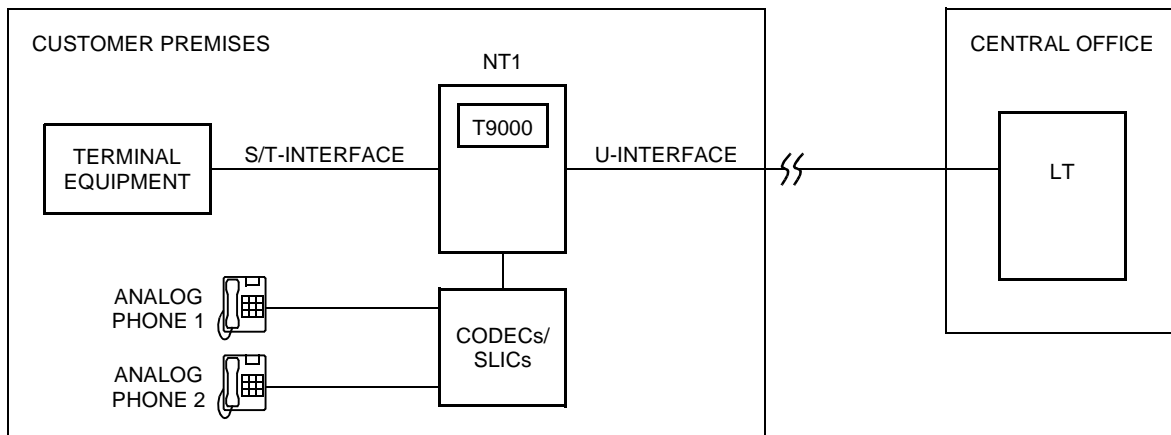

12-3565

Figure 27. NT1+ Application

23 Application Diagrams (continued)

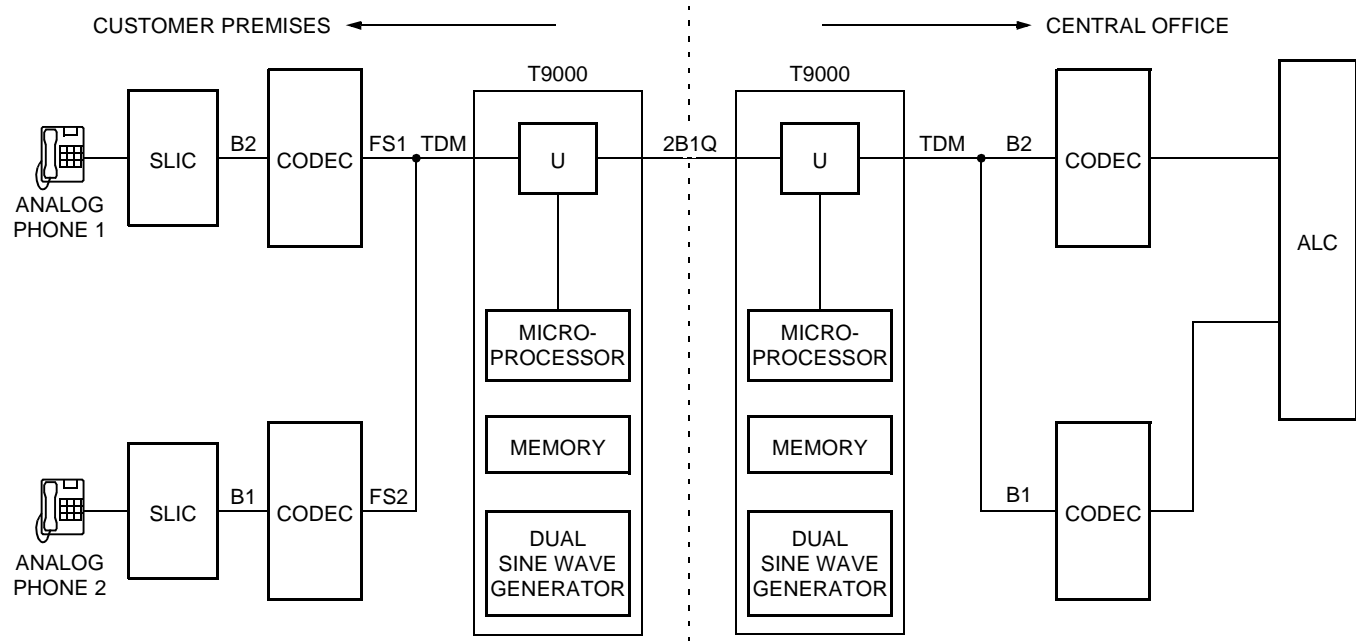

12-3566

LEGEND:

- ALC: Analog line card
- FS1: Frame sync 1
- FS2: Frame sync 2
- SLIC: Subscriber loop interface circuit
- B1, B2: Voice channels

Figure 28. Pair Gain Application

24 Outline Diagram

24.1 100-Pin TQFP

Dimensions are in millimeters.

Note: The dimensions in this outline diagram are intended for informational purposes only. For detailed schematics to assist your design efforts, please contact your Lucent Technologies Account Manager.

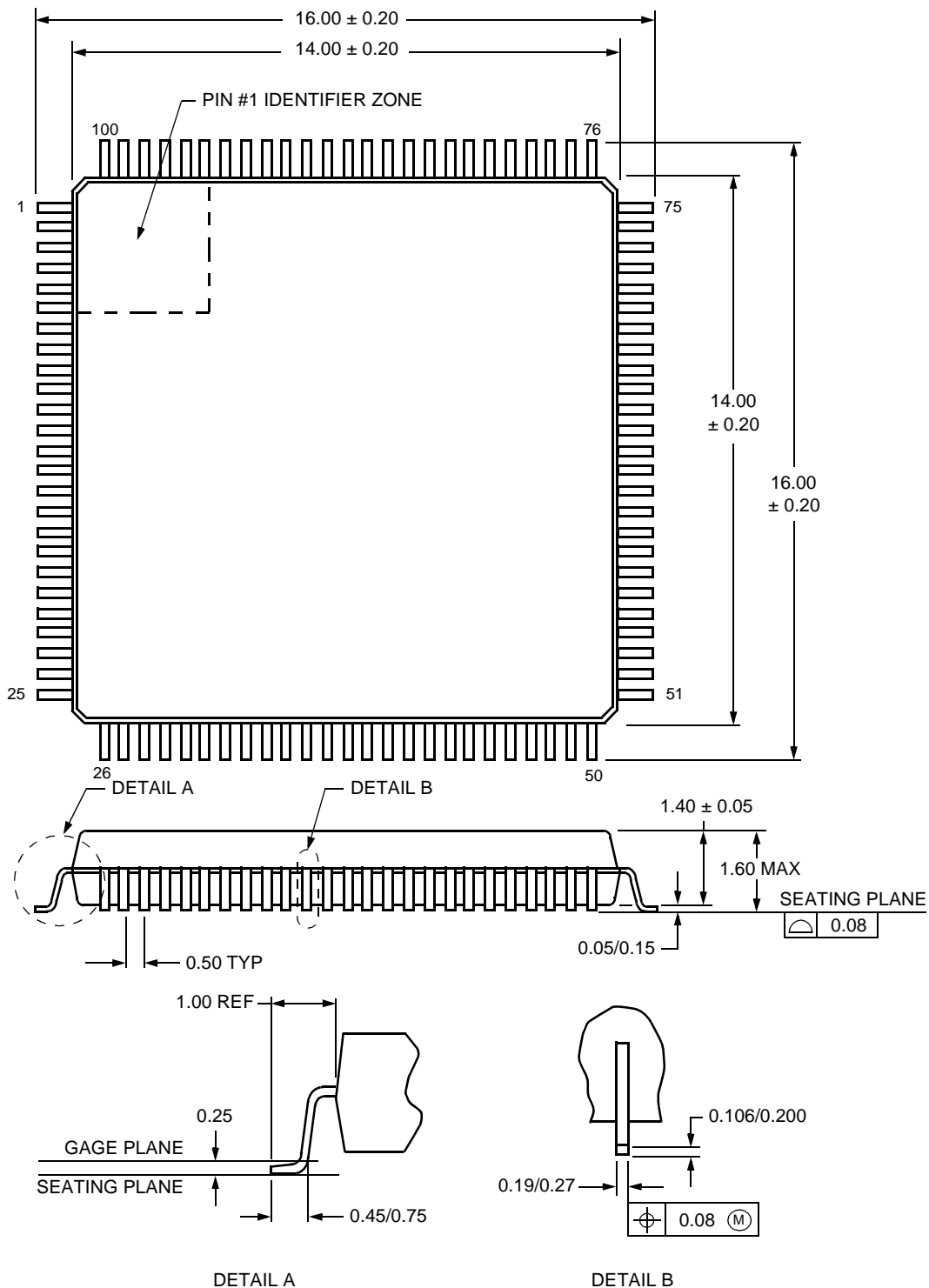

25 Ordering Information

Device Code	Package	Temperature	Comcode
T-9000- - -TL	100-pin TQFP	-40 °C to +85 °C	108556523

26 Register Set Summary

The following section contains tables that list a summary of the entire register set for the T9000.

Table 126. Register Set Summary Global Registers

Reg	R/W	Bit 7	Bit 6	Bit 5	Bit 4	Bit 3	Bit 2	Bit 1	Bit 0
0x00, Global Interrupt Register 0									
GIR0	R	—	—	—	XI0I	125I	UII	SII	GPI0I
RESET	Default	—	—	—	0	0	0	0	0
0x01, Global Interrupt Register 1									
GIR1	R	—	—	—	XI1I	HDLCI	GCII	CMPI	PWMI
RESET	Default	0	0	0	0	0	0	0	0
0x02, Global Interrupt Enable Register									
GIE	R/W	—	—	—	125IE	II1E	XI1E	II0E	XI0E
RESET	Default	0	0	0	0	0	0	0	0
0x03, Microcontroller Clock Control Register									
UPCK	R/W	CLKOE	—	—	—	—	UPCK2	UPCK1	UPCK0
RESET	Default	1	0	0	0	0	1	1	1
0x04, Watchdog Timer									
WDT	R/W	WDTE	WDT6	WDT5	WDT4	WDT3	WDT2	WDT1	WDT0
RESET	Default	0	1	1	1	1	1	1	1

Table 127. Register Set Summary DFAC Registers

0x05, DFAC Configuration Register									
DFCF	R/W	ILOSS	USIMRST	URESET	—	UOADS	ACT_ANSI	AUTOEOC	GRESET
RESET	Default	0	0	0	0	1	0	1	0
0x06, Data Flow Register									
DFR	R/W	U_FORCE_B2UP	U_FORCE_B1UP	FORCE_D	PFS2_ACT	PFS1_ACT	B2_SEL	B1_SEL	BSWAP
RESET	Default	0	0	0	0	0	0	0	0

Table 128. Register Set Summary U-Interface Control Registers

0x07, U-Interface Control Register #0									
UCR0	R/W	NTM_n	PS1	PS2	SAI	XPCY	F_ACTUP	ACTUP	ISTP
RESET	Default	1	1	1	0	0	0	0	0
0x08, U-Interface Control Register #1									
UCR1	R/W	R64T	R25T	R16T	R15T	ULBKMUX	ULLBK	USPMAG	USSP_E
RESET	Default	1	1	1	1	0	0	0	0
0x09, U-Interface Status Register #0									
USR0	R	AIB_n	FEBE_n	NEBE_n	UOA_n	DEA_n	OOF_n	XACT	ACTDN
RESET	Default	1	1	1	1	1	0	0	0
0x0A, U-Interface Status Register #1									
USR1	R	—	R64R	R54R	R44R	R34R	R25R	R16R	R15R
RESET	Default	—	1	1	1	1	1	1	1

26 Register Set Summary (continued)

Table 129. Register Set Summary EOC Control Registers

0x0B, EOC Control Register 0—Command and Address									
Reg	R/W	Bit 7	Bit 6	Bit 5	Bit 4	Bit 3	Bit 2	Bit 1	Bit 0
ECR0	R/W	CCRC	LD	LB2	LB1	A1T	A2T	A3T	DMT
RESET	Default	0	0	0	0	0	0	0	1
0x0C, EOC Control Register 1—Message									
ECR1	R/W	I1T	I2T	I3T	I4T	I5T	I6T	I7T	I8T
RESET	Default	1	1	1	1	1	1	1	1
0x0D, EOC Status Register 0—Command and Address									
ESR0	R	ECCRC	ELD	ELB2	ELB1	A1R	A2R	A3R	DMR
RESET	Default	0	0	0	0	1	1	1	1
0x0E, EOC Status Register 1—Message									
ESR1	R	I1R	I2R	I3R	I4R	I5R	I6R	I7R	I8R
RESET	Default	1	1	1	1	1	1	1	1

Table 130. Register Set Summary S-Interface Registers

0x0F, S-Interface Control Register #0									
SCR0	R/W	—	—	STOA	FACT	FT	MF_E	ST_E	SRESET
RESET	Default	0	0	0	0	0	0	1	0
0x10, S-Interface Control Register #1									
SCR1	R/W	—	—	—	RLB_D	RLB_B2	RLB_B1	TE_DA	—
RESET	Default	0	0	0	0	0	0	0	0
0x11, S-Interface Status Register									
SSR	R	FSERR	—	—	RXINFO3	RXINFO1	ASI2	ASI1	ASI0
RESET	Default	0	—	—	0	0	0	0	0

Table 131. Register Set Summary Multiframe Registers

0x12, Multiframe Register, Q-Channel Data									
MFR0	R	—	—	—	—	QD1	QD2	QD3	QD4
RESET	Default	—	—	—	—	1	1	1	1
0x13, Multiframe Register, S-Subchannel Data									
MFR1	W	—	—	—	—	SSD1	SSD2	SSD3	SSD4
RESET	Default	0	0	0	0	0	0	0	0

Table 132. Register Set Summary U-Interface Interrupt Registers

0x14, U-Interface Interrupt Register									
UIR	R	RSF	RHSF	BERR	ACTSC	OUSC	EOC3SC	EOCSC	ECNFY
RESET	Default	0	0	0	0	0	0	0	0
0x15, U-Interface Interrupt Enable									
UIE	R/W	RSFE	RHSFE	BERRE	ACTSCE	OUSCE	EOC3SCE	EOCSCE	—
RESET	Default	0	0	0	0	0	0	0	—

26 Register Set Summary (continued)

Table 133. Register Set Summary S-Interface Interrupt Registers

0x16, S-Interface Interrupt Register									
SIR	R	—	—	—	—	SSC	FSERR	QSC	SSRDY
RESET	Default	—	—	—	—	0	0	0	0
0x17, S-Interface Interrupt Enable									
SIE	R/W	—	—	—	—	SSCE	FSERRE	QSC	SSRDYE
RESET	Default	0	0	0	0	0	0	0	0
0x50, Device Operation Control Register									
DOCR	R/W	FORCE_SAI _STD	BS_É	—	—	NT_LT	—	—	—
RESET	Default	0	0	0	0	0	0	0	0
0x51, B1-Channel Upstream Data from GCI to U-Interface									
B1UP	R/W	B1UP7	B1UP6	B1UP5	B1UP4	B1UP3	B1UP2	B1UP1	B1UP0
RESET	Default	—	—	—	—	—	—	—	—
0x52, B2-Channel Upstream Data from GCI to U-Interface									
B2UP	R/W	B2UP7	B2UP6	B2UP5	B2UP4	B2UP3	B2UP2	B2UP1	B2UP0
RESET	Default	—	—	—	—	—	—	—	—
0x53, B1-Channel Downstream Data from GCI to U-Interface									
B1DN	R/W	B1DN7	B1DN6	B1DN5	B1DN4	B1DN3	B1DN2	B1DN1	B1DN0
RESET	Default	—	—	—	—	—	—	—	—
0x54, B2-Channel Downstream Data from GCI to U-Interface									
B2DN	R/W	B2DN7	B2DN6	B2DN5	B2DN4	B2DN3	B2DN2	B2DN1	B2DN0
RESET	Default	—	—	—	—	—	—	—	—
0x55, Reserved Register for Internal Use									
Reserved1	R	—	—	—	—	—	—	—	—
RESET	Default	—	—	—	—	—	—	—	—
0x56, Reserved Register for Internal Use									
Reserved2	R/W	—	—	U_FDEACT	U_R54T	MLSE_POWER _DN	—	—	—
RESET	Default	—	—	0	1	0	—	—	—
0x57, Reserved Register for Internal Use									
Reserved3	R	—	—	—	—	—	—	—	—
RESET	Default	—	—	—	—	—	—	—	—
0x58, Reserved Register for Internal Use									
Reserved4	R	—	—	—	—	—	—	—	—
RESET	Default	—	—	—	—	—	—	—	—
0x59, Reserved Register for Internal Use									
Reserved5	R	—	—	—	—	—	—	—	—
RESET	Default	—	—	—	—	—	—	—	—
0x5A, Reserved Register for Internal Use									
Reserved6	R	—	—	—	—	—	—	—	—
RESET	Default	—	—	—	—	—	—	—	—
0x5B, Reserved Register for Internal Use									
Reserved7	R	—	—	—	—	—	—	—	—
RESET	Default	—	—	—	—	—	—	—	—
0x5C, Reserved Register for Internal Use									
Reserved8	R	—	—	—	—	—	—	—	—
RESET	Default	—	—	—	—	—	—	—	—
0x5D, Reserved Register for Internal Use									
Reserved8	R	—	—	—	—	—	—	—	—
RESET	Default	—	—	—	—	—	—	—	—

26 Register Set Summary (continued)

Table 134. Register Set Summary HDLC Registers

Reg	R/W	Bit 7	Bit 6	Bit 5	Bit 4	Bit 3	Bit 2	Bit 1	Bit 0
0x18, HDLC Transmitter Configuration Register									
HTCF	R/W	FCNT2	FCNT1	FCNT0	IDL	TXMODE	ABRT_RQ	MANCRC	TX_INIT
RESET	Default	0	0	0	1	0	0	0	0
0x19, HDLC Receiver Configuration Register									
HRCF	R/W	—	—	—	—	RXMODE	BAE	DROPCRC	RX_INIT
RESET	Default	0	0	0	0	—	0	1	0
0x1A, HDLC Transmit FIFO Threshold									
HTTH	R/W	P_CLASS	—	TFAE5	TFAE4	TFAE3	TFAE2	TFAE1	TFAE0
RESET	Default	1	0	1	0	0	0	0	0
0x1B, HDLC Receive FIFO Threshold									
HRTH	R/W	—	—	RFAF5	RFAF4	RFAF3	RFAF2	RFAF1	RFAF0
RESET	Default	0	0	1	0	0	0	0	0
0x1C, HDLC Transmit FIFO Space Available									
HTSA	R	—	TSP6	TSP5	TSP4	TSP3	TSP2	TSP1	TSP0
RESET	Default	—	1	0	0	0	0	0	0
0x1D, HDLC Receive FIFO Data Available									
HRDA	R	SWRF	NBNSW6	NBNSW5	NBNSW4	NBNSW3	NBNSW2	NBNSW1	NBNSW0
RESET	Default	—	—	—	—	—	—	—	—
0x1E, HDLC Transmit Data									
HTX	W	TXD7	TXD6	TXD5	TXD4	TXD3	TXD2	TXD1	TXD0
RESET	Default	—	—	—	—	—	—	—	—
0x1F, HDLC Transmit Data Last Byte									
HTXL	W	TXDL7	TXDL6	TXDL5	TXDL4	TXDL3	TXDL2	TXDL1	TXDL0
RESET	Default	—	—	—	—	—	—	—	—
0x20, HDLC Receive Data									
HRX	R	RXD7	RXD6	RXD5	RXD4	RXD3	RXD2	RXD1	RXD0
RESET	Default	—	—	—	—	—	—	—	—
0x21, HDLC SAPI C/R Bit Mask Register									
HSCR	R/W	—	—	—	—	S3CRE	S2CRE	S1CRE	S0CRE
RESET	Default	0	0	0	0	0	0	0	0
0x22, HDLC SAPI Match Pattern 0									
HSM0	R/W	SAPI05	SAPI04	SAPI03	SAPI02	SAPI01	SAPI00	C/R0	EA00
		BAP7	BAP6	BAP5	BAP4	BAP3	BAP2	BAP1	BAP0
RESET	Default	—	—	—	—	—	—	—	—

26 Register Set Summary (continued)

Table 134. Register Set Summary HDLC Registers (continued)

Reg	R/W	Bit 7	Bit 6	Bit 5	Bit 4	Bit 3	Bit 2	Bit 1	Bit 0
0x23, HDLC TEI Match Pattern 0									
HTM0	R/W	TEI06	TEI05	TEI04	TEI03	TEI02	TEI01	TEI00	EA10
RESET	Default	—	—	—	—	—	—	—	—
0x24, HDLC SAPI Match Pattern 1									
HSM1	R/W	SAPI15	SAPI14	SAPI13	SAPI12	SAPI11	SAPI10	C/R1	EA01
RESET	Default	—	—	—	—	—	—	—	—
0x25, HDLC TEI Match Pattern 1									
HTM1	R/W	TEI16	TEI15	TEI14	TEI13	TEI12	TEI11	TEI10	EA11
RESET	Default	—	—	—	—	—	—	—	—
0x26, HDLC SAPI Match Pattern 2									
HSM2	R/W	SAPI25	SAPI24	SAPI23	SAPI22	SAPI21	SAPI20	C/R2	EA02
RESET	Default	—	—	—	—	—	—	—	—
0x27, HDLC TEI Match Pattern 2									
HTM2	R/W	TEI26	TEI25	TEI24	TEI23	TEI22	TEI21	TEI20	EA12
RESET	Default	—	—	—	—	—	—	—	—
0x28, HDLC SAPI Match Pattern 3									
HSM3	R/W	SAPI35	SAPI34	SAPI33	SAPI32	SAPI31	SAPI30	C/R3	EA03
RESET	Default	—	—	—	—	—	—	—	—
0x29, HDLC TEI Match Pattern 3									
HTM3	R/W	TEI36	TEI35	TEI34	TEI33	TEI32	TEI31	TEI30	EA13
RESET	Default	—	—	—	—	—	—	—	—
0x2A, HDLC SAPI Modifier Register									
HSMOD	R/W	SAPI3M1	SAPI3M0	SAPI2M1	SAPI2M0	SAPI1M1	SAPI1M0	SAPI0M1	SAPI0M0
RESET	Default	0	0	0	0	0	0	0	0
0x2B, HDLC TEI Modifier Register									
HTMOD	R/W	TEI3M1	TEI3M0	TEI2M1	TEI2M0	TEI1M1	TEI1M0	TEI0M1	TEI0M0
RESET	Default	0	0	0	0	0	0	0	0
0x2C, HDLC Interrupt Register									
HDIR	R	RSTF	ROVR	REOF	RABT	RTHR	TUNDR	TFC	TTHR
RESET	Default	—	—	—	—	—	—	—	—
0x2D, HDLC Interrupt Enable Register									
HDIE	R	RSTFE	ROVRE	REOFE	RABTE	RTHRE	TUNDRE	TFCE	TTHRE
RESET	Default	0	0	0	0	0	0	0	0

26 Register Set Summary (continued)

Table 135. Register Set Summary GCI+ Registers

Reg	R/W	Bit 7	Bit 6	Bit 5	Bit 4	Bit 3	Bit 2	Bit 1	Bit 0
0x2E, GCI+ Configuration Register									
GCCF	R/W	GDRIVER	PFSDEL	PFSPE	CKMODE	GRATE1	GRATE0	GMODE1	GMODE0
RESET	Default	0	0	0	0	0	0	0	0
0x2F, GCI+ PFS1 Offset Select									
GCOF1	R/W	GTMODE	G_R_LBK	G_L_LBK	OFF14	OFF13	OFF12	OFF11	OFF10
RESET	Default	0	0	0	0	0	0	0	0
0x30, GCI+ PFS2 Offset Select									
GCOF2	R/W	U_FORCE _B2DN	U_FORC E_B1DN	—	OFF24	OFF23	OFF22	OFF21	OFF20
RESET	Default	0	0	0	0	0	0	0	0
0x31, GCI Downstream (Transmit) Monitor Data									
GCDMD	W	DMD7	DMD6	DMD5	DMD4	DMD3	DMD2	DMD1	DMD0
RESET	Default	1	1	1	1	1	1	1	1
0x32, GCI Downstream (Transmit) Monitor Data Last									
GCDML	W	DML7	DML6	DML5	DML4	DML3	DML2	DML1	DML0
RESET	Default	1	1	1	1	1	1	1	1
0x33, GCI Upstream (Receive) Monitor Data									
GCUMD	R	UMD7	UMD6	UMD5	UMD4	UMD3	UMD2	UMD1	UMD0
RESET	Default	—	—	—	—	—	—	—	—
0x34, GCI Downstream (Transmit) C/I Data									
GCDCI	R/W	—	—	DCI6	DCI5	DCI4	DCI3	DCI2	DCI1
RESET	Default	0	0	—	—	—	—	—	—
0x35, GCI Upstream (Receive) C/I Data									
GCUCI	R/W	—	—	UCI6	UCI5	UCI4	UCI3	UCI2	UCI1
RESET	Default	0	0	—	—	—	—	—	—
0x36, GCI Interrupt Register									
GCIR	R	GWUP	UCIC	UMRDY	UMEOM	UMABRT	DMRDY	DMEOM	DMABRT
RESET	Default	0	0	0	0	0	0	0	0
0x37, GCI Interrupt Enable									
GCIE	R	GWUPE	UCICE	UMRDYE	UMEOME	UMABRT E	DMRDYE	DMEOME	DMABRT E
RESET	Default	0	0	0	0	0	0	0	0

26 Register Set Summary (continued)

Table 136. Register Set Summary GPIO Registers

Reg	R/W	Bit 7	Bit 6	Bit 5	Bit 4	Bit 3	Bit 2	Bit 1	Bit 0
0x38, GPIO Port 0 Pin Direction									
GPDIR0	R/W	DIR0.7	DIR0.6	DIR0.5	DIR0.4	DIR0.3	DIR0.2	DIR0.1	DIR0.0
RESET	Default	1	1	1	1	1	1	1	1
0x39, GPIO Port 1 Pin Direction									
GPDIR1	R/W	DIR1.7	DIR1.6	DIR1.5	DIR1.4	DIR1.3	DIR1.2	DIR1.1	DIR1.0
RESET	Default	1	1	1	1	1	1	1	1
0x3A, GPIO Port 2 Pin Direction									
GPDIR2	R/W	DIR2.7	DIR2.6	DIR2.5	DIR2.4	DIR2.3	DIR2.2	DIR2.1	DIR2.0
RESET	Default	1	1	1	1	1	1	1	1
0x3B, GPIO Alternate Function Register #0									
GPAF0	R/W	GPAF0.7	GPAF0.6	GPAF0.5	GPAF0.4	—	—	—	—
RESET	Default	0	0	0	0	0	0	0	0
0x3C, GPIO Alternate Function Register #1									
GPAF1	R/W	GPAF1.7	GPAF1.6	GPAF1.5	—	GPAF2.3	GPAF2.2	GPAF2.1	GPRESET
RESET	Default	0	0	0	0	0	0	0	0
0x3D, GPIO Port 0 Data Register									
GPD0	R/W	GPD0.7	GPD0.6	GPD0.5	GPD0.4	GPD0.3	GPD0.2	GPD0.1	GPD0.0
RESET	Default	0	0	0	0	0	0	0	0
0x3E, GPIO Port 1 Data Register									
GPD1	R/W	GPD1.7	GPD1.6	GPD1.5	GPD1.4	GPD1.3	GPD1.2	GPD1.1	GPD1.0
RESET	Default	0	0	0	0	0	0	0	0
0x3F, GPIO Port 2 Data Register									
GPD2	R/W	GPD2.7	GPD2.6	GPD2.5	GPD2.4	GPD2.3	GPD2.2	GPD2.1	GPD2.0
RESET	Default	0	0	0	0	0	0	0	0
0x40, GPIO Level-Edge-Triggered Interrupt Control									
GPLEI	R/W	ILE1.3	ILE1.2	ILE1.1	ILE1.0	ILE0.3	ILE0.2	ILE0.1	ILE0.0
RESET	Default	1	1	1	1	1	1	1	1
0x41, GPIO Interrupt Polarity Control									
GPPOL	R/W	IPOL1.3	IPOL1.2	IPOL1.1	IPOL1.0	IPOL0.3	IPOL0.2	IPOL0.1	IPOL0.0
RESET	Default	1	1	1	1	1	1	1	1
0x42, GPIO Interrupt Register									
GPIR	R/W	GPI1.3	GPI1.2	GPI1.1	GPI1.0	GPI0.3	GPI0.2	GPI0.1	GPI0.0
RESET	Default	—	—	—	—	—	—	—	—
0x43, GPIO Interrupt Enable									
GPIE	R/W	GPIE13	GPIE12	GPIE11	GPIE10	GPIE03	GPIE02	GPIE01	GPIE00
RESET	Default	—	—	—	—	—	—	—	—

26 Register Set Summary (continued)

Table 137. Register Set Summary PWM Registers

Reg	R/W	Bit 7	Bit 6	Bit 5	Bit 4	Bit 3	Bit 2	Bit 1	Bit 0
0x44, Pulse-Width Modulator #0 Configuration									
PW0CF	R/W	PW0_E	PW0AUTO	PW0IE	PW0G.2	PW0G.1	PW0G.0	PW0R.1	PW0R.0
RESET	Default	0	—	0	—	—	—	—	—
0x45, Pulse-Width Modulator #0 Pulse-Width Value, High Byte									
PW0VH	R/W	PW0VH7	PW0VH6	PW0VH5	PW0VH4	PW0VH3	PW0VH2	PW0VH1	PW0VH0
RESET	Default	—	—	—	—	—	—	—	—
0x46, Pulse-Width Modulator #0 Pulse-Width Value, Low Byte									
PW0VL	R/W	PW0VL7	PW0VL6	PW0VL5	PW0VL4	PW0VL3	PW0VL2	PW0VL1	PW0VL0
RESET	Default	—	—	—	—	—	—	—	—
0x47, Pulse-Width Modulator #1 Configuration									
PW1CF	R/W	PW1_E	PW1AUTO	PW1IE	PW1G.2	PW1G.1	PW1G.0	PW1R.1	PW1R.0
RESET	Default	0	—	0	—	—	—	—	—
0x48, Pulse-Width Modulator #1 Pulse-Width Value, High Byte									
PW1VH	R/W	PW1VH7	PW1VH6	PW1VH5	PW1VH4	PW1VH3	PW1VH2	PW1VH1	PW1VH0
RESET	Default	—	—	—	—	—	—	—	—
0x49, Pulse-Width Modulator #1 Pulse-Width Value, Low Byte									
PW1VL	R/W	PW1VL7	PW1VL6	PW1VL5	PW1VL4	PW1VL3	PW1VL2	PW1VL1	PW1VL0
RESET	Default	—	—	—	—	—	—	—	—
0x4A, Pulse-Width Modulator Interrupt Register									
PWIR	R	—	—	—	—	—	—	PW1I	PW0I
RESET	Default	—	—	—	—	—	—	0	0

Table 138. Register Set Summary dc/dc Register

0x4B, dc/dc Configuration Register									
DCCF	R/W	—	—	DC_E	DCV4	DCV3	DCV2	DCV1	DCV0
RESET	Default	0	0	0	—	—	—	—	—

26 Register Set Summary (continued)

Table 139. Register Set Summary Comparator Registers

0x4C, Comparator Enable									
CME	R/W	—	CMV.2	CMV.1	CMV.0	—	CME.2	CME.1	CME.0
RESET	Default	0	—	—	—	0	0	0	0
0x4D, Comparator Transition Polarity									
CMT	R/W	—	CMV.2	CMV.1	CMV.0	—	CMT.2	CMT.1	CMT.0
RESET	Default	0	—	—	—	0	1	1	1
0x4E, Comparator Interrupt Register									
CMIR	R	—	CMV.2	CMV.1	CMV.0	—	CMI.2	CMI.1	CMI.0
RESET	Default	—	—	—	—	—	1	1	1
0x4F, Comparator Interrupt Enable									
CMIE	R/W	—	CMV.2	CMV.1	CMV.0	—	CMIE.2	CMIE.1	CMIE.0
RESET	Default	0	—	—	—	0	0	0	0

For additional information, contact your Microelectronics Group Account Manager or the following:

INTERNET: <http://www.lucent.com/micro>

E-MAIL: docmaster@micro.lucent.com

N. AMERICA: Microelectronics Group, Lucent Technologies Inc., 555 Union Boulevard, Room 30L-15P-BA, Allentown, PA 18103

1-800-372-2447, FAX 610-712-4106 (In CANADA: **1-800-553-2448**, FAX 610-712-4106)

ASIA PACIFIC: Microelectronics Group, Lucent Technologies Singapore Pte. Ltd., 77 Science Park Drive, #03-18 Cintech III, Singapore 118256

Tel. (65) 778 8833, FAX (65) 777 7495

CHINA: Microelectronics Group, Lucent Technologies (China) Co., Ltd., A-F2, 23/F, Zao Fong Universe Building, 1800 Zhong Shan Xi Road, Shanghai 200233 P. R. China **Tel. (86) 21 6440 0468, ext. 316**, FAX (86) 21 6440 0652

JAPAN: Microelectronics Group, Lucent Technologies Japan Ltd., 7-18, Higashi-Gotanda 2-chome, Shinagawa-ku, Tokyo 141, Japan

Tel. (81) 3 5421 1600, FAX (81) 3 5421 1700

EUROPE: Data Requests: MICROELECTRONICS GROUP DATALINE: **Tel. (44) 7000 582 368**, FAX (44) 1189 328 148

Technical Inquiries: GERMANY: **(49) 89 95086 0** (Munich), UNITED KINGDOM: **(44) 1344 865 900** (Ascot),

FRANCE: **(33) 1 40 83 68 00** (Paris), SWEDEN: **(46) 8 594 607 00** (Stockholm), FINLAND: **(358) 9 4354 2800** (Helsinki),

ITALY: **(39) 02 6608131** (Milan), SPAIN: **(34) 1 807 1441** (Madrid)

Lucent Technologies Inc. reserves the right to make changes to the product(s) or information contained herein without notice. No liability is assumed as a result of their use or application. No rights under any patent accompany the sale of any such product(s) or information.