

TOSHIBA

TA1272AF

TOSHIBA BIPOLAR LINEAR INTEGRATED CIRCUIT SILICON MONOLITHIC

TA1272AF

FOR LCD TVS, PIF AND SIF SYSTEM

FEATURES

PIF circuit

- High input sensitivity
- 3-stage variable-gain PIF amplifier
- Output with black noise inverter
- Output without black noise inverter
- High-speed response peak AGC with dual time constant
- Reverse RF AGC output
- Built-in AFT detection circuit with AFT mute

SIF circuit

- 4-stage SIF amplifier
- Quadrature-type detection circuit

RF AGC CURVE

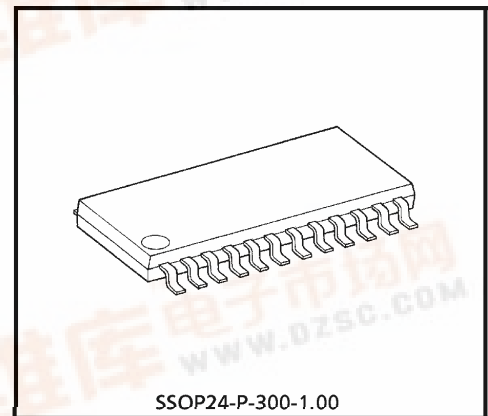
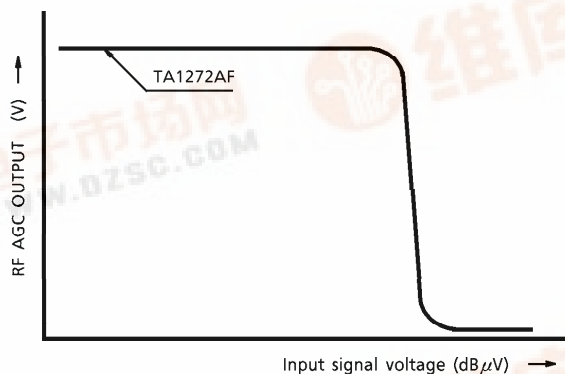

Weight : 0.32 g (Typ.)

980910EBA1

- TOSHIBA is continually working to improve the quality and the reliability of its products. Nevertheless, semiconductor devices in general can malfunction or fail due to their inherent electrical sensitivity and vulnerability to physical stress. It is the responsibility of the buyer, when utilizing TOSHIBA products, to observe standards of safety, and to avoid situations in which a malfunction or failure of a TOSHIBA product could cause loss of human life, bodily injury or damage to property. In developing your designs, please ensure that TOSHIBA products are used within specified operating ranges as set forth in the most recent products specifications. Also, please keep in mind the precautions and conditions set forth in the TOSHIBA Semiconductor Reliability Handbook.
- The products described in this document are subject to the foreign exchange and foreign trade laws.
- The information contained herein is presented only as a guide for the applications of our products. No responsibility is assumed by TOSHIBA CORPORATION for any infringements of intellectual property or other rights of the third parties which may result from its use. No license is granted by implication or otherwise under any intellectual property or other rights of TOSHIBA CORPORATION or others.
- The information contained herein is subject to change without notice.

BLOCK DIAGRAM

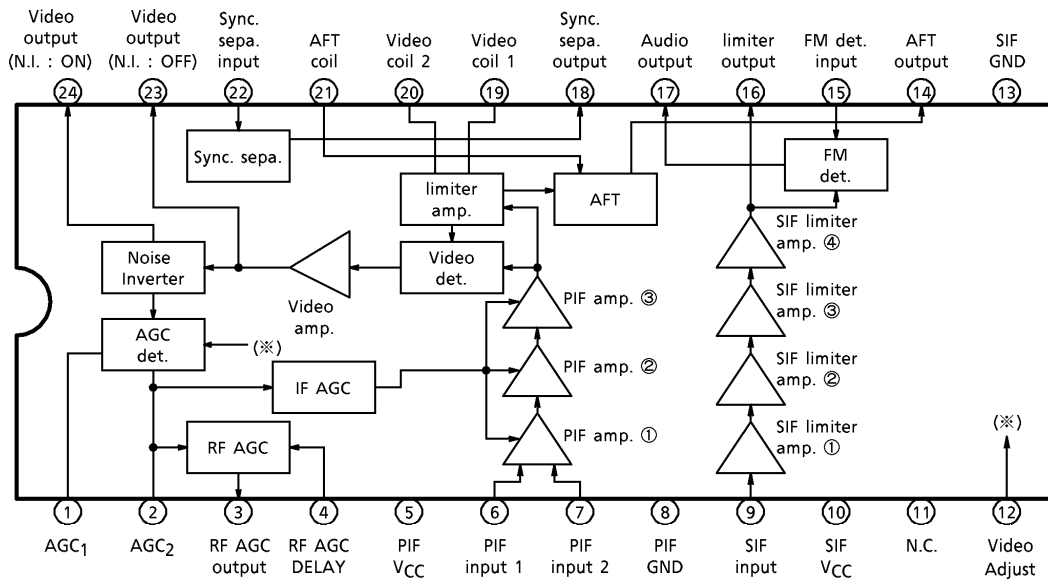

TERMINAL FUNCTION

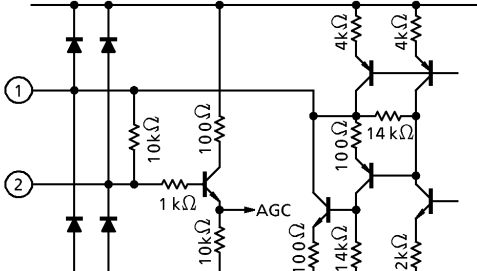
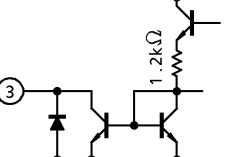
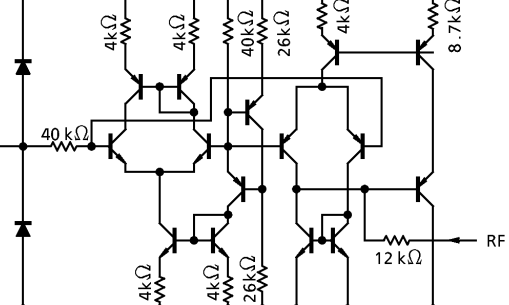
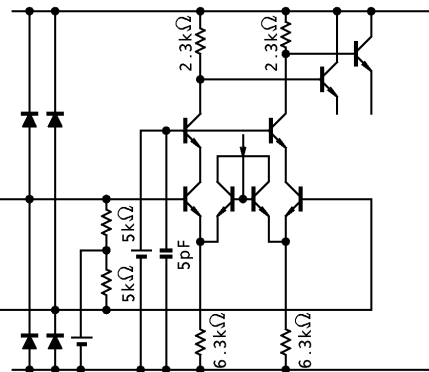
| PIN No. | PIN NAME | FUNCTION | INTERFACE |
|---------|--|---|--|
| 1 2 | PIF AGC ₁ PIF AGC ₂ | This IC is adopted dual time constant AGC circuit to improve AGC responsibility. To mute picture, connect 1.6 kΩ between pin 1 and GND. |  |
| 3 | RF AGC Output | RF AGC output terminal (open-collector output) |  |
| 4 | RF AGC Delay | Changing comparator reference voltage adjusts RF AGC delay point. |  |
| 5 | PIF V _{CC} | Connect bypass capacitor between this terminal and PIF GND with shortest wiring. | — |
| 6 7 | PIF Input 1 PIF Input 2 | PIF input terminal. Input impedance 5 kΩ (Typ.) |  |
| 8 | PIF GND | Connect bypass capacitor between this terminal and PIF V _{CC} with shortest wiring. | — |

| PIN No. | PIN NAME | FUNCTION | INTERFACE |
|---------|---------------------|---|-----------|
| 9 | SIF Input | Connect BPF between this terminal and pin 23. | |
| 10 | SIF V _{CC} | Connect bypass capacitor between this terminal and SIF GND with shortest wiring. | — |
| 11 | N.C. | — | — |
| 12 | Video Adjust | <p>Video signal output voltage adjustment terminal. Changing this terminal voltage, it is possible to adjust video signal output voltage to 1.0 V_{p-p}. (In case of use on adjustment free, connect resistor (330 kΩ) (※) to GND.) To prevent noise, connecting capacitor (0.01 μF) to GND is recommended. (※ resistance tolerance : ± 5%)</p> | |
| 13 | SIF GND | Connect bypass capacitor between this terminal and SIF V _{CC} with shortest wiring. | — |
| 14 | AFT Output | <p>AFT detector output terminal based on double balanced multiplier. AFT output is muted when AFT coil terminal is connected to GND.</p> | |

| PIN No. | PIN NAME | FUNCTION | INTERFACE |
|----------|------------------------------|---|-----------|
| 15 | FM Det. Input | Quadrature input terminal for FM detection circuit. Connect FM coil between this terminal and pin 16. Audio output is muted when this terminal is connected to GND. | |
| 17 | Audio Output | Audio signal output terminal. | |
| 16 | Limiter Output | Limiter output terminal. Connect FM coil between this terminal and pin 15. | |
| 18 22 | Sync. Sepa. | Sync. sepa. output and input terminal. | |
| 19 20 | Video Coil 1 Video Coil 2 | Connect video connection coil. | |

| PIN No. | PIN NAME | FUNCTION | INTERFACE |
|----------|--|---|-----------|
| 21 | AFT Coil | Connect AFT detection coil. AFT output is defeated when this terminal connected to GND. | |
| 23 24 | Video Output 1 Video Output 2 | Video signal output terminal. Pin 23 is the output without noise inverter, and can thus be used for diversity circuit, for example. Pin 24 is the output with noise inverter. | |

MAXIMUM RATINGS (Ta = 25°C)

| CHARACTERISTIC | SYMBOL | RATING | UNIT |
|-----------------------|-----------------------|---------|------|
| Power Supply Voltage | V _{CC} | 8 | V |
| Power Dissipation | P _D (Note) | 500 | mW |
| Operating Temperature | T _{opr} | -20~65 | °C |
| Storage Temperature | T _{stg} | -55~150 | °C |

(Note) When using the device at above Ta = 25°C, decrease the power dissipation by 4 mW for each increase of 1°C.

RECOMMENDED POWER SUPPLY

| PIN No. | PIN NAME | MIN. | TYP. | MAX. | UNIT |
|---------|---------------------|------|------|------|------|
| 5 | PIF V _{CC} | 3.5 | 4.5 | 5.5 | V |
| 9 | SIF V _{CC} | 3.5 | 4.5 | 5.5 | V |

ELECTRIC CHARACTERISTICS (Unless otherwise specified, V_{CC} = 4.5 V, Ta = 25°C)

DC CHARACTERISTICS

| PIN No. | PIN NAME | FUNCTION | MIN. | TYP. | MAX. | UNIT |
|---------|---------------------|---|------|------|------|------|
| 1 | AGC ₁ | 1st AGC filter | — | 4.2 | — | V |
| 2 | AGC ₂ | 2nd AGC filter | — | 4.2 | — | |
| 3 | RF AGC | RF AGC output | — | — | — | |
| 4 | RF AGC delay | RF AGC delay | — | — | — | |
| 5 | PIF V _{CC} | PIF V _{CC} | — | 4.5 | — | |
| 6 | PIF input 1 | IF input | 2.5 | 2.9 | 3.2 | |
| 7 | PIF input 2 | IF input | 2.5 | 2.9 | 3.2 | |
| 8 | PIF GND | PIF GND | — | 0 | — | |
| 9 | SIF input | SIF input | 4.3 | 4.45 | 4.6 | |
| 10 | SIF V _{CC} | SIF V _{CC} | — | 4.5 | — | |
| 11 | N.C. | — | — | — | — | |
| 12 | Video Adjust | Video Adjust | 0.55 | 0.85 | 1.15 | |
| 13 | SIF GND | SIF GND | — | 0 | — | |
| 14 | AFT output | AFT output | 1.3 | 1.8 | 3.2 | |
| 15 | FM det. input | FM det. output | 3.5 | 3.7 | 3.9 | |
| 16 | Limiter output | SIF limiter output | 2.55 | 2.75 | 2.95 | |
| 17 | Audio output | Audio signal output | 1.7 | 2.1 | 2.5 | |
| 18 | Sync. sepa. output | Sync. sepa. signal output | — | — | — | |
| 19 | Video coil 1 | PIF carrier output | 4.05 | 4.15 | 4.25 | |
| 20 | Video coil 2 | PIF carrier output | 4.05 | 4.15 | 4.25 | |
| 21 | AFT coil | Connecting AFT coil | 4.35 | 4.45 | 4.55 | |
| 22 | Sync. sepa. input | Sync. sepa. signal output | — | — | — | |
| 23 | Video output 1 | Video signal output (noise inverter : OFF) | 1.40 | 1.85 | 2.30 | |
| 24 | Video output 2 | Video signal output (noise inverter : ON) | 1.40 | 1.85 | 2.30 | |

AC CHARACTERISTICS (Unless otherwise specified, $V_{CC} = 4.5\text{ V}$, $T_a = 25^\circ\text{C}$)

PIF circuit

| CHARACTERISTIC | SYMBOL | TEST CIRCUIT | CONDITION | MIN. | TYP. | MAX. | UNIT |
|---|-----------------------|--------------|--|------|---------|------|------------------------|
| Power Supply Current at No Signal | I_{PIF} | 1 | — | — | 11 | 16 | mA |
| Output Signal Voltage | V_D | 2 | (Note 1) | 0.8 | 1.0 | 1.2 | V_{p-p} |
| PIF Input Signal Voltage Sensitivity | V_i MIN | 2 | (Note 2) | — | 43 | 50 | $\text{dB}\mu\text{V}$ |
| Maximum input Signal Voltage | V_i MAX | 2 | (Note 3) | 95 | 114 | — | $\text{dB}\mu\text{V}$ |
| – 3 dB Video Band Width | BW | 2 | (Note 4) | 5 | 6.5 | — | MHz |
| Dependence of Output Signal Voltage On Power Supply Voltage | V_D/V_{CC} | 2 | (Note 5) | — | ± 5 | — | % / V |
| Deferential Gain | DG | 3 | (Note 6) | — | 5 | 10 | % |
| Deferential Phase | DP | | | — | 4 | 8 | $^\circ$ |
| Signal-Noise Ratio | S / N | 2 | (Note 7) | 40 | 45 | — | dB |
| Intermodulation | IM | 4 | (Note 8) | 30 | 35 | — | dB |
| Suppression of Picture Career | CR | 2 | (Note 9) | 45 | 50 | — | dB |
| Sync. Voltage Level | V_p | 2 | White 100% | 0.5 | 0.75 | 1.0 | V |
| Output Voltage at No Signal | V_z | 2 | (Note 10) | 1.6 | 2.0 | 2.4 | V |
| Black Noise Inverter Level | V_{BTH} | 2 | (Note 11) Video output 2 | 0.4 | 0.6 | 0.8 | V |
| Black Noise Clamp Level | V_{BCL} | | | 1.0 | 1.2 | 1.4 | |
| AFT Control Steepness | $\Delta f / \Delta V$ | 2 | Load : $75\text{ k}\Omega / 75\text{ k}\Omega$ | 10 | 20 | 30 | kHz / V |
| AFT maximum Output Voltage | V_{MAX} | | | 4.0 | 4.3 | 4.5 | V |
| AFT minimum Output Voltage | V_{MIN} | | | — | 0.3 | 0.5 | |
| AFT Mute Voltage | V_{MUTE} | | | 2.1 | 2.25 | 2.4 | |

SIF circuit

| CHARACTERISTIC | SYMBOL | TEST CIR-CUIT | CONDITION | MIN. | TYP. | MAX. | UNIT |
|---|----------------------------------|---------------|-----------|------|------|------|-------------------|
| Power Supply Current at No Signal | ISIF | 1 | — | — | 6 | 11 | mA |
| Output Signal Voltage | VOD | 2 | (Note 12) | 120 | 150 | 180 | mV _{rms} |
| SIF Input Signal Voltage Sensitivity | V _{LIM} | 2 | (Note 13) | 30 | 35 | 40 | dB _{μV} |
| Total Harmonic Distortion | THD (DET) | 2 | (Note 14) | — | 0.4 | 1.0 | % |
| AM Rejection | AMR | 5 | (Note 15) | 30 | 45 | — | dB |
| Signal-Noise Ratio | S/N DET | 2 | (Note 16) | 50 | 65 | — | dB |
| – 3 dB Bandwidth | BW – 3 dB | 2 | (Note 17) | 180 | 230 | — | kHz |
| Dependence of Output Signal Voltage On Power Supply Voltage | V _{OD} /V _{CC} | 2 | (Note 18) | — | 10 | 15 | % / V |

Sync. sepa. circuit

| CHARACTERISTIC | SYMBOL | TEST CIR-CUIT | CONDITION | MIN. | TYP. | MAX. | UNIT |
|------------------------------------|-----------------------|---------------|--------------|------|------|------|------|
| Sync. Sepa. input Voltage | V _{SYNC.IN} | 2 | — | 1.8 | 2.1 | 3.0 | V |
| Sync. Sepa. Minimum Output Voltage | V _{SYNC.MIN} | 2 | Load : 47 kΩ | 0 | 0.2 | 0.4 | V |
| Sync. Sepa. Maximum Output Voltage | V _{SYNC.MAX} | 2 | | 4.3 | 4.5 | — | V |

TEST CONDITION

<PIF circuit>

(Note 1) Output signal voltage

PIF input : $f_o = 58.75$ MHz, 87.5% AM, 84 dB μ V, White 100%
Measure output video signal voltage.

(Note 2) PIF input signal voltage sensitivity

PIF input : $f_o = 58.75$ MHz, $f_m = 15.75$ kHz, 30% AM, 84 dB μ V
Measure output video signal voltage (that voltage is 0 dB) Lower input signal voltage gradually, measure input PIF signal voltage when output video signal voltage is -3 dB.

(Note 3) Maximum input signal voltage

PIF input : $f_o = 58.75$ MHz, $f_m = 15.75$ kHz, 30% AM, 84 dB μ V
Measure output video signal voltage (that voltage is 0 dB) Raise input signal voltage gradually, measure input PIF signal voltage when output video signal voltage is +3 dB

(Note 4) -3 dB video band width

(1) PIF input :

$f_o = 58.75$ MHz, 84 dB μ V, CW

Measure IF AGC voltage and supply that voltage from external source.

(2) Input following composite signals to the PIF input :

| | | |
|---|--------|--|
| { | SG : 1 | 58.75 MHz, 84 dB μ V (frequency : fixed) |
| | SG : 2 | 58.65~45 MHz, 64 dB μ V (frequency : variable) |

Monitor spectrum of output signal at pin 24. Change frequency of SG : 2, measure frequency of SG : 2, when video output signal is -3 dB.

Difference between that frequency and 58.75 MHz is -3 dB band width.

(Note 5) Dependence of output signal voltage on power supply voltage

PIF input : $f_o = 58.75$ MHz, 87.5% AM, 84 dB μ V, standard TV signal (V/S = 10 : 4 Ramp)

Measure the output video signal voltage when power supply voltage are 3.5 V and 5.5 V. (4.5 \pm 1.0 V)

Compare those voltage and the output video signal voltage when power supply voltage is 4.5 V.

(Note 6) Deferential gain / Deferential phase

PIF input : $f_o = 58.75$ MHz, 87.5% AM, 84 dB μ V, standard TV signal (V/S = 10 : 4 Ramp) IF AGC : free

Measure deferential gain and deferential phase.

(Note 7) Signal-noise ratio

(1) PIF input : $f_o = 58.75$ MHz, $f_m = 15.75$ kHz, 30%AM, 84 dB μ V
 Measure IF AGC voltage and supply that voltage from external source.

(2) Measure output video signal voltage. : V_1

(3) PIF input : $f_o = 58.75$ MHz, 84 dB μ V, CW
 Measure output video signal voltage. : V_2
 Signal-noise ratio is calculated by following equality.

$$\text{Signal-noise ratio} = 20 \log (V_1 \times 6 / V_2) \text{ (dB)}$$

(Note 8) Intermodulation

(1) PIF input : $f_o = 58.75$ MHz, 84 dB μ V, CW
 Supply DC voltage to IF AGC from external source to fix IF AGC voltage.

(2) PIF input : following composite signals
 $f_o = 58.75$ MHz, 84 dB μ V, CW
 $f_c = 55.17$ MHz, 74 dB μ V, CW
 $f_s = 54.25$ MHz, 74 dB μ V, CW } Input

Measure the difference of signal level at pin 24 920 kHz component and 3.58 MHz component (Chroma sub-carrier).

(Note 9) Suppression of picture career

(1) PIF input : $f_o = 58.75$ MHz, $f_m = 15.75$ kHz, 78%AM, 84 dB μ V
 Measure IF AGC voltage and supply that voltage from external source.

(2) Measure output video signal voltage. : V_1

(3) PIF input : $f_o = 58.75$ MHz, 84 dB μ V, CW
 Measure signal level of 58.75 MHz component at pin 24. : V_2
 Signal-noise ratio is calculated by following equality.

$$\text{Suppression of picture career} = 20 \times \log (V_1 / V_2) \text{ [dB]}$$

(Note 10) Output voltage at no signal

PIF input : no input IF AGC : GND
 Measure output video signal DC voltage.

(Note 11) Black noise inverter level / Black noise clamp level

PIF input : $f_o = 58.75$ MHz, $f_m = 15.75$ kHz, 78%AM, 84 dB μ V
 Supply 0V to IF AGC from external source. Raise that voltage gradually, measure black noise inverter level.

<SIF circuit>

(Note 12) Output signal voltage

SIF input : $f_o = 4.5 \text{ MHz}$, $f_m = 400 \text{ Hz}$, 25 kHz / devi , $84 \text{ dB}\mu\text{V}$
Measure output audio signal voltage.

(Note 13) SIF input signal voltage sensitivity

SIF input : $f_o = 4.5 \text{ MHz}$, $f_m = 400 \text{ Hz}$, 25 kHz / devi , $84 \text{ dB}\mu\text{V}$
Measure output audio signal voltage (that voltage is 0 dB). Lower input SIF signal voltage gradually, measure input SIF signal voltage when output audio signal voltage is -3 dB .

(Note 14) Total harmonic distortion

SIF input : $f_o = 4.5 \text{ MHz}$, $f_m = 400 \text{ Hz}$, 7.5 kHz / devi , $84 \text{ dB}\mu\text{V}$

(Note 15) AM Rejection

SIF input :

(1) FM : $f_o = 4.5 \text{ MHz}$, $f_m = 400 \text{ Hz}$, 25 kHz / devi , $84 \text{ dB}\mu\text{V}$

(2) AM : $f_o = 4.5 \text{ MHz}$, $f_m = 400 \text{ Hz}$, $30\% \text{ AM}$, $84 \text{ dB}\mu\text{V}$

Measure difference of output audio signal voltage between (1) and (2).

(Note 16) Signal-noise ratio

SIF input : $f_o = 4.5 \text{ MHz}$, $f_m = 400 \text{ Hz}$, 25 kHz / devi , $84 \text{ dB}\mu\text{V}$
Measure audio signal output voltage. : $V_1 \text{ [mV}_{\text{rms}}]$

SIF input : $f_o = 4.5 \text{ MHz}$, $f_m = 400 \text{ Hz}$, 25 kHz / devi , $84 \text{ dB}\mu\text{V}$
Measure audio signal output voltage. : $V_2 \text{ [mV}_{\text{rms}}]$
Signal-noise ratio is calculated by following equality.

$$\text{Signal-noise ratio} = 20 \log (V_1 / V_2) \text{ (dB)}$$

(Note 17) -3 dB bandwidth

SIF input : $f_o = 4.5 \text{ MHz}$, $f_m = 400 \text{ Hz}$, 25 kHz / devi , $84 \text{ dB}\mu\text{V}$
Measure audio signal output voltage. (that voltage is 0 dB) Then change input signal frequency, measure bandwidth that audio signal output voltage within -3 dB .

(Note 18) Dependence of output signal voltage on power supply voltage

SIF input : $f_o = 4.5 \text{ MHz}$, $f_m = 400 \text{ Hz}$, 25 kHz / devi , $84 \text{ dB}\mu\text{V}$
Measure the audio signal output voltage when power supply voltage are 3.5 V and 5.5 V . ($4.5 \pm 1.0 \text{ V}$)
Compare those voltage and audio signal output voltage when power supply voltage is 4.5 V .

TEST CIRCUIT 1 (DC CHARACTERISTIC)

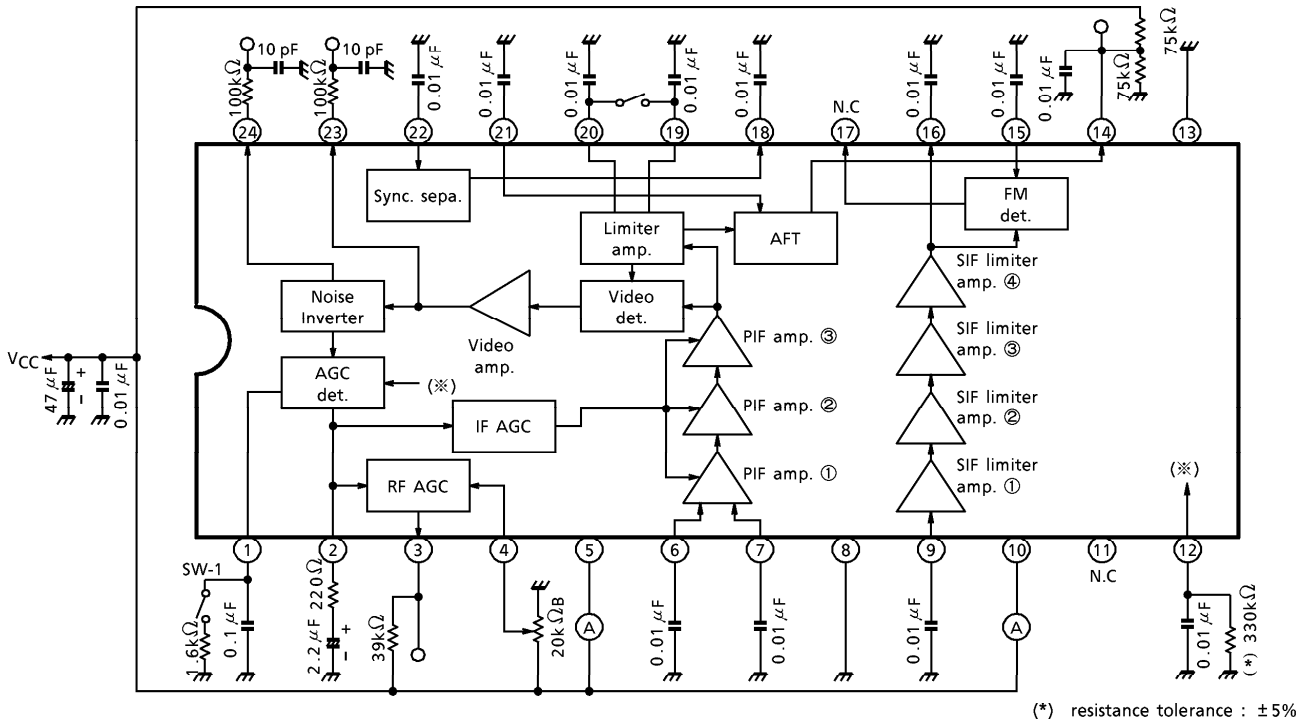

TEST CIRCUIT 2 (AC CHARACTERISTIC)

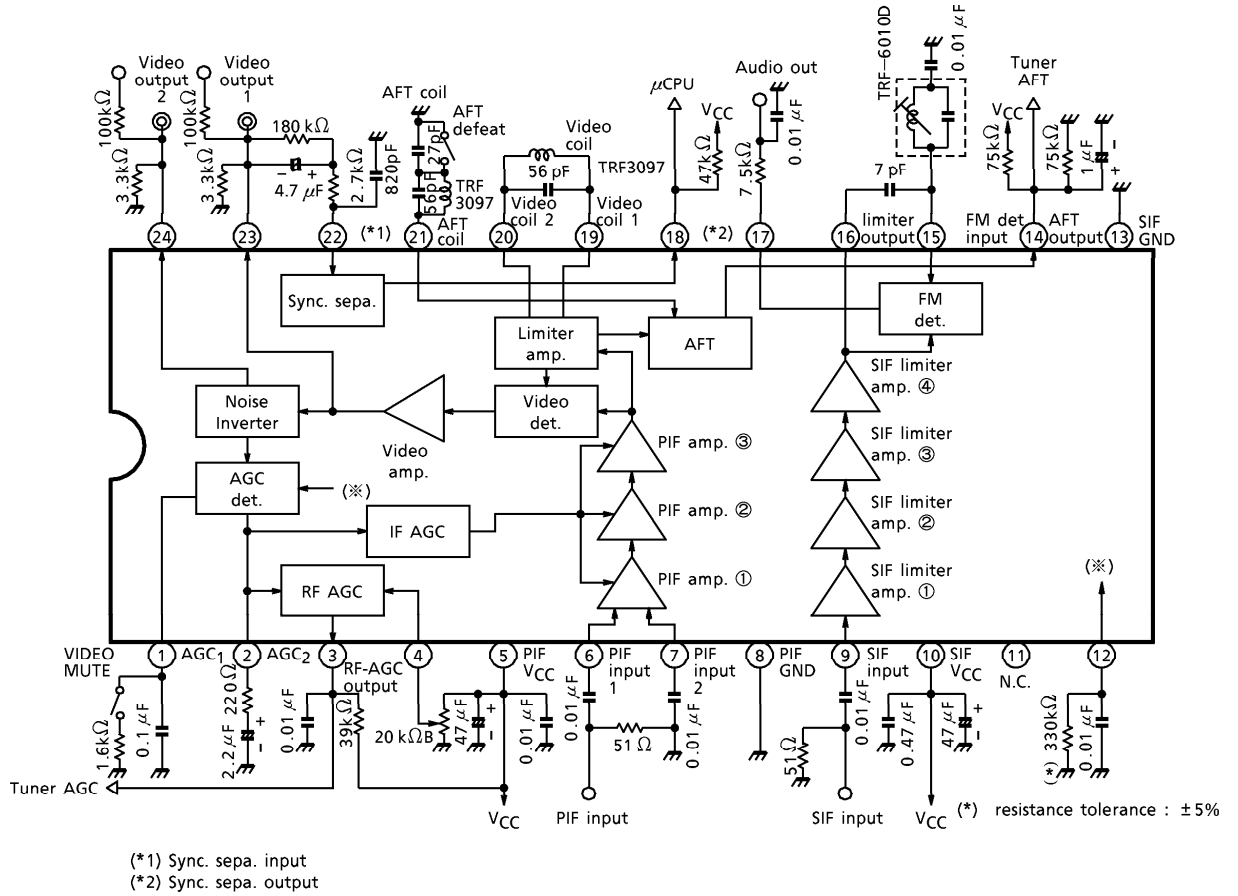

TEST CIRCUIT 3 (DG, DP)

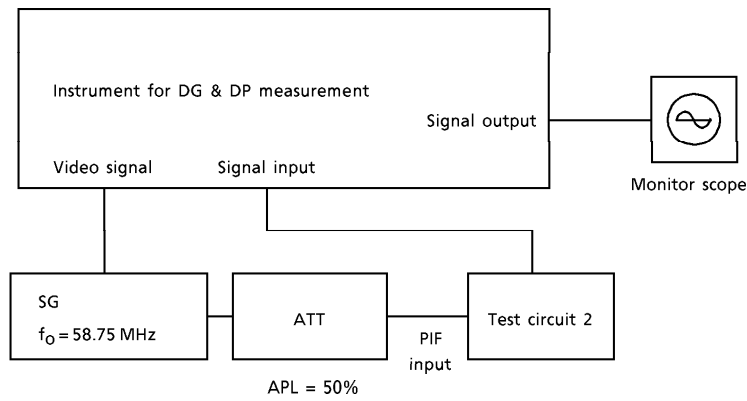

TEST CIRCUIT 4 (INTERMODULATION)

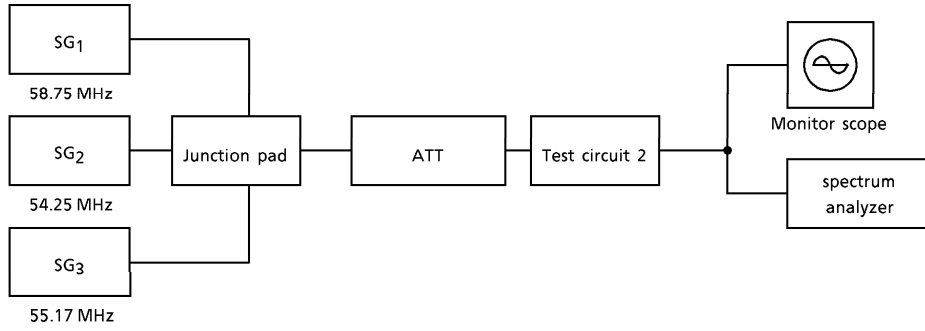

TEST CIRCUIT 5 (AMR)

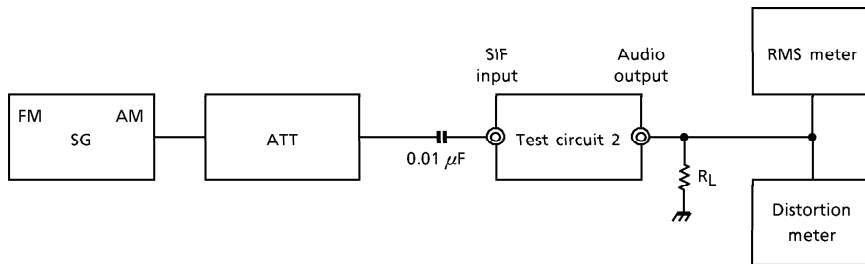

COIL ADJUSTMENT

● Video coil

Measure video signal output DC voltage.

IF AGC : Fix voltage for external voltage source /

PIF input : 58.75 MHz, 84 dB μ V, CW

Adjust video coil so that video signal output DC voltage is lowest.

● AFT coil

Measure video signal output AFT voltage.

PIF input : 54~62 MHz (sweep signal), 84 dB μ V

Adjust AFT coil so that AFT output signal is following figure.

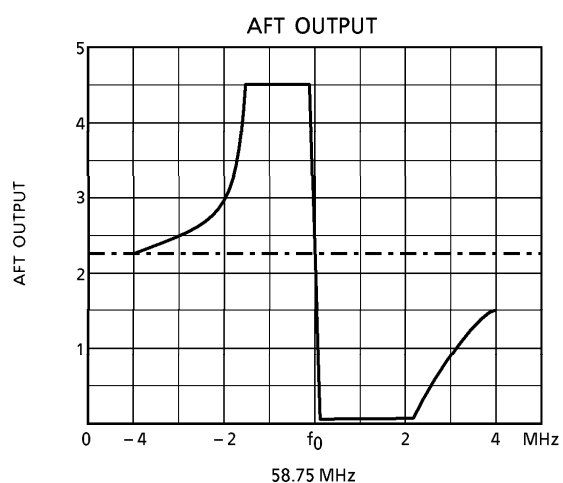

OUTLINE DRAWING
SSOP24-P-300-1.00

Unit : mm

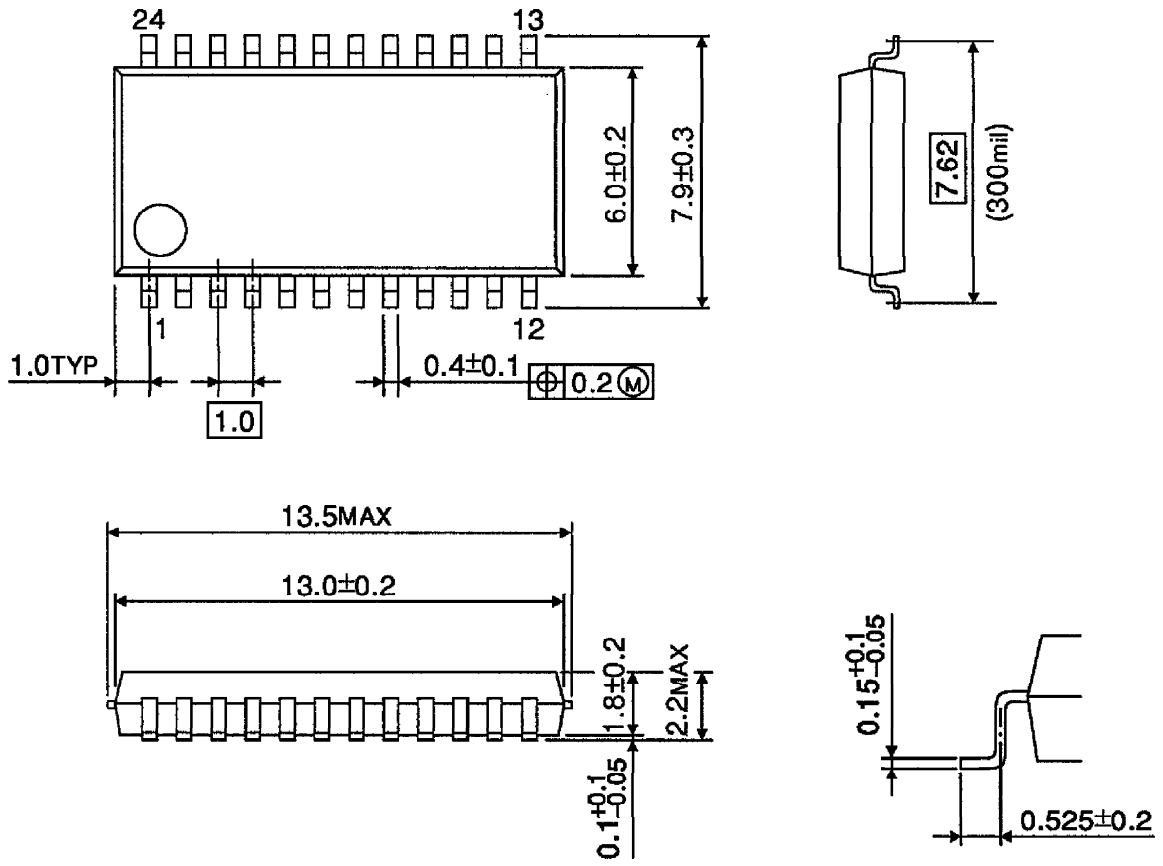

Weight : 0.32 g (Typ.)