

TOSHIBA

TA2003P/F

TOSHIBA BIPOLAR LINEAR INTEGRATED CIRCUIT SILICON MONOLITHIC

TA2003P, TA2003F

AM / FM RADIO IC

The TA2003P, TA2003F are AM/FM Radio IC (FM F/E + AM/FM IF) which are designed for AM/FM Radios. Combining with the TA7368P (Mono PW IC), a suitable AM/FM Radio System is able to be constituted.

FEATURES

- FM IFT, AM IFT and FM Detector Coil are not needed.
- Pin compatible of TA8164P.
- Operating Supply Voltage Range : $V_{CC(opr)} = 1.8 \sim 7V$ ($T_a = 25^\circ C$)

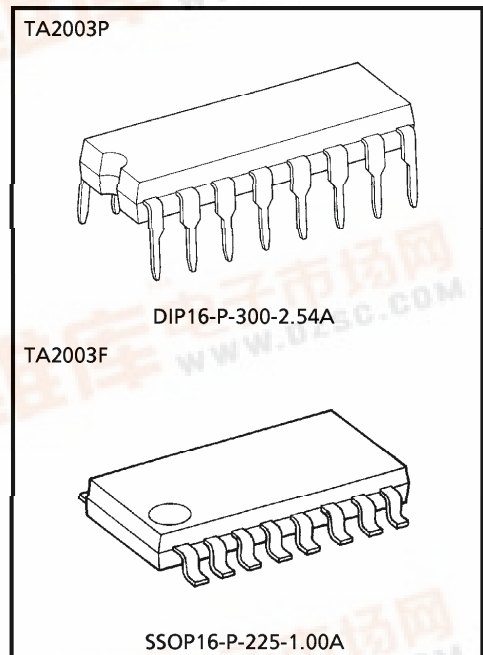

Weight
 DIP16-P-300-2.54A : 1.00g (Typ.)
 SSOP16-P-225-1.00A : 0.14g (Typ.)

980910EBA2

- TOSHIBA is continually working to improve the quality and the reliability of its products. Nevertheless, semiconductor devices in general can malfunction or fail due to their inherent electrical sensitivity and vulnerability to physical stress. It is the responsibility of the buyer, when utilizing TOSHIBA products, to observe standards of safety, and to avoid situations in which a malfunction or failure of a TOSHIBA product could cause loss of human life, bodily injury or damage to property. In developing your designs, please ensure that TOSHIBA products are used within specified operating ranges as set forth in the most recent products specifications. Also, please keep in mind the precautions and conditions set forth in the TOSHIBA Semiconductor Reliability Handbook.
- The products described in this document are subject to the foreign exchange and foreign trade laws.
- The information contained herein is presented only as a guide for the applications of our products. No responsibility is assumed by TOSHIBA CORPORATION for any infringements of intellectual property or other rights of the third parties which may result from its use. No license is granted by implication or otherwise under any intellectual property or other rights of TOSHIBA CORPORATION or others.
- The information contained herein is subject to change without notice.

BLOCK DIAGRAM

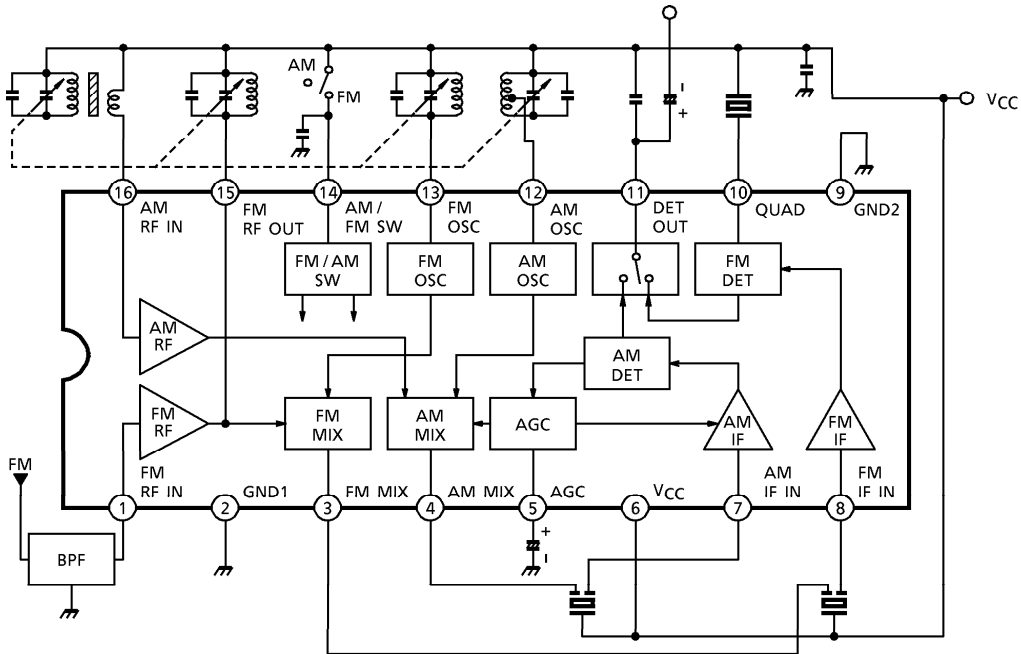

EXPLANATION OF TERMINAL

TERMINAL VOLTAGE : Typical DC voltage at Ta=25°C, VCC=3V and no signal with Test Circuit 1

PIN No.	SYMBOL	CONTENTS	INTERNAL CIRCUIT	TERMINAL VOLTAGE (V)	
				AM	FM
1	FM RF IN	Input of FM RF Amplifier		0	0.7
2	GND1	GND for RF, OSC and MIX Stage	—	0	0
3	FM MIX	Output of FM MIX		0.4	1.7
4	AM MIX	Output of AM MIX		0.6	0
5	AGC	By-pass of AM AGC		0	0
6	VCC	—	—	3.0	3.0

PIN No.	SYMBOL	CONTENTS	INTERNAL CIRCUIT	TERMINAL VOLTAGE (V)	
				AM	FM
7	AM IF IN	Input of AM IF Amplifier		3.0	3.0
8	FM IF IN	Input of FM IF Amplifier		3.0	3.0
9	GND2	GND for IF stage	—	0	0
10	QUAD	FM QUAD Detector Ceramic Discriminator is connected. Recommendation CDA10.7MG31 (MURATA MFG.CO., LTD)		2.5	2.2
11	DET OUT	Output of FM/AM Detector	<p> Ⓐ LOW→FM, HIGH→AM Ⓑ LOW→AM, HIGH→FM </p>	1.4	1.1
12	AM OSC	AM Local Oscillator Terminal Oscillator Coil is connected.		3.0	3.0

PIN No.	SYMBOL	CONTENTS	INTERNAL CIRCUIT	TERMINAL VOLTAGE (V)	
				AM	FM
13	FM OSC	FM Local Oscillator Terminal Oscillator Coil is connected.		0.9	3.0
14	AM / FM SW	AM / FM switch connected to Pin 14 VCC → FM mode Pin 14 OPEN → AM mode		0.9	3.0
15	FM RF OUT	FM RF Coil is connected.	cf. PIN ①	3.0	3.0
16	AM RF IN	Input of AM RF Amplifier		3.0	3.0

MAXIMUM RATINGS (Ta = 25°C)

CHARACTERISTIC		SYMBOL	RATING	UNIT
Supply Voltage		V _{CC}	8	V
Power Dissipation	DIP-16	P _D (Note)	750	mW
	SSOP-16		350	
Operating Temperature		T _{opr}	- 25~75	°C
Storage Temperature		T _{stg}	- 55~150	°C

(Note) Derated above Ta = 25°C in the proportion of 6mW/°C for TA2003P and of 2.8mW/°C for TA2003F.

ELECTRICAL CHARACTERISTICS

Unless otherwise specified, Ta = 25°C, V_{CC} = 3V, F/E : f = 98MHz, f_m = 1kHz
 FM IF : f = 10.7MHz, Δf = ± 22.5kHz, f_m = 1kHz
 AM : f = 1MHz, MOD = 30%, f_m = 1kHz

CHARACTERISTIC		SYMBOL	TEST CIRCUIT	TEST CONDITION	MIN.	TYP.	MAX.	UNIT
Supply Current		I _{CC} (FM)	1	FM mode, V _{in} = 0	—	10.5	16.5	mA
		I _{CC} (AM)	1	AM mode, V _{in} = 0	—	5.0	8.0	
F / E	Input Limiting Voltage	V _{in} (lim)	1	- 3dB limiting point	—	12	—	dB _μ V EMF
	Quiescent Sensitivity	Q _S	1	S / N = 30dB	—	12	—	dB _μ V EMF
	Local OSC Voltage	V _{OSC}	2	f _{OSC} = 108MHz	160	240	320	mV _{rms}
	Local OSC Stop Voltage	V _{stop} (FM)	2	V _{in} = 0	—	1.2	—	V
FM IF	Input Limiting Voltage	V _{in} (lim) IF	1	- 3dB limiting point	42	47	52	dB _μ V EMF
	Recovered Output Voltage	V _{OD}	1	V _{in} = 80dB _μ V EMF	50	70	90	mV _{rms}
	Signal To Noise Ratio	S / N	1	V _{in} = 80dB _μ V EMF	—	62	—	dB
	Total Harmonic Distortion	THD	1	V _{in} = 80dB _μ V EMF	—	0.4	—	%
	AM Rejection Ratio	AMR	1	V _{in} = 80dB _μ V EMF	—	33	—	dB
AM	Voltage Gain	G _V	1	V _{in} = 27dB _μ V EMF	15	32	50	mV _{rms}
	Recovered Output Voltage	V _{OD}	1	V _{in} = 60dB _μ V EMF	35	60	85	mV _{rms}
	Signal To Noise Ratio	S / N	1	V _{in} = 60dB _μ V EMF	—	43	—	dB
	Total Harmonic Distortion	THD	1	V _{in} = 60dB _μ V EMF	—	1.0	—	%
	Local OSC Stop Voltage	V _{stop} (AM)	1	V _{in} = 0	—	1.6	—	V

TEST CIRCUIT 1

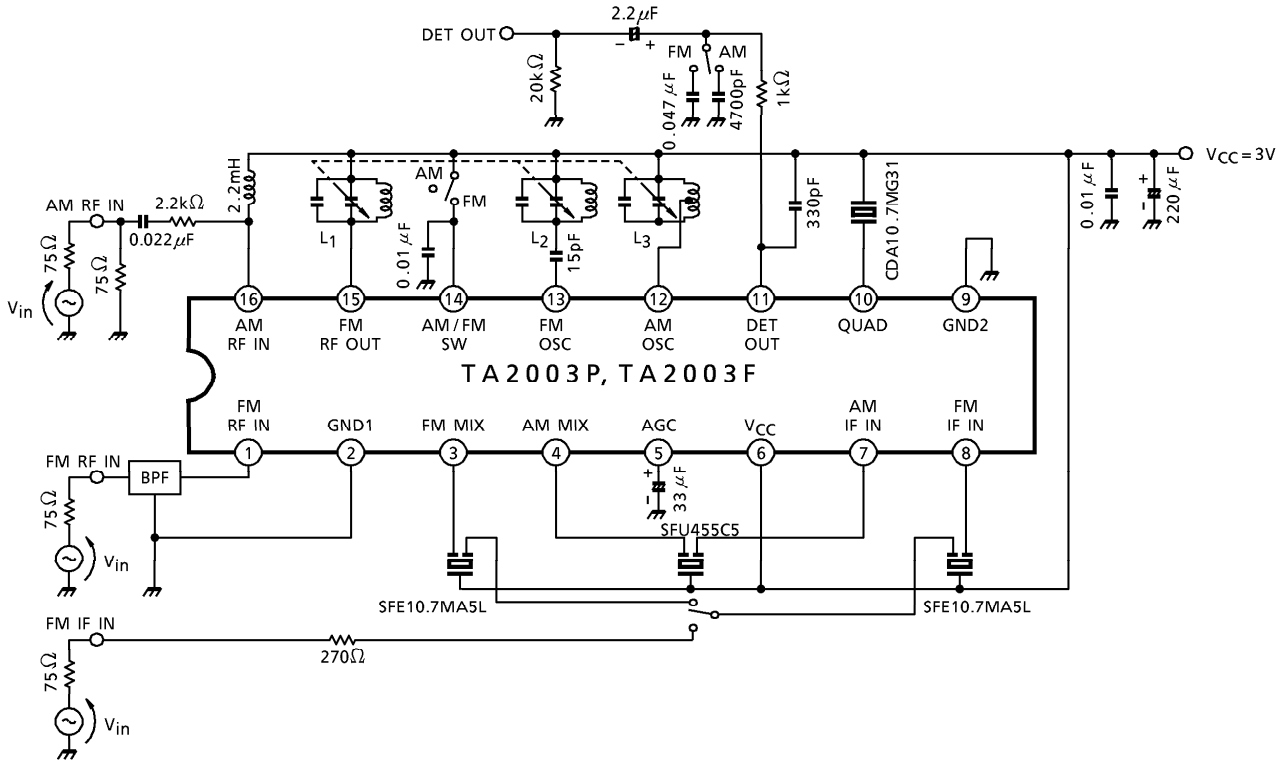

TEST CIRCUIT 2

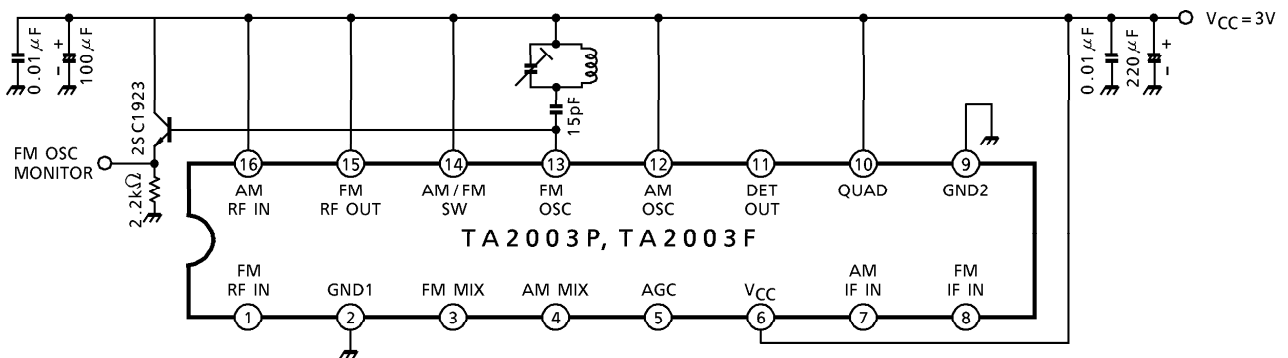

COIL DATA (Test circuit)

COIL No.	TEST FREQ. (Hz)	L (μ H)	C _o (pF)	Q _o	TURNS					WIRE (mm ϕ)	REFERENCE
					1-2	2-3	1-3	1-4	4-6		
L ₁ FM RF	100M	—	—	100	—	—	—	2 $\frac{1}{4}$	—	0.5 UEW	Ⓢ0258-000-021
L ₂ FM OSC	100M	—	—	100	—	—	1 $\frac{3}{4}$	—	—	0.5 UEW	Ⓢ0258-000-020
L ₃ AM OSC	796k	268	—	125	14	86	—	—	—	0.06 UEW	Ⓢ2157-2239-213A

Ⓢ : SUMIDA ELECTRIC CO., LTD.

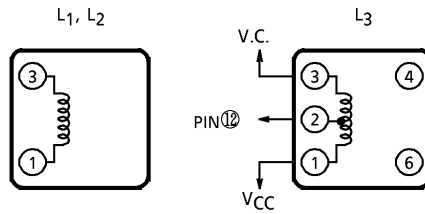

OUTLINE DRAWING
DIP16-P-300-2.54A

Unit : mm

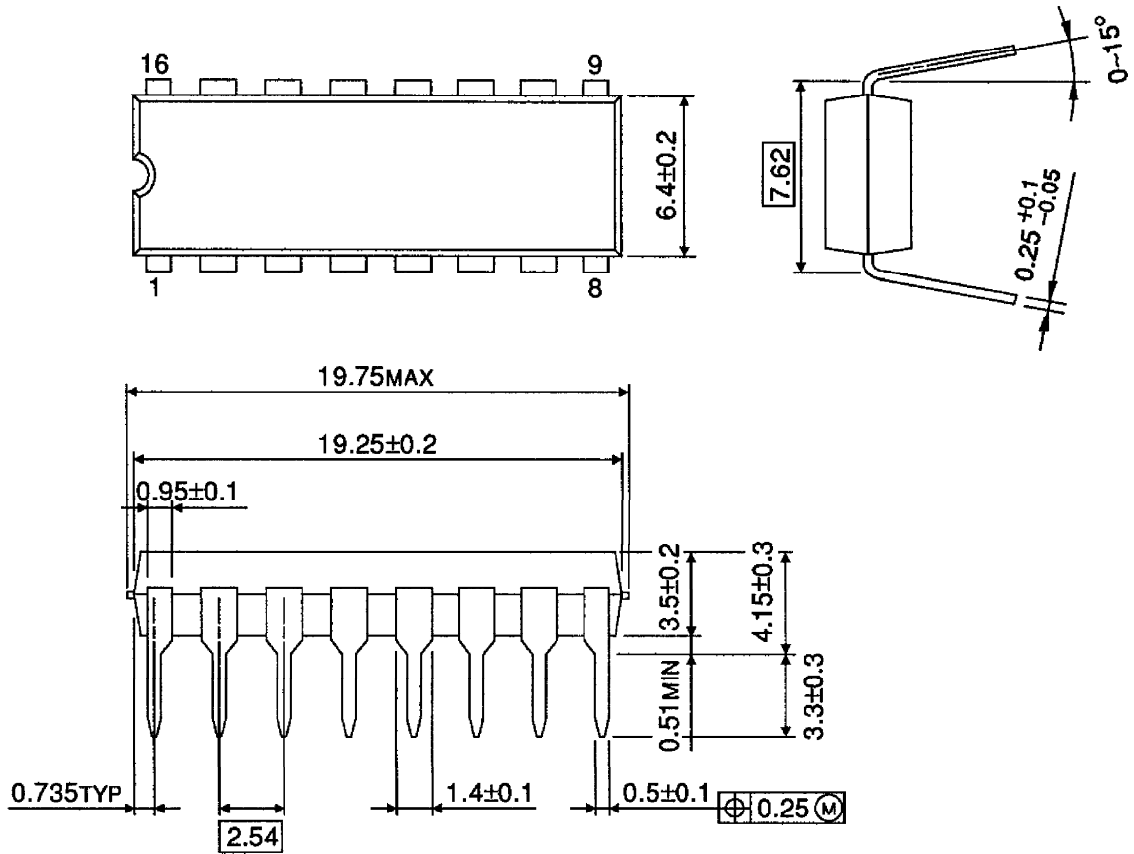

Weight : 1.00g (Typ.)

OUTLINE DRAWING
SSOP16-P-225-1.00A

Unit : mm

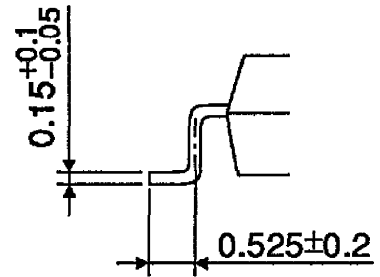
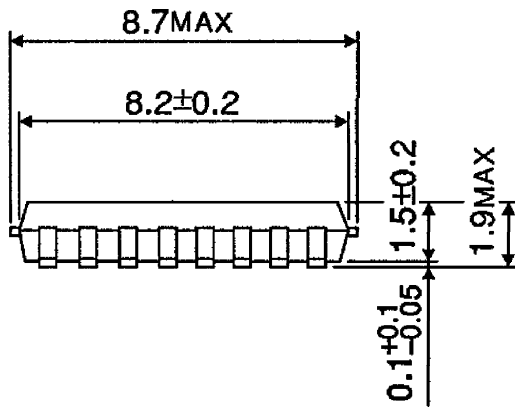
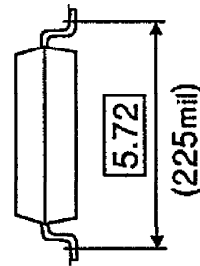
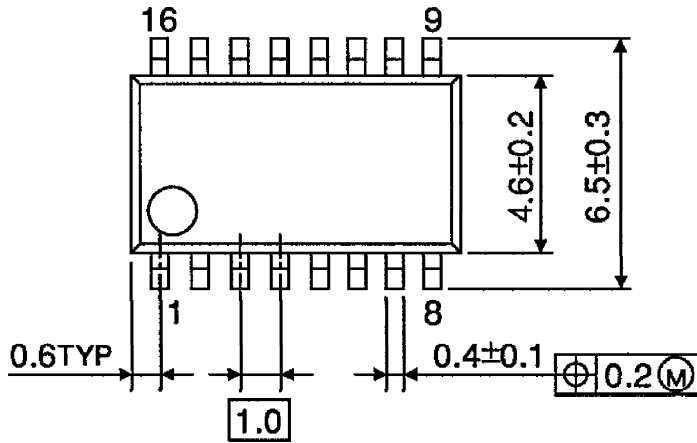

Weight : 0.14g (Typ.)