

TOSHIBA Bipolar Linear Integrated Circuit Silicon Monolithic

TA8132AN,TA8132AF,TA2012N,TA2012F

3V AM / FM IF + MPX
(For Digital Tuning System)

TA8132AN, TA8132AF and TA2012N, TA2012F are the AM / FM IF+ST DET system ICs, which are designed for DTS radios. These are included many functions and these can be used for digital tuning system with IF counter.

Features

- Built-in AM / FM IF and FM stereo PLL multiplex decoder.
- Suitable for combination with digital tuning system which is included IF counter.
 - One terminal type AM / FM IF count output (auto stop signal) for IF counter of digital tuning system.
 - FM: 10.7MHz or 1.3375MHz (1 / 8 dividing) changeable by external switch
 - AM: 450kHz
 - Built-in mute circuit for IF count output. It is controlled by the IF request signal from digital tuning system,
 - Pin(8) level: High → come out
 - Low → non output
 - Adjustable for IF count output sensitivity by external resistance of pin(2).
- For adopting ceramic discriminator and ceramic resonator, it is not necessary to adjust the FM quad detector circuit and FM ST DET VCO circuit.
- S curve characteristics of FM detection output in TA8132AN, TA8132AF and TA2012N, TA2012F are reverse to each other.
 - TA8132AN, TA8132AF: Reverse characteristic.
 - TA2012N, TA2012F: Normal characteristic.
- Built-in one terminal type AM low cut circuit.
- TA2053F is reverse pin type of TA2012F.
- Operating supply voltage range (Ta = 25°C)
 - VCC (opr.) = 1.8~8.0V

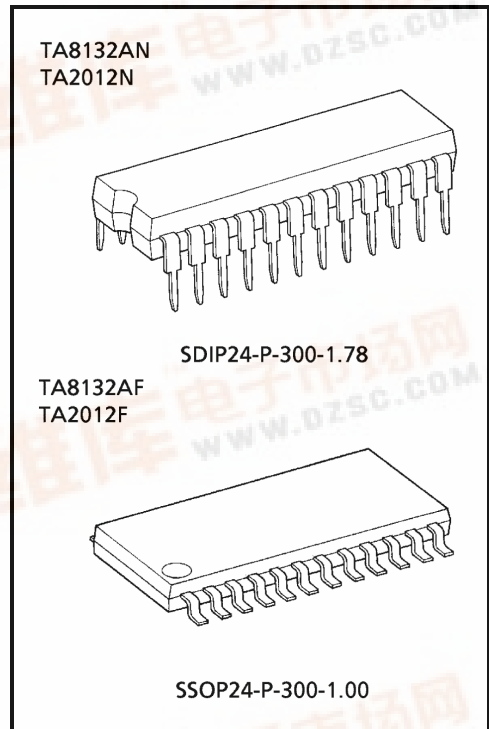

Weight
SDIP24-P-300-1.78: 1.2g (typ.)
SSOP24-P-300-1.00 : 0.31g (typ.)

Block Diagram

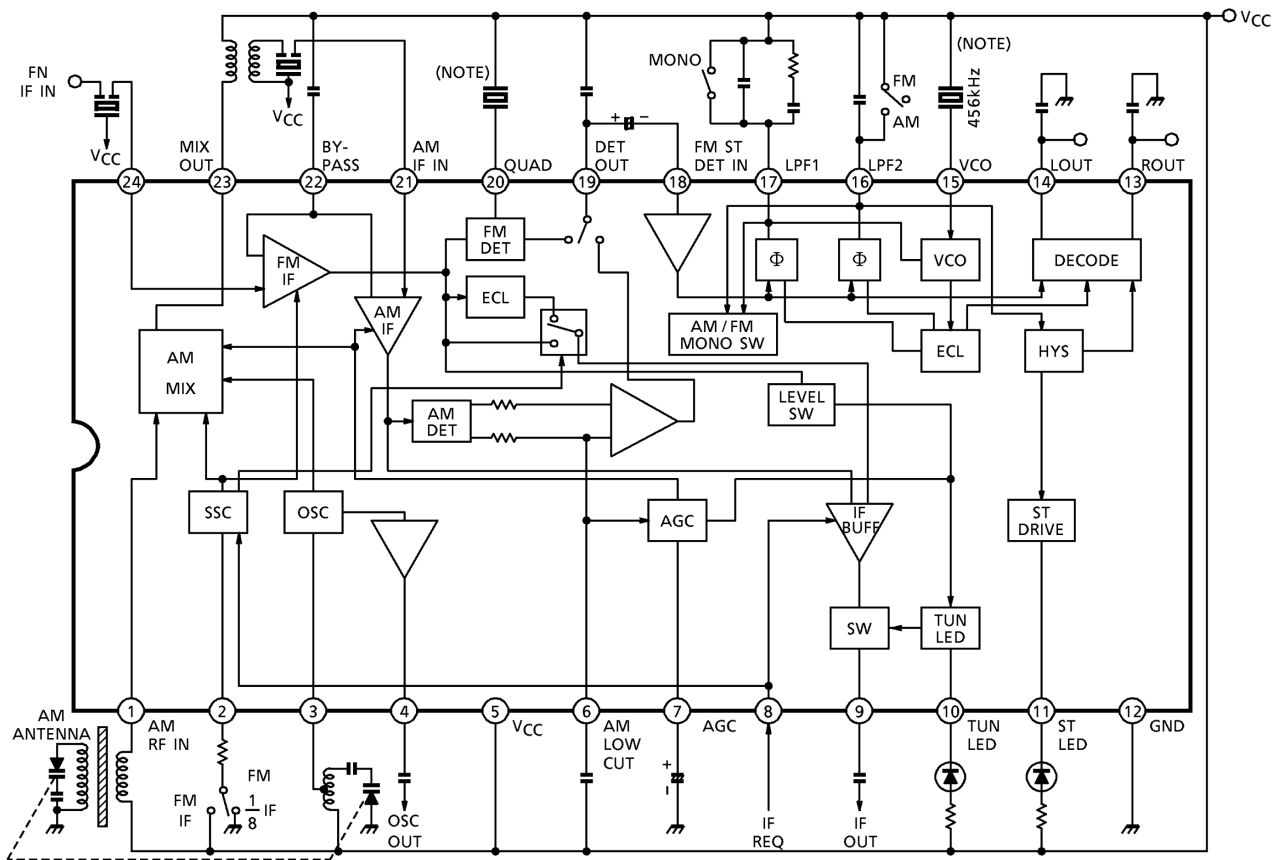

(Note)

We recommend

Ceramic resonator: CSB456F18

Ceramic discriminator: CDA10.7MG18 (MURATA MFG CO., LTD)

Explanation Of Terminals

Pin No.	Item	Internal Circuit	DC Voltage (V) (at no Signal)	
			AM	FM
1	AM RF IN		3.0	3.0
2	<ul style="list-style-type: none"> • IF count output sensitivity adjust terminal • FM IF divider control terminal 		—	—
3	AM OSC		3.0	3.0
4	AM OSC OUT		2.7	3.0
5	V _{CC}	—	3.0	3.0
6	AM LOW CUT		2.3	2.3

Pin No.	Item	Internal Circuit	DC Voltage (V) (at no Signal)	
			AM	FM
7	AGC		0.25	0.35
8	IF OUT SW		—	—
9	IF OUT		3.0	3.0
10	TUN LED (tuning LED)		—	—
11	ST LED (stereo LED)		—	—
12	GND	—	0	0
13 14	R-OUT L-OUT		1.0	1.0

Pin No.	Item	Internal Circuit	DC Voltage (V) (at no Signal)	
			AM	FM
15	VCO		2.5	2.5 (VCO stop mode)
16	LPF2 <ul style="list-style-type: none"> • LPF terminal for synchronous detector • Bias terminal for AM / FM switch circuit $V_{16} = V_{CC} \rightarrow \text{AM}$ $V_{16} = \text{open} \rightarrow \text{FM}$		3.0	2.2
17	LPF1 <ul style="list-style-type: none"> • LPF Terminal for phase detector • VCO stop terminal $V_{17} = V_{CC} \rightarrow \text{VCO stop}$		2.7	2.2
18	FM ST DET IN		0.7	0.7
19	DET OUT		1.1	1.1

Pin No.	Item	Internal Circuit	DC Voltage (V) (at no Signal)	
			AM	FM
20	QUAD (FM QUAD. Detector)		2.4	2.1
21	AM IF IN		3.0	3.0
22	BY-PASS By-pass for AM/FM IF AMP		2.3	2.8
23	AM MIX OUT		3.0	3.0
24	FM IF IN		3.0	3.0

Application Note

1. How to control the IF count output signal (pin(9) output)

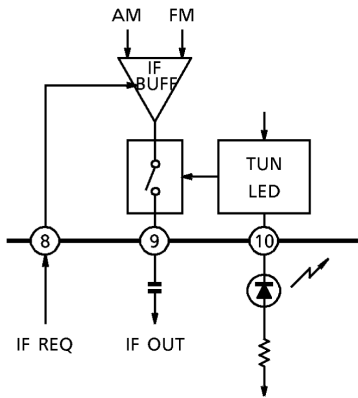

		TUN LED	
		ON	OFF
V ₈	H	Come out	Non output
	L	Non output	Non output

- Whether or not there is the IF count output signal (pin(9) output) is determined by the and of the pin(8) control voltage: V₈ and tuning LED on / off switching.

In the condition of

V₈: High (active high, V_{TH} = 0.8V (typ.))

TUN LED: ON (V_{in} ≥ V_L+2dBμV EMF (typ.))

the IF count output signal comes out from the pin(9).

In the case of the tuning LED function is not needed, it doesn't matter the pin(10) is opened.

- The output impedance of pin(9) is 1.5kΩ (typ.) (cf.P.4)
It is possible to reduce the IF count output signal level to add the resistance between the pin(9) and the VCC line.
- The signal waveform is the rectangular wave, and the level is 500mV_{p-p} (typ.)

2. How to control the divider of FM IF

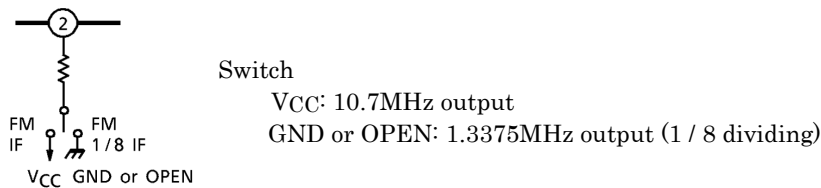

3. How to adjust the IF count output sensitivity

- The IF count output sensitivity (search sensitivity)
Can be adjusted by varying the IF AMP gain for FM and varying the MIXER gain for AM. This setting is made by changing the value of external resistance R₂ which is connected to pin(2).
- However, this is only possible at the auto-tuning mode. (external voltage supplied to pin(8) is at high level.)
The original again returns while receiving a broadcast station (supplied voltage to pin(8) is at low level.)

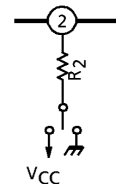

- The gain loss of FM IF AMP

		R ₂	
		0Ω	10KΩ (Note)
Mode	IF (10.7MHz)	-20dB	-1dB
	1 / 8 IF (1.3375MHz)	-20dB	-1dB

(Note)

- In the condition of the 1 / 8 IF mode, it is possible to set up R₂ = ∞ (OPEN).
- In the condition of IF mode, it is necessary to set up the value of R₂ under 10kΩ. When the R₂ is over 10kΩ it is feared that the mode is change to the 1 / 8 IF mode.

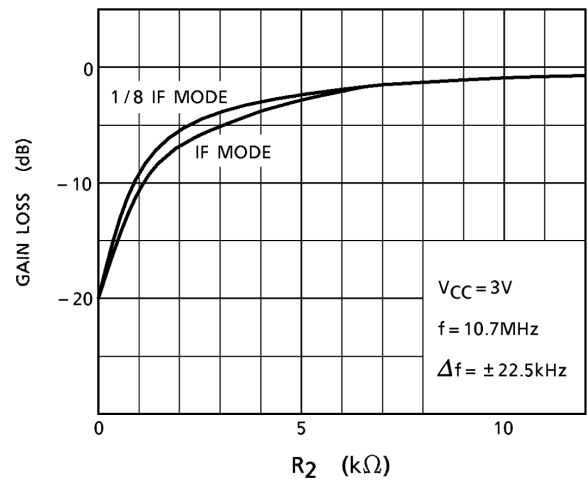

- The gain loss of AM MIXER

R ₂	
0Ω	10KΩ
-16dB	-1dB

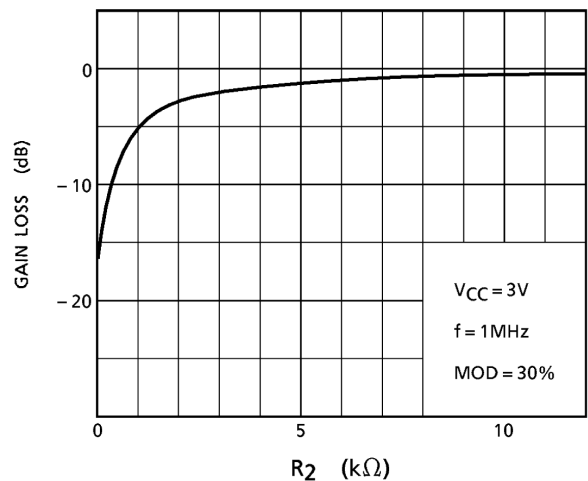

4. AM low-cut circuit

- The AM low-cut action is carried out by the bypass of the high frequency component of the positive-feedback signal at the AF AMP stage. The external capacitor: C₆ by-passes this component.
- The cut-off frequency f_L is determine by the internal resistance 22kΩ (typ.) and the external capacitor C₆ as following;

$$f_L = \frac{1}{2 \times \pi \times 22 \times 10^3 \times C_6} \text{ (Hz)}$$

- In the case of the AM low-cut function is not needed, set up the value of C₆ over 0.47μF. In the condition of C₆ ≥ 0.47μF, the frequency characteristic has flat response at the low frequency.

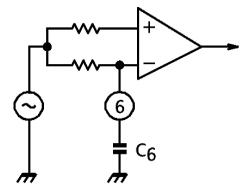

5. AM local oscillator buffer output

- The output impedance of AM local oscillator buffer output pin (pin(4)) is 750Ω (typ.) (cf.P.3)
- It is possible to reduce the output level to add the resistance between the pin(4) and VCC line. The signal waveform is the rectangular wave, and the level is 500mV_{p-p} (f_{OSC} = 1.45MHz, typ.)
- The higher local oscillation frequency (f_{OSC}) to be, the lower buff output level to be owing to the load capacity. So, in the case that it is connected to other circuits, take care of the input capacity of these circuits and stray capacity of wire.

6. Tuning LED driver and stereo LED driver

- The tuning LED driver and stereo LED driver don't have current limit resistance shown in the right figure. So, it is necessary to add the current limit resistance: R₁₀, R₁₁.
- Set up the values of R₁₀, R₁₁ to keep the drive currents I_{D10}, I_{D11} under 10mA.

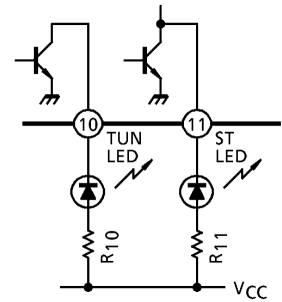

7.FM detection circuit

For the FM detection circuit,detection coil is able to use instead of ceramic discriminator.
 Recommended circuit and recommended coil are as follows.
 In this case, please take care that V_{in} (lim.) falls a little.

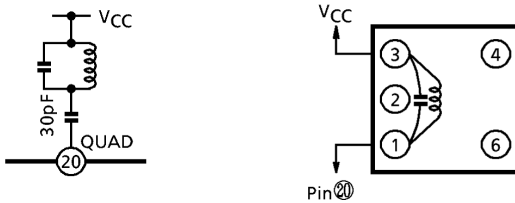

Test Frequency	C _o (pF)	Q _o	Turns				Wire (mmφ)	REF
			1-2	2-3	1-3	4-6		
10.7MHz	100	100	—	—	12	—	0.12 UEW	SUMIDA ELECTRIC CO., LTD 2153-4095-189 or equivalent

8. FM / AM switch and forced monaural switch

FM / AM switch over and stere / forced monaural switch over are done by internal PNP transistors ON / OFF which are connected to pin(16) and pin (17) respectively.

The threshold voltages of these PNP transistors are $V_{th} = V_{CC}$, and for switching, we recommend to use mechanical switch.

(Direct short to V_{CC} line.)

In the case of the electrical switch over by transistor, set up V_{CE} (saturation voltage between collector and emitter) 50mV or less, otherwise there are some cases that it does not become the AM mode and force monaural mode.

When these external switches are ON, the currents which flow into pin(16) and pin(17) are 100 μ A and 20 μ A respectively. (Typical value at $V_{CC} = 3V$)

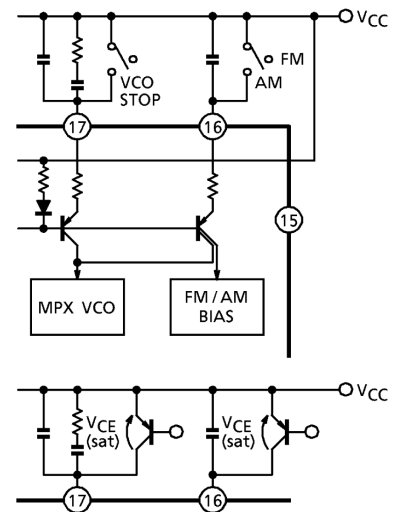

Maximum Ratings ($T_a = 25^\circ C$)

Characteristic	Symbol	Rating	Unit
Supply voltage	V_{CC}	8	V
LED current	I_{LED}	10	mA
LED voltage	V_{LED}	8	V
Power dissipation	TA8132AN	PD (Note)	mW
	TA8132AF		
Operating Temperature	T_{opr}	-25~75	$^\circ C$
Storage temperature	T_{stg}	-55~150	$^\circ C$

(Note): Derated above 25 $^\circ C$ in the proportion of 9.6mW / $^\circ C$ for TA8132AN, TA2012N and of 3.2mW / $^\circ C$ for TA8132AF, TA2012F.

Electrical characteristics

Unless Otherwise Specified, $T_a = 25^\circ\text{C}$, $V_{CC1} = 3\text{V}$, $SW_1 \rightarrow 10\text{k}\Omega$, $SW_3 \rightarrow \text{OFF}$
 FM IF: $f = 10.7\text{MHz}$, $\Delta f = \pm 22.5\text{kHz}$, $f_m = 1\text{kHz}$
 AM: $f = 1\text{MHz}$, $\text{MOD} = 30\%$, $f_m = 1\text{kHz}$
 MPX: $f_m = 1\text{kHz}$

Characteristic		Symbol	Test Circuit	Test Condition	Min.	Typ.	Max.	Unit	
Supply current		I_{CC} (FM)	1	FM mode, $V_{in} = 0$	—	11.0	14.0	mA	
		I_{CC} (AM)	1	AM mode, $V_{in} = 0$	—	10.5	13.5		
FM IF	Input limiting voltage	V_{in} (lim.)	1	-3dB limiting point	41	46	51	dB μ V EMF	
	Recovered output voltage	V_{OD}	1	$V_{in} = 80\text{dB}\mu\text{V}$ EMF	50	75	100		mV _{rms}
	Signal to noise ratio	S / N	1	$V_{in} = 80\text{dB}\mu\text{V}$ EMF	—	65	—	dB	
	Total harmonic distortion	THD	1	$V_{in} = 80\text{dB}\mu\text{V}$ EMF	—	0.2	—	%	
	AM rejection ratio	AMR	1	$V_{in} = 80\text{dB}\mu\text{V}$ EMF	—	38	—	dB	
	LED on sensitivity	V_L	1	$I_L = 1\text{mA}$	48	53	58	dB μ V EMF	
	IF count output frequency	IF	f_{IF} (FM)	1	$V_{in} = 80\text{dB}\mu\text{V}$ EMF, $SW_2 \rightarrow V_{CC}$, $SW_3 \rightarrow \text{ON}$	—	10.7		—
		1 / 8 IF	$f_{1/8 IF}$ (FM)	1	$V_{in} = 80\text{dB}\mu\text{V}$ EMF, $SW_2 \rightarrow \text{GND}$, $SW_3 \rightarrow \text{ON}$	1.3374	1.3375	1.3376	
	IF count output voltage	IF	V_{IF} (FM)	1	$V_{in} = 61\text{dB}\mu\text{V}$ EMF, $SW_2 \rightarrow V_{CC}$, $SW_3 \rightarrow \text{ON}$	350	500	—	mV _{p-p}
		1 / 8 IF	$V_{1/8 IF}$ (FM)	1	$V_{in} = 61\text{dB}\mu\text{V}$ EMF, $SW_2 \rightarrow \text{GND}$, $SW_3 \rightarrow \text{ON}$	350	500	—	
IF count output sensitivity		$I_{F\text{sens.}}$ (FM)	1	$SW_1 \rightarrow 0$, $SW_2 \rightarrow \text{GND}$, $SW_3 \rightarrow \text{ON}$	—	76	—	dB μ V EMF	
				$SW_1 \rightarrow 510\Omega$, $SW_2 \rightarrow \text{GND}$, $SW_3 \rightarrow \text{ON}$	—	68	—		
				$SW_1 \rightarrow 0$, $SW_2 \rightarrow V_{CC}$, $SW_3 \rightarrow \text{ON}$	—	77	—		
				$SW_1 \rightarrow 510\Omega$, $SW_2 \rightarrow V_{CC}$, $SW_3 \rightarrow \text{ON}$	—	69	—		

Characteristic		Symbol	Test Circuit	Test Condition	Min.	Typ.	Max.	Unit
AM	Gain	G_V	1	$V_{in} = 26\text{dB}\mu\text{V EMF}$	28	57	85	mV_{rms}
	Recovered output voltage	V_{OD}	1	$V_{in} = 60\text{dB}\mu\text{V EMF}$	50	75	100	
	Signal to noise ratio	S / N	1	$V_{in} = 60\text{dB}\mu\text{V EMF}$	—	41	—	dB
	Total harmonic distortion	THD	1	$V_{in} = 60\text{dB}\mu\text{V EMF}$	—	1.0	—	%
	LED on sensitivity	V_L	1	$I_L = 1\text{mA}$	21	26	31	$\text{dB}\mu\text{V EMF}$
	Local OSC buff. output voltage	$V_{OSC (AM)}$	1	$f_{OSC} = 1.45\text{MHz}$	350	500	—	$\text{mV}_{\text{p-p}}$
			2	$f_{OSC} = 27\text{MHz}$	—	500	—	
	IF count output voltage	$V_{IF (AM)}$	1	$V_{in} = 39\text{dB}\mu\text{V EMF}, SW_3 \rightarrow \text{ON}$	350	500	—	$\text{mV}_{\text{p-p}}$
IF count output sensitivity	$IF_{\text{sens. (AM)}}$	1	$SW_1 \rightarrow 0, SW_2 \rightarrow \text{GND}, SW_3 \rightarrow \text{ON}$	—	49	—	$\text{dB}\mu\text{V EMF}$	
			$SW_1 \rightarrow 510\Omega, SW_2 \rightarrow \text{GND}, SW_3 \rightarrow \text{ON}$	—	42	—		
			$SW_1 \rightarrow 0, SW_2 \rightarrow V_{CC}, SW_3 \rightarrow \text{on}$	—	49	—		
			$SW_1 \rightarrow 510\Omega, SW_2 \rightarrow V_{CC}, SW_3 \rightarrow \text{ON}$	—	42	—		
Pin(19) output resistance	R_{19}	1	FM mode	—	0.6	—	k Ω	
			AM mode	—	12	—		

Characteristic		Symbol	Test Circuit	Test Condition	Min.	Typ.	Max.	Unit		
MPX	Input resistance	R_{IN}	1	—	—	25	—	k Ω		
	Output resistance	R_{OUT}	1	—	—	5	—			
	Max. composite signal input voltage		$V_{in\ MAX}$ (stereo)	1	L + R = 90%, P = 10% THD = 3%, SW _g →LPF: ON	—	350	—	mV _{rms}	
	Separation		Sep	—	L + R = 135mV _{rms} P = 15mV _{rms} , SW _g →LPF: ON	$f_m = 100kHz$	—	42	—	dB
						$f_m = 1kHz$	35	42	—	
						$f_m = 10kHz$	—	42	—	
	Total harmonic distortion	Monaural	THD (monaural)	1	$V_{in} = 150\ mV_{rms}$ (mono)	—	0.2	—	%	
		Stereo	THD (stereo)		L + R = 135mV _{rms} , P = 15mV _{rms} , SW _g →LPF: ON	—	0.2	—		
	Voltage gain		G_V (MPX)	1	$V_{in} = 150mV_{rms}$ (mono)	-5	-3	-1	dB	
	Channel balance		C.B.	1	$V_{in} = 150mV_{rms}$ (mono)	-2	0	2	dB	
	Stereo LED sensitivity	ON	V_L (ON)	1	Pilot input	—	8	15	mV _{rms}	
		OFF	V_L (OFF)			2	6	—		
Stereo LED hysteresis		V_H	1	To LED turn off from LED turn on	—	2	—	mV _{rms}		
Capture range		C.R.	1	P = 15mV _{rms}	—	±1.3	—	%		
Signal to noise ratio		S / N	1	$V_{in} = 150mV_{rms}$ (mono)	—	78	—	dB		

Test Circuit 1

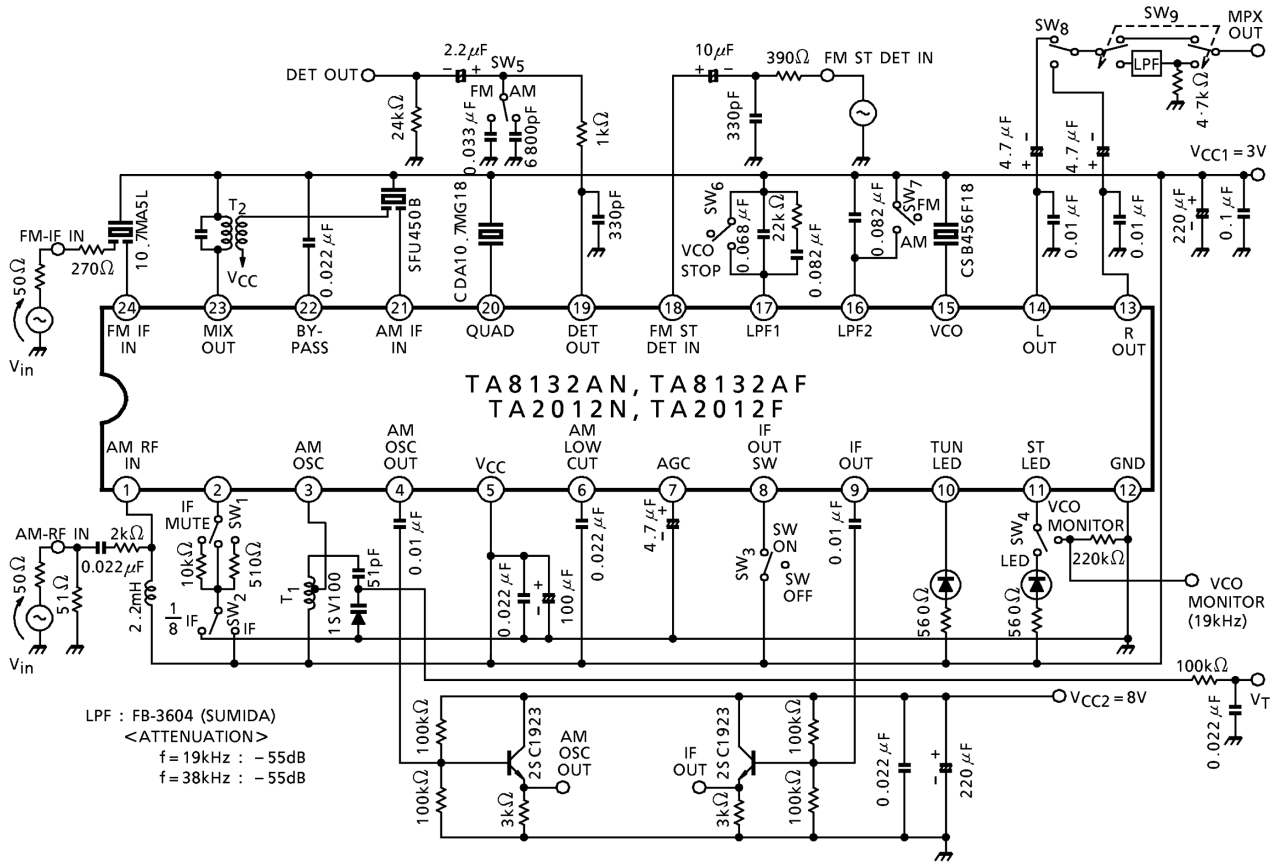

Coil Data (test circuit 1)

Coil No.	f	L (μH)	C ₀ (pF)	Q ₀	Turn				Wire (mm)	RED. (Coil No.)
					1-2	2-3	1-3	4-6		
T ₁ AM OSC	796kHz	288	—	115	13	73	—	—	0.08 UEW	4147-1356-038 (S)
T ₂ AM IFT	455KHz	—	180	120	—	—	180	15	0.06 UEW	2150-2162-165 (S)

(S): SUMIDA ELECTRIC Co., Ltd.

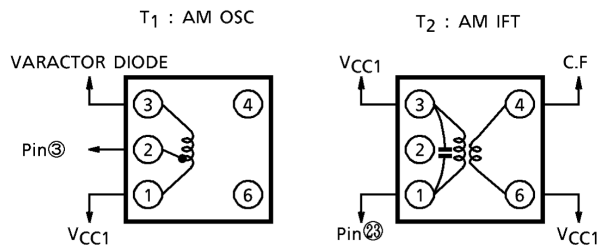

Test Circuit 2

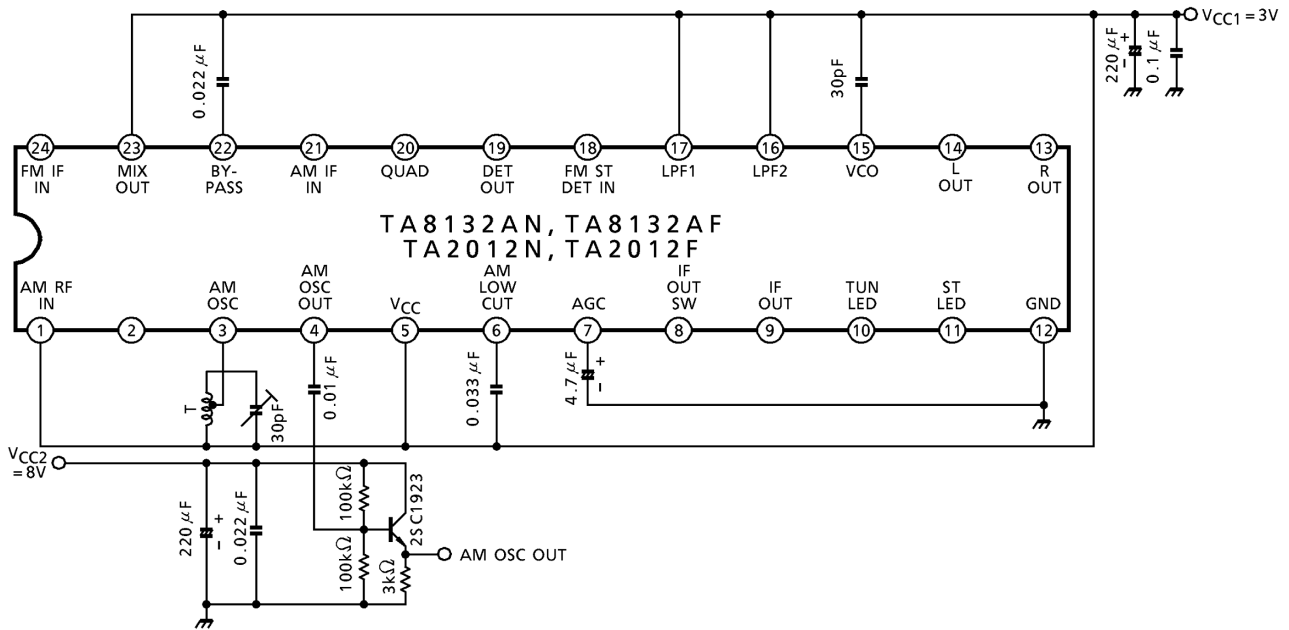

Coil Data (test circuit 2)

Coil No.	f	L (μ H)	C ₀ (pF)	Q ₀	Turn				Wire (mm)	REF. (Coil No.)
					1-2	2-3	1-3	4-6		
T AM OSC	7.96MHz	1.4	—	84	1	6	7	—	0.08 UEW	(T) 7PL-1344Y

(T): TOKO Co., Ltd.

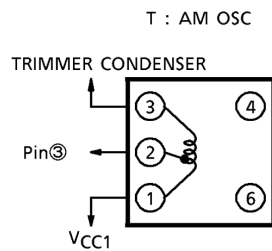

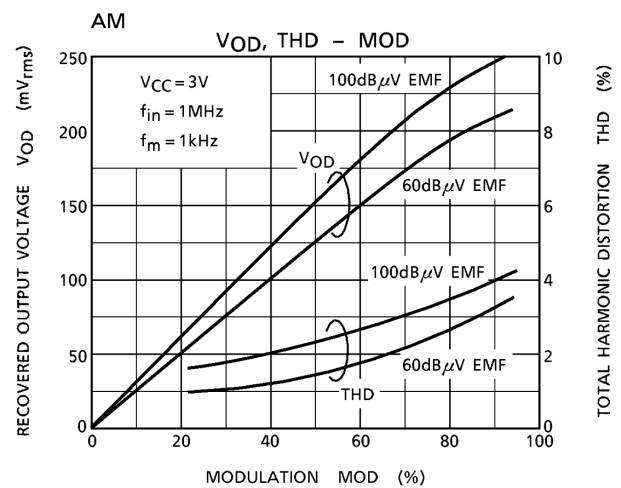
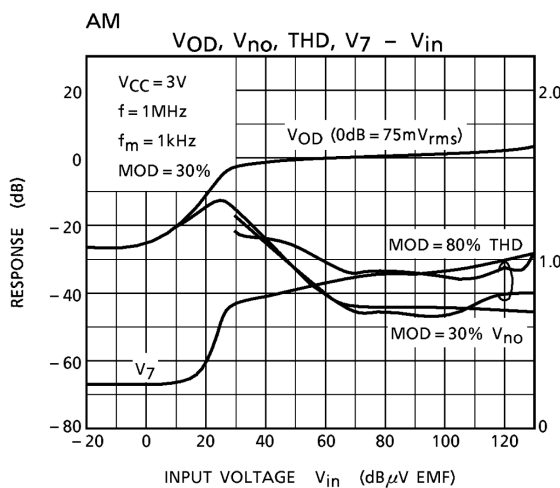
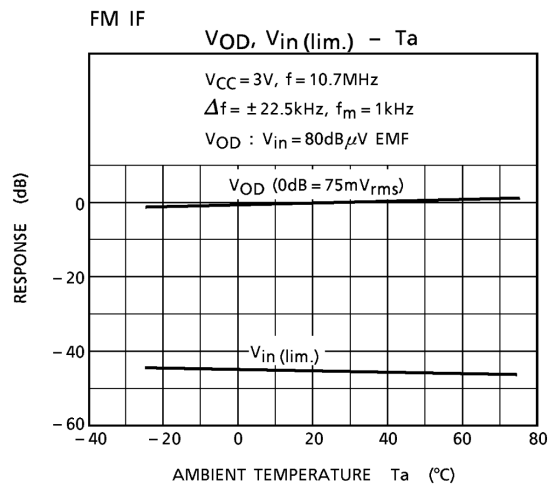
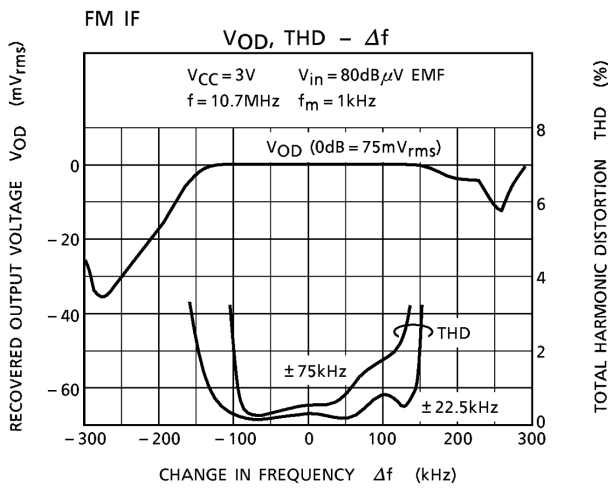
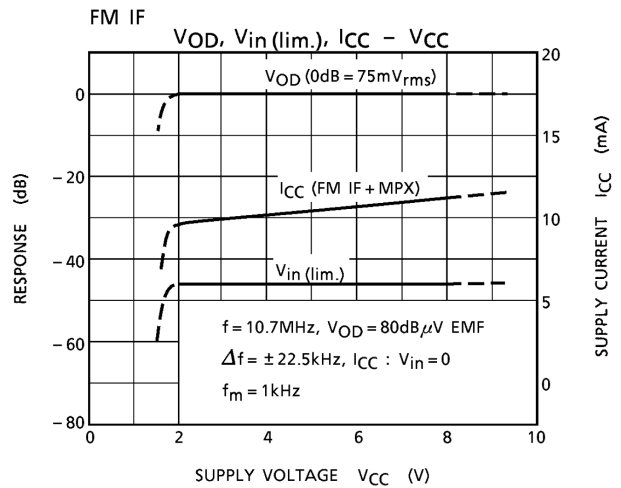
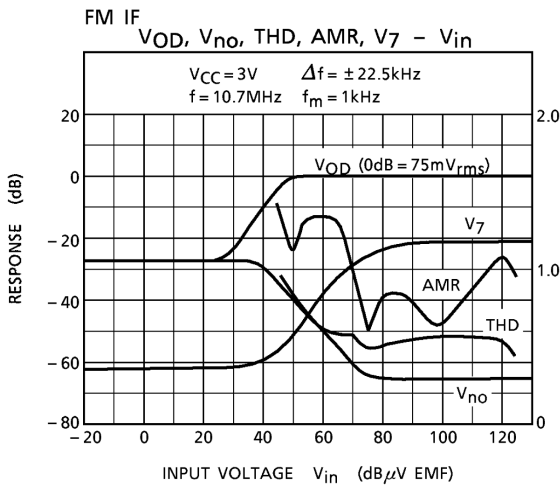

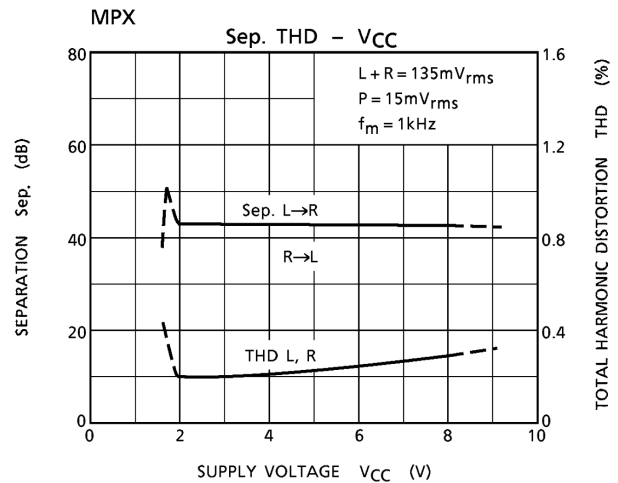
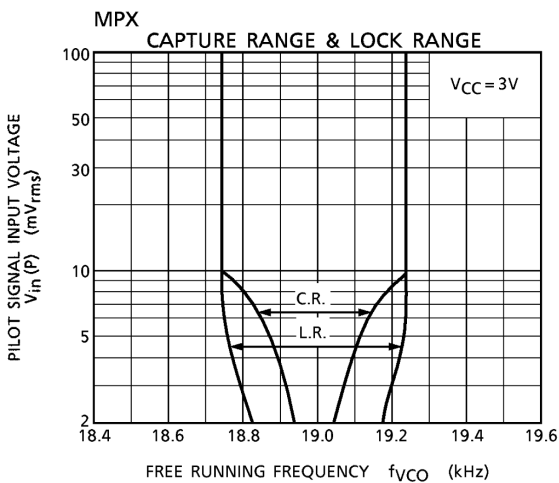
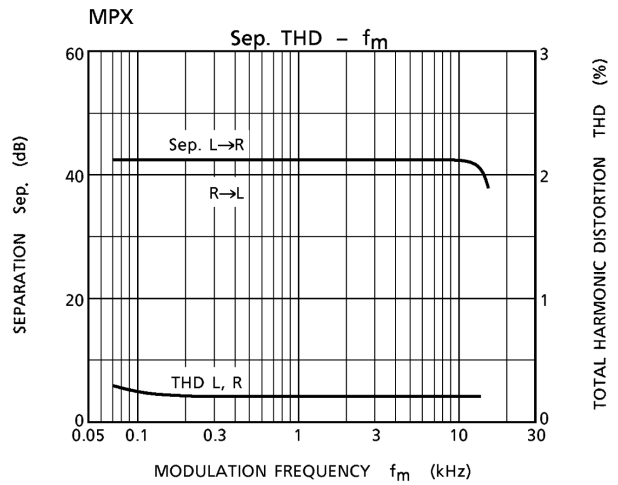
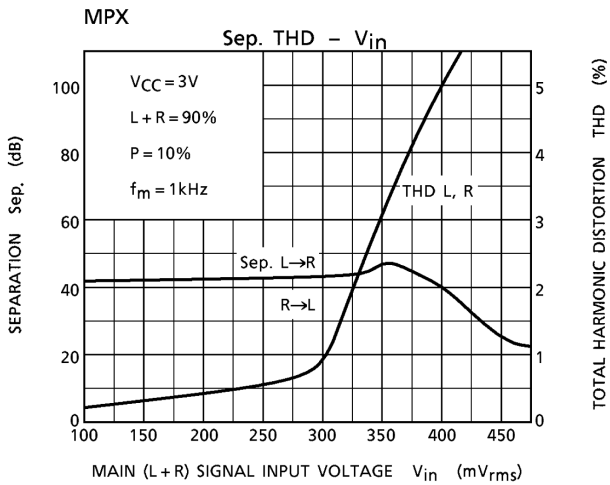
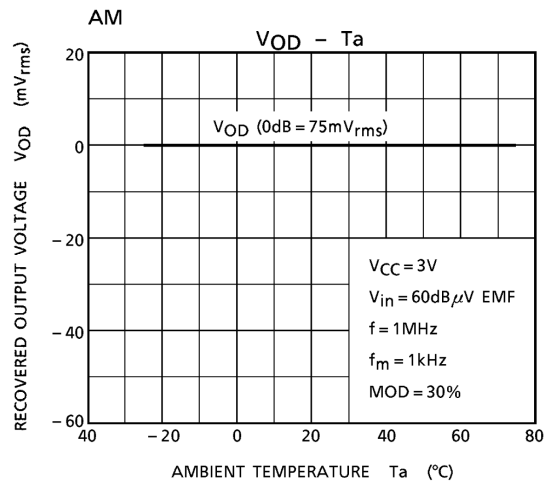
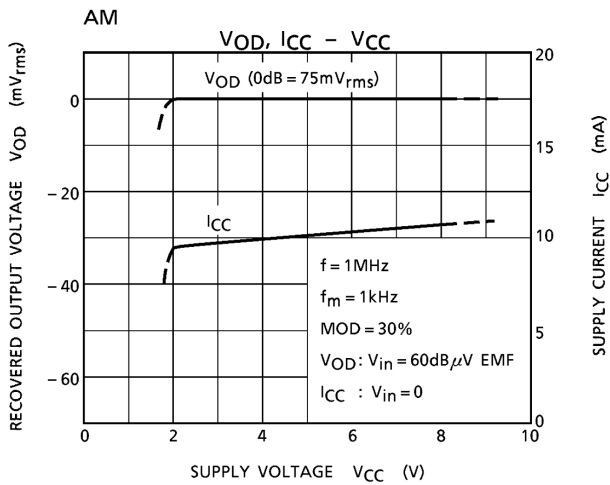

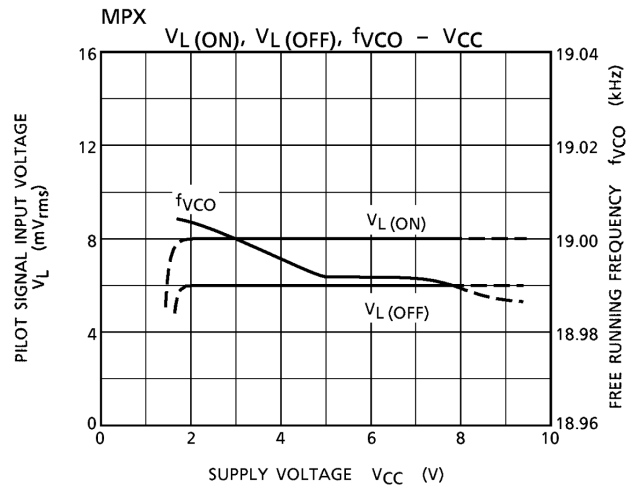
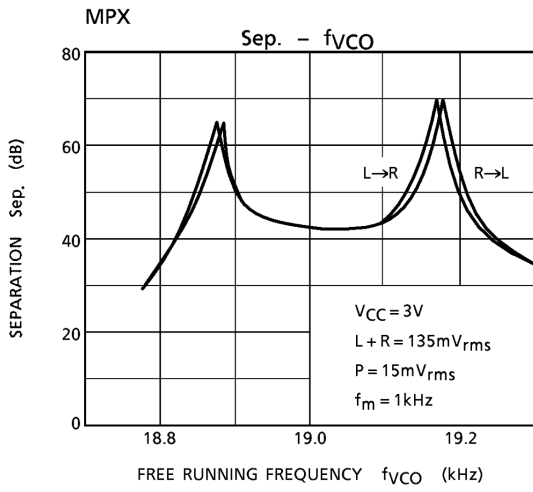

Package Dimensions

SDIP24-P-300-1.78

Unit : mm

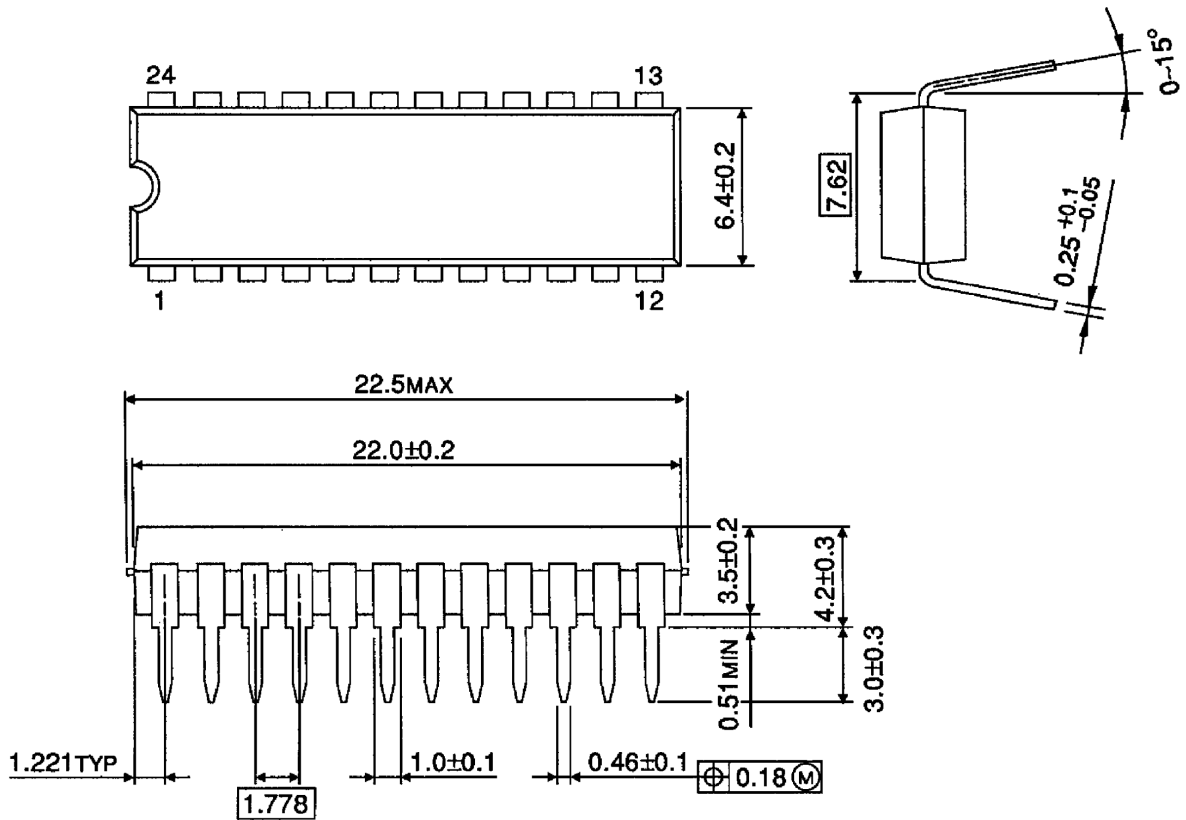

Weight: 1.2g (typ.)

Package Dimensions

SSOP24-P-300-1.00

Unit : mm

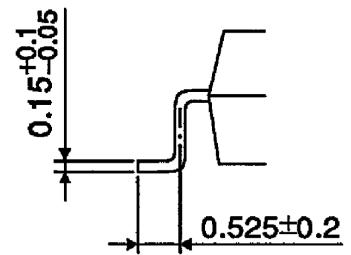
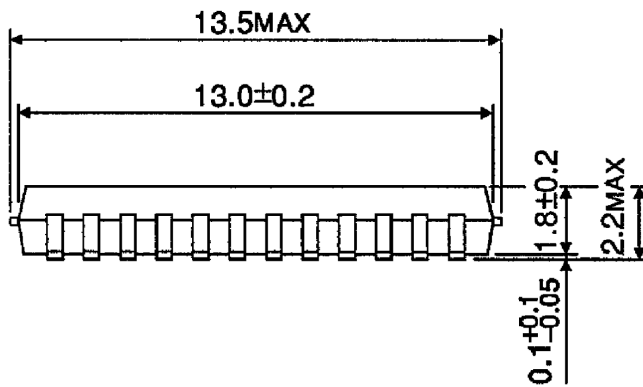
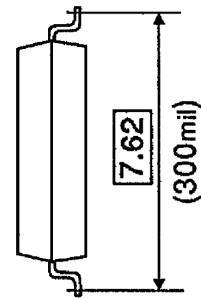
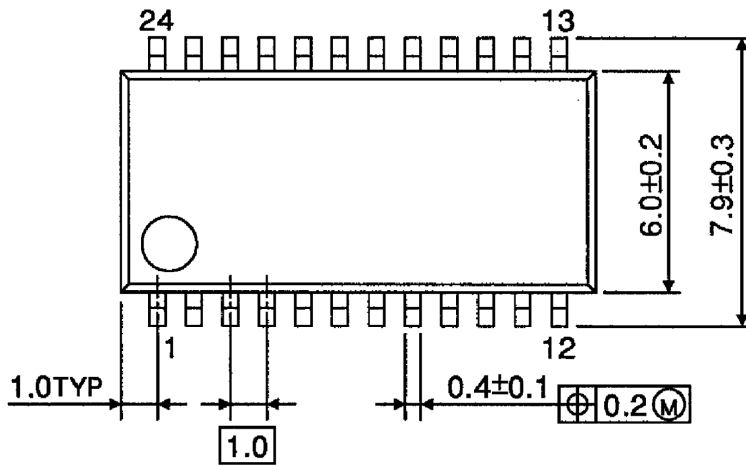

Weight: 0.31g (typ.)

RESTRICTIONS ON PRODUCT USE

000707EBA

- TOSHIBA is continually working to improve the quality and reliability of its products. Nevertheless, semiconductor devices in general can malfunction or fail due to their inherent electrical sensitivity and vulnerability to physical stress. It is the responsibility of the buyer, when utilizing TOSHIBA products, to comply with the standards of safety in making a safe design for the entire system, and to avoid situations in which a malfunction or failure of such TOSHIBA products could cause loss of human life, bodily injury or damage to property.
In developing your designs, please ensure that TOSHIBA products are used within specified operating ranges as set forth in the most recent TOSHIBA products specifications. Also, please keep in mind the precautions and conditions set forth in the "Handling Guide for Semiconductor Devices," or "TOSHIBA Semiconductor Reliability Handbook" etc..
- The TOSHIBA products listed in this document are intended for usage in general electronics applications (computer, personal equipment, office equipment, measuring equipment, industrial robotics, domestic appliances, etc.). These TOSHIBA products are neither intended nor warranted for usage in equipment that requires extraordinarily high quality and/or reliability or a malfunction or failure of which may cause loss of human life or bodily injury ("Unintended Usage"). Unintended Usage include atomic energy control instruments, airplane or spaceship instruments, transportation instruments, traffic signal instruments, combustion control instruments, medical instruments, all types of safety devices, etc.. Unintended Usage of TOSHIBA products listed in this document shall be made at the customer's own risk.
- The products described in this document are subject to the foreign exchange and foreign trade laws.
- The information contained herein is presented only as a guide for the applications of our products. No responsibility is assumed by TOSHIBA CORPORATION for any infringements of intellectual property or other rights of the third parties which may result from its use. No license is granted by implication or otherwise under any intellectual property or other rights of TOSHIBA CORPORATION or others.
- The information contained herein is subject to change without notice.