

TOSHIBA BIPOLAR LINEAR INTEGRATED CIRCUIT SILICON MONOLITHIC

TA2068N

SYSTEM PREAMPLIFIER FOR SINGLE CASSETTE DECK

The TA2068N is system preamplifier IC for single deck radio-cassette tape player.

This IC have built-in function for single cassette deck and mixing amp for KARAOKE and Function switch for source selector.

FEATURES

- Dual Channel
- Built-in EQ Amp, REC Amp, Monitor Amp, Mic (Mixing) Amp
- Mic Amp is suitable for both inner mic and mixing mic.
- Built-in source selector switch ; RADIO-IN / TAPE-IN / AUX-IN
- 6-operation mode are available for INNER MIC set and MIXING MIC set.

<Inner MIC set>

- 1) TAPE PLAY-BACK
- 2) LINE-IN PLAY
- 3) RADIO PLAY
- 4) MIC RECORDING without MONITOR
- 5) LINE-IN RECORDING AND PLAY
- 6) RADIO RECORDING AND PLAY

<Mixing MIC set>

- 1) TAPE PLAY-BACK with MIC MIXING
- 2) LINE-IN PLAY with MIC MIXING
- 3) RADIO PLAY with MIC MIXING
- 4) MIC RECORDING with MONITOR
- 5) LINE-IN RECORDING AND PLAY with MIC MIXING
- 6) RADIO RECORDING AND PLAY with MIC MIXING

- Operating Supply Voltage Range
: $V_{CC}(\text{opr}) = 4.0 \sim 9.0\text{V}$ ($T_a = 25^\circ\text{C}$)

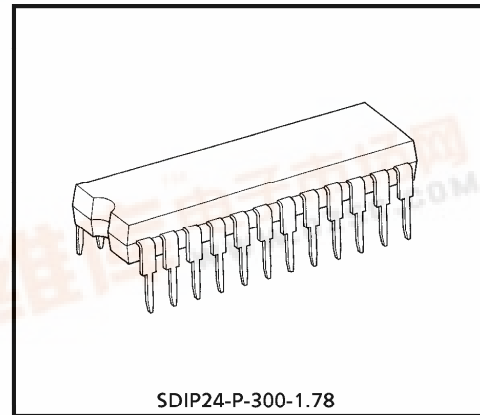

Weight : 1.2g (Typ.)

961001EBA2

- TOSHIBA is continually working to improve the quality and the reliability of its products. Nevertheless, semiconductor devices in general can malfunction or fail due to their inherent electrical sensitivity and vulnerability to physical stress. It is the responsibility of the buyer, when utilizing TOSHIBA products, to observe standards of safety, and to avoid situations in which a malfunction or failure of a TOSHIBA product could cause loss of human life, bodily injury or damage to property. In developing your designs, please ensure that TOSHIBA products are used within specified operating ranges as set forth in the most recent products specifications. Also, please keep in mind the precautions and conditions set forth in the TOSHIBA Semiconductor Reliability Handbook.
- The products described in this document are subject to foreign exchange and foreign trade control laws.
- The information contained herein is presented only as a guide for the applications of our products. No responsibility is assumed by TOSHIBA CORPORATION for any infringements of intellectual property or other rights of the third parties which may result from its use. No license is granted by implication or otherwise under any intellectual property or other rights of TOSHIBA CORPORATION or others.
- The information contained herein is subject to change without notice.



BLOCK DIAGRAM

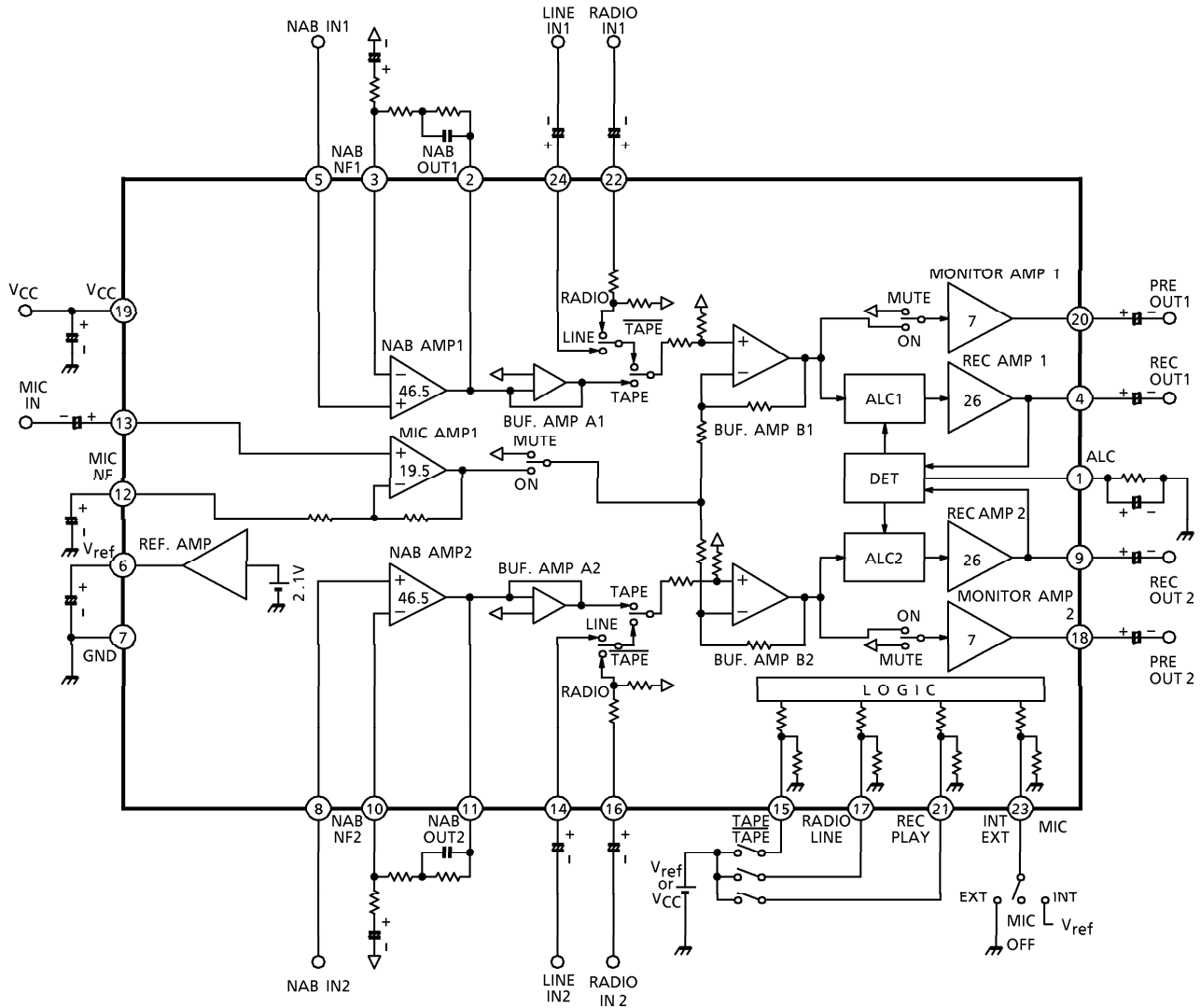

TERMINAL EXPLANATION

TERMINAL No.	SYMBOL	FUNCTION	EQUIVALENT CIRCUIT
1	ALC	Automatic level Control time constant terminal	
2 / 11	NAB OUT	Playback Amp output	
3 / 10	NAB NF	Playback Amp NF	
4 / 9	REC OUT	Recording Amp output	

TERMINAL No.	SYMBOL	FUNCTION	EQUIVALENT CIRCUIT
5/8	NAB IN	Playback Amp input	
6	V _{ref}	Reference voltage	
7	GND	GND terminal	—
12	MIC NF	MIC Amp NF	
16/22	RADIO IN	Radio input terminal	

TERMINAL No.	SYMBOL	FUNCTION	EQUIVALENT CIRCUIT
18/20	PRE OUT	MONITOR Amp output	
13	MIC IN	MIC Amp input	
14/24	LINE IN	Line input	
15	TAPE / $\overline{\text{TAPE}}$ SW	TAPE / EXTERNAL INPUT function SW	
17	LINE / RADIO SW	LINE / RADIO INPUT function SW	
21	REC / PLAY SW	PLAYBACK / RECORDING function SW	
23	INT / MIC OFF / EXT	INTERNAL MIC / MIC OFF / EXTERNAL MIC function SW	

SWITCH MODE EXPLANATION

FUNCTION			SWITCH MODE COMBINATION				INPUT	INPUT RESISTANCE R _g	OUTPUT AMPLIFIER
			SW ₄	SW ₃	SW ₂	SW ₁			
RADIO Mode	Play-back	(*) W.O V _{no} , R.R.	L/O	O/H	H	O	RADIO	—	MONITOR
		V _{no11}	O	O/H	H	O	—	RADIO	MONITOR
		V _{no12}	L	O/H	H	O	—	RADIO / MIC	MONITOR
		R.R.11	O	O/H	H	O	—	RADIO	MONITOR
		R.R.12	L	O/H	H	O	—	RADIO / MIC	MONITOR
	REC	(*) W.O V _{no} , R.R.	L/O	H	H	O	RADIO	—	REC
		V _{no21}	O	H	H	O	—	RADIO	REC
		V _{no22}	L	H	H	O	—	RADIO / MIC	REC
		R.R.21	O	H	H	O	—	RADIO	REC
		R.R.22	L	H	H	O	—	RADIO / MIC	REC
LINE Mode	Play-back	(*) W.O V _{no} , R.R.	L/O	O/H	O	O	LINE	—	MONITOR
		V _{no31}	O	O/H	O	O	—	LINE	MONITOR
		V _{no32}	L	O/H	O	O	—	LINE / MIC	MONITOR
		R.R.31	O	O/H	O	O	—	LINE	MONITOR
		R.R.32	L	O/H	O	O	—	LINE / MIC	MONITOR
	REC	(*) W.O V _{no} , R.R.	L/O	H	O	O	LINE	—	REC
		V _{no41}	O	H	O	O	—	LINE	REC
		V _{no42}	L	H	O	O	—	LINE / MIC	REC
		R.R.41	O	H	O	O	—	LINE	REC
		R.R.42	L	H	O	O	—	LINE / MIC	REC
TAPE Mode	(*) W.O V _{no} , R.R.	L/O	O	O/H	H	TAPE	—	MONITOR	
	V _{no51}	O	O	O/H	H	—	TAPE	MONITOR	
	V _{no52}	L	O	O/H	H	—	TAPE / MIC	MONITOR	
	R.R.51	O	O	O/H	H	—	TAPE	MONITOR	
	R.R.52	L	O	O/H	H	—	TAPE / MIC	MONITOR	
MIC Mode	Play-back	(*) W.O V _{no} , R.R.	L	H	O/H	H	MIC	—	MONITOR
		V _{no6}	L	H	O/H	H	—	MIC	MONITOR
		R.R.61	O	H	O/H	H	—	MIC	MONITOR
		R.R.62	L	H	O/H	H	—	MIC	MONITOR
	REC	(*) W.O V _{no} , R.R.	L/O	H	O/H	H	MIC	—	REC
		V _{no7}	L/O	H	O/H	H	—	MIC	REC
		R.R.7	L/O	H	O/H	H	—	MIC	REC

L : GND
 O : OPEN
 H : V_{CC}

(*) W.O = WITHOUT

OPERATION MODE BY EXTERNAL SWITCH (1/2)

SW POSITION		V _{ref} INTERNAL MIC MODE				GND EXTERNAL MIC MODE			
MIC MODE	G : EXT MIC O : MIC OFF H : INT MIC	OPEN PLAY BACK MODE	VCC RECORDING MODE	OPEN PLAY BACK MODE	VCC RECORDING MODE	OPEN PLAY BACK MODE	VCC RECORDING MODE	OPEN PLAY BACK MODE	VCC RECORDING MODE
REC/PLAY	SW ₃ (21) O : PLAY H : REC	VCC	OPEN	VCC	OPEN	VCC	OPEN	VCC	OPEN
SOURCE SELECT	SW ₂ (15) O : TAPE H : TAPE	VCC	OPEN	VCC	OPEN	VCC	OPEN	VCC	OPEN
	SW ₁ (17) O : LINE H : RADIO	VCC	OPEN	VCC	OPEN	VCC	OPEN	VCC	OPEN
OPERATION MODE	INPUT/SOURCE	TAPE	LINE	RADIO	MIC	LINE	RADIO	LINE	RADIO
	MONITOR OUT	○	○	○	○	○	○	○	○
	REC OUT	○	○	○	○	○	○	○	○
INTERNAL OPERATION	NAB AMP	ON	ON	OFF	OFF	ON	ON	OFF	OFF
	BUFFER AMP A	OFF	OFF	ON	ON	OFF	OFF	ON	ON
	LINE/RADIO SW	LINE	RADIO	LINE	RADIO	LINE	RADIO	LINE	RADIO
	TAPE/TAPE SW	TAPE	TAPE	TAPE	TAPE	TAPE	TAPE	TAPE	TAPE
	MIC AMP	MUTE	MUTE	ON	MUTE	ON	ON	ON	ON
	BUFFER AMP B	ON	ON	ON	ON	ON	ON	ON	ON
	REC AMP	OFF	OFF	ON	ON	OFF	OFF	ON	ON
	ALC CIRCUIT	ON	ON	ON	ON	ON	ON	ON	ON
	ALC DISCHARGE	ON	ON	OFF	OFF	ON	ON	OFF	OFF
	MONITOR AMP	ON	ON	MUTE	MUTE	ON	ON	ON	ON

OPERATION MODE BY EXTERNAL SWITCH (2 / 2)

SW POSITION	MIC MODE	G : EXT MIC O : MIC OFF H : INT MIC	OPEN MIC MODE							
	REC/PLAY	SW ₃ (21) O : PLAY H : REC	OPEN PLAY BACK MODE				VCC RECORDING MODE			
	SOURCE SELECT	SW ₂ (15) O : $\overline{\text{TAPE}}$ H : TAPE	VCC		OPEN		VCC		OPEN	
SW ₁ (17) O : LINE H : RADIO		VCC	OPEN	VCC	OPEN	VCC	OPEN	VCC	OPEN	
OPERATION MODE	INPUT/SOURCE	TAPE	LINE	RADIO	MIC	LINE	RADIO			
	MONITOR OUT	○	○	○		○	○			
	REC OUT				○	○	○			
INTERNAL OPERATION	NAB AMP	ON	ON	OFF	OFF					
	BUFFER AMP A	OFF	OFF	ON	ON					
	LINE/RADIO SW	LINE	RADIO	LINE	RADIO	LINE	RADIO	LINE	RADIO	
	TAPE/ $\overline{\text{TAPE}}$ SW	TAPE	$\overline{\text{TAPE}}$	TAPE	$\overline{\text{TAPE}}$					
	MIC AMP	MUTE	MUTE	MUTE	MUTE					
	BUFFER AMP B	ON	ON	ON	ON					
	REC AMP	OFF	OFF	ON	ON					
	ALC CIRCUIT	ON	ON	ON	ON					
	ALC DISCHARGE	ON	ON	OFF	OFF					
	MONITOR AMP	ON	ON	ON	ON					

LEVEL DIAGRAM

(1) TAPE IN ⇒ MONITOR OUT (52dB at 315Hz)

TAPE IN	⇒	NAB AMP	⇒	BUF. AMP	⇒	MONI. AMP	⇒	MONI. OUT
G_V	:	45dB (315Hz)		0dB		7dB		
LEVEL	:	0.154mV _{rms} (-74dBm)		0.027V _{rms} (-29dBm)		0.027V _{rms} (-29dBm)		0.062V _{rms} (-22dBm)

(2) RADIO IN ⇒ MONITOR OUT (-2dB)

RADIO IN	⇒	ATT.	⇒	BUF. AMP	⇒	MONI. AMP	⇒	MONI. OUT
G_V	:	-9dB		0dB		7dB		
LEVEL	:	0.078V _{rms} (-20dBm)		0.027V _{rms} (-29dBm)		0.027V _{rms} (-29dBm)		0.062V _{rms} (-22dBm)

(3) RADIO IN ⇒ REC OUT (17dB)

RADIO IN	⇒	ATT.	⇒	ALC	⇒	REC AMP	⇒	REC OUT
G_V	:	-9dB				26dB		
LEVEL	:	0.069V _{rms} (-21dBm)		0.025V _{rms} (-30dBm)		0.025V _{rms} (-30dBm)		0.489V _{rms} (-4dBm)

(4) LINE IN ⇒ MONITOR OUT (7dB)

LINE IN	⇒	BUF. AMP	⇒	MONI. AMP	⇒	MONI. OUT
G_V	:	0dB		7dB		
LEVEL	:	0.027V _{rms} (-29dBm)		0.027V _{rms} (-29dBm)		0.062V _{rms} (-22dBm)

(5) LINE IN ⇒ REC OUT (26dB)

LINE IN	⇒	BUF. AMP	⇒	ALC	⇒	REC AMP	⇒	REC OUT
G_V	:	0dB				26dB		
LEVEL	:	0.025V _{rms} (-30dBm)		0.025V _{rms} (-30dBm)		0.025V _{rms} (-30dBm)		0.489V _{rms} (-4dBm)

(6) MIC IN ⇒ MONITOR OUT (26.5dB)

MIC IN	⇒	MIC AMP	⇒	BUF. AMP	⇒	MONI. AMP	⇒	MONI. OUT
G_V	:	19.5dB		0dB		7dB		
LEVEL	:	2.913mV _{rms} (-48.5dBm)		0.027V _{rms} (-29dBm)		0.027V _{rms} (-29dBm)		0.062V _{rms} (-22dBm)

(7) MIC IN ⇒ REC OUT (45.5dB)

MIC IN	⇒	MIC AMP	⇒	BUF. AMP	⇒	ALC	⇒	REC AMP	⇒	REC OUT
G_V	:	19.5dB		0dB				26dB		
LEVEL	:	2.596mV _{rms} (-49.5dBm)		0.025V _{rms} (-30dBm)		0.025V _{rms} (-30dBm)		0.025V _{rms} (-30dBm)		0.489V _{rms} (-4dBm)

MAXIMUM RATING (Ta = 25°C)

CHARACTERISTIC	SYMBOL	RATING	UNIT
Supply Voltage	V _{CC}	9	V
Power Dissipation	P _D (Note)	1200	mW
Operating Temperature	T _{opr}	-25~75	°C
Storage Temperature	T _{stg}	-55~155	°C

(Note) : Derated above Ta = 25°C in the proportion of 9.6mW/°C.

ELECTRICAL CHARACTERISTICS

(Unless otherwise specified, V_{CC} = 5V, f = 1kHz, Ta = 25°C, BW = 400Hz~30kHz)

CHARACTERISTIC		SYMBOL	TEST CIRCUIT	TEST CONDITION	MIN.	TYP.	MAX.	UNIT	
Quiescent Current		I _{CCQ1}	—	REC MODE	6.0	10.0	16.0	mA	
		I _{CCQ2}	—	PLAY MODE	4.0	7.5	13.0		
Reference Voltage		V _{REF}	—		—	2.1	—	V	
Control Voltage Range	TAPE / TAPE SW (SW ₁ : Pin 15)	V _{TH1A}	—	TAPE MODE (OPEN)	0	—	0.2	V	
		V _{TH1B}	—	TAPE MODE	1.3	—	V _{CC}		
	RADIO / LINE SW (SW ₂ : Pin 17)	V _{TH2A}	—	RADIO MODE (OPEN)	0	—	0.2		
		V _{TH2B}	—	LINE MODE	1.3	—	V _{CC}		
	REC / PLAY SW (SW ₃ : Pin 21)	V _{TH3A}	—	PLAY MODE (OPEN)	0	—	0.2		
		V _{TH3B}	—	REC MODE	1.3	—	V _{CC}		
	MIC SW (SW ₄ : Pin 23)	V _{TH4A}	—	EXT MIC MODE	0	—	0.2		
		V _{TH4B}	—	MIC OFF MODE (OPEN)	—	OPEN	—		
V _{TH4C}		—	INT MIC MODE	1.6	—	V _{ref}			
RADIO Mode	Playback	Voltage Gain	G _{v1}	—	V _{out} = -10dBV	-4	-2	0	dB
		Maximum Output Voltage	V _{om1}	—	THD = 1%	1.0	1.2	—	V _{rms}
		Output Noise Voltage	V _{no1}	—	MIC OFF MODE, R _g = 620Ω, DIN AUDIO	—	-98	-90	dBV
		Total Harmonic Distortion	THD1	—	V _{out} = -10dBV	—	0.2	—	%
		Cross Talk	C.T.1	—	V _{out} = -10dBV	—	-60	—	dB
		Ripple Rejection Ratio	R.R.1	—	MIC OFF MODE, V _{rip} = -20dBV, f = 100Hz, BW = ~30kHz	—	-52	—	dB

CHARACTERISTIC		SYM-BOL	TEST CIR-CUIT	TEST CONDITION	MIN.	TYP.	MAX.	UNIT	
RADIO Mode	REC	Voltage Gain	G_{v2}	—	$V_{out} = -10\text{dBV}$	15	17	19	dB
		Output Noise Voltage	V_{no2}	—	MIC OFF MODE, $R_g = 620\Omega$, DIN AUDIO	—	-77	-68	dBV
		Total Harmonic Distortion	THD2	—	$V_{in} = -6\text{dBV}$, ALC = ON	—	0.3	—	%
		Cross Talk	C.T.2	—	$V_{out} = -10\text{dBV}$	—	-57	—	dB
		Ripple Rejection Ratio	R.R.2	—	MIC OFF MODE, $V_{rip} = -20\text{dBV}$, $f = 100\text{Hz}$, $BW = \sim 30\text{kHz}$	—	-40	—	dB
		ALC Level	ALC21	—	$V_{in} = -16\text{dBV}$	Dual channel input	-4	-2	0
ALC22	—		$V_{in} = 4\text{dBV}$	-4	-1		2		
LINE Mode	Playback	Voltage Gain	G_{v3}	—	$V_{out} = -10\text{dBV}$	5	7	9	dB
		Maximum Output Voltage	V_{om3}	—	THD = 1%	1.0	1.2	—	V_{rms}
		Output Noise Voltage	V_{no3}	—	MIC OFF MODE, $R_g = 620\Omega$, DIN AUDIO	—	-98	-90	dBV
		Total Harmonic Distortion	THD3	—	$V_{out} = -10\text{dBV}$	—	0.2	—	%
		Cross Talk	C.T.3	—	$V_{out} = -10\text{dBV}$	—	-60	—	dB
		Ripple Rejection Ratio	R.R.3	—	MIC OFF MODE, $V_{rip} = -20\text{dBV}$, $f = 100\text{Hz}$, $BW = \sim 30\text{kHz}$	—	-52	—	dB
	REC	Voltage Gain	G_{v4}	—	$V_{out} = -10\text{dBV}$	24	26	28	dB
		Output Noise Voltage	V_{no4}	—	MIC OFF MODE, $R_g = 620\Omega$, DIN AUDIO	—	-77	-68	dBV
		Total Harmonic Distortion	THD4	—	$V_{in} = -16\text{dBV}$, ALC = ON	—	0.3	—	%
		Cross Talk	C.T.4	—	$V_{out} = -10\text{dBV}$	—	-56	—	dB
		Ripple Rejection Ratio	R.R.4	—	MIC OFF MODE, $V_{rip} = -20\text{dBV}$, $f = 100\text{Hz}$, $BW = \sim 30\text{kHz}$	—	-37	—	dB
		ALC Level	ALC41	—	$V_{in} = -26\text{dBV}$	Dual channel input	-4	-2	0
ALC42	—		$V_{in} = -6\text{dBV}$	-4	-1		2		

CHARACTERISTIC		SYM-BOL	TEST CIR-CUIT	TEST CONDITION	MIN.	TYP.	MAX.	UNIT	
TAPE Mode	Open Loop Voltage Gain	G_{vo5}	—	$V_{out} = -10dBV$	—	97	—	dB	
	Closed Loop Voltage Gain	G_{v5}	—	$V_{out} = -10dBV$	41.5	43.5	45.5	dB	
	Maximum Output Voltage	V_{om5}	—	THD = 1%	1.0	1.2	—	V_{rms}	
	Output Noise Voltage	V_{no5}	—	MIC OFF MODE, $R_g = 620\Omega$, DIN AUDIO	—	-73	-65	dBV	
	Total Harmonic Distortion	THD5	—	$V_{out} = -10dBV$	—	0.2	—	%	
	Cross Talk	C.T.5	—	$V_{out} = -10dBV$	—	-57	—	dB	
	Ripple Rejection Ratio	R.R.5	—	MIC OFF MODE, $V_{rip} = -20dBV$, $f = 100Hz$, $BW = \sim 30kHz$	—	-33	—	dB	
MIC Mode	Playback	Voltage Gain	G_{v6}	—	$V_{out} = -10dBV$	25.5	27.5	29.5	dB
		Maximum Output Voltage	V_{om6}	—	THD = 1%	1.0	1.2	—	V_{rms}
		Output Noise Voltage	V_{no6}	—	EXT. MIC MODE, $R_g = 620\Omega$, DIN AUDIO	—	-87	-79	dBV
		Total Harmonic Distortion	THD6	—	$V_{out} = -10dBV$	—	0.24	—	%
		Ripple Rejection Ratio	R.R.6	—	INT. MIC MODE, $V_{rip} = -20dBV$, $f = 100Hz$, $BW = \sim 30kHz$	—	-52	—	dB
	REC	Voltage Gain	G_{v7}	—	$V_{out} = -10dBV$	44.5	46.5	48.5	dB
		Maximum Output Voltage	V_{om7}	—	THD = 1%, ALC = OFF	1.0	1.2	—	V_{rms}
		Output Noise Voltage	V_{no7}	—	INT. MIC / EXT. MIC MODE, $R_g = 620\Omega$ DIN AUDIO	—	-70	-61	dBV
		Total Harmonic Distortion	THD7	—	$V_{in} = -36dBV$, ALC = ON	—	0.3	—	%
		Ripple Rejection Ratio	R.R.7	—	INT. MIC / EXT. MIC MODE, $V_{rip} = -20dBV$, $f = 100Hz$, $BW = \sim 30kHz$	—	-47	—	dB
		ALC Level	ALC71	—	$V_{in} = -46dBV$	Dual channel input	-4	-2	0
ALC72	—		$V_{in} = -26dBV$	-4	-1		2		

DC VOLTAGE AT EACH TERMINAL ($V_{CC} = 5V$, $V_{in} = 0$, $T_a = 25^\circ C$)

TERMINAL No.	1	2	3	4	5	6	7	8
DC VOLTAGE [V]	1.0 (REC)	2.1	2.1	2.1	2.1	2.1	0 (GND)	2.1
	0.1 (PLAY)							
TERMINAL No.	9	10	11	12	13	14	15	16
DC VOLTAGE [V]	2.1	2.1	2.1	2.1	2.1	2.1	0 (OPEN)	2.1
TERMINAL No.	17	18	19	20	21	22	23	24
DC VOLTAGE [V]	0 (OPEN)	2.1	5.0 (V_{CC})	2.1	0 (OPEN)	2.1	0 (OPEN)	2.1

TEST CIRCUIT

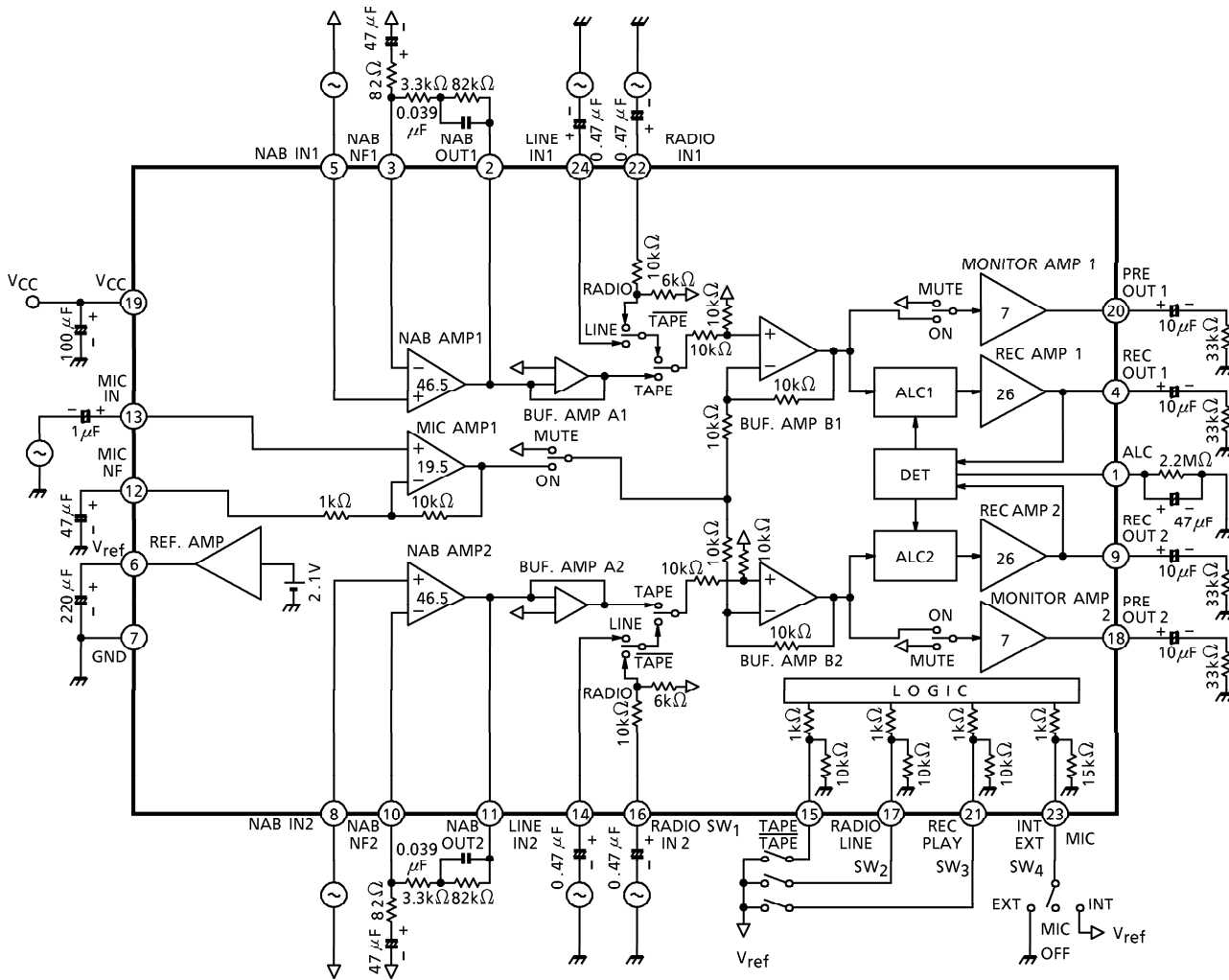

(*) 23pin : For mic off mode, should be open. Don't add any external voltage.

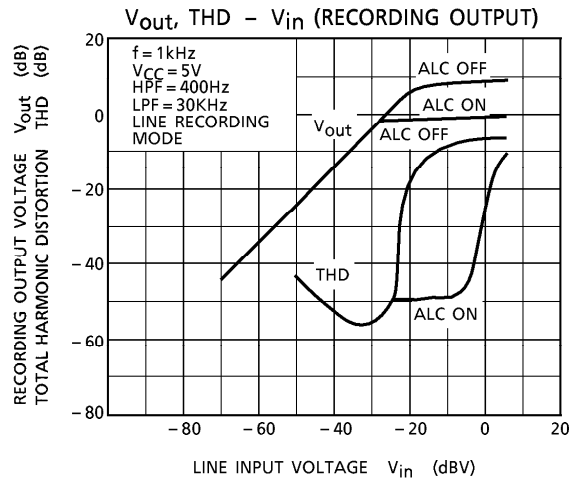
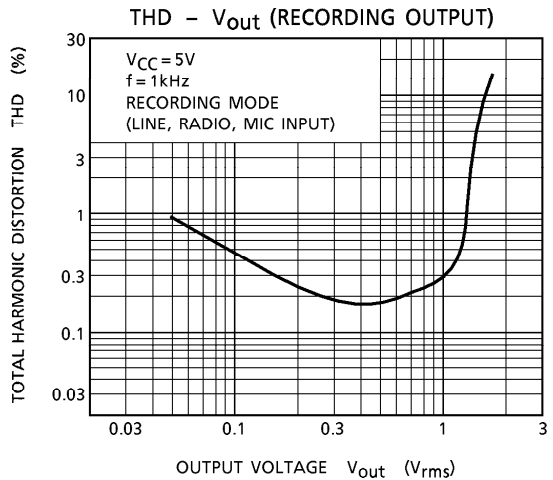
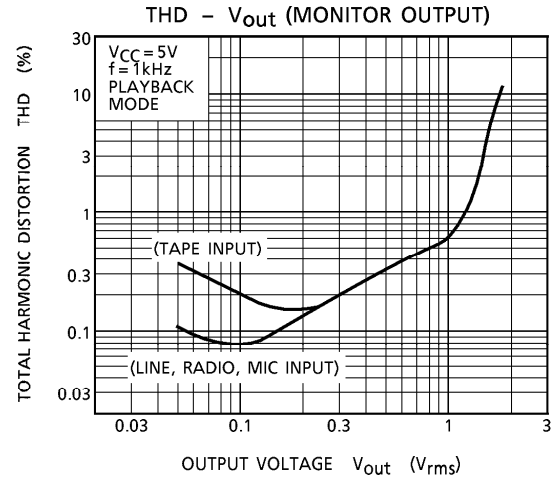
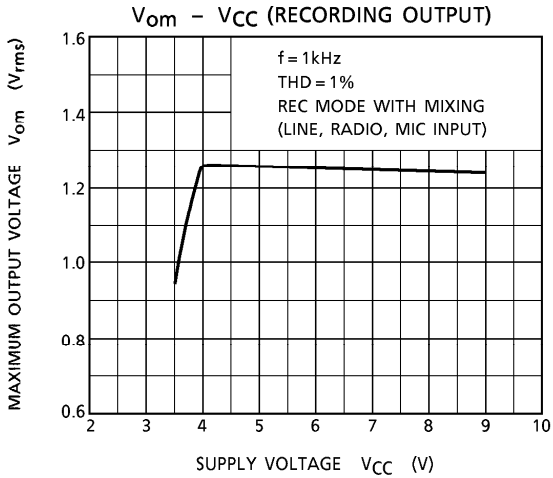
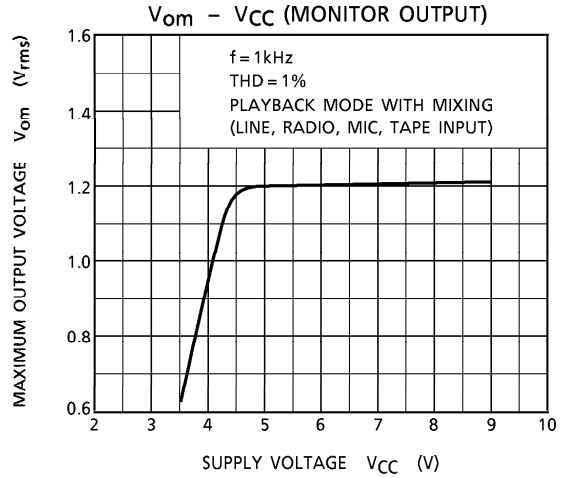
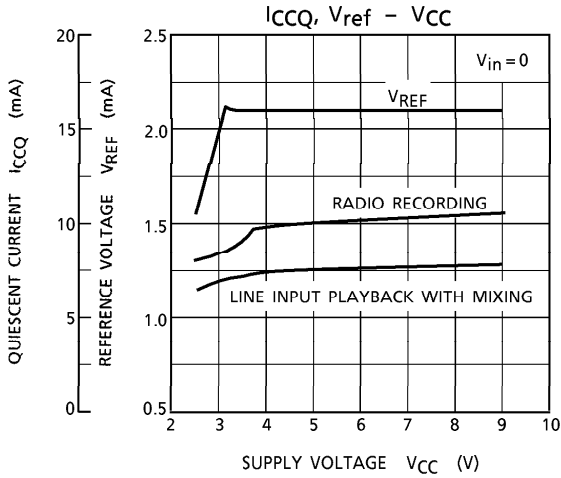

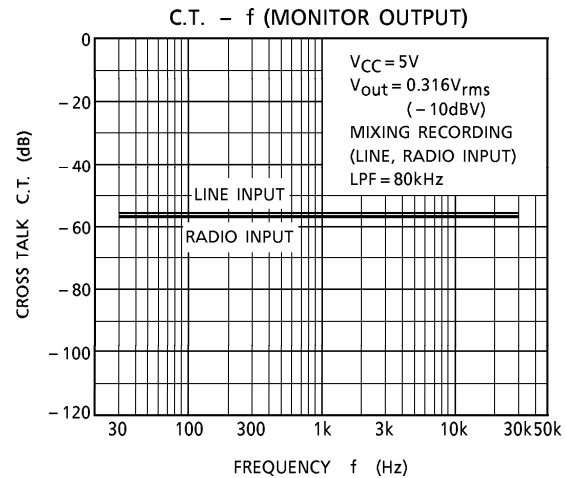
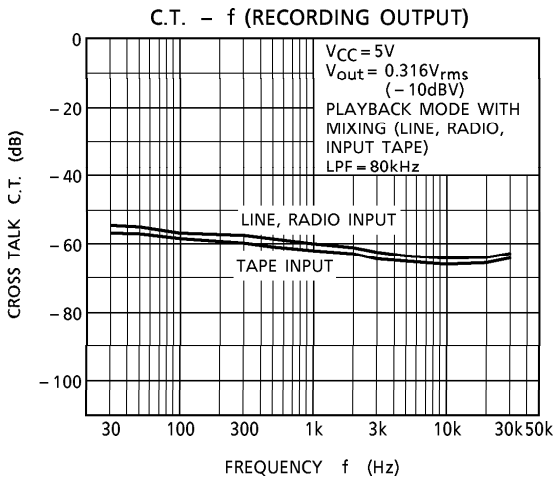
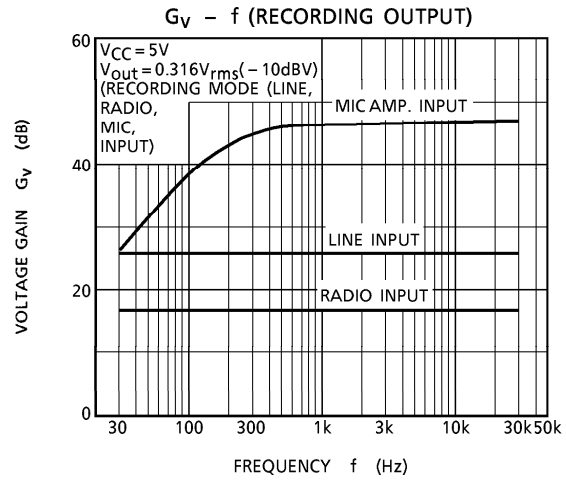
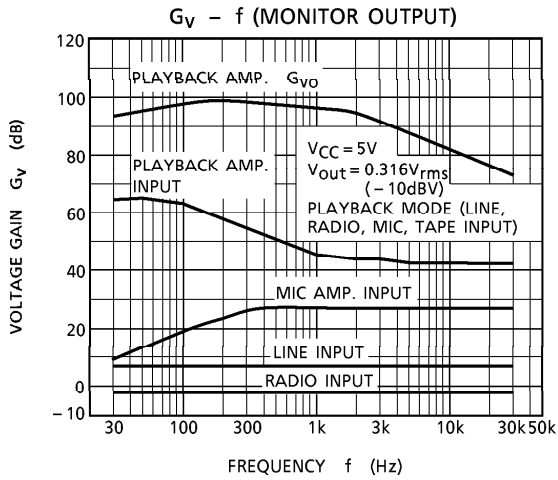
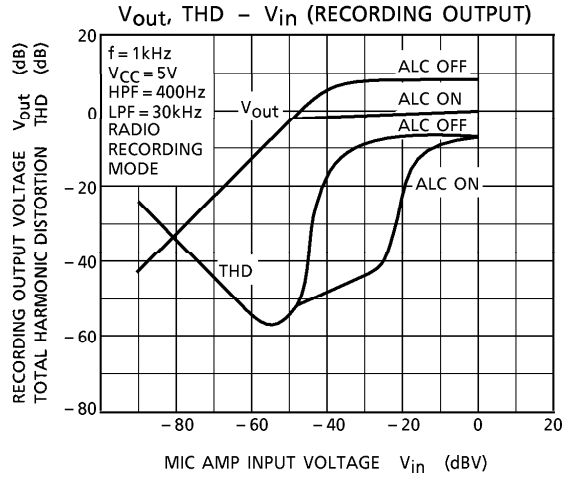
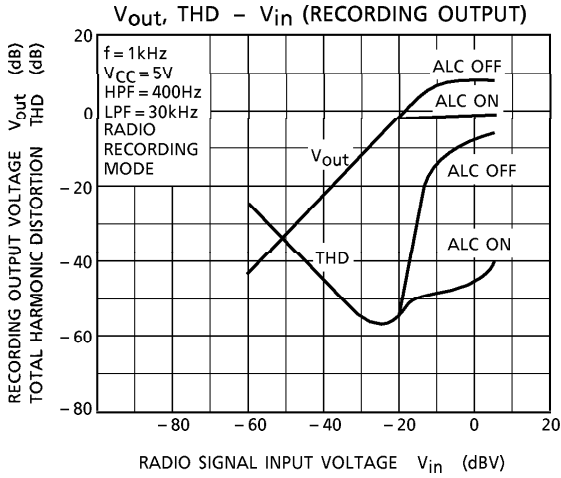

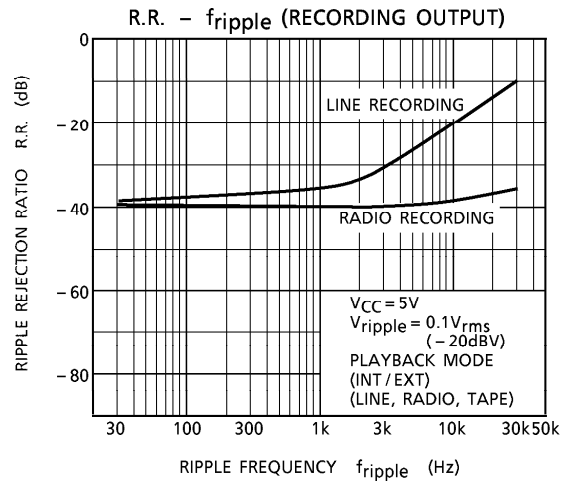
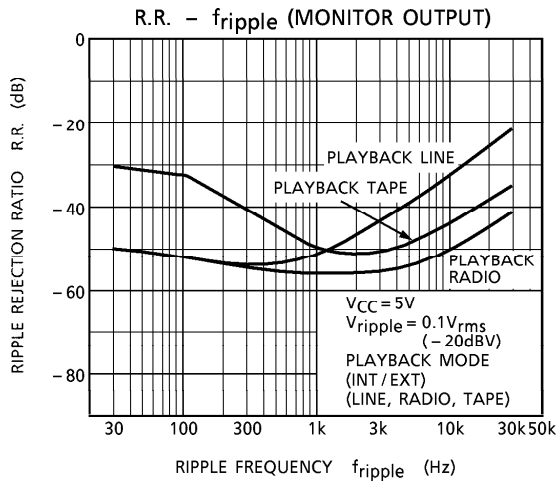

OUTLINE DRAWING
SDIP24-P-300-1.78

Unit : mm

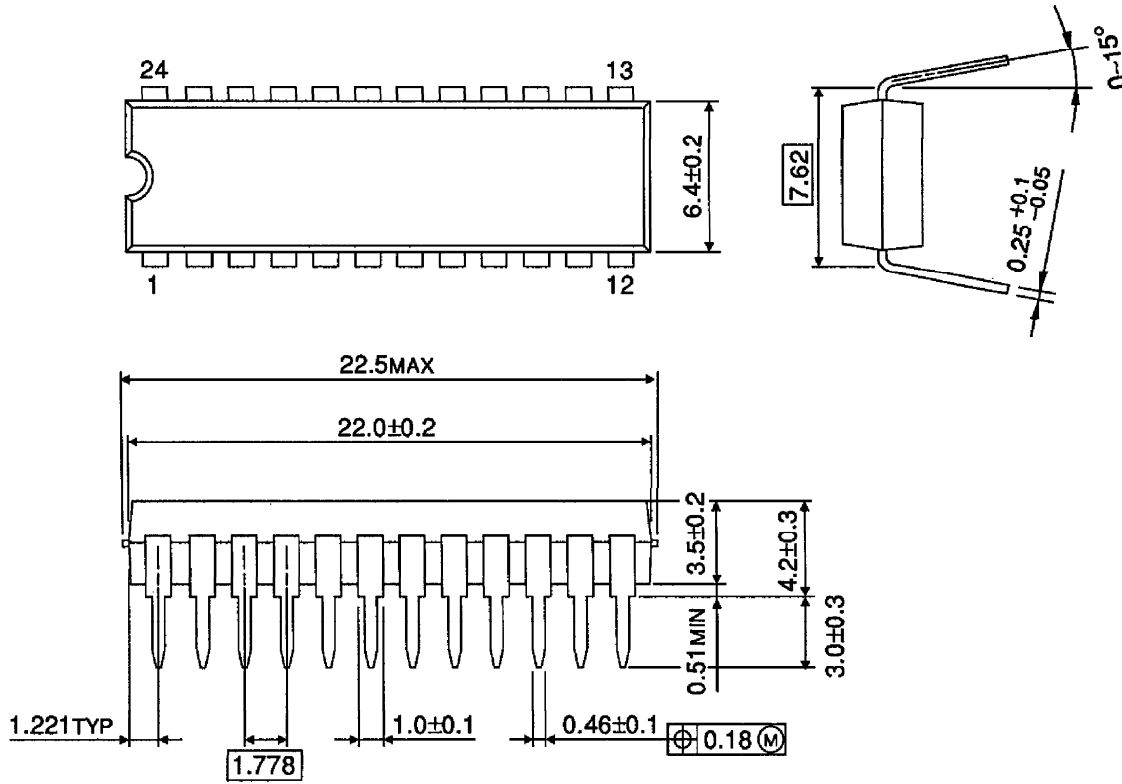

Weight : 1.2g (Typ.)