

TOSHIBA

TA7331P/F

TOSHIBA BIPOLAR LINEAR INTEGRATED CIRCUIT SILICON MONOLITHIC

TA7331P, TA7331F

LOW QUIESCENT CURRENT AUDIO POWER AMPLIFIER FOR MINI / MICRO CASSETTE TAPE RECORDER

The TA7331P and TA7331F are an audio power amplifier designed for use in low voltage consumer applications. Especially it is suitable for mini / micro cassette tape recorder and pocket radio applications. As the quiescent current is only 3mA at 3V, it is best for battery operation.

FEATURES

- Operating supply voltage range
: $V_{CC(opr)} = 2 \sim 5V \cdots TA7331P$ ($T_a = 25^\circ C$)
 $V_{CC(opr)} = 2 \sim 4V \cdots TA7331F$ ($T_a = 25^\circ C$)
- Low quiescent current : $I_{CCQ} = 3mA$ (Typ.)
($V_{CC} = 3V, T_a = 25^\circ C$)
- OTL audio power amplifier
- TA7331F (SO) is standard model of flat package

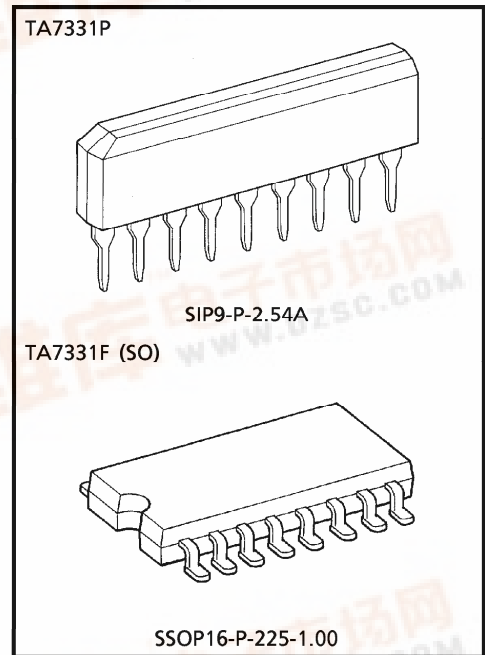

Weight
SIP9-P-2.54A : 0.92g (Typ.)
SSOP16-P-225-1.00 : 0.14g (Typ.)

OUTPUT POWER TABLE ($f = 1kHz, THD = 10\%, T_a = 25^\circ C$)

CONDITION		PACKAGE	TA7331P	TA7331F
$V_{CC} = 3V$		$R_L = 8\Omega$	120mW	120mW
		$R_L = 4\Omega$	200mW	200mW
		$R_L = 8\Omega$ BTL	400mW	400mW
$V_{CC} = 4.5V$		$R_L = 8\Omega$	300mW	Cannot use
		$R_L = 4\Omega$	500mW	

961001EBA2

- TOSHIBA is continually working to improve the quality and the reliability of its products. Nevertheless, semiconductor devices in general can malfunction or fail due to their inherent electrical sensitivity and vulnerability to physical stress. It is the responsibility of the buyer, when utilizing TOSHIBA products, to observe standards of safety, and to avoid situations in which a malfunction or failure of a TOSHIBA product could cause loss of human life, bodily injury or damage to property. In developing your designs, please ensure that TOSHIBA products are used within specified operating ranges as set forth in the most recent products specifications. Also, please keep in mind the precautions and conditions set forth in the TOSHIBA Semiconductor Reliability Handbook.
- The products described in this document are subject to foreign exchange and foreign trade control laws.
- The information contained herein is presented only as a guide for the applications of our products. No responsibility is assumed by TOSHIBA CORPORATION for any infringements of intellectual property or other rights of the third parties which may result from its use. No license is granted by implication or otherwise under any intellectual property or other rights of TOSHIBA CORPORATION or others.
- The information contained herein is subject to change without notice.

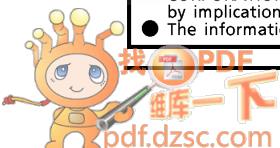

TEST CIRCUIT / BLOCK DIAGRAM

TA7331P

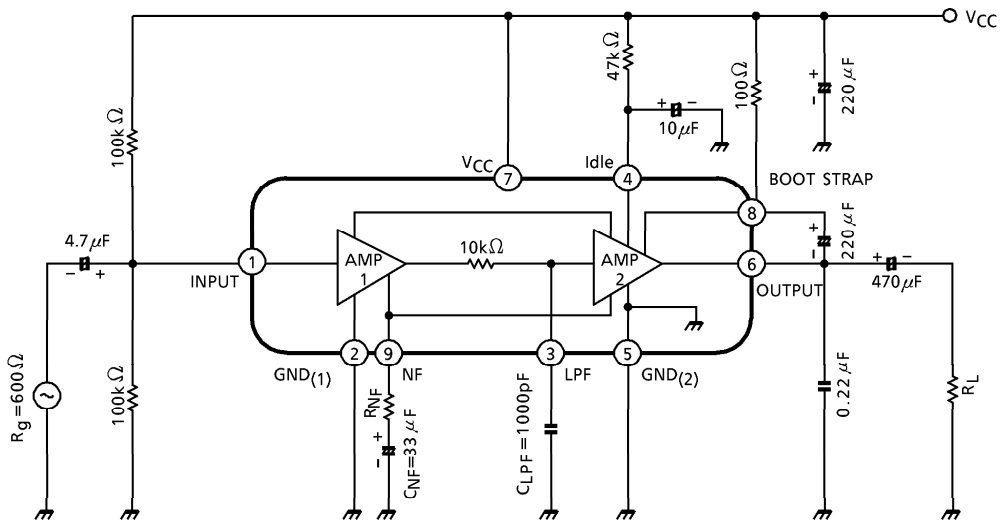

TA7331F

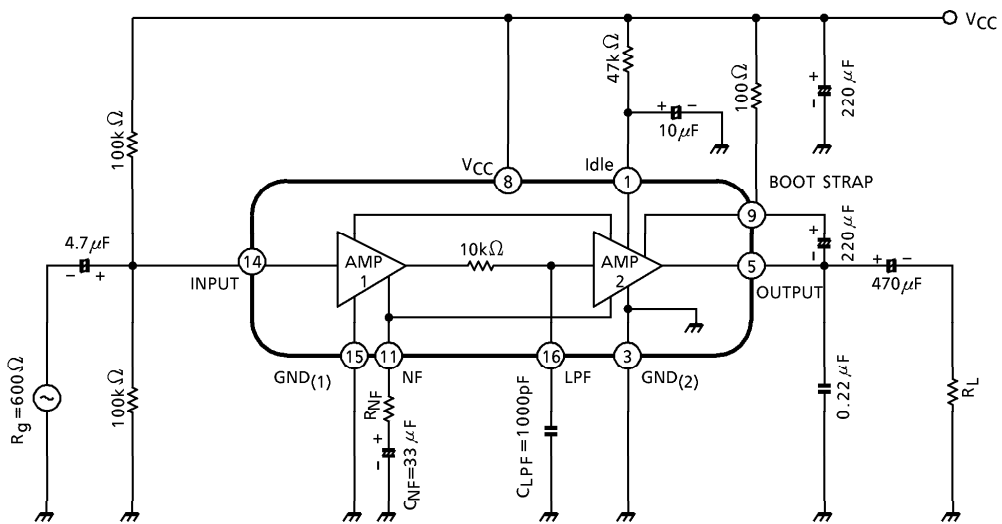

MAXIMUM RATINGS (Ta = 25°C)

CHARACTERISTIC		SYMBOL	RATING	UNIT
Supply Voltage		V _{CC}	8	V
Operating Supply Voltage	TA7331P	V _{CC}	5	V
	TA7331F		4	
Power Dissipation	TA7331P	P _D (Note)	700	mW
	TA7331F		350	
Operating Temperature		T _{opr}	-10~60	°C
Storage Temperature		T _{stg}	-55~150	°C

(Note) Derated above 25°C in the proportion of 5.6mW/°C for TA7331P and 2.8mW/°C for the TA7331F.

ELECTRICAL CHARACTERISTICS

TA7331P

Unless otherwise specified, V_{CC} = 3V, f = 1kHz, R_L = 4Ω, Ta = 25°C

CHARACTERISTIC	SYMBOL	TEST CIR-CUIT	TEST CONDITION	MIN.	TYP.	MAX.	UNIT
Quiescent Current	I _{CCQ} (1)	—		—	3	5	mA
	I _{CCQ} (2)	—	V _{CC} = 4.5V	—	5	6.5	
Voltage Gain	G _V (1)	—	R _{NF} = 0Ω, C _{NF} = 33μF	47	50	53	dB
	G _V (2)	—	R _{NF} = 82Ω, C _{NF} = 33μF	—	40	—	
Output Power	P _O (1)	—	THD = 10%	170	200	—	mW
	P _O (2)	—	R _L = 8Ω, THD = 10%, V _{CC} = 4.5V	—	300	—	
Total Harmonic Distortion	THD (1)	—	P _O = 100mW, R _{NF} = 0Ω	—	1.0	5	%
	THD (2)	—	P _O = 50mW, R _{NF} = 0Ω, R _L = 8Ω	—	0.8	—	
Output Noise Voltage	V _{no}	—	R _g = 1kΩ, BPF ≐ 50Hz~20kHz	—	0.2	0.4	mV _{rms}

TA7331F

Unless otherwise specified, V_{CC} = 3V, f = 1kHz, R_L = 4Ω, Ta = 25°C

CHARACTERISTIC	SYMBOL	TEST CIR-CUIT	TEST CONDITION	MIN.	TYP.	MAX.	UNIT
Quiescent Current	I _{CCQ} (1)	—		—	3	5	mA
Voltage Gain	G _V (1)	—	R _{NF} = 0Ω, C _{NF} = 33μF	47	50	53	dB
	G _V (2)	—	R _{NF} = 82Ω, C _{NF} = 33μF	—	40	—	
Output Power	P _O (1)	—	THD = 10%	170	200	—	mW
Total Harmonic Distortion	THD (1)	—	P _O = 100mW, R _{NF} = 0Ω	—	1.0	5	%
	THD (2)	—	P _O = 50mW, R _{NF} = 0Ω, R _L = 8Ω	—	0.8	—	
Output Noise Voltage	V _{no}	—	R _g = 1kΩ, BPF ≐ 50Hz~20kHz	—	0.2	0.4	mV _{rms}

CHARACTERISTIC CURVES

(Note) Data above $V_{CC} = 4V$ is only TA7331P.

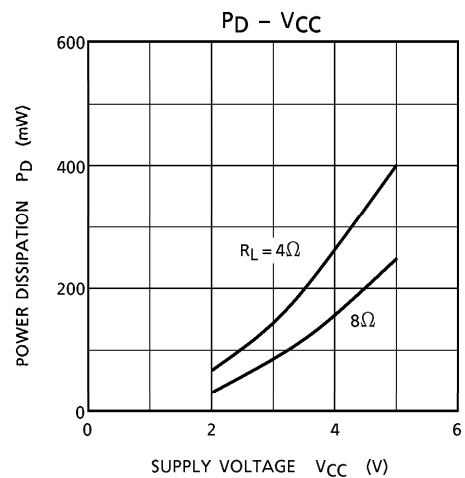
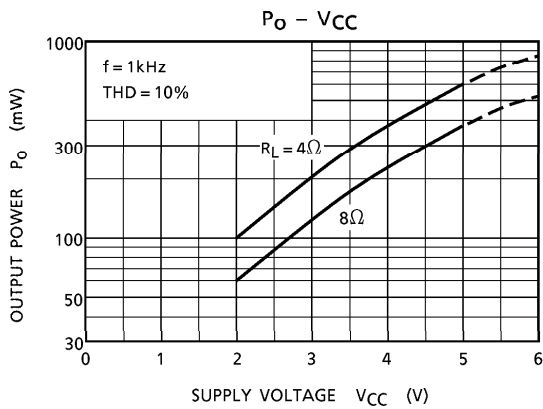
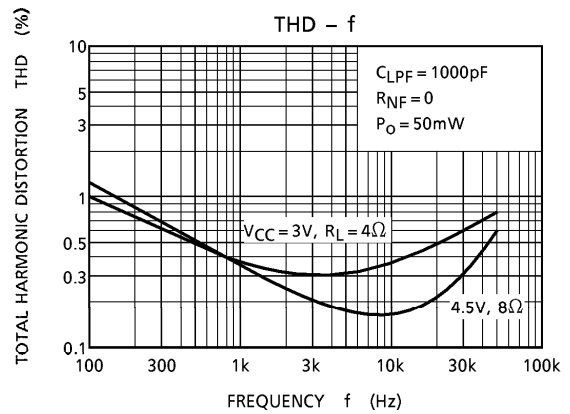
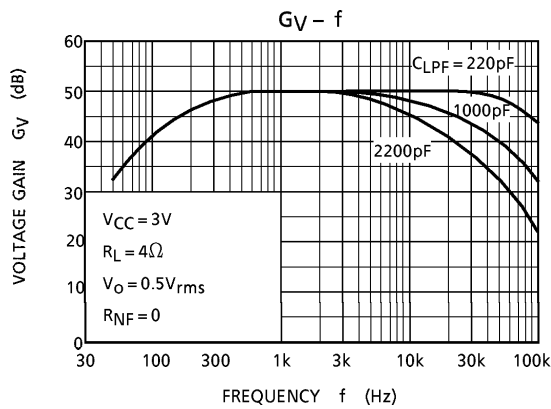
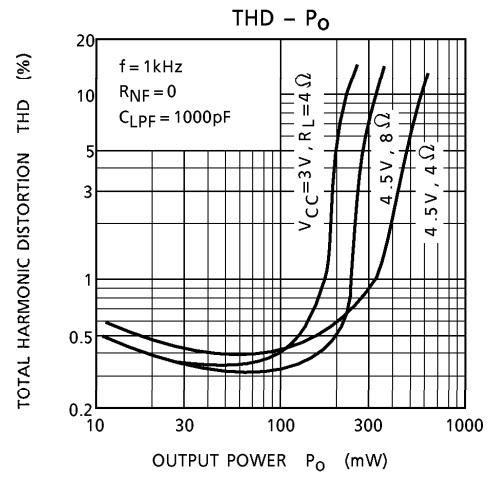
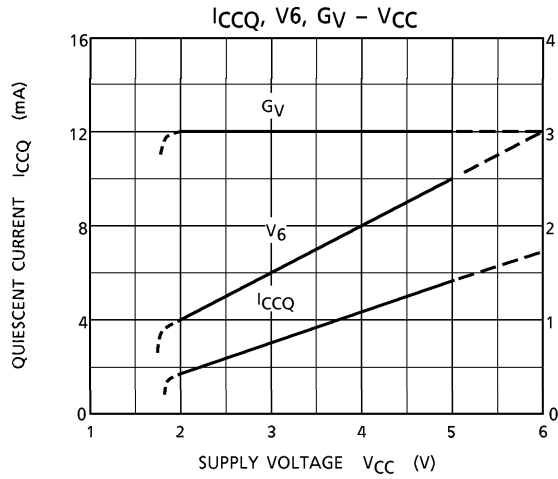

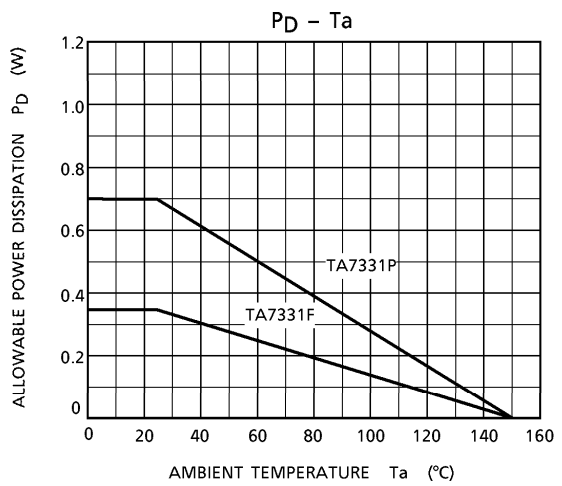
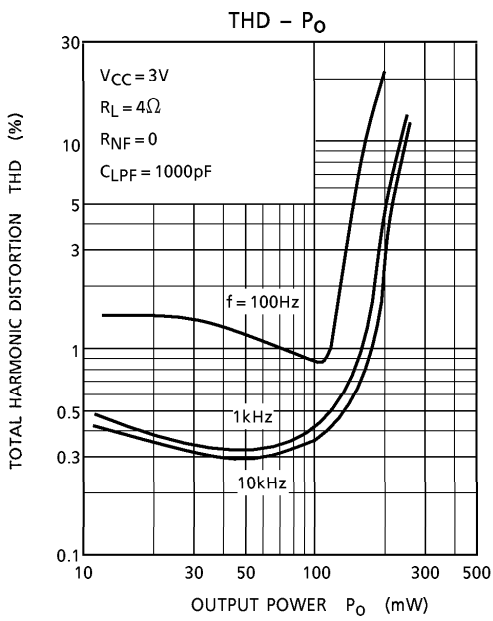
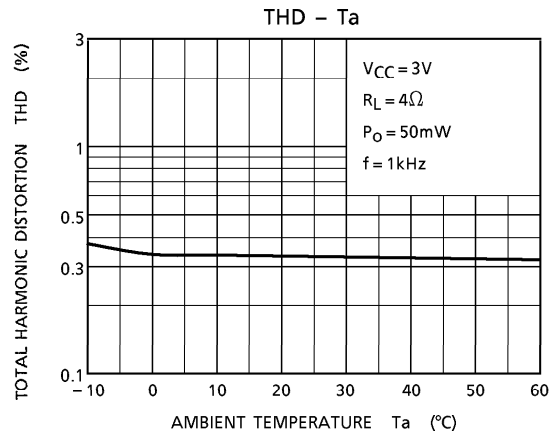
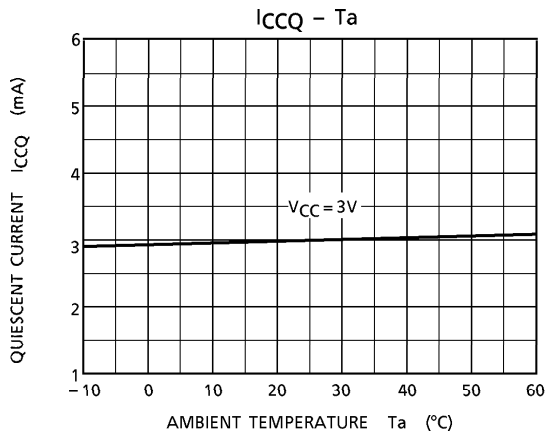

TA7331P

APPLICATION 1 (BTL CONNECTION)

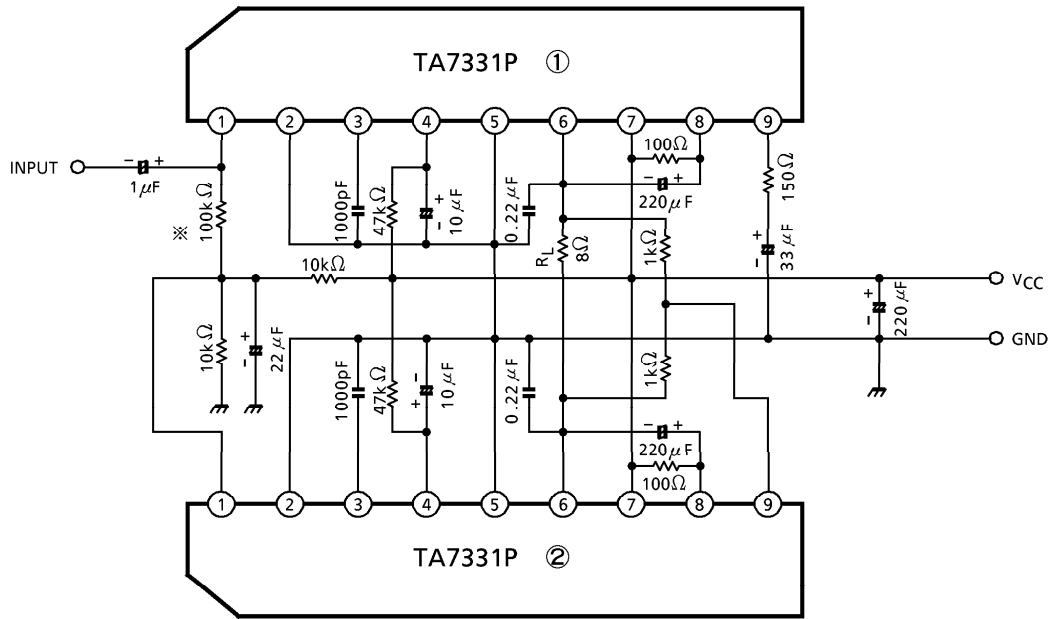

※ It is necessary to adjust to I_{CCQ} .

APPLICATION 2 (FEW EXTERNAL PARTS)

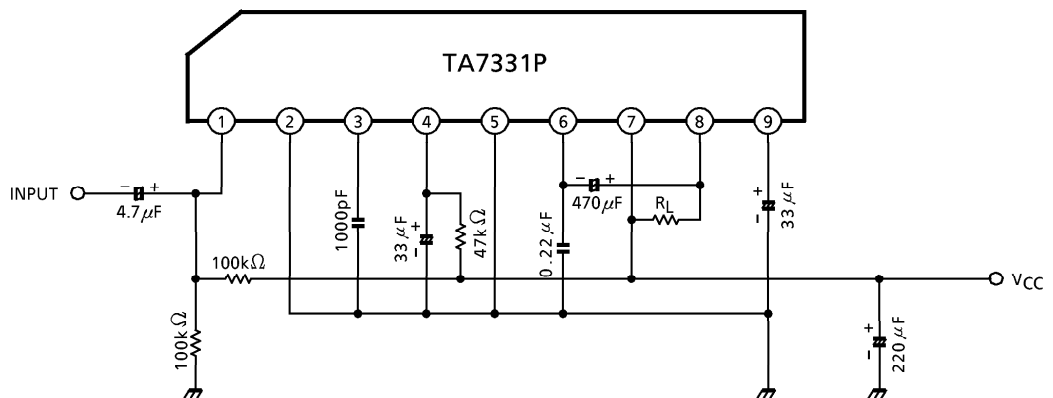

APPLICATION 3

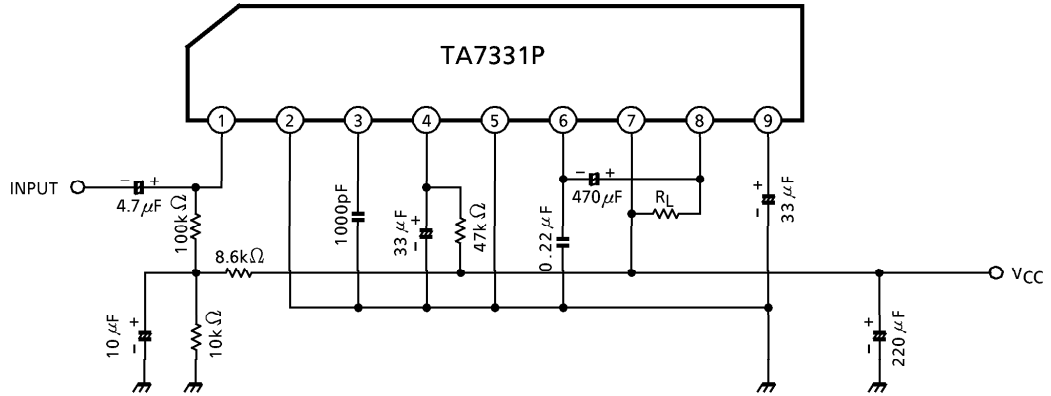

TA7331F
APPLICATION 1 (BTL CONNECTION)

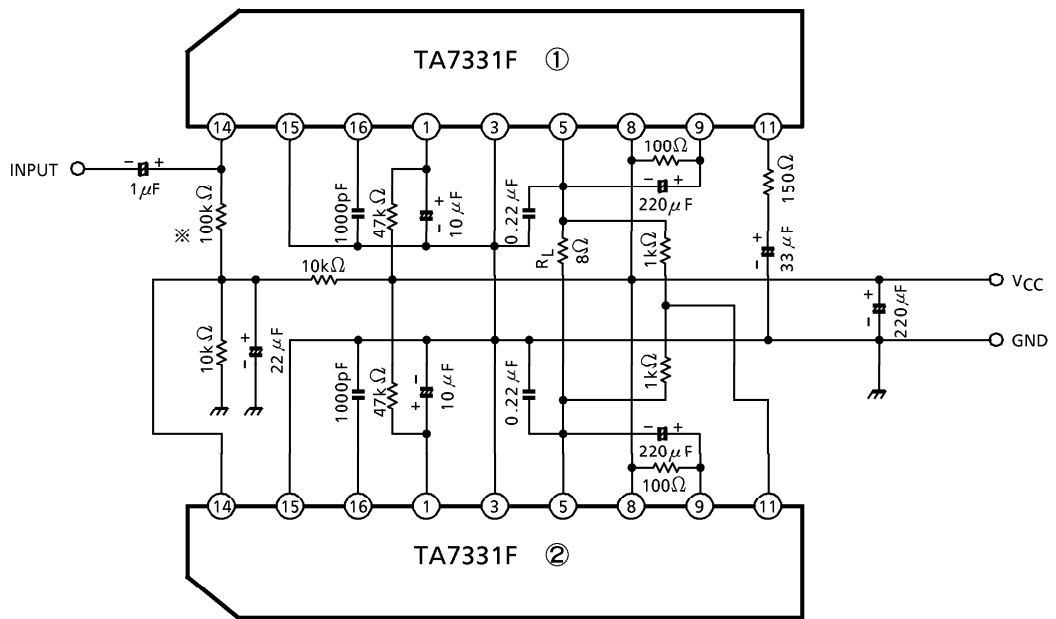

※ It is necessary to adjust to I_{CCQ}.

APPLICATION 2 (FEW EXTERNAL PARTS)

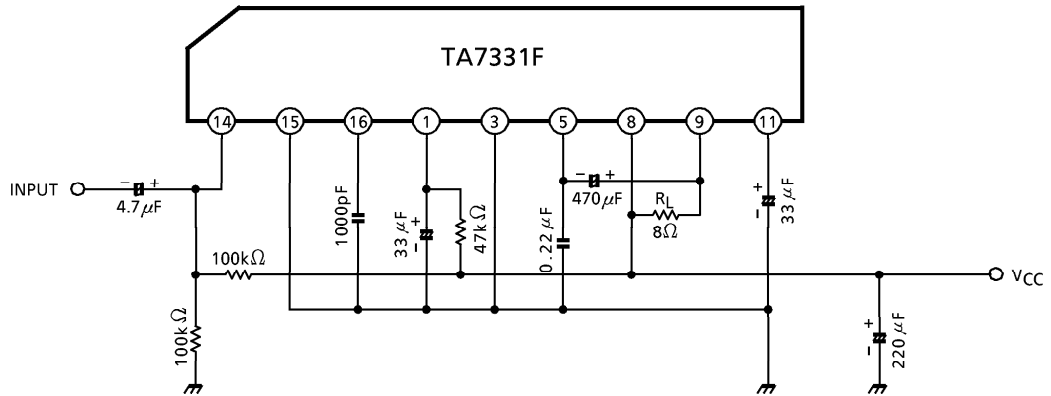

APPLICATION 3

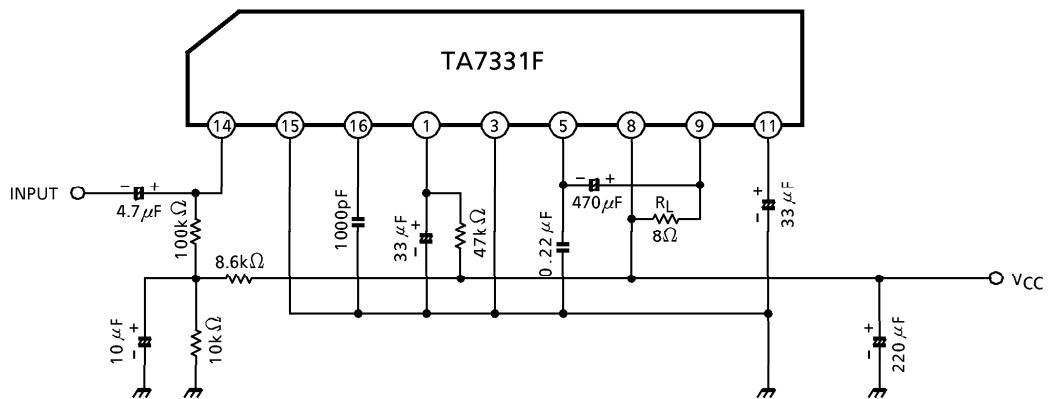

OUTLINE DRAWING
SIP9-P-2.54A

Unit : mm

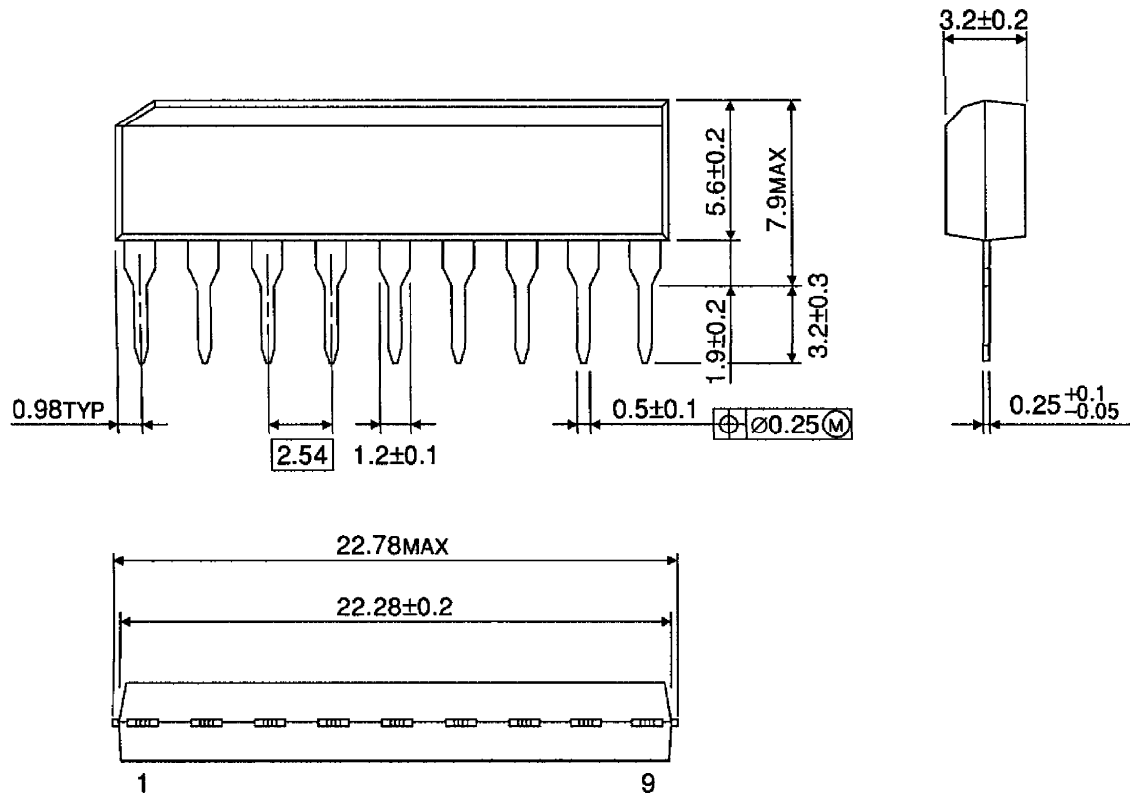

Weight : 0.92g (Typ.)

OUTLINE DRAWING
SSOP16-P-225-1.00

Unit : mm

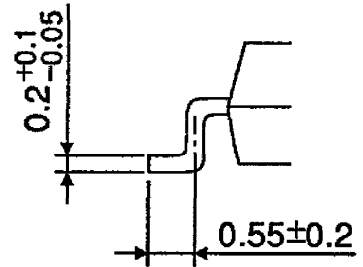
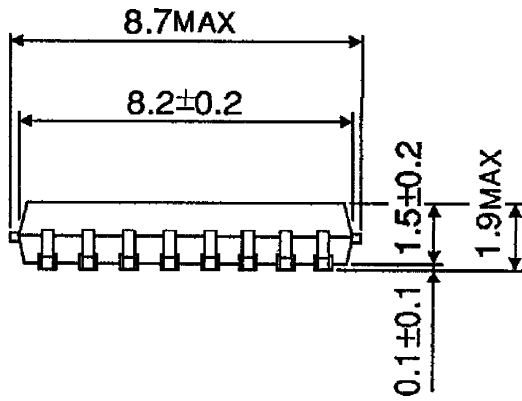
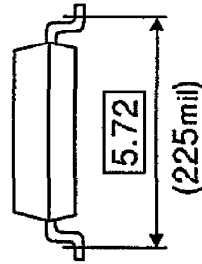
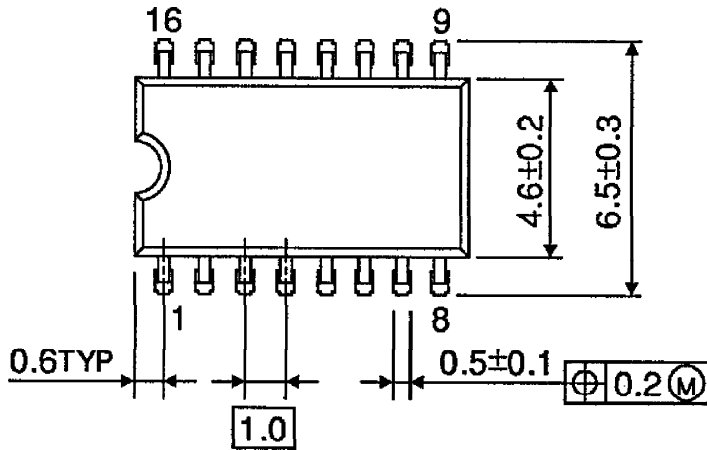

Weight : 0.14g (Typ.)