

TOSHIBA

TA7354P

TOSHIBA BIPOLAR LINEAR INTEGRATED CIRCUIT SILICON MONOLITHIC

TA7354P

BRIDGE DRIVER

The TA7354P is a Bridge Driver for brushed DC Motor Rotation control.

Forward Rotation, Reverse Rotation, Stop and Braking operations are available.

It's designed for Loading and Reel Motor driver for VTR and Tape Deck, and any other consumer and industrial applications.

TA7354P have Operation Supply Voltage terminal and Motor Driving Supply Voltage terminal independently, therefore Servo control operation is applicable.

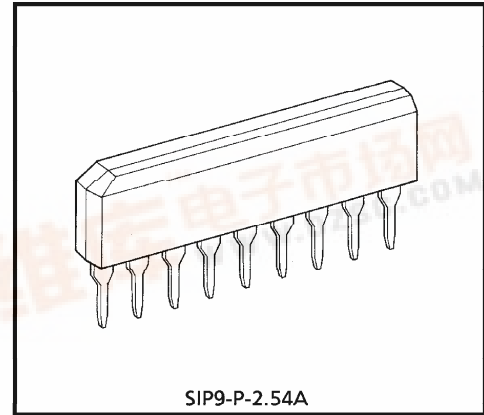

SIP9-P-2.54A

Weight : 0.92g (Typ.)

FEATURES

- Output Current Up to 0.2A (AVE.), and 0.6A (PEAK).
- 4 Function Modes (CW, CCW, STOP and Brake) are Controlled by 2 Logic Signals Fed Into 2 Input Terminals.
- Operating Voltage Range : $V_{CC} = 6\sim 15V$

BLOCK DIAGRAM

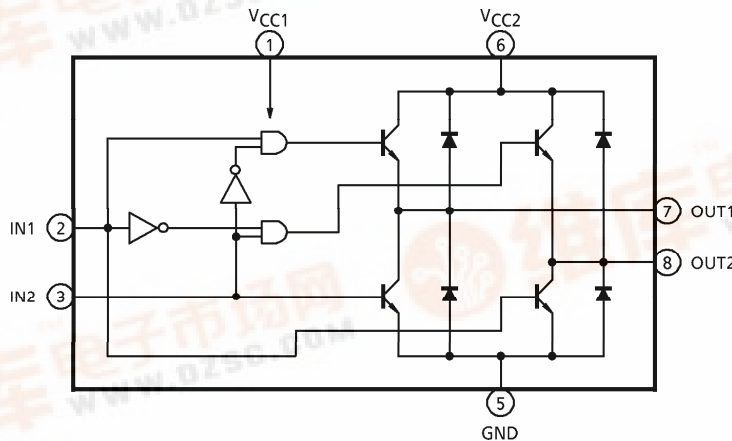

961001EBA2

- TOSHIBA is continually working to improve the quality and the reliability of its products. Nevertheless, semiconductor devices in general can malfunction or fail due to their inherent electrical sensitivity and vulnerability to physical stress. It is the responsibility of the buyer, when utilizing TOSHIBA products, to observe standards of safety, and to avoid situations in which a malfunction or failure of a TOSHIBA product could cause loss of human life, bodily injury or damage to property. In developing your designs, please ensure that TOSHIBA products are used within specified operating ranges as set forth in the most recent products specifications. Also, please keep in mind the precautions and conditions set forth in the TOSHIBA Semiconductor Reliability Handbook.
- The products described in this document are subject to foreign exchange and foreign trade control laws.
- The information contained herein is presented only as a guide for the applications of our products. No responsibility is assumed by TOSHIBA CORPORATION for any infringements of intellectual property or other rights of the third parties which may result from its use. No license is granted by implication or otherwise under any intellectual property or other rights of TOSHIBA CORPORATION or others.
- The information contained herein is subject to change without notice.



PIN FUNCTION

PIN No.	SYMBOL	FUNCTIONAL DESCRIPTION
1	V _{CC1}	Supply voltage terminal for control part
2	IN1	input terminal-1
3	IN2	input terminal-2
4	—	No. connection
5	GND	GND terminal
6	V _{CC2}	Supply voltage terminal for output part
7	OUT1	Output terminal-1
8	OUT2	Output terminal-2
9	—	No. connection

FUNCTION

IN1	IN2	OUT1	OUT2	MODE
1	1	L	L	Brake
0	1	L	H	CW / CCW
1	0	H	L	CCW / CW
0	0	High Impedance		Stop

MAXIMUM RATINGS (Ta = 25°C)

CHARACTERISTIC		SYMBOL	RATING	UNIT
Supply Voltage	PEAK	V _{CC} (MAX.)	18	V
	OPERATE	V _{CC} (ope.)	15	
Output Current	PEAK	I _O (PEAK)	0.6	A
	AVE.	I _O (AVE.)	0.2	
Power Dissipation		P _D (*)	0.75	W
Operating Temperature		T _{opr}	- 30~75	°C
Storage Temperature		T _{stg}	- 55~150	°C

(*) No Heat Sink

ELECTRICAL CHARACTERISTICS (Unless otherwise specified, Ta = 25°C)

CHARACTERISTIC		SYMBOL	TEST CIRCUIT	TEST CONDITION	MIN.	TYP.	MAX.	UNIT
Supply Current		I _{CC1}	—	V _{CC1} = V _{CC2} = 15V I _O = 0.2A Drive mode	—	22	33	mA
		I _{CC2}		V _{CC1} = V _{CC2} = 15V Brake mode	—	30	38	
		I _{CC3}		V _{CC1} = V _{CC2} = 15V Stop mode	—	0.2	1	
Saturation Voltage	Upper	V _{S1 U}	—	V _{CC1} = V _{CC2} = 15V, I _O = 0.1A	—	0.8	1.05	V
	Lower	V _{S1 L}			—	0.15	0.25	
	Upper	V _{S2 U}		V _{CC1} = V _{CC2} = 15V, I _O = 0.2A	—	0.9	1.2	
	Lower	V _{S2 L}			—	0.3	0.5	
Leakage Current	Upper	I _{L U}	—	V = 15V	—	—	20	μA
	Lower	I _{L L}			—	—	20	
Input Voltage 1, 2		V _{IN (H)}	—	T _j = 25°C Pin① and pin②	2.0	—	—	V
		V _{IN (L)}			—	—	0.8	
Input Current 1, 2		I _{IN1, 2}	—	V _{IN} = 4.5V	—	—	350	μA
Diode Forward Voltage		V _{F U}	—	I _F = 0.2A	—	1.2	1.6	V
		V _{F L}			—	1.0	1.3	

APPLICATION CIRCUIT

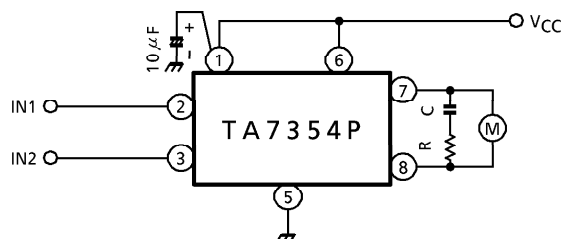

Fig.1

(Note) Fig.1 shows the basic application circuit.
Optimum values of the C, R depend on the inherent constant of a motor and parasitic C, R values around the circuit.

APPLICATION NOTE

(1) Input circuit

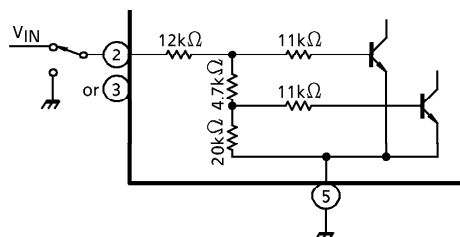

Fig.2

Input circuit is shown in Fig.2. It's a "High Active" type.
If a voltage above specified $V_{IN(H)}$ value fed into input terminal that means "Logic 1", and the voltage less than $V_{IN(L)}$ or connect to GND means "Logic 0".
And the circuit have a hysteresis for stable operation. (See Fig.1)

- (2) If the braking operation is so loose, connect a additional diode between each output to GND. (See Fig.3)
- (3) If the back electromotive pulse generated in output coil is so strong. Internally connected back electromotive suppression diode may be damaged by this pulse. In such a case connect a additional diode between each output to V_{CC} . (See Fig.4)

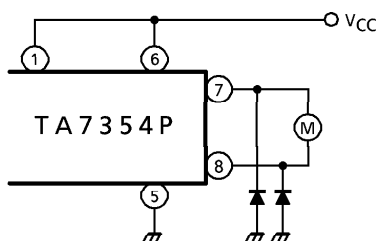

Fig.3

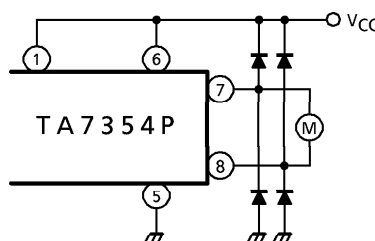
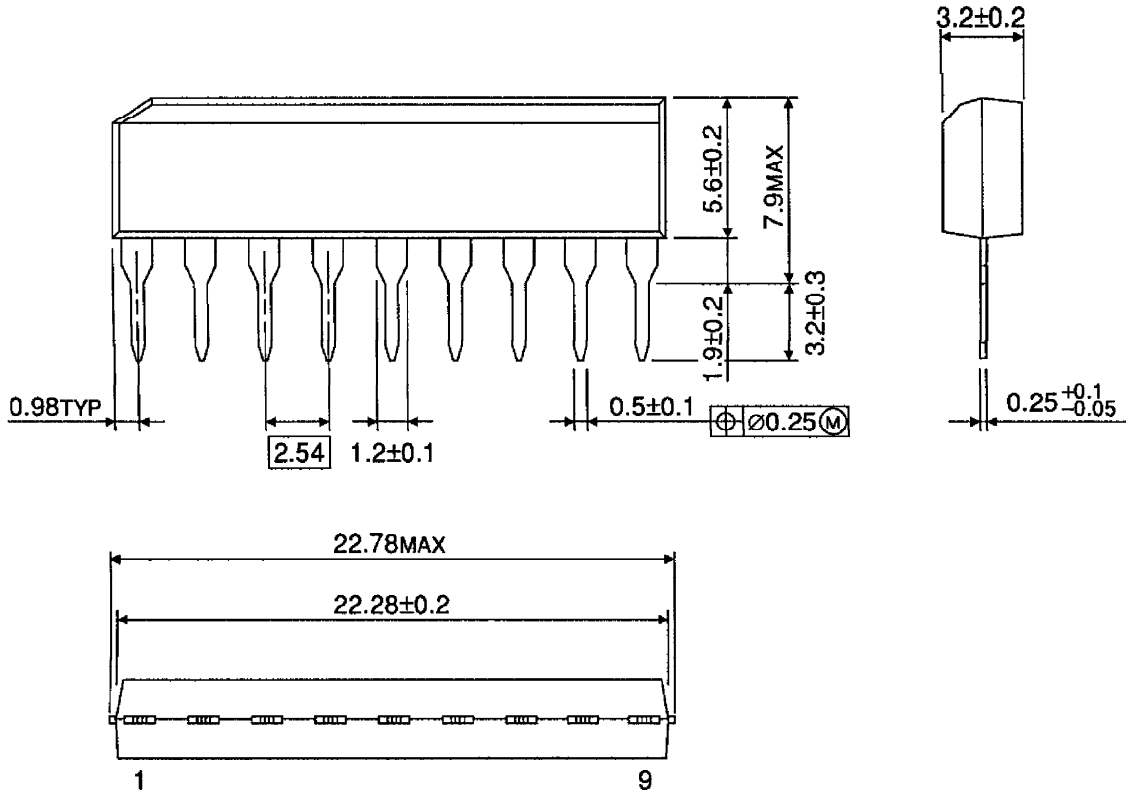

Fig.4

- (4) Utmost care is necessary in the design of the output line, V_{CC} and GND line since IC may be destroyed due to short-circuit between outputs, air contamination fault, or fault by improper grounding.

OUTLINE DRAWING
SIP9-P-2.54A

Unit : mm



Weight : 0.92g (Typ.)