

TA7611AP LINEAR INTEGRATED CIRCUIT

FM IF/AM TUNER SYSTEM

DESCRIPTION

The Contek TA7611AP is a monolithic integrated circuit, designed for the VIF stage in color and B/W TV receiver. The UTC TA7611AP is used for Forward AGC type.

FEATURES

- *High gain wide band IF amplifier
- *Gain reduction with excellent stability
- *Excellent DG/DP and S/N characteristics
- *Negative video output signal
- *Fast AGC action due to noise inverter and peak AGC
- *Switch off the video part VTR SW

FUNCTIONS

- *Three controlled IF amplifier stages
- *Video demodulator controlled by picture carrier
- *Black noise and white noise inverter
- *Peak AGC
- *DC amplifier for RF AGC output
- *Quadrature detector for AFT
- *DC amplifier for AFT

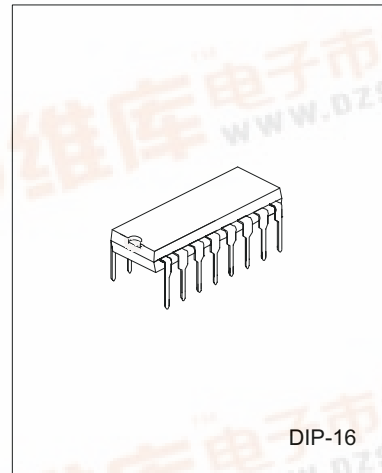

BLOCK DIAGRAM

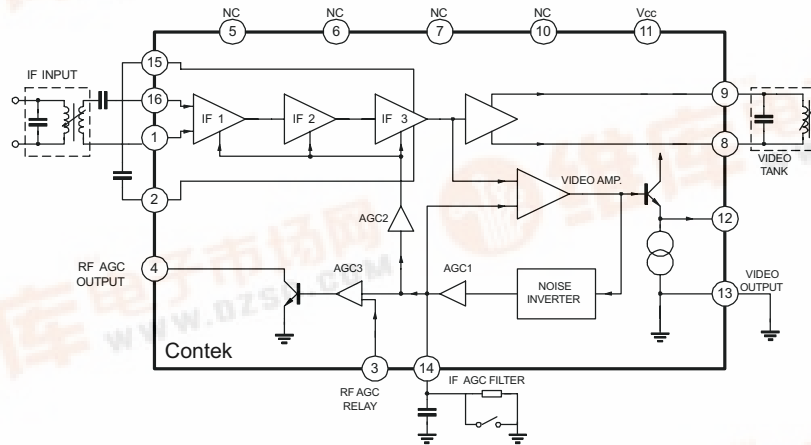

Contek Microelectronics Co.,Ltd.

<http://www.contek-ic.com> E-mail:sales@contek-ic.com



TA7611AP LINEAR INTEGRATED CIRCUIT

ABSOLUTE MAXIMUM RATINGS(Ta=25 C)

PARAMETER	SYMBOL	VALUE	UNIT
Supply Voltage	VCC	15	V
Open Loop Voltage	V4	15	V
Video DC Output Current	I12	6	MA
Power Dissipation	PD	1.4	W
Operating Temperature	TOPR	-20 ~ +65	C
Storage Temperature	TSTG	-55 ~ +150	C

ELECTRICAL CHARACTERISTICS(Ta=25 C, Vcc=12V, fo=45.75MHz, unless otherwise specified)

PARAMETER	SYMBOL	TEST CONDITIONS	MIN.	TYP.	MAX.	UNIT
Recommended Supply Voltage	VCC		10.8	12	13.2	V
Quiescent Circuit Current	ICCQ		42	51	63	mA
Video DC Output	V12		5.2	5.5	5.8	V
AFT DC Output Voltage	V5-V6	SW1: on,SW2: on	5.3	6.8	8.3	V
AFT Output Offset Voltage	V5-V6	SW1: on,SW2: on	-1.5	0	1.5	V
RF AGC Residual Output Voltage	V4(SAT)	SW4:1			0.5	V
RF AGC Leak Current	I4(LEAK)	VCC=12V,SW3:1,SW4:1			1	μA
Video Sensitivity	S _{VI}	V12=0.8VP-P f0=45.75MHZ,AM=30%	100	200	300	μVrms
AGC Range	VAGC (IF)	VCC=12V,f0=45.75MHZ V14=11.5V 4.0V	60	64		dB
Sync Tip Level Voltage (pin12)	VSYNC		2.3	2.5	2.7	V
Maximum IF Input Voltage	V _{I(MAX)}		100	120		mVrms
White Noise Threshold (pin12)	V _{WTH}		5.8	6.2	6.6	V
White Noise Clamp Level (pin12)	V _{WCL}		3.7	4.1	4.5	V
Black Noise Threshold (pin12)	V _{BTH}		1.4	1.6	1.8	V
Black Noise Clamp Level (pin12)	V _{BCL}		2.9	3.3	3.7	V
Video Frequency Response	GV(IF)	Input 45.75MHz, Sweep Generator	4.5	5.5		MHz
Suppression of Carrier	CL	SG1=100mVrms SG2, SG3->OFF	40	50		dB
Suppression of 2 nd Carrier	I2ND	SG1=100mVrms SG2, SG3->OFF	40	50		dB
920KHz Beat Level	I920	SG1=100mVrms SG2=SG3=32mVrms	33	38		dB
Differential Gain	DG			7	10	dB
Differential Phase	DP			3.5	5	Degree
Input Impedance	RIN CIN	fo=45.75MHz, Between pin16~1	3.0	4.5 2	6 5	K pF
AFT Output Upper Voltage	V5,V6(UP)		11.7	11.9	12	V
AFT Output Lower Voltage	V5,V6(LOW)		1.8	2.3	2.8	V
Maximum Available Current	I4(MAX)		7			mA
AFT Sensitivity	S _{AFT}			16		KHz/V



Contek Microelectronics Co.,Ltd.

<http://www.contek-ic.com> E-mail:sales@contek-ic.com

TA7611AP LINEAR INTEGRATED CIRCUIT

TEST CIRCUIT 1

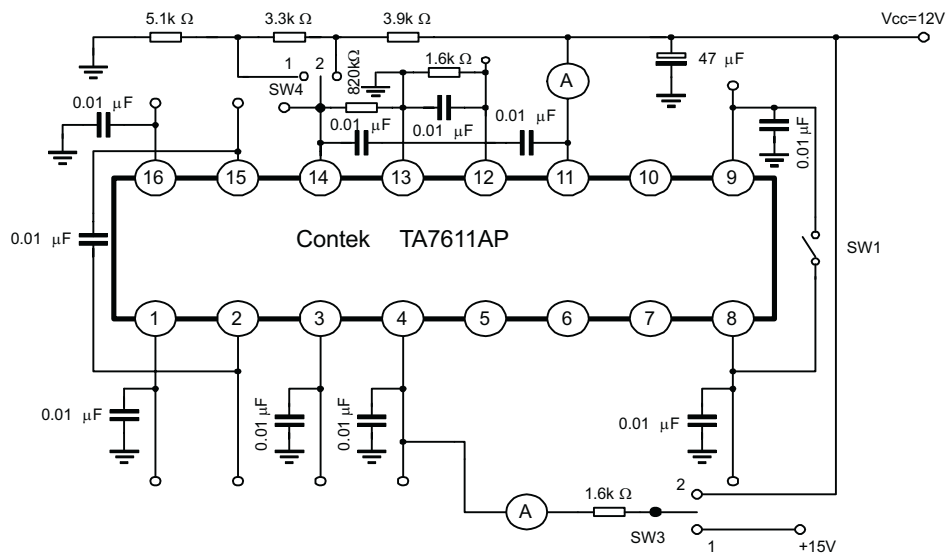

TEST CIRCUIT 2

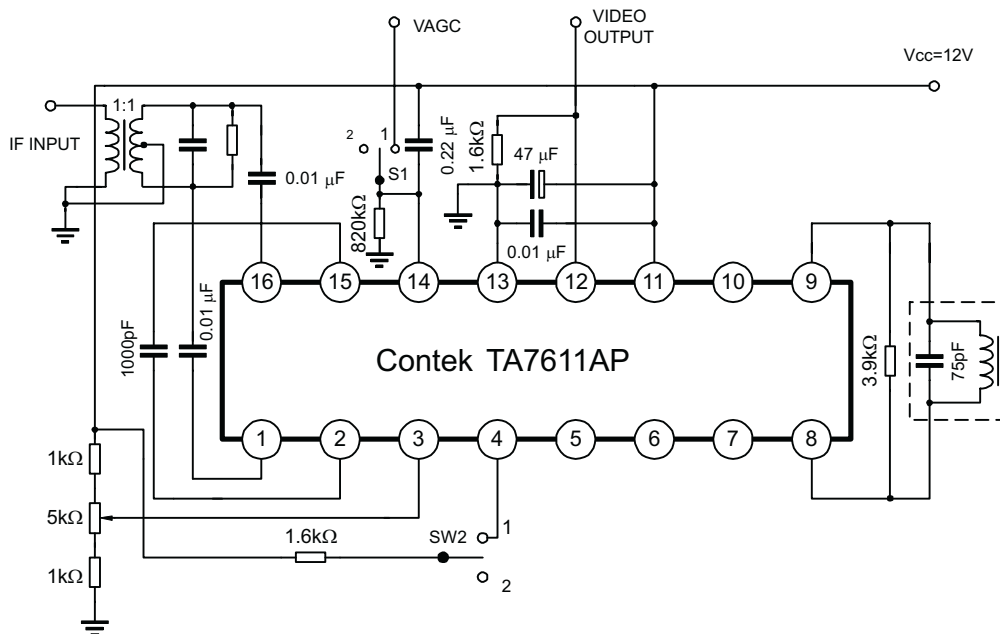

Contek Microelectronics Co.,Ltd.

<http://www.contek-ic.com> E-mail:sales@contek-ic.com

TA7611AP LINEAR INTEGRATED CIRCUIT

TEST CIRCUIT 3

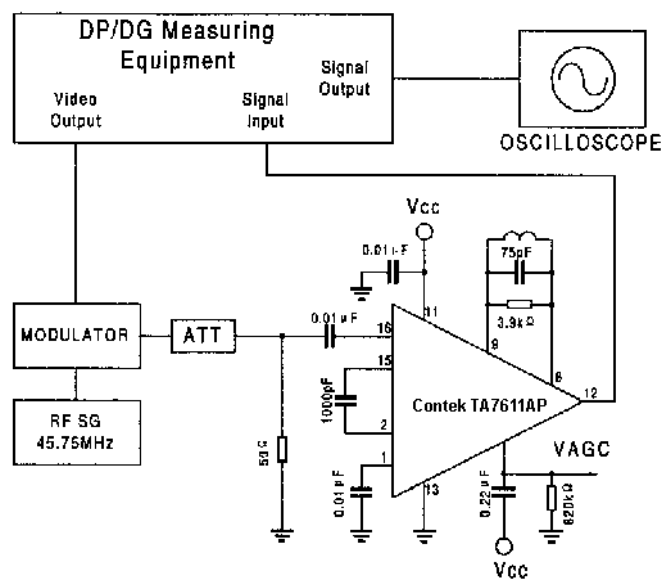

TEST CIRCUIT 4

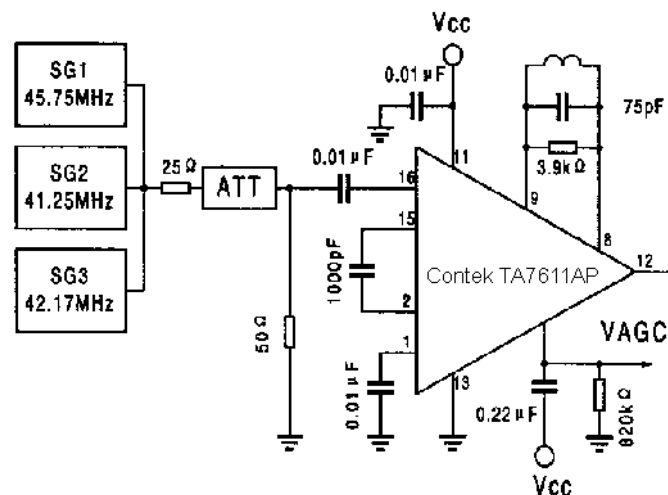

Contek Microelectronics Co.,Ltd.

<http://www.contek-ic.com> E-mail:sales@contek-ic.com

TA7611AP LINEAR INTEGRATED CIRCUIT

TYPICAL APPLICATION CIRCUIT

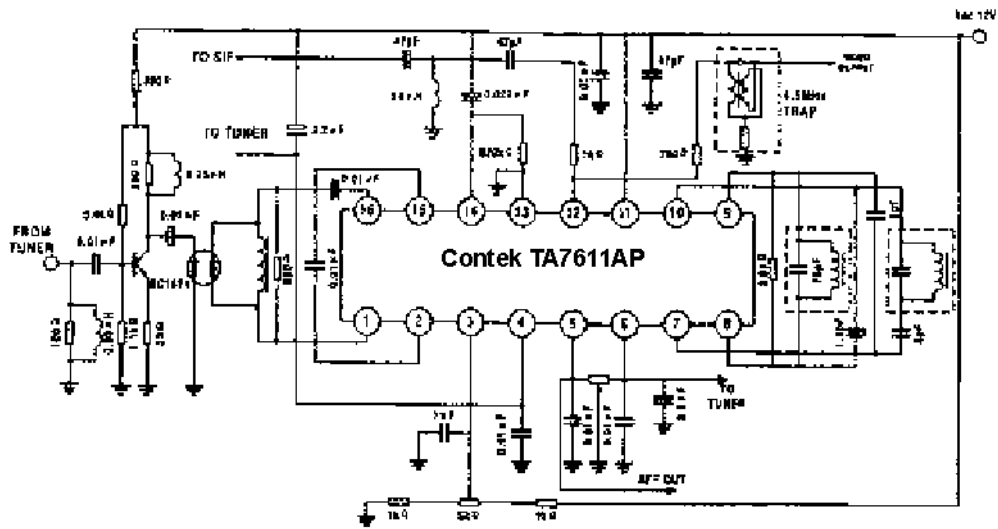

Contek Microelectronics Co., Ltd.

<http://www.contek-ic.com> E-mail: sales@contek-ic.com