

TOSHIBA

TA7709P/F

TOSHIBA BIPOLAR LINEAR INTEGRATED CIRCUIT SILICON MONOLITHIC

TA7709P, TA7709F

DUAL PREAMPLIFIERS (3V USE)

The TA7709P and TA7709F are dual preamplifier designed for use in a playback amplifier of low voltage operating tape recorder.

It consists of two channels preamplifier and two transistors of collector common grounded.

They are prepared two type package. (FLAT and Dual In-line package)

FEATURES

- High voltage gain at open loop.
: $G_{VO} = 85\text{dB}$ (Typ.) ($V_{CC} = 3\text{V}$, $f = 1\text{kHz}$)
- Non-necessary the input coupling condensers.
- Operating supply voltage range
: $V_{CC} = 1.6\sim 5\text{V}$ ($T_a = 25^\circ\text{C}$)
- TA7709F (SO) is standard model of flat package.

BLOCK DIAGRAM

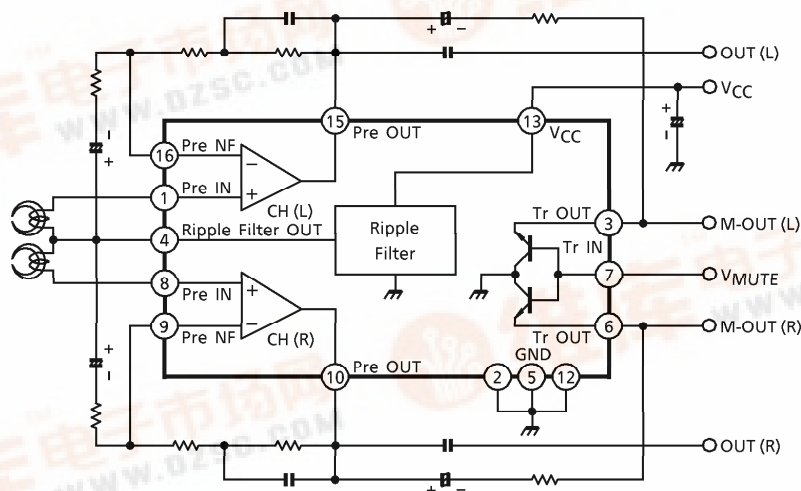

TA7709P

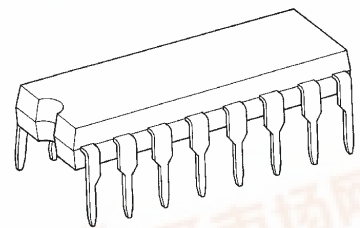

DIP16-P-300-2.54A

TA7709F (SO)

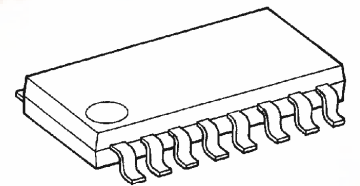

SSOP16-P-225-1.00A

Weight

DIP16-P-300-2.54A : 1.00g (Typ.)
SSOP16-P-225-1.00A : 0.14g (Typ.)

961001EBA2

● TOSHIBA is continually working to improve the quality and the reliability of its products. Nevertheless, semiconductor devices in general can malfunction or fail due to their inherent electrical sensitivity and vulnerability to physical stress. It is the responsibility of the buyer, when utilizing TOSHIBA products, to observe standards of safety, and to avoid situations in which a malfunction or failure of a TOSHIBA product could cause loss of human life, bodily injury or damage to property. In developing your designs, please ensure that TOSHIBA products are used within specified operating ranges as set forth in the most recent products specifications. Also, please keep in mind the precautions and conditions set forth in the TOSHIBA Semiconductor Reliability Handbook.

APPLICATION NOTE

- Input signals can be applied between pin① or ⑧ and pin④ as common without input coupling capacitors.
In case that input signals is applied between pin① or ⑧ and GND terminal, it is necessary that connecting input coupling capacitors, and starting time of amplifiers will increase.
- Test pin① and ④ should not be connected to avoid malfunctions.
- Ripple rejection characteristics are shown in the attached paper. To keep good rejection ratio, a combination of the TA7709P, TA7709F and the TA7688F is recommendable.
In this case, the V_{CC} of the TA7709P, TA7709F is supplied by V_{RF} output of the TA7688F.

MAXIMUM RATINGS ($T_a = 25^\circ\text{C}$)

CHARACTERISTIC		SYMBOL	RATING	UNIT
Supply Voltage		V_{CC}	7	V
Power Dissipation	TA7709P	P_D (Note 1)	750	mW
	TA7709F		350	
Operating Temperature		T_{opr} (Note 2)	-25~75	$^\circ\text{C}$
Storage Temperature		T_{stg}	-55~150	$^\circ\text{C}$

(Note 1) Derated above $T_a = 25^\circ\text{C}$ in the proportion of $6\text{mW}/^\circ\text{C}$ for TA7709P, and of $2.8\text{mW}/^\circ\text{C}$ for TA7709F

(Note 2) At $T_a = -25^\circ\text{C}$, $V_{CC} \geq 1.7\text{V}$

ELECTRICAL CHARACTERISTICS (Unless otherwise specified, $V_{CC} = 3\text{V}$, $f = 1\text{kHz}$, $T_a = 25^\circ\text{C}$)

CHARACTERISTIC	SYMBOL	TEST CIRCUIT	TEST CONDITION	MIN.	TYP.	MAX.	UNIT
Quiescent Current	I_{CCQ}	—	$V_{in} = 0$	—	2.0	3.4	mA
Open Loop Voltage Gain	G_{VO}	—	$V_{in} = -60\text{dBV}$	70	85	—	dB
Maximum Output Voltage	V_{om}	—	THD = 1%	0.5	0.9	—	V_{rms}
Total Harmonic Distortion	THD	—	$V_O = 0.1V_{rms}$	—	0.07	0.5	%
Output Noise Voltage	V_{no}	—	$R_g = 2.2\text{k}\Omega$, $G_V = 40\text{dB}$ BPF = 50Hz~20kHz	—	0.14	0.22	mV_{rms}
Cross Talk	CT	—	$R_g = 600\Omega$, $V_O = -10\text{dBV}$	—	60	—	dB
Muting Attenuation	ATT	—	$V_{MUTE} = 1\text{V}$	—	43	—	dB
Input Resistance	R_{IN}	—	—	20	30	—	$\text{k}\Omega$

961001EBA2'

- The products described in this document are subject to foreign exchange and foreign trade control laws.
- The information contained herein is presented only as a guide for the applications of our products. No responsibility is assumed by TOSHIBA CORPORATION for any infringements of intellectual property or other rights of the third parties which may result from its use. No license is granted by implication or otherwise under any intellectual property or other rights of TOSHIBA CORPORATION or others.
- The information contained herein is subject to change without notice.

DC CHARACTERISTICS

($V_{CC} = 3V$, $T_a = 25^\circ C$, Terminal voltage at no signal)

PIN No.	ITEM	SYMBOL	TYP.	UNIT
1	Pre IN	V_1	1.35	V
2	GND	V_2	0	V
3	Tr-OUT	V_3	—	V
4	Ripple Filter OUT	V_4	1.36	V
5	GND	V_5	0	V
6	Tr-OUT	V_6	—	V
7	Tr-IN	V_7	—	V
8	Pre IN	V_8	1.35	V
9	Pre NF	V_9	1.35	V
10	Pre OUT	V_{10}	1.44	V
11	TEST Pin	V_{11}	—	V
12	GND	V_{12}	0	V
13	V_{CC}	V_{13}	3.0	V
14	TEST Pin	V_{14}	—	V
15	Pre OUT	V_{15}	1.44	V
16	Pre NF	V_{16}	1.35	V

TEST CIRCUIT

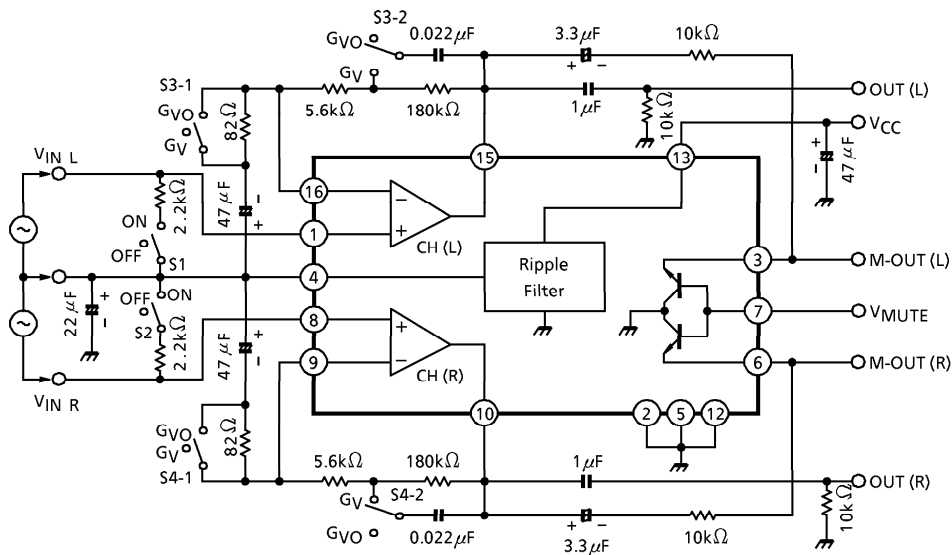

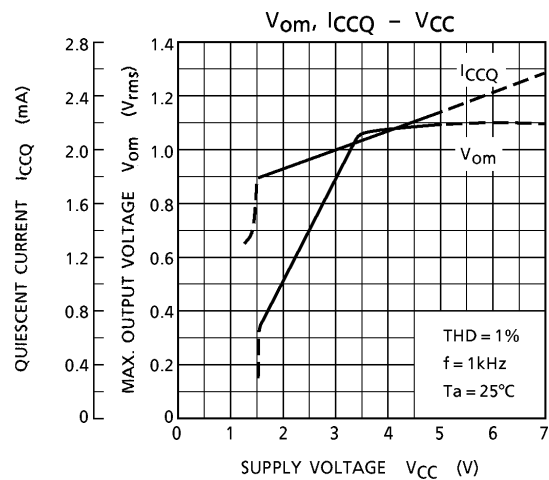
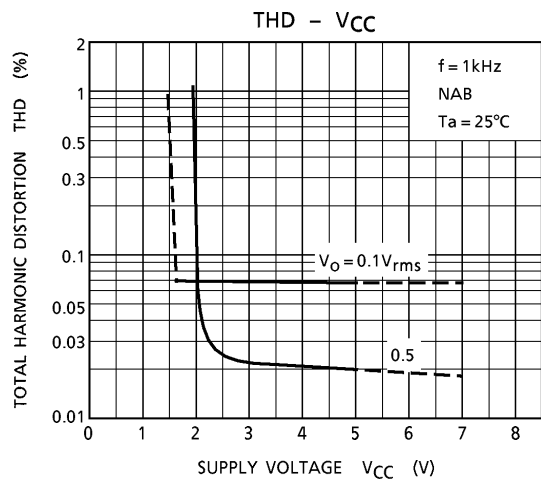
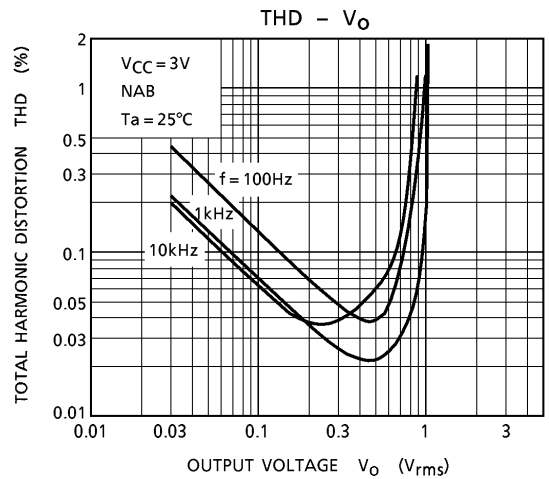
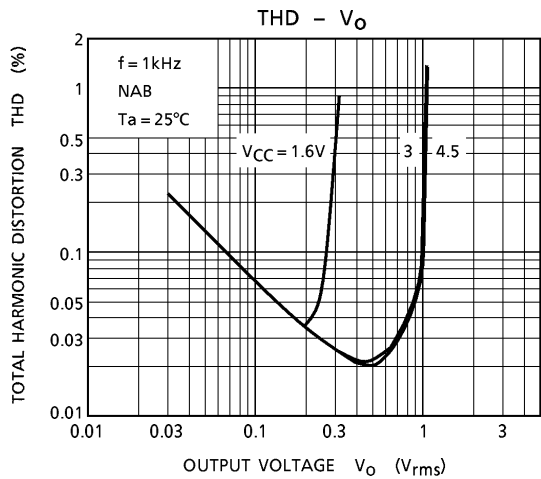
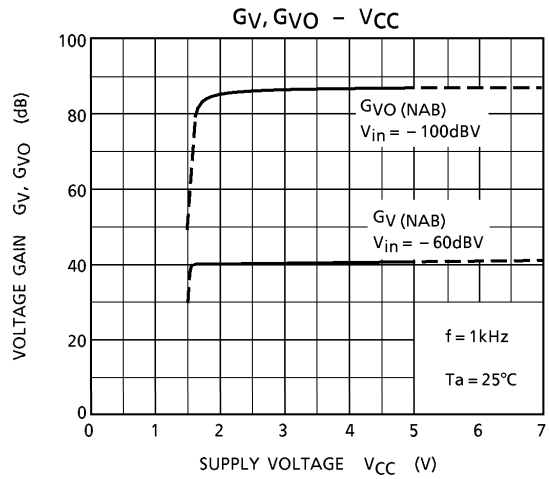
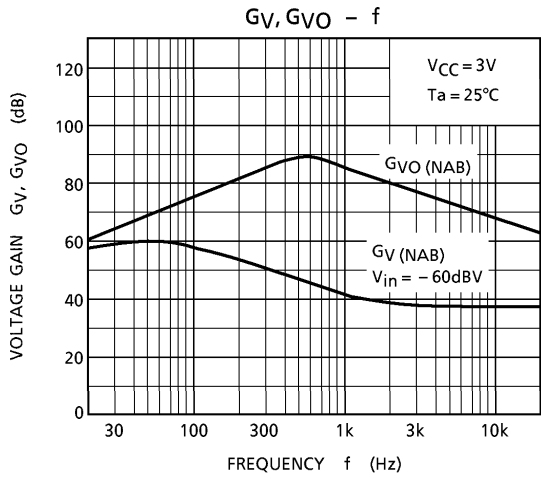

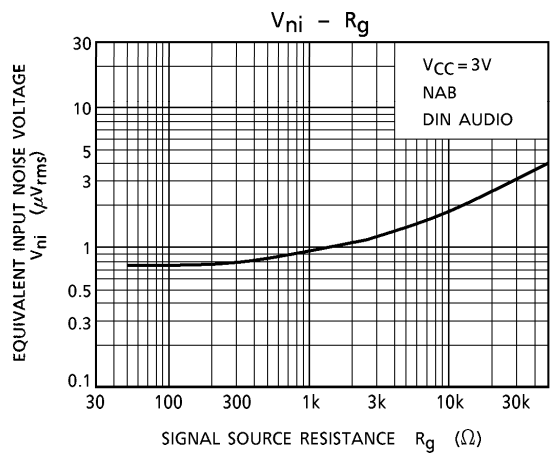
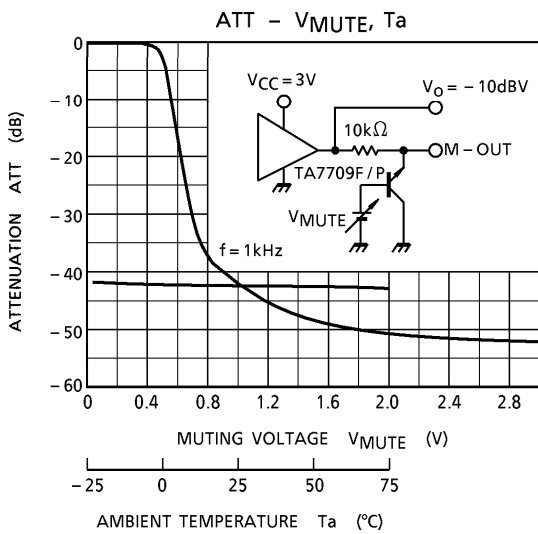
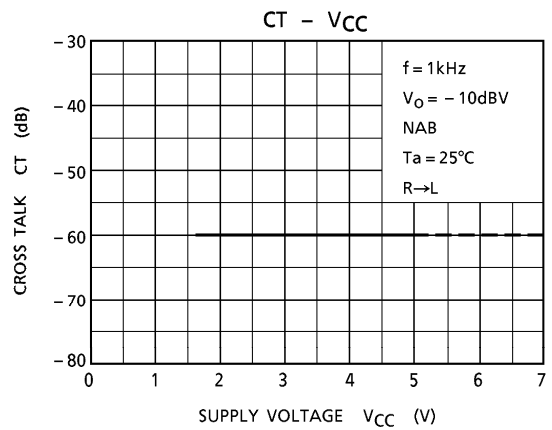
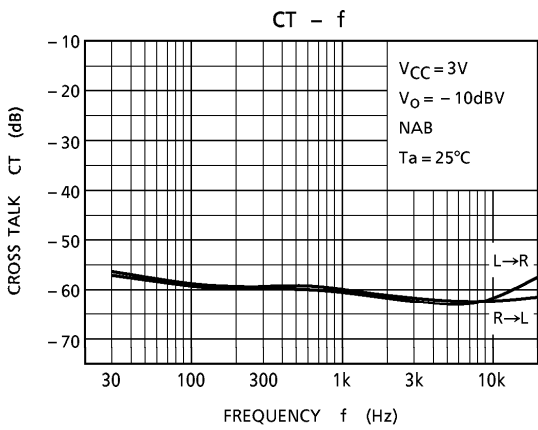
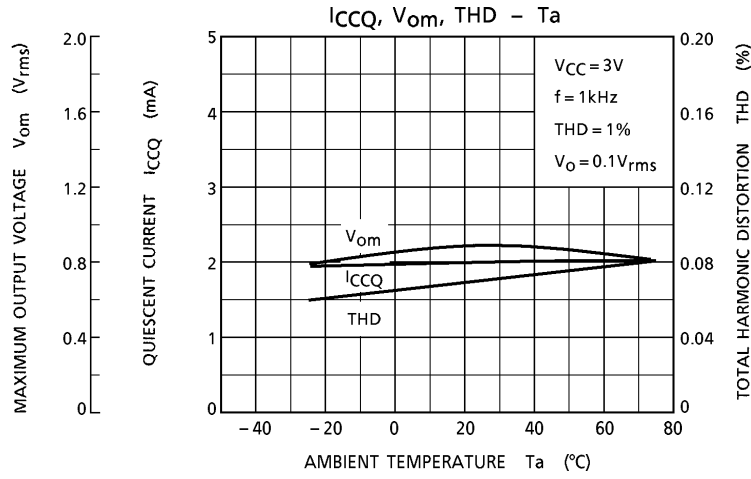

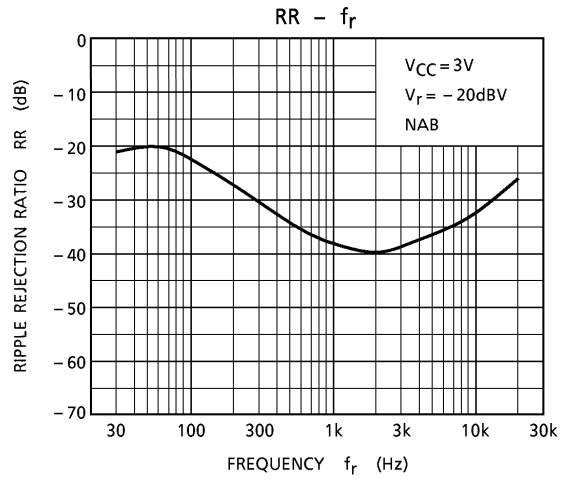
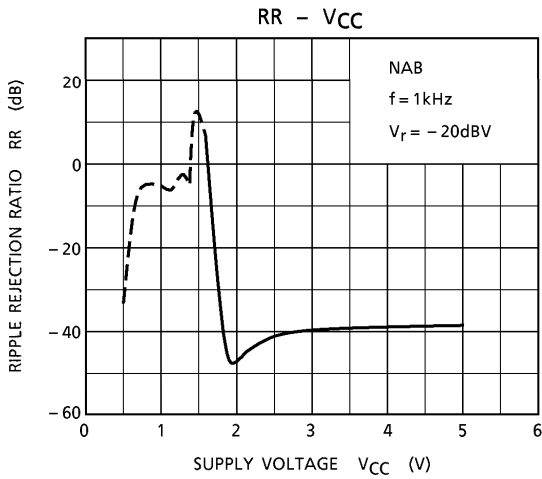

APPLICATION CIRCUIT

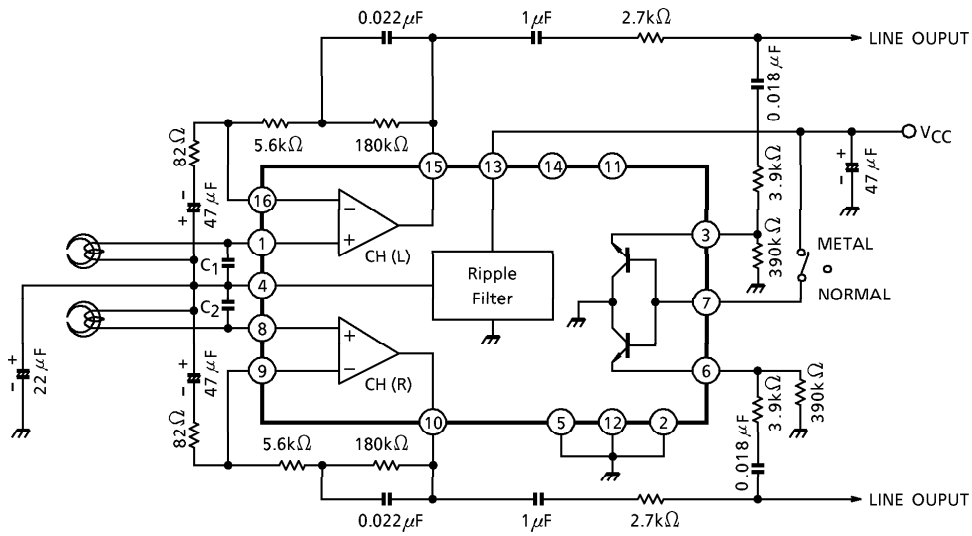

(Note) Capacitor C₁ and C₂ may be required for preventing a instability caused by the pattern layout or interference of external high frequency signal.

OUTLINE DRAWING
DIP16-P-300-2.54A

Unit : mm

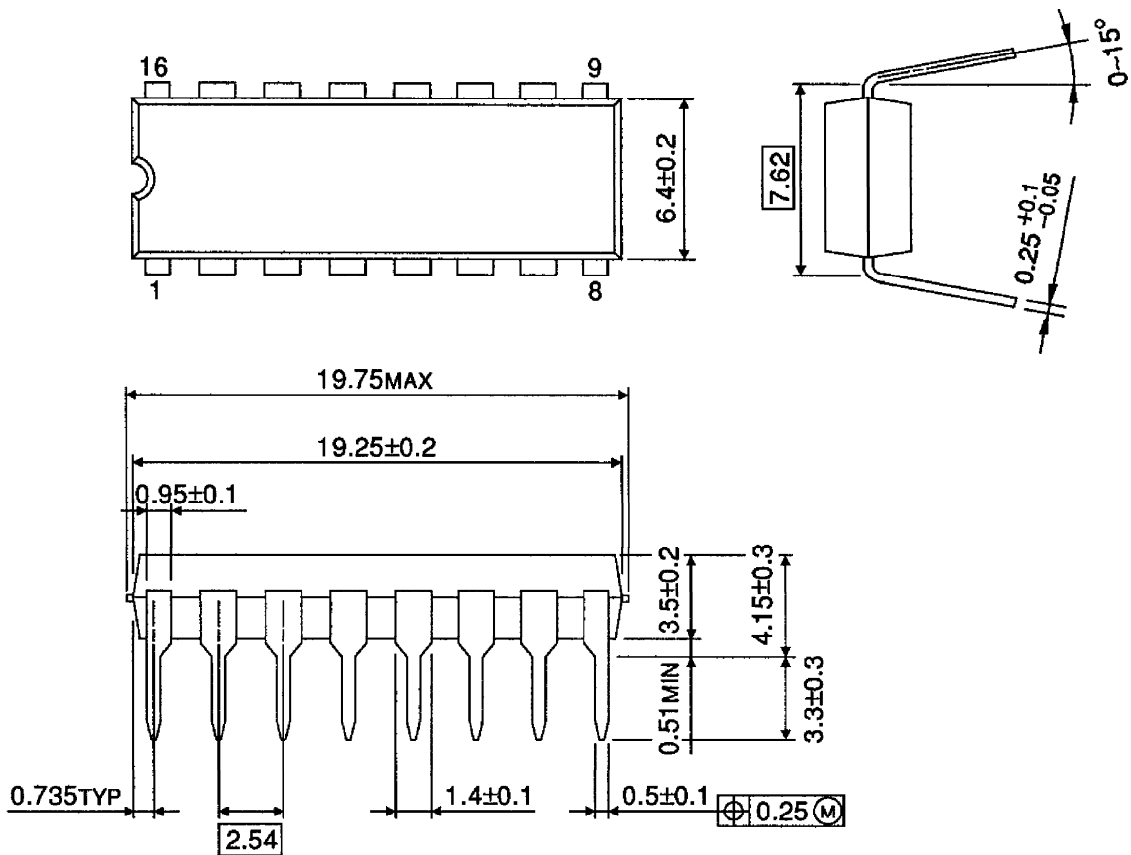

Weight : 1.00g (Typ.)

OUTLINE DRAWING
SSOP16-P-225-1.00A

Unit : mm

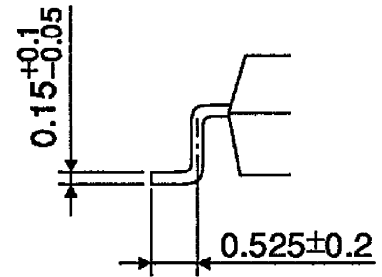
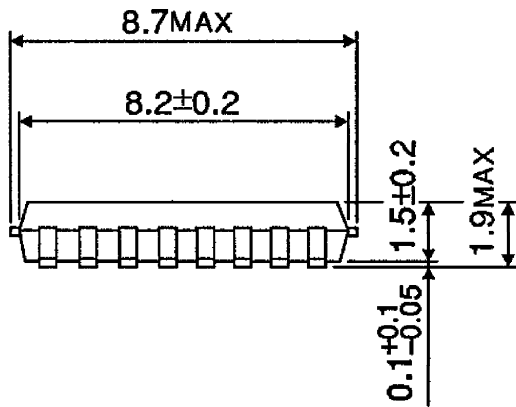
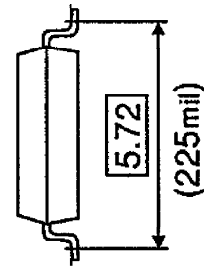
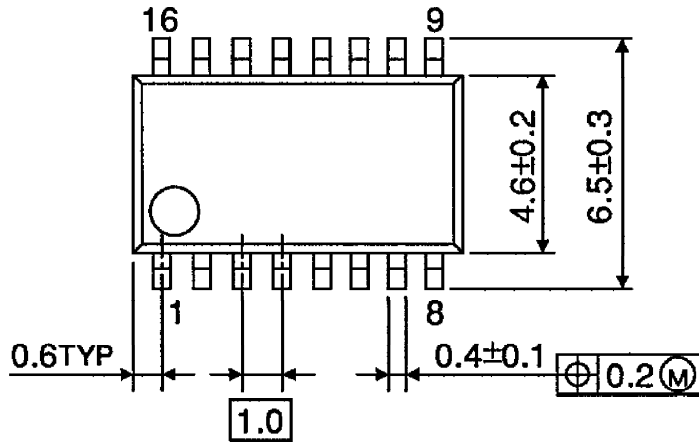

Weight : 0.14g (Typ.)