

**TOSHIBA**

**TA8200AH**

TOSHIBA BIPOLAR LINEAR INTEGRATED CIRCUIT SILICON MONOLITHIC

# TA8200AH

## DUAL AUDIO POWER AMPLIFIER

The TA8200AH is dual audio power amplifier for consumer applications.

This IC provides an output power of 13 watts per channel (at  $V_{CC} = 28V$ ,  $f = 1kHz$ ,  $THD = 10\%$ ,  $R_L = 8\Omega$ ). It is suitable for power amplifier of TV and home stereo.

### FEATURES

- High Output Power :  $P_{Out} = 13W$  / channel (Typ.)  
( $V_{CC} = 28V$ ,  $R_L = 8\Omega$ ,  $f = 1kHz$ ,  $THD = 10\%$ )
- Low Noise :  $V_{nO} = 0.14mV_{rms}$  (Typ.)  
( $V_{CC} = 28V$ ,  $R_L = 8\Omega$ ,  $G_V = 34dB$ ,  $R_g = 10k\Omega$ ,  $BW = 20Hz \sim 20kHz$ )
- Very Few External Parts.
- Built in Audio Muting Circuit.
- Built in Thermal Shut Down Protector Circuit.
- Operating Supply Voltage Range :  $V_{CC} (opr) = 10 \sim 37V$  ( $T_a = 25^\circ C$ )

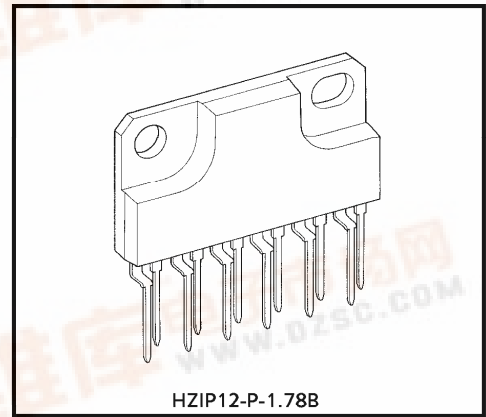

HZIP12-P-1.78B

Weight : 4.04g (Typ.)

### BLOCK DIAGRAM

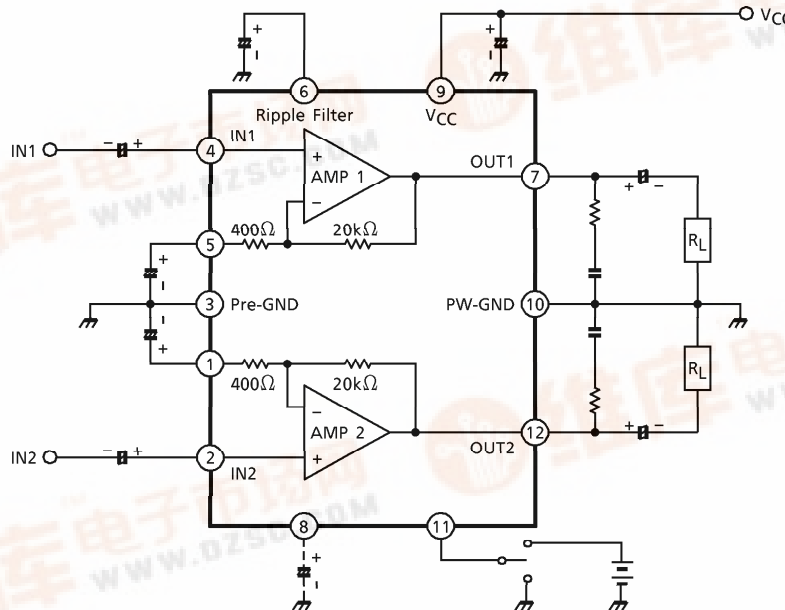

961001EBA2

● TOSHIBA is continually working to improve the quality and the reliability of its products. Nevertheless, semiconductor devices in general can malfunction or fail due to their inherent electrical sensitivity and vulnerability to physical stress. It is the responsibility of the buyer, when utilizing TOSHIBA products, to observe standards of safety, and to avoid situations in which a malfunction or failure of a TOSHIBA product could cause loss of human life, bodily injury or damage to property. In developing your designs, please ensure that TOSHIBA products are used within specified operating ranges as set forth in the most recent products specifications. Also, please keep in mind the precautions and conditions set forth in the TOSHIBA Semiconductor Reliability Handbook.



**APPLICATION INFORMATION**

(1) Voltage gain

The closed loop voltage gain is determined by  $R_1$ ,  $R_2$ .

$$G_V = 20 \log \frac{R_1 + R_2}{R_2} \text{ (dB)}$$

$$= 20 \log \frac{20\text{k}\Omega + 400\Omega}{400\Omega} = 34 \text{ (dB)}$$

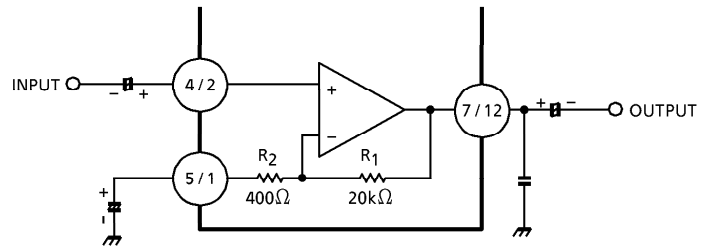

Fig.1

(2) Amplifier with gain < 34dB

$$G_V = 20 \log \frac{R_1 + R_2 + R_3}{R_2 + R_3} \text{ (dB)}$$

When  $R_3 = 220\Omega$

$$G_V \doteq 30 \text{ (dB)}$$

is given.

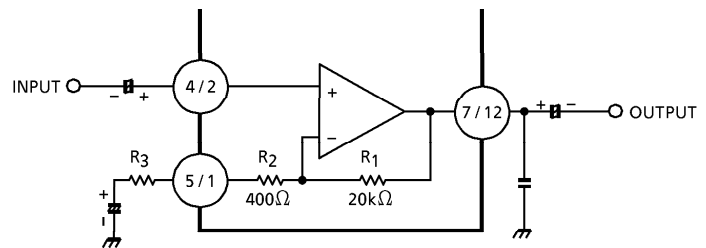

Fig.2

961001EBA2'

● The products described in this document are subject to foreign exchange and foreign trade control laws.  
 ● The information contained herein is presented only as a guide for the applications of our products. No responsibility is assumed by TOSHIBA CORPORATION for any infringements of intellectual property or other rights of the third parties which may result from its use. No license is granted by implication or otherwise under any intellectual property or other rights of TOSHIBA CORPORATION or others.  
 ● The information contained herein is subject to change without notice.

2. Muting

(1) Audio muting

This IC is possible to make audio muting operation by using ⑪pin muting terminal. In Fig.3, the equivalent circuit in the muting circuit section is shown.

By means of reducing the voltage of ⑪pin down to 2.8V or less in Fig.3, Q<sub>1</sub> is turned ON and the base voltage of Q<sub>2</sub> in the differential circuit fabricated with Q<sub>2</sub> and Q<sub>3</sub>. Therefore, with the voltage reduction of ⑪pin, the input circuits of dummy of input terminal and that in the dotted line operate and cut-off the input signal.

After muting, the bias circuit continues its operation and the power supply current of quiescent time.

⑧pin, the capacitor terminal for reducing the pop noise can reduce the pop noise through making the time constant longer by means of inserting the capacitor externally.

In the case this terminal is not used, short ⑧pin with ⑪pin.

The voltage of ⑪pin set up to 4V or more.

(2) IC internal muting at V<sub>CC</sub> OFF

When V<sub>CC</sub>=8V or less at V<sub>CC</sub> off, the detection circuit at V<sub>CC</sub> off is operated. And the base voltage of Q<sub>1</sub> is reduced and the muting operation is mode.

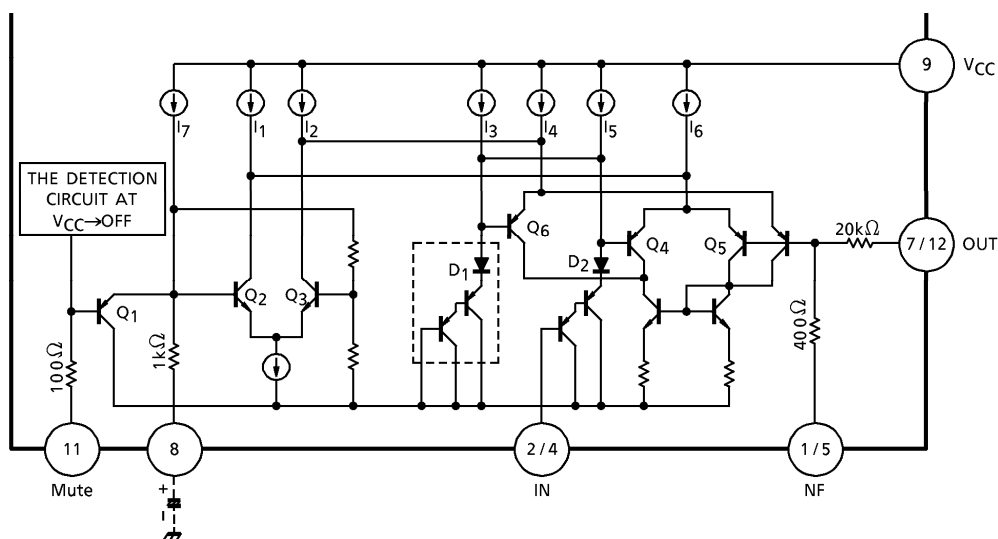
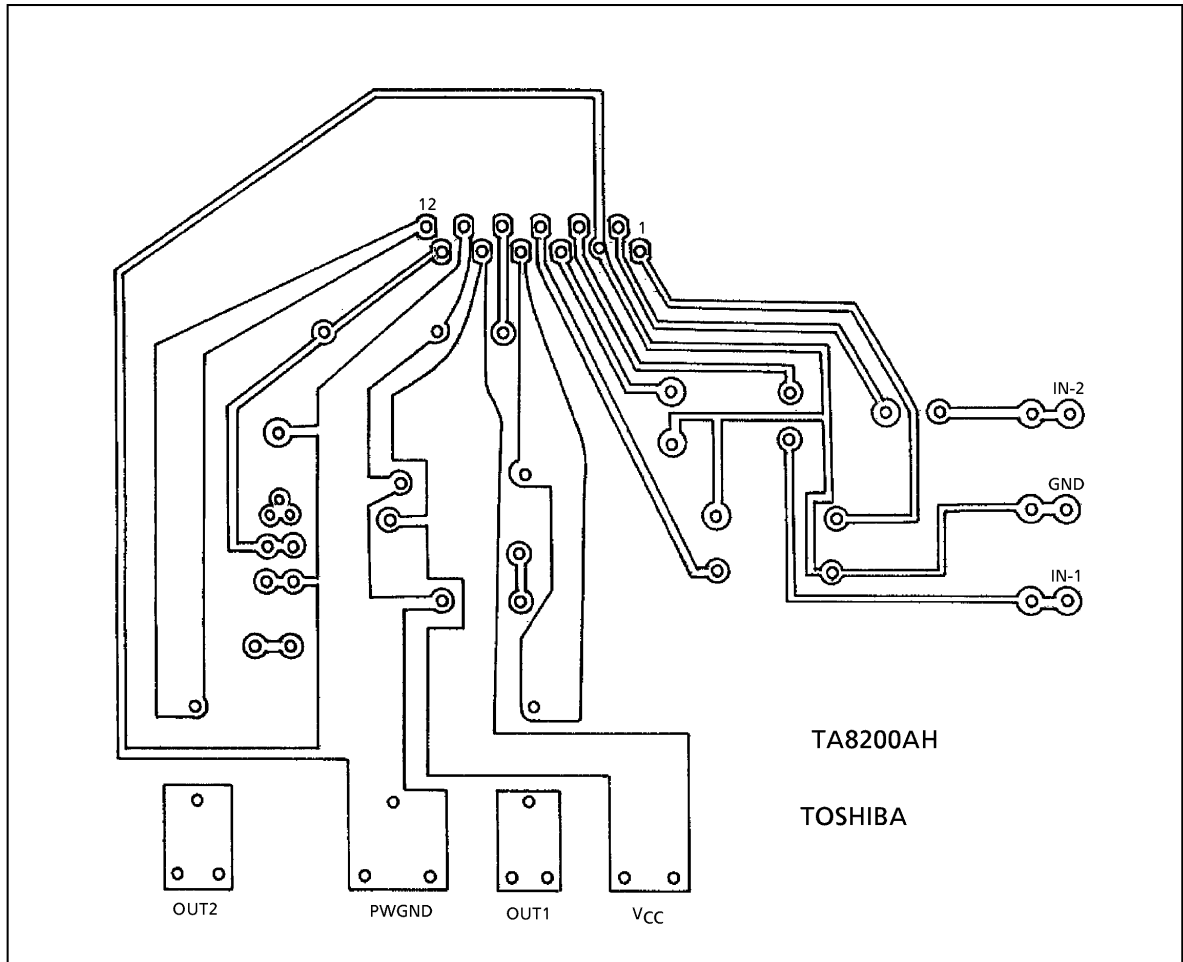

Fig.3

(3) Standard PCB TA8200AH



(BOTTOM VIEW)

**MAXIMUM RATINGS** (Ta = 25°C)

CHARACTERISTIC	SYMBOL	RATING	UNIT
Supply Voltage	V <sub>CC</sub>	37	V
Output Current (Peak / Ch)	I <sub>O (peak)</sub>	2.5	A
Power Dissipation	P <sub>D</sub> (Note)	25	W
Operating Temperature	T <sub>opr</sub>	-20~75	°C
Storage Temperature	T <sub>stg.</sub>	-55~150	°C

(Note) Derated above Ta = 25°C in the proportion of 200mW/°C.

**ELECTRICAL CHARACTERISTICS**

(Unless otherwise specified, V<sub>CC</sub> = 28V, R<sub>L</sub> = 8Ω, R<sub>G</sub> = 600Ω, f = 1kHz, Ta = 25°C)

CHARACTERISTIC	SYMBOL	TEST CIR-CUIT	TEST CONDITION	MIN.	TYP.	MAX.	UNIT
Quiescent Current	I <sub>CCQ</sub>	—	V <sub>in</sub> = 0	—	50	105	mA
Output Power	P <sub>out</sub> (1)	—	THD = 10%	10	13	—	W
	P <sub>out</sub> (2)	—	THD = 1%	—	10	—	
Total Harmonic Distortion	THD	—	P <sub>out</sub> = 2W	—	0.04	0.2	%
Voltage Gain	G <sub>V</sub>	—	V <sub>out</sub> = 0.775V <sub>rms</sub> (0dBm)	32.5	34.0	35.5	dB
Input Resistance	R <sub>IN</sub>	—	—	—	30	—	kΩ
Ripple Rejection Ratio	R.R.	—	R <sub>g</sub> = 0, f <sub>ripple</sub> = 100Hz V <sub>ripple</sub> = 0.775V <sub>rms</sub> (0dBm)	-40	-50	—	dB
Output Noise Voltage	V <sub>no</sub>	—	R <sub>g</sub> = 10kΩ, BW = 20Hz~20kHz	—	0.14	0.3	mV <sub>rms</sub>
Cross Talk	C.T.	—	R <sub>g</sub> = 10kΩ, V <sub>out</sub> = 0.775V <sub>rms</sub> (0dBm)	—	-70	—	dB
Muting Threshold Voltage	V <sub>th</sub> ①	—	—	2.6	2.8	—	V

**TYP. DC VOLTAGE OF EACH TERMINAL** (V<sub>CC</sub> = 28V, Ta = 25°C)

TERMINAL No.	1	2	3	4	5	6	7	8	9	10	11	12
DC Voltage (V)	1.6	20m	GND	20m	1.6	9.4	13.0	5.0	V <sub>CC</sub>	GND	2.8	13.0

TEST CIRCUIT

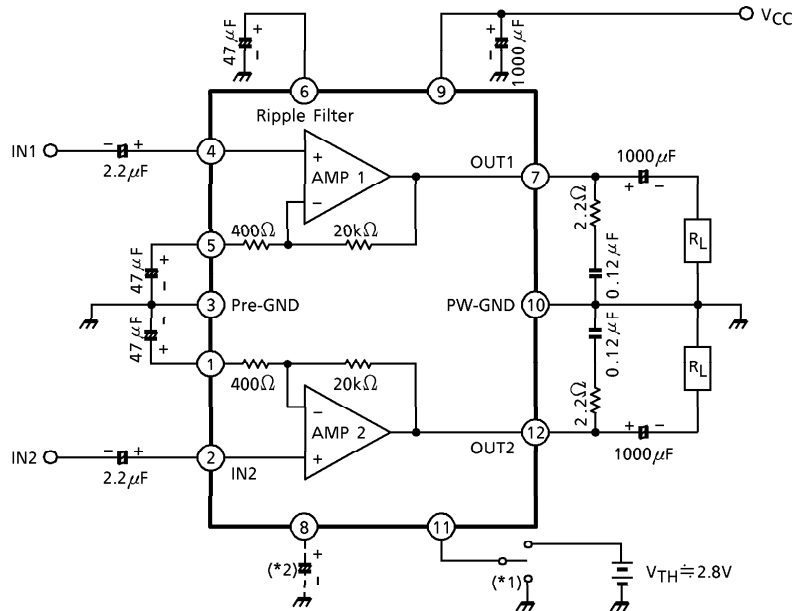

- (\*1) Mute on at ①pin low  
 $V_{TH} = 2.8V$  (Typ.),  $V_{CC} = 28V$ ,  $T_a = 25^\circ C$
- (\*2) The capacitor for reducing POP noise at mute ON.

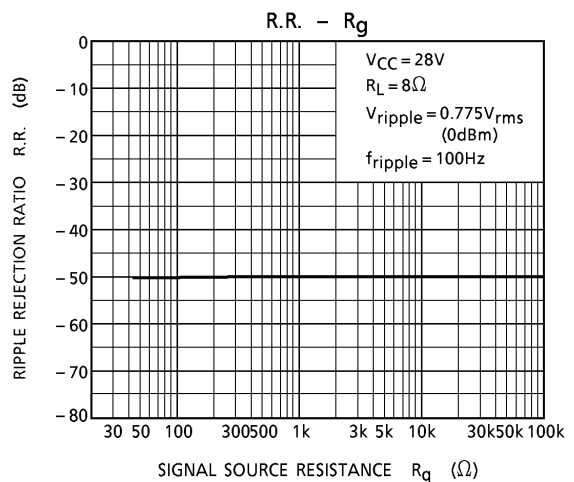
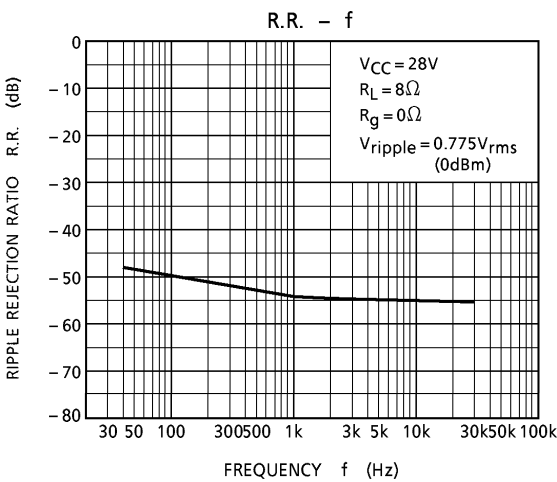
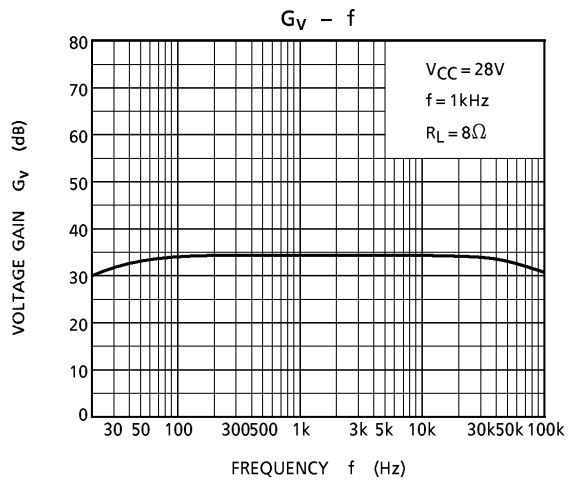
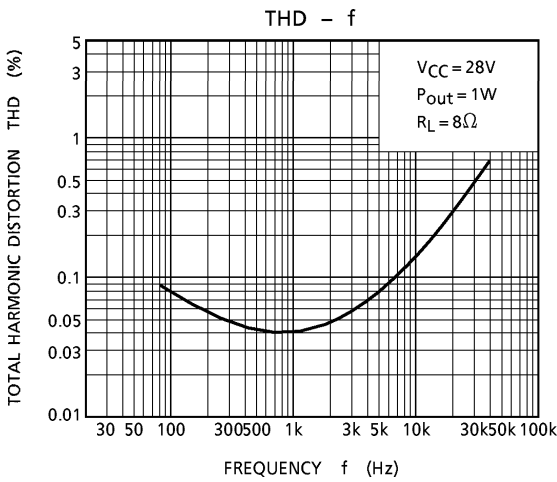
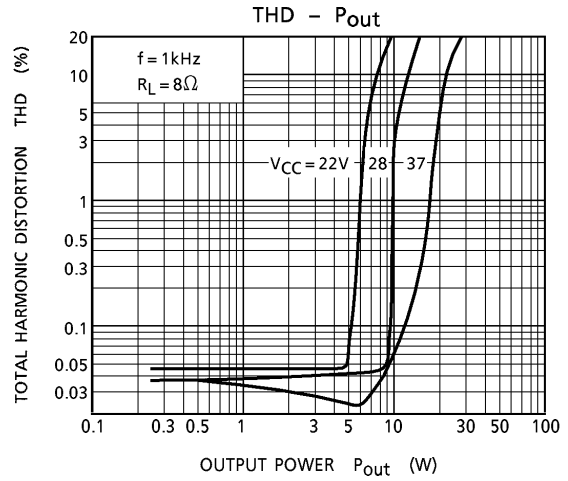
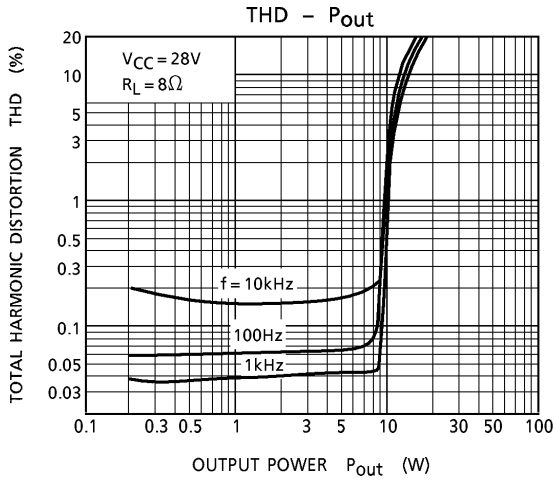

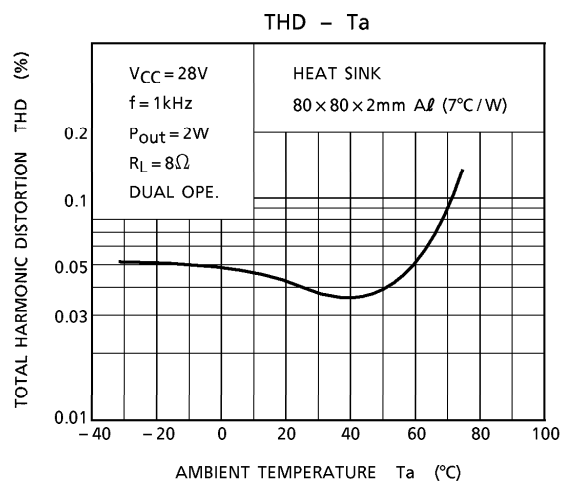
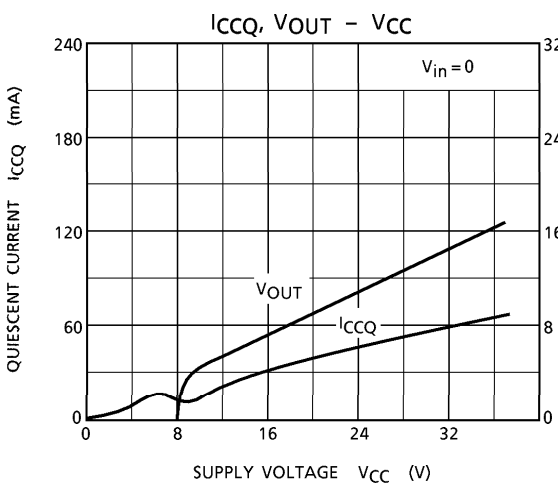
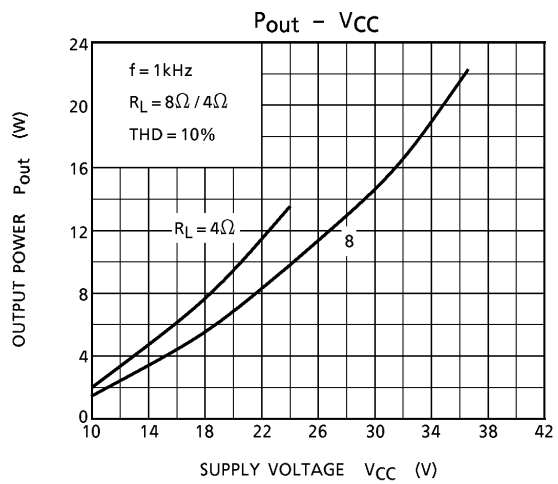
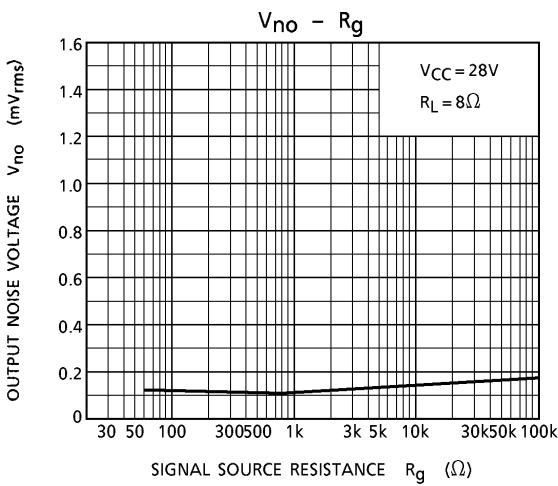
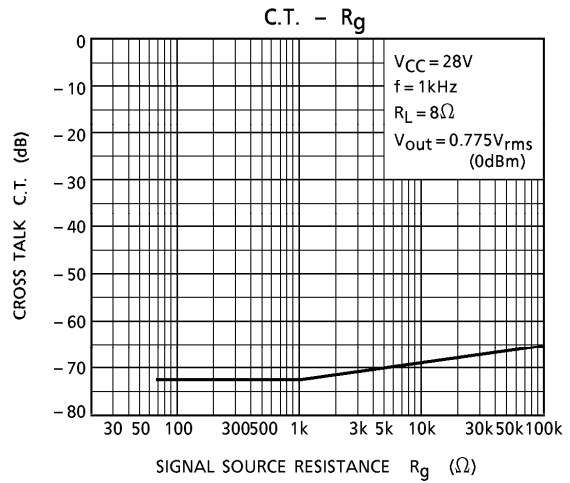
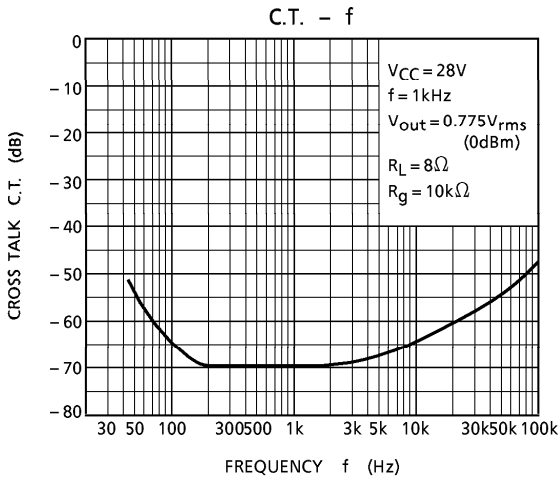



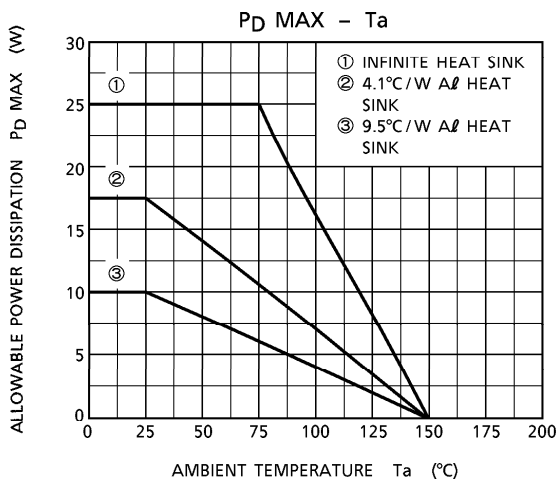
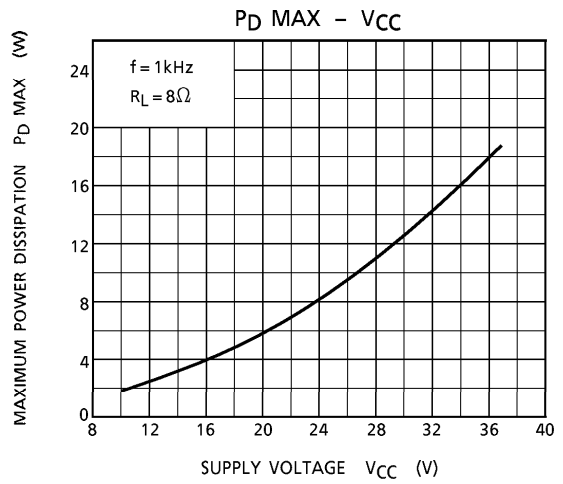
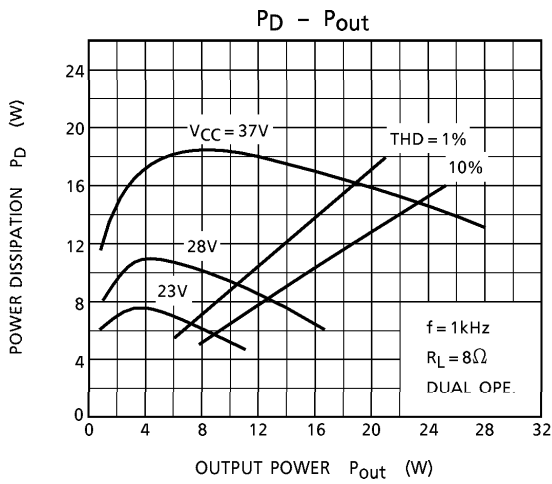
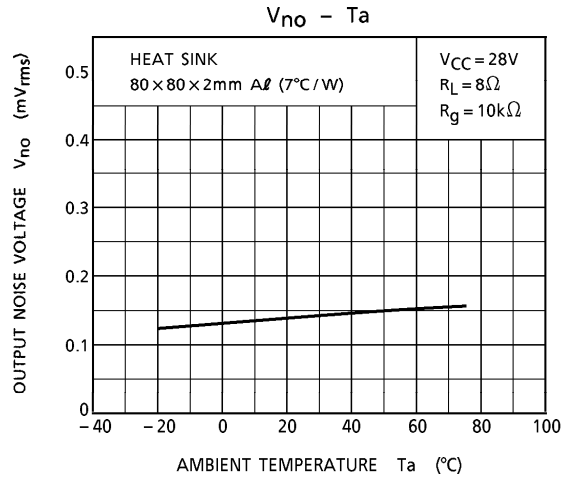
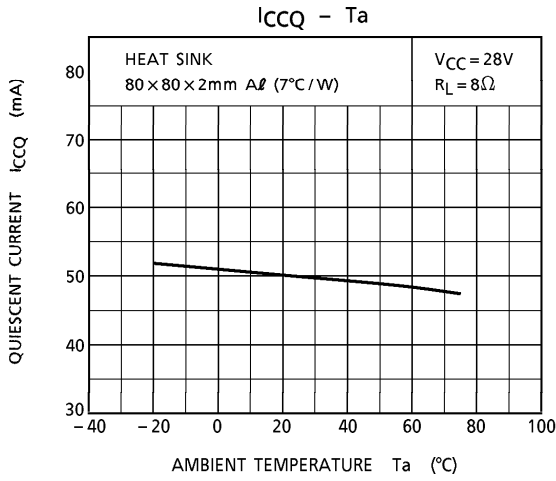

OUTLINE DRAWING  
HZIP12-P-1.78B

Unit : mm

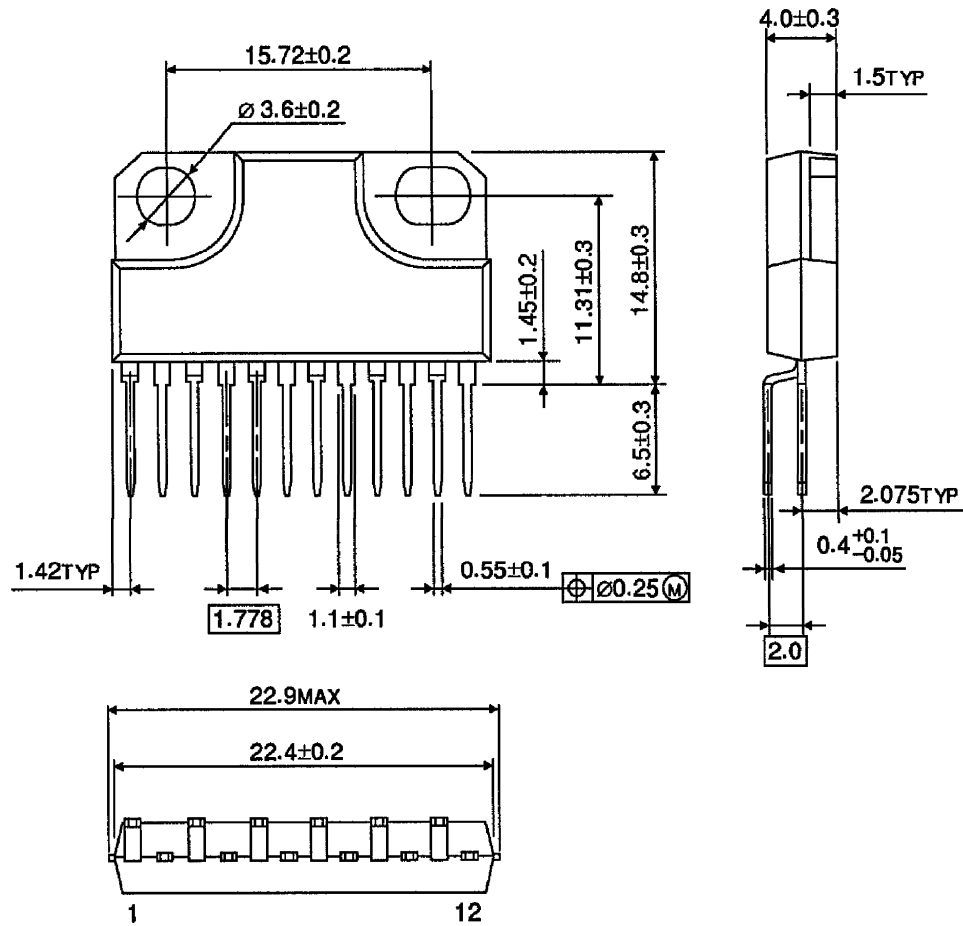

Weight : 4.04g (Typ.)