

TOSHIBA

TA8214K

TOSHIBA BIPOLAR LINEAR INTEGRATED CIRCUIT SILICON MONOLITHIC

TA8214K

MULTI OUTPUT VOLTAGE REGULATOR (8.3V OUTPUT)

The TA8214K is voltage regulator IC, designed for car audio use, has built-in 4 outputs. (Fixed 1 output and changed 3 outputs.)

The input-output differential voltage : V_{DIF} is very small. ($V_{DIF} = 0.3V$ (Typ.))

Because each outputs consist of PNP Transistor. In addition, protection of over voltage, output short and thermal shut down are involved.

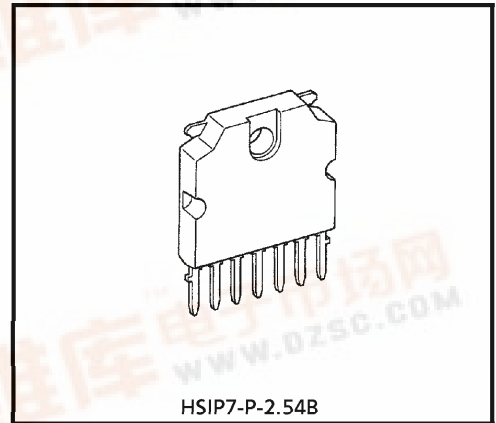

HSIP7-P-2.54B

Weight : 2.19g (Typ.)

FEATURES

- 4 Channel Outputs
 - OUT1 : 8.3V (Typ.) / 100mA (Max.) Fixed Output
 - OUT2 : 8.3V (Typ.) / 100mA (Max.)
 - OUT3 : 8.3V (Typ.) / 300mA (Max.)
 - OUT4 : 8.3V (Typ.) / 100mA (Max.)
- Very Small Input-Output Differential Voltage
 $V_{DIF} = 0.3V$ (Typ.)
- Built-in Various Protection Circuits
Over Voltage, Output Short, Thermal Shut Down
- Input Operating Voltage
 $V_{IN(opr)} = 9.3 \sim 18V$

BLOCK DIAGRAM

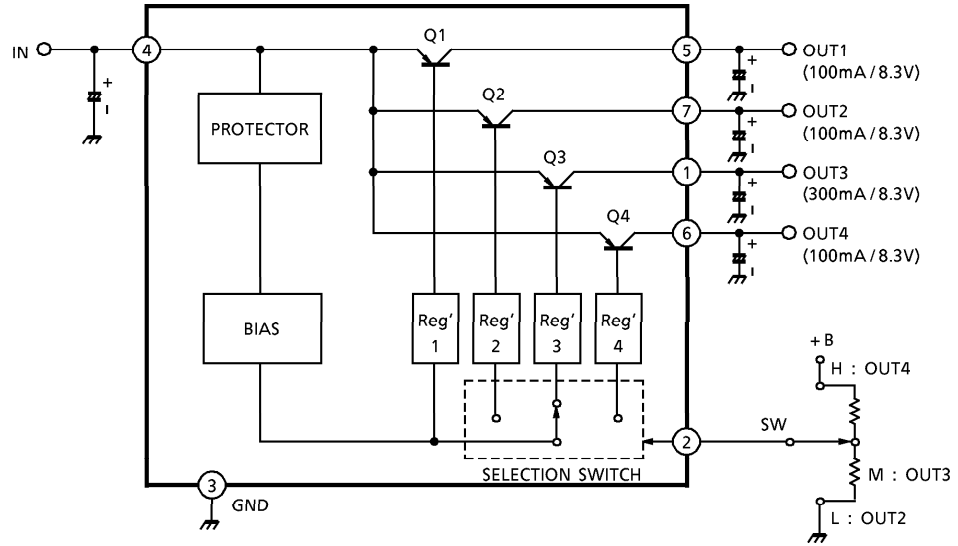

CAUTION FOR USE AND METHOD OF APPLICATION

(1) IC protective diode in $V_{IN} < V_{OUT}$ mode : D

When surge voltage is applied to the input/output terminals of IC or V_{OUT} becomes larger than V_{IN} ($V_{IN} < V_{OUT}$) at the time of power ON/OFF, insert a high speed switching diode : D.

(2) Power limiting register : R_{SD}

If V_{IN} is too high, insert a power limiting register : R_{SD} to reduce power dissipation of IC.

(3) Input surge protective Zener diode : ZD

Though an over voltage protective circuit (For positive surge) is built in, if excessive surge is input, insert a surge protective Zener diode : ZD.

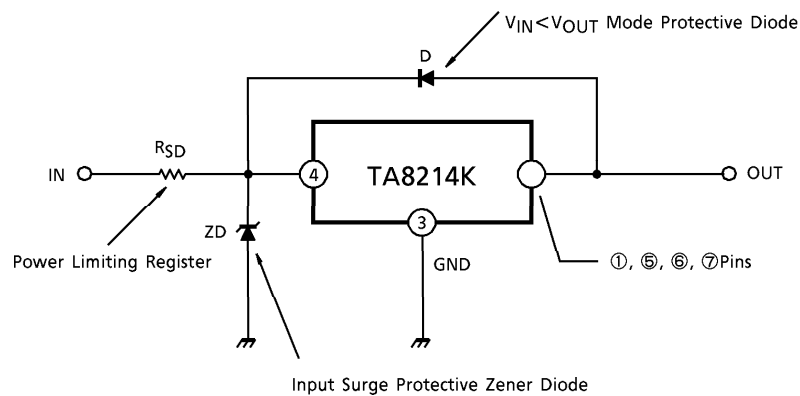

(Fig.1)

(4) Design of heat sink

Thermal resistance : θ_{j-T} of the package of this IC can be obtained from (Fig.2) according to the following expression :

$$\theta_{j-T} = \frac{150^{\circ}\text{C} - 75^{\circ}\text{C}}{15\text{W}} = 5^{\circ}\text{C} / \text{W}$$

(Terminal from the junction to the TAB) ... Expression ①

Thermal resistance : θ_{HS} of the heat sink attached to this IC is decided by the following expression :

$$\theta_{HS} = \frac{T_{j \text{ MAX}} - T_a}{P_{D \text{ MAX}}} - \theta_{j-T} \dots \text{Expression } \textcircled{2}$$

Where, $P_{D \text{ MAX}}$ expresses maximum power dissipation in this IC.

$$P_{D \text{ MAX}} = (V_{IN \text{ (MAX)}} - V_{OUT \text{ (MIN)}}) \times (I_1 + I_6 + I_7 + I_5 + I_B \text{ (MAX)}) \dots \text{Expression } \textcircled{3}$$

For instance, if this IC is used under the conditions of $V_{IN \text{ (MAX)}} = 16V$, $I_1 = 300mA$, $I_5 = 100mA$ and $T_a = \text{up to } 85^\circ C$ from Expression $\textcircled{3}$,

$P_{D \text{ MAX}} = (16V - 8V) \times (300mA + 100mA + 35mA) = 3.48W$ Substituting $P_{D \text{ MAX}} = 3.48W$ into Expression $\textcircled{2}$, above, θ_{HS} is obtained as follows :

$$\theta_{HS} = \frac{150^\circ C - 85^\circ C}{3.48W} - 5^\circ C/W = 13.7^\circ C/W$$

Accordingly, a heat sink having $\theta_{HS} = 13.7^\circ C/W$ becomes necessary and referring to (Fig.3), it can be set to be an aluminum plate 2mm in thickness and about 270 cm^2 in area.

However, when a heat sink is actually mounted to IC, the contact resistance is generated on its contacting surface and heat generated on its contacting surface and heat conduction becomes worse.

Therefore, a heat sink shall be designed with a sufficient margin of heat sink given.

Further, the TAB shall be grounded or kept open when the IC is used.

(5) Output capacitor for preventing the oscillation.

Type and capacity of a capacitor to be used between the output and GND shall be decided after thoroughly examining print pattern, route of connection, at high/low temperature, etc.

In particular, if inductor component is connected to the output, it is necessary to make the capacity larger than the recommended value.

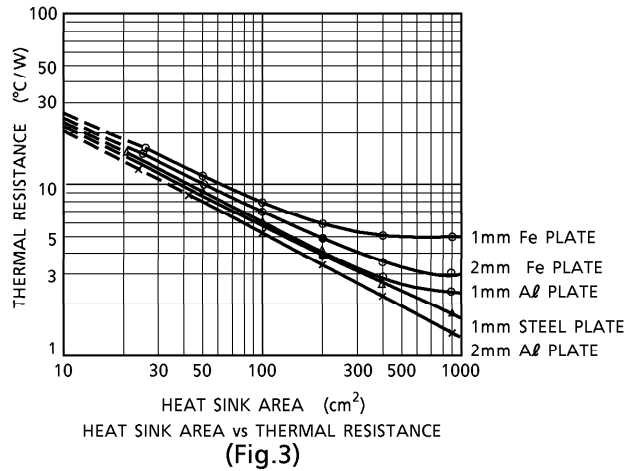
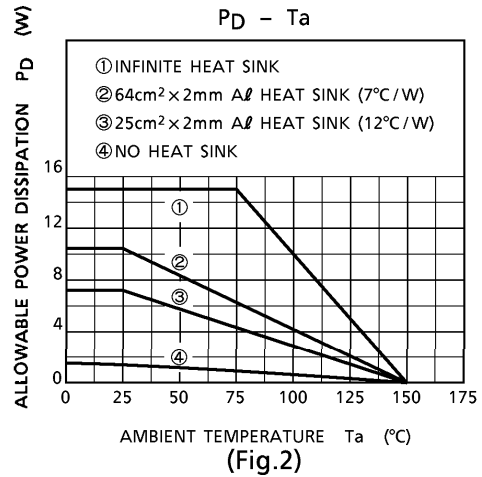

MAXIMUM RATINGS (Ta = 25°C)

CHARACTERISTIC	SYMBOL	RATING	UNIT
Peak Input Voltage (0.2s)	V _{IN(surge)}	50	V
DC Input Voltage	V _{IN(DC)}	25	V
Operating Input Voltage	V _{IN(opr)}	18	V
Power Dissipation	P _D	15	W
Operating Temperature	T _{opr}	-30~85	°C
Storage Temperature	T _{stg}	-55~150	°C

ELECTRICAL CHARACTERISTICS (Unless otherwise specified, V_{IN} = 13.2V, Ta = 25°C)

CHARACTERISTIC		SYMBOL	TEST CIRCUIT	TEST CONDITION	MIN.	TYP.	MAX.	UNIT	
Output Voltage	OUT1	V5	—	I5 = 100mA	8.0	8.3	8.6	V	
	OUT2	V7	—	I7 = 100mA	8.0	8.3	8.6		
	OUT3	V1	—	I1 = 300mA	8.0	8.3	8.6		
	OUT4	V6	—	I6 = 100mA	8.0	8.3	8.6		
Bias Current		I _B	—	I5, 7, 1, 6 = 0	—	12	35	mA	
Input Variation		ΔV _{O1}	—	V _{IN} = 9.3~18V I5, 7, 6 = 100mA, I1 = 300mA	—	—	± 50	mV	
Load Variation		ΔV _{O2}	—	I5, 7, 6 = 0~100mA I1 = 0~300mA	—	—	± 50	mV	
Input-Output Voltage Difference		V _{DIF}	—	I5, 7, 6 = 100mA, I1 = 300mA	—	0.3	0.6	V	
Ripple Rejection Ratio		R.R.	—	f = 100Hz, V _{ripple} = 0.775V _{rms} (0dBm) I5, 7, 6 = 100mA, I1 = 300mA	50	65	—	dB	
Max. Output Current	OUT 1, 2, 4	I _{MAX 5, 7, 6}	—	—	100	—	—	mA	
	OUT3	I _{MAX 1}	—	—	300	—	—		
Output Voltage Temperature Coefficient		TC _{VO}	—	I5, 7, 6 = 100mA, I1 = 300mA	—	+1	—	mV/deg	
Control Terminal Input Resistance		R _{CONT}	—	—	6	10	—	kΩ	
Control Voltage	V _H	—	—	V6 (OUT4) : ON	Ta = -30 ~80°C	7.0	—	V _{IN}	V
	V _M	—	—	V1 (OUT3) : ON		2.8	—	5.5	
	V _L	—	—	V7 (OUT2) : ON		0	—	1.2	

TEST CIRCUIT

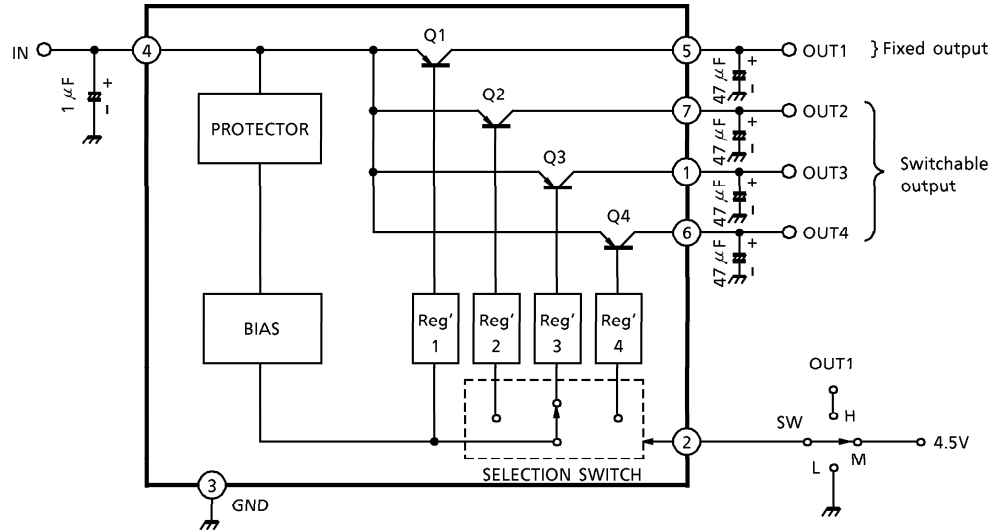

- (Note 1) Heat sink must be used with its fin grounded or in "open" status.
- (Note 2) When inductor element is connected to output, increase the capacity value of oscillation stop capacitor between output and GND.

V5, V6, V7 - V_{IN}

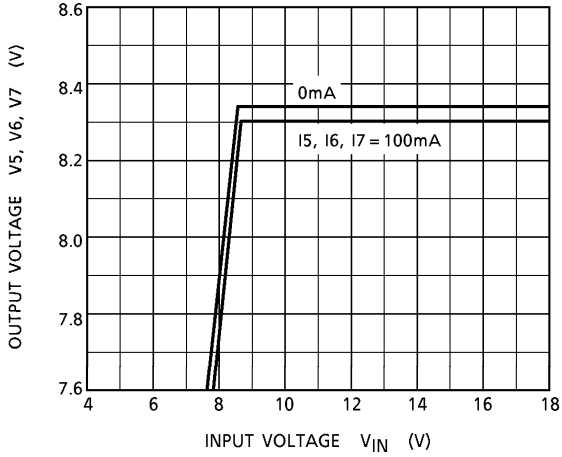

V1 - V_{IN}

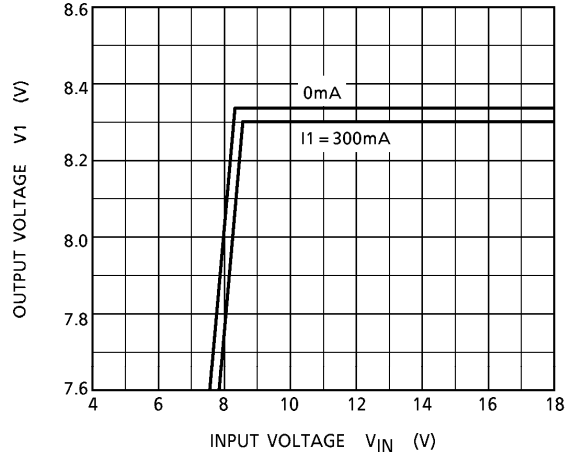

V5, V6, V7 - I5, I6, I7

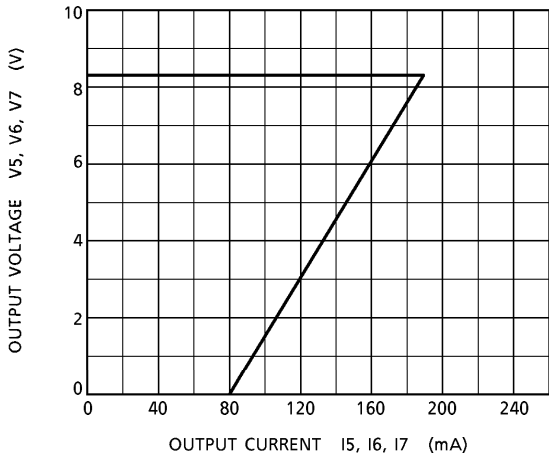

V1 - I1

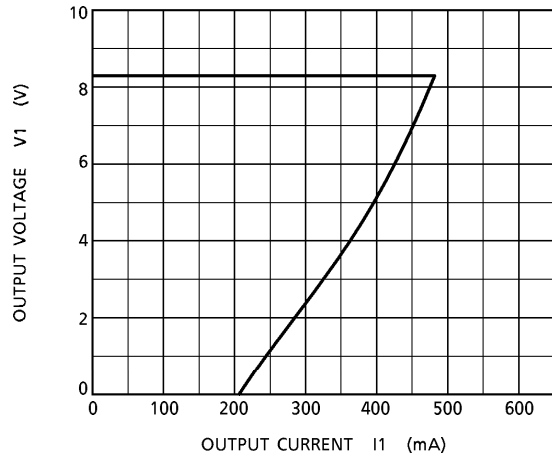

V1, V5, V6, V7 - V_{DIF}

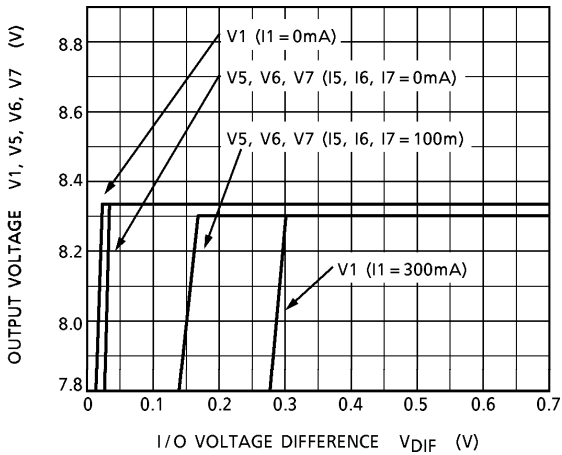

P_D - T_a

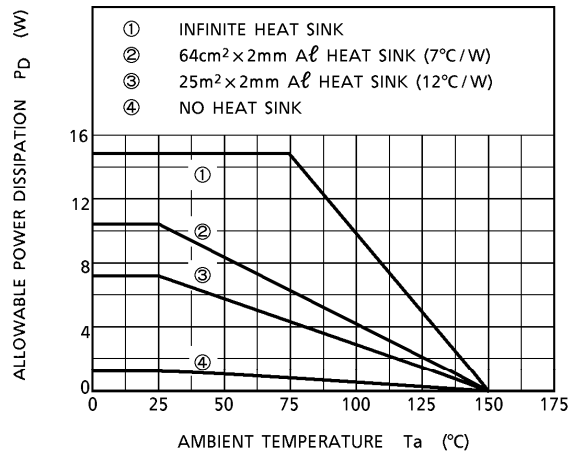

$V_H, V_M, V_L - T_a$

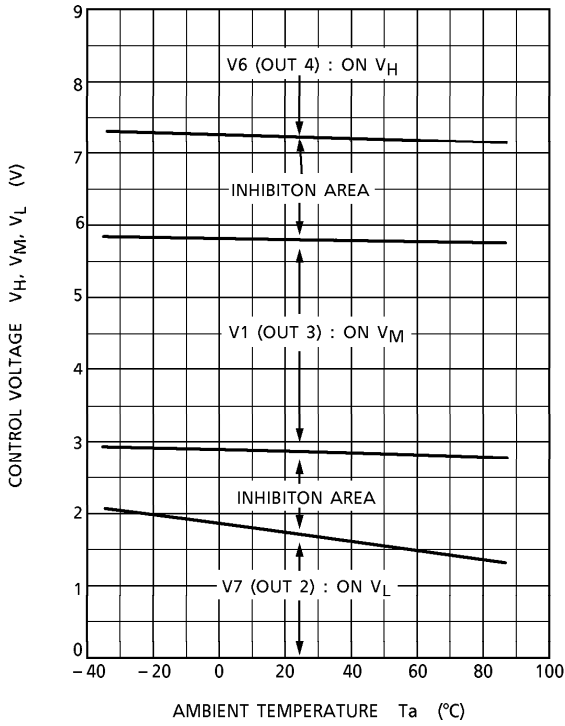

R. R. - f

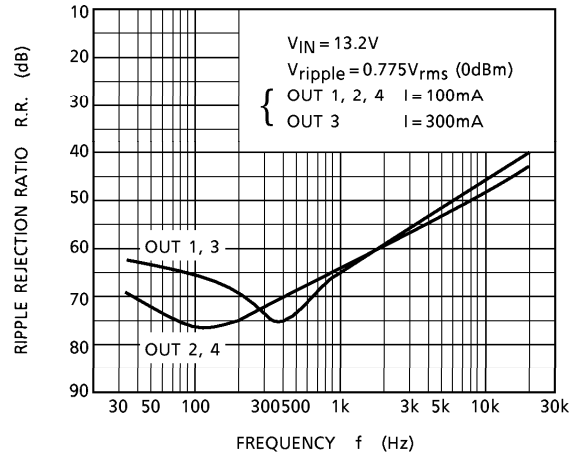

APPLICATION CIRCUIT

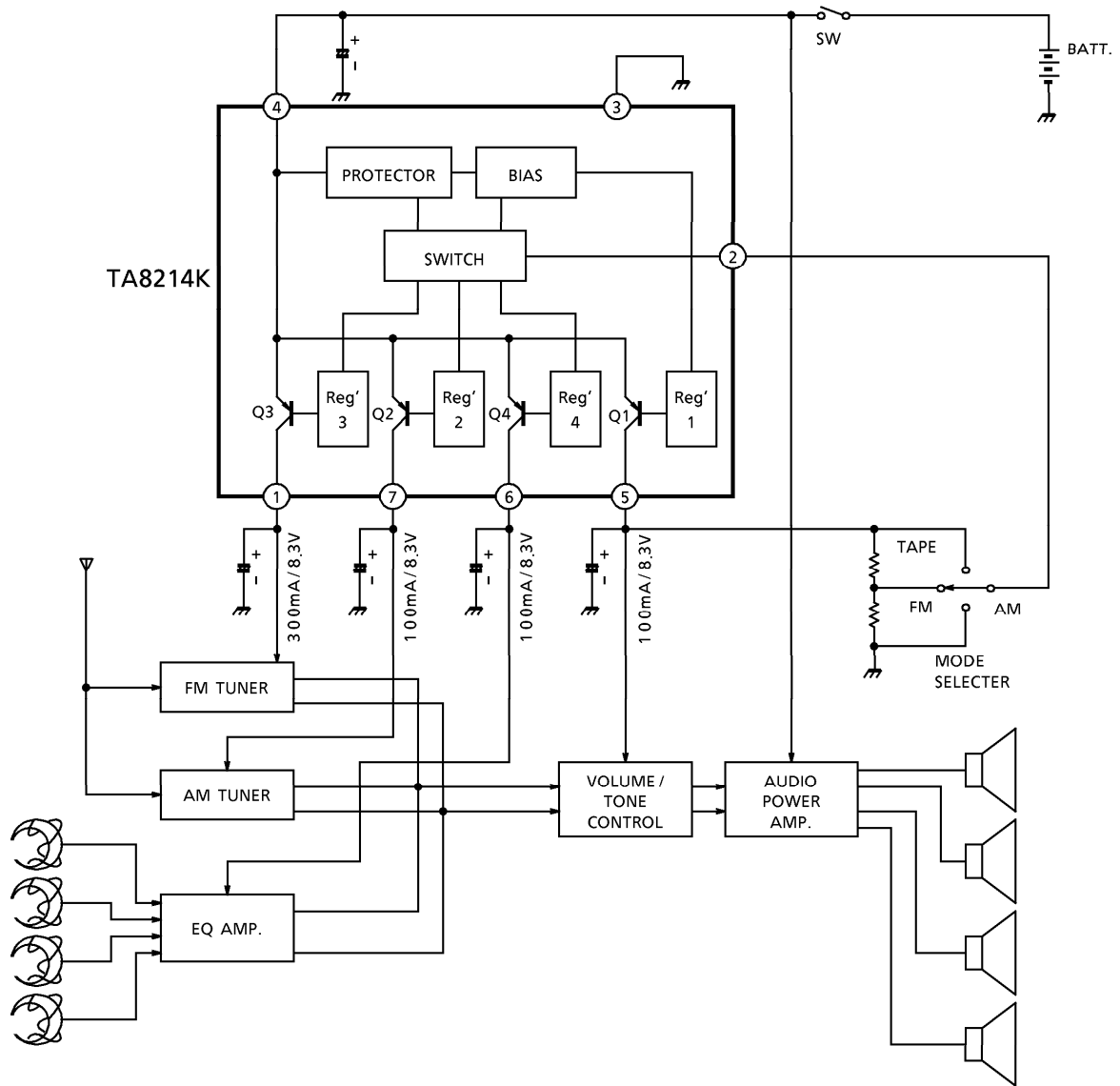

PACKAGE DIMENSIONS
HSIP7-P-2.54B

Unit : mm

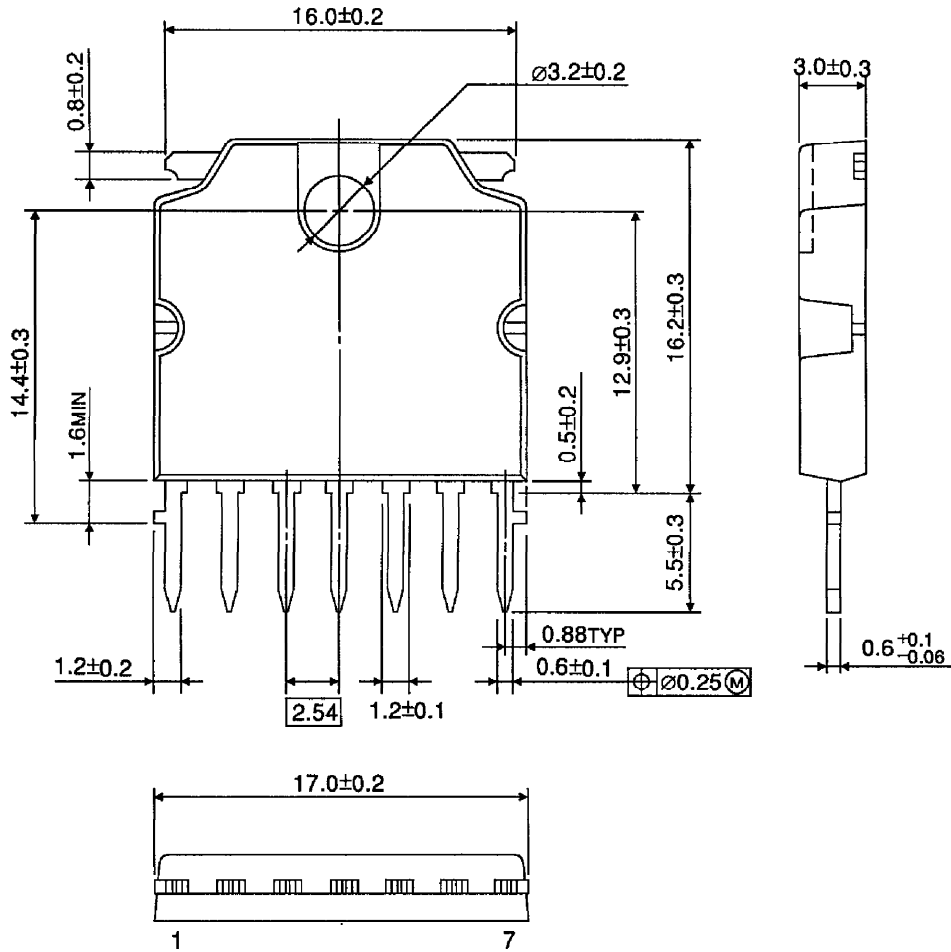

Weight : 2.19g (Typ.)

RESTRICTIONS ON PRODUCT USE

000707EBF

- TOSHIBA is continually working to improve the quality and reliability of its products. Nevertheless, semiconductor devices in general can malfunction or fail due to their inherent electrical sensitivity and vulnerability to physical stress. It is the responsibility of the buyer, when utilizing TOSHIBA products, to comply with the standards of safety in making a safe design for the entire system, and to avoid situations in which a malfunction or failure of such TOSHIBA products could cause loss of human life, bodily injury or damage to property. In developing your designs, please ensure that TOSHIBA products are used within specified operating ranges as set forth in the most recent TOSHIBA products specifications. Also, please keep in mind the precautions and conditions set forth in the "Handling Guide for Semiconductor Devices," or "TOSHIBA Semiconductor Reliability Handbook" etc..
- The TOSHIBA products listed in this document are intended for usage in general electronics applications (computer, personal equipment, office equipment, measuring equipment, industrial robotics, domestic appliances, etc.). These TOSHIBA products are neither intended nor warranted for usage in equipment that requires extraordinarily high quality and/or reliability or a malfunction or failure of which may cause loss of human life or bodily injury ("Unintended Usage"). Unintended Usage include atomic energy control instruments, airplane or spaceship instruments, transportation instruments, traffic signal instruments, combustion control instruments, medical instruments, all types of safety devices, etc.. Unintended Usage of TOSHIBA products listed in this document shall be made at the customer's own risk.
- This product generates heat during normal operation. However, substandard performance or malfunction may cause the product and its peripherals to reach abnormally high temperatures. The product is often the final stage (the external output stage) of a circuit. Substandard performance or malfunction of the destination device to which the circuit supplies output may cause damage to the circuit or to the product.
- The products described in this document are subject to the foreign exchange and foreign trade laws.
- The information contained herein is presented only as a guide for the applications of our products. No responsibility is assumed by TOSHIBA CORPORATION for any infringements of intellectual property or other rights of the third parties which may result from its use. No license is granted by implication or otherwise under any intellectual property or other rights of TOSHIBA CORPORATION or others.
- The information contained herein is subject to change without notice.