

**TOSHIBA**

**TA8331AN**

TENTATIVE TOSHIBA BIPOLAR LINEAR INTEGRATED CIRCUIT SILICON MONOLITHIC

# TA8331AN

## IH APPLIANCE CONTROLLER

TA8331AN is a control IC on a single chip dedicated to the control of the switching power supply, inverter, IGBT driver, and protector circuits in induction rice cookers and induction cookers.

The device is intended to reduce both the number of external components and the board size.

### FEATURES

- Incorporates a switching power supply control circuit as a power supply for the IGBT driver block or DC fan motor or similar.
- Incorporates an under-voltage lockout (UVLO) function. (Startup voltage : 4.8V, shutdown voltage : 4.2V)
- Incorporates an inverter control circuit for the IGBT driver, thus enabling the number of external components to be reduced.
- Can directly drive the IGBT gate using a high current. (Source current : -200mA (max), sink current 1A (max))
- Incorporates a diode to protect the IGBT gate at power on.
- Incorporates a comparator to detect low voltage, such as at an outage.
- Incorporates various comparators for over-voltage detection.
- Incorporates a function to detect over-voltages such as surges and to stop the IGBT drive signal.

(Note) Since this product has a low electrostatic breakdown voltage, take great care when handling.

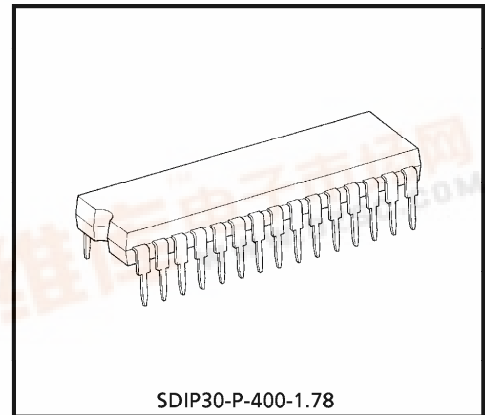

SDIP30-P-400-1.78

Weight : 1.99g (Typ.)

961001EBA1

- TOSHIBA is continually working to improve the quality and the reliability of its products. Nevertheless, semiconductor devices in general can malfunction or fail due to their inherent electrical sensitivity and vulnerability to physical stress. It is the responsibility of the buyer, when utilizing TOSHIBA products, to observe standards of safety, and to avoid situations in which a malfunction or failure of a TOSHIBA product could cause loss of human life, bodily injury or damage to property. In developing your designs, please ensure that TOSHIBA products are used within specified operating ranges as set forth in the most recent products specifications. Also, please keep in mind the precautions and conditions set forth in the TOSHIBA Semiconductor Reliability Handbook.
- The products described in this document are subject to foreign exchange and foreign trade control laws.
- The information contained herein is presented only as a guide for the applications of our products. No responsibility is assumed by TOSHIBA CORPORATION for any infringements of intellectual property or other rights of the third parties which may result from its use. No license is granted by implication or otherwise under any intellectual property or other rights of TOSHIBA CORPORATION or others.
- The information contained herein is subject to change without notice.



BLOCK DIAGRAM

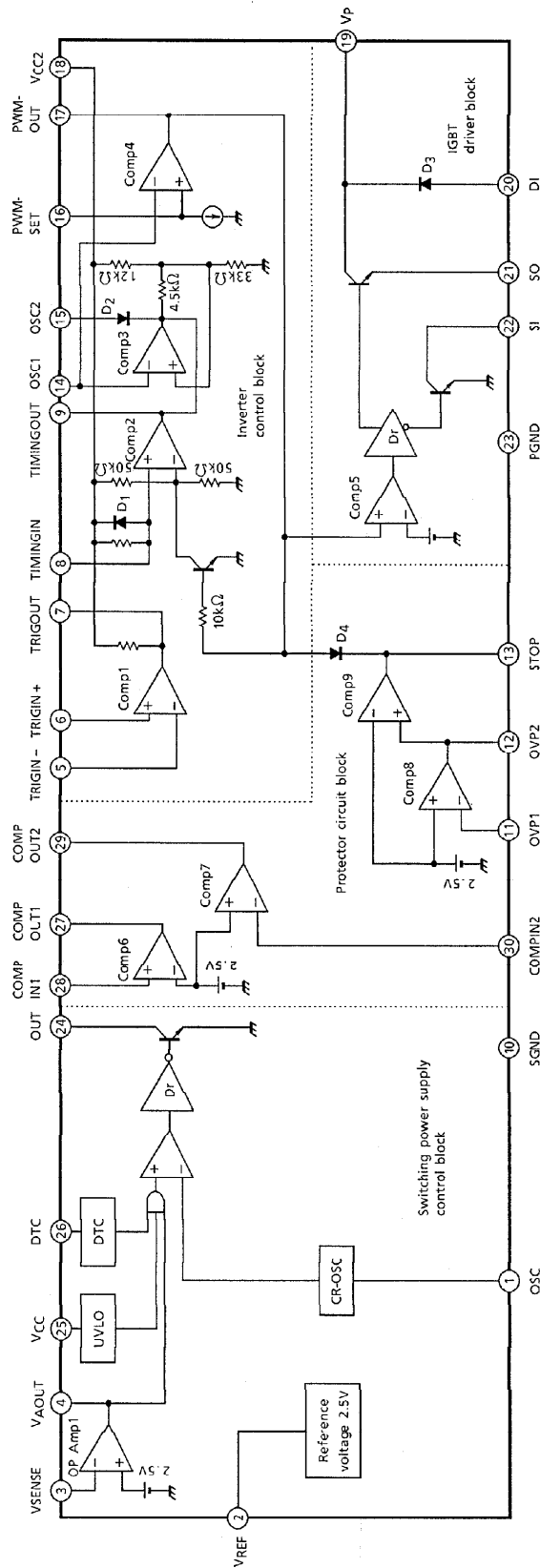

**PIN CONNECTION**

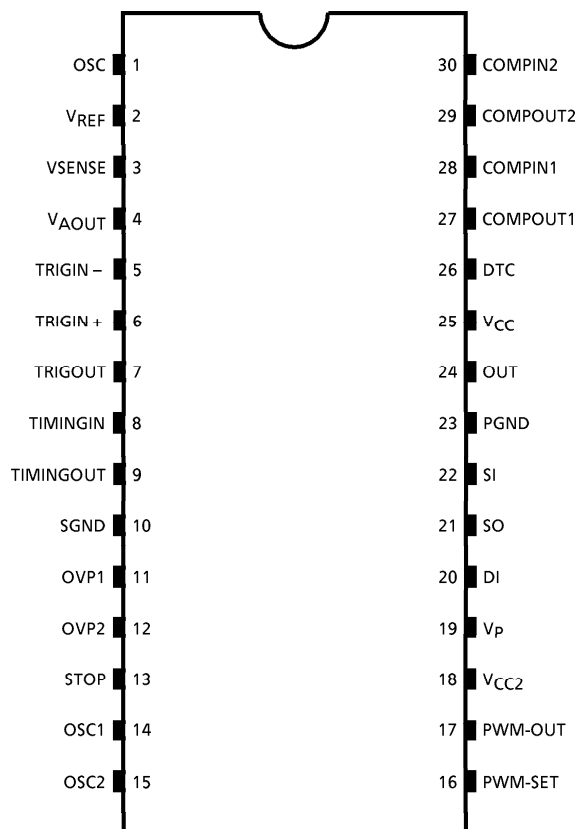

## PIN FUNCTIONS

PIN No.	PIN NAME	FUNCTION
1	OSC	Oscillator connecting pin for switching power supply
2	V <sub>REF</sub>	Reference voltage output pin
3	V <sub>SENSE</sub>	Input pin for output voltage detection
4	V <sub>AOUT</sub>	Voltage error amp output pin
5	TRIGIN -	Trigger signal input pin 1 (- side)
6	TRIGIN +	Trigger signal input pin 2 (+ side)
7	TRIGOUT	Trigger signal output pin
8	TIMINGIN	Oscillation timing signal input pin
9	TIMINGOUT	Oscillation timing signal output pin
10	SGND	Signal GND
11	OVP1	Over-voltage detect input pin 1
12	OVP2	Over-voltage detect input pin 2
13	STOP	PWM stop signal output pin
14	OSC1	PWM oscillator connecting pin 1
15	OSC2	PWM oscillator connecting pin 2
16	PWM-SET	PWM output adjustment input pin
17	PWM-OUT	PWM signal output pin (open collector output)
18	V <sub>CC2</sub>	System power supply 2 (inverter control block/protector circuit block)
19	V <sub>p</sub>	Power supply for power (IGBT driver block)
20	DI	IGBT gate protector diode pin
21	SO	IGBT gate drive pin 1 (source side)
22	SI	IGBT gate drive pin 2 (sink side)
23	PGND	Power GND
24	OUT	Switching power supply control output pin (open collector output)
25	V <sub>CC</sub>	System power supply (switching power supply block)
26	DTC	Dead time control pin
27	COMPOUT1	Comparator output pin 1 (for low voltage detection) (open collector output)
28	COMPIN1	Comparator input pin 1 (for low voltage detection)
29	COMPOUT2	Comparator output pin 2 (for over-voltage detection) (open collector output)
30	COMPIN2	Comparator input pin 2 (for over-voltage detection)

**FUNCTIONS**

1. Switching power supply control circuit

Incorporates a step-down switching power supply control function for the IGBT driver block power supply ( $V_p$ ) or DC fan motor power supply.

When  $DC_{out} = H$  ( $VSENSE = H$ ) : Output driver = ON (switching power supply = OFF)

When  $DC_{out} = L$  ( $VSENSE = L$ ) : Output driver = OFF (switching power supply = ON)

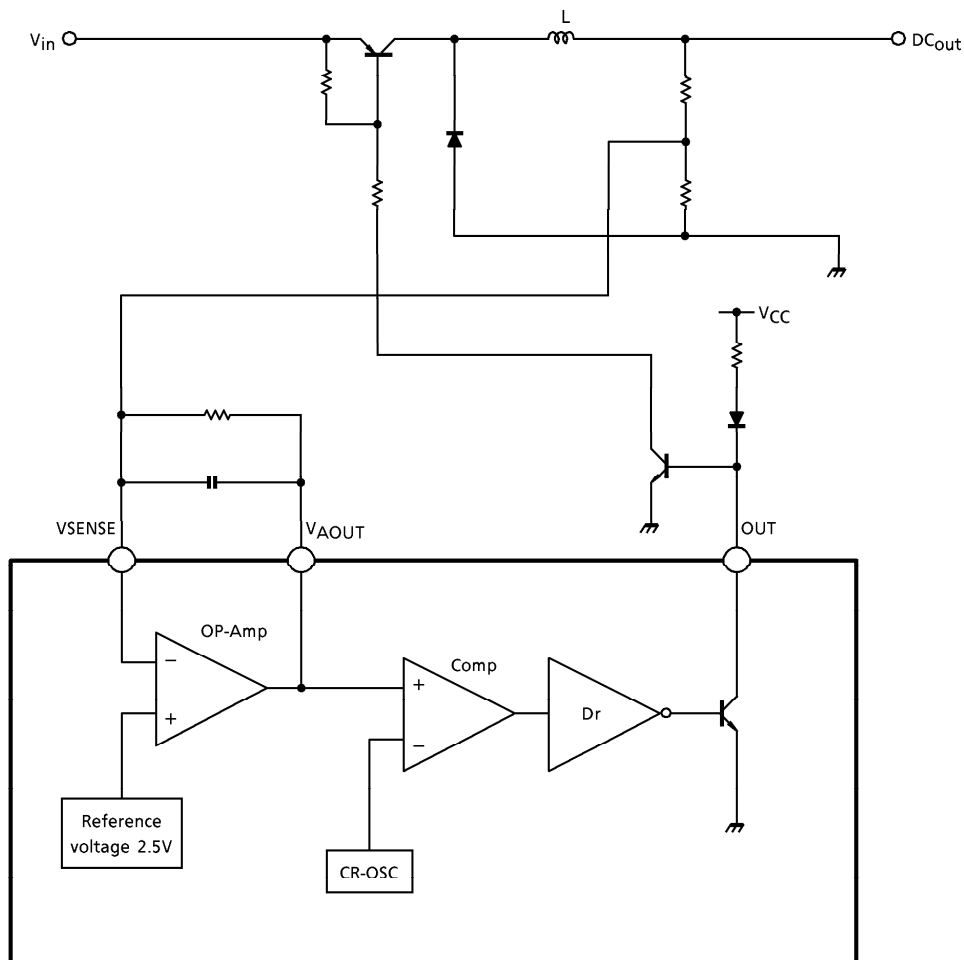

2. UVLO (Under-Voltage Lock out) function

To prevent malfunction, a function is incorporated to shut down the switching power supply control block when the power supply voltage ( $V_{CC}$ ) drops.

This function detects power supply voltage  $V_{CC}$  in the IC. If voltage is 4.8V or higher, the switching driver can operate. If voltage is 4.2V or lower, the switching driver is shut down.

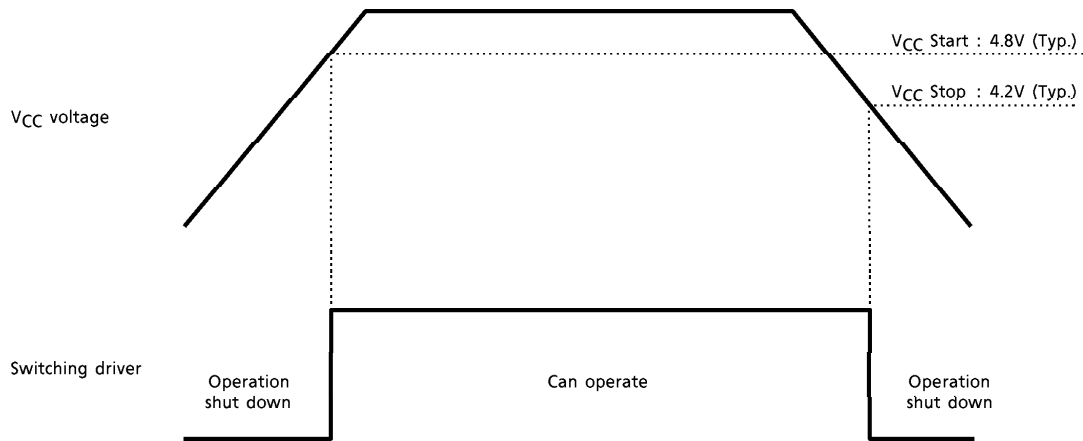

3. Dead time control function

Dead time control (DTC) is used to set the output pulse of the switching power supply control block to maximum duty.

Depending on the DTC pin voltage, a maximum duty of up to 100% can be set.

DTC pin voltage low  $\rightarrow$   $V_{OUT}$  high  $\rightarrow$  output driver duty large

DTC pin voltage high  $\rightarrow$   $V_{OUT}$  low  $\rightarrow$  output driver duty small

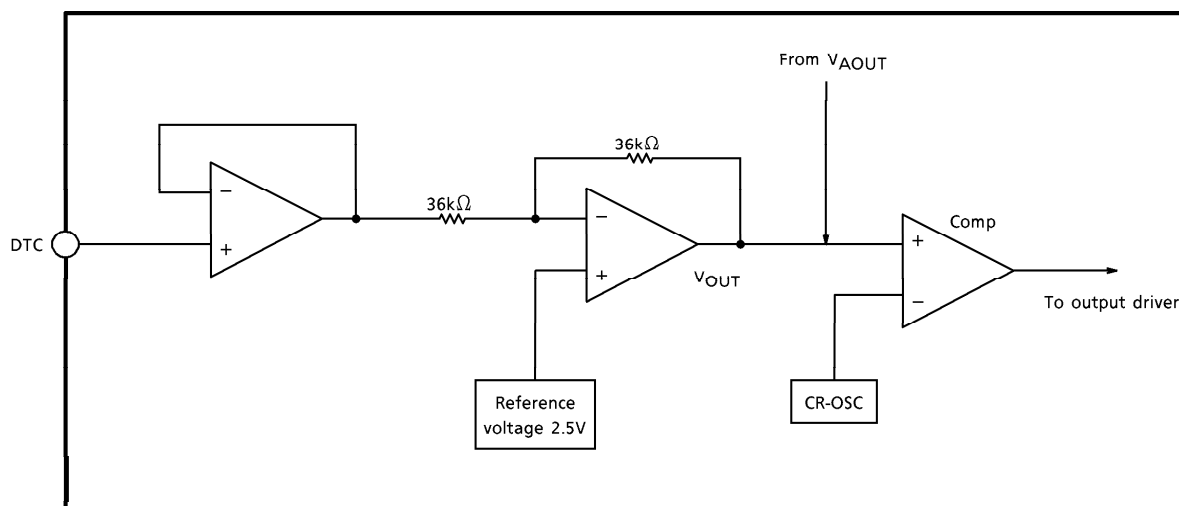

\* Output on duty characteristics (reference)

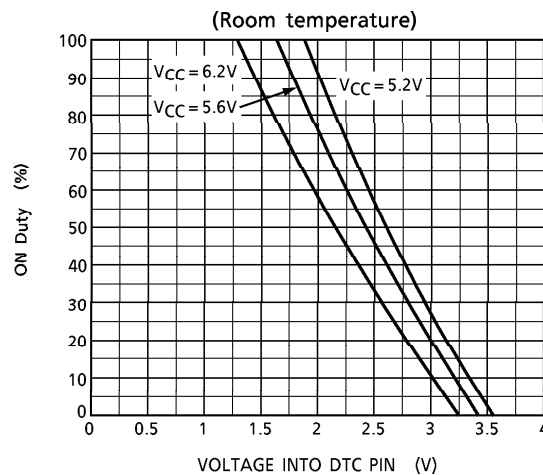

4. CR oscillator circuit

The oscillator for the switching power supply control is connected to an external capacitor and a resistor. This oscillator is used to set the switching frequency.

$V_{Hosc}$  and  $V_{Losc}$  are obtained by dividing the  $V_{CC}$  using the resistance within the IC.

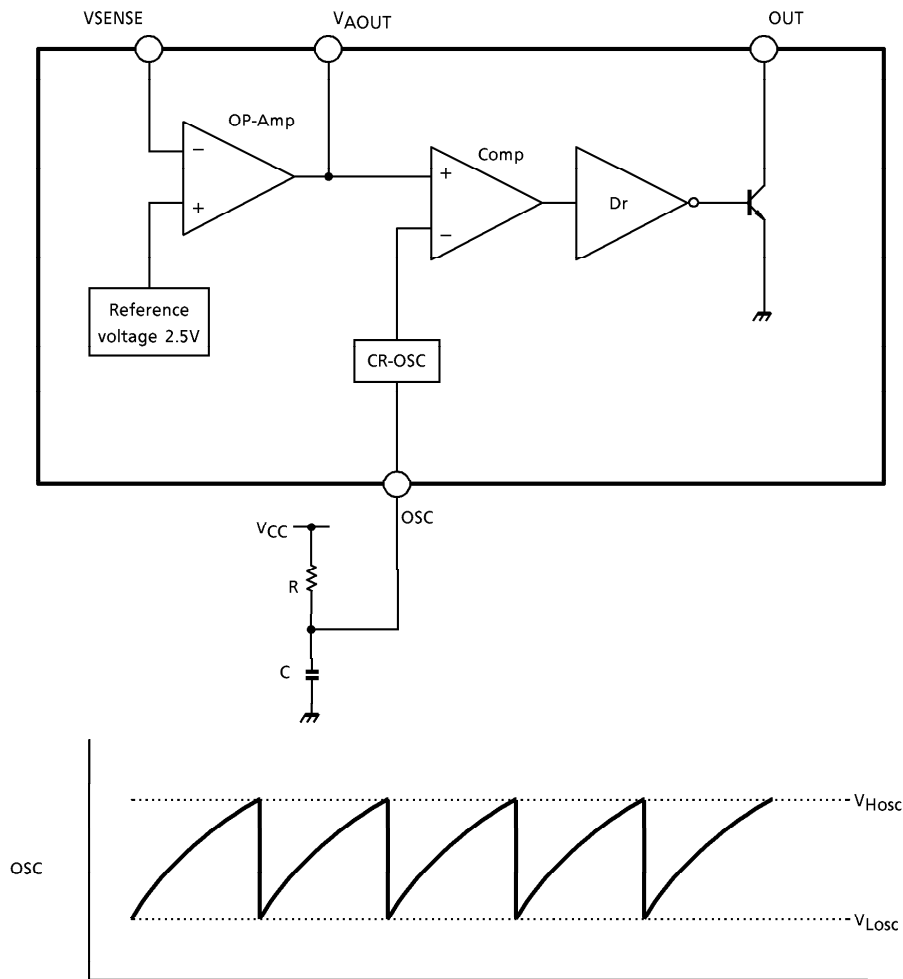

$V_{Hosc}$  and  $V_{Losc}$  are set within the IC as shown in the diagram.

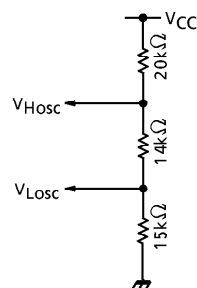



For the oscillation frequency setting, see the following graph.

\* Oscillation frequency characteristics of switching power supply block (reference)

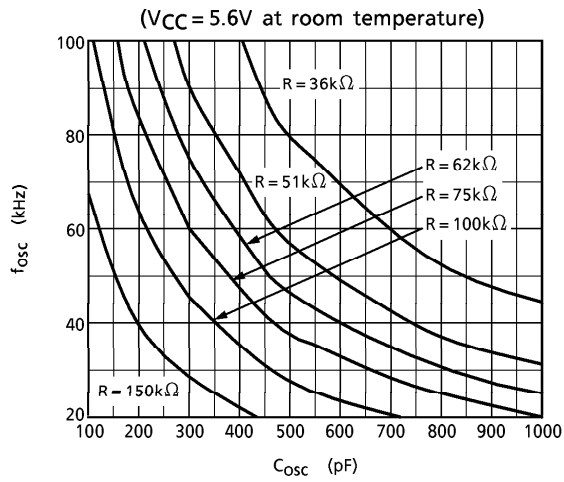

5. Oscillation timing circuit (trigger comparator/timing comparator)

The trigger comparator detects the oscillation timing ; the timing comparator generates the timing signal.

This timing signal is passed on to the next stage oscillator circuit.

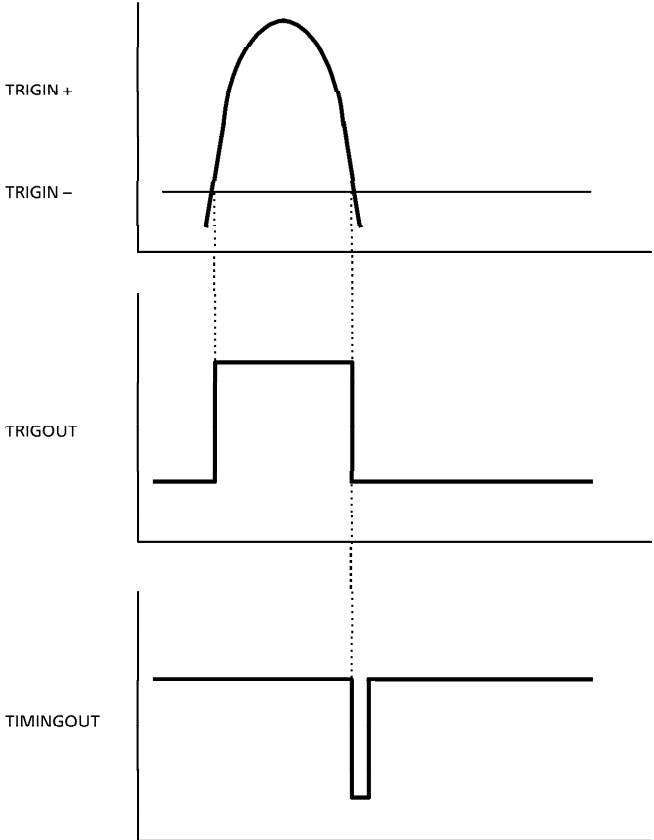
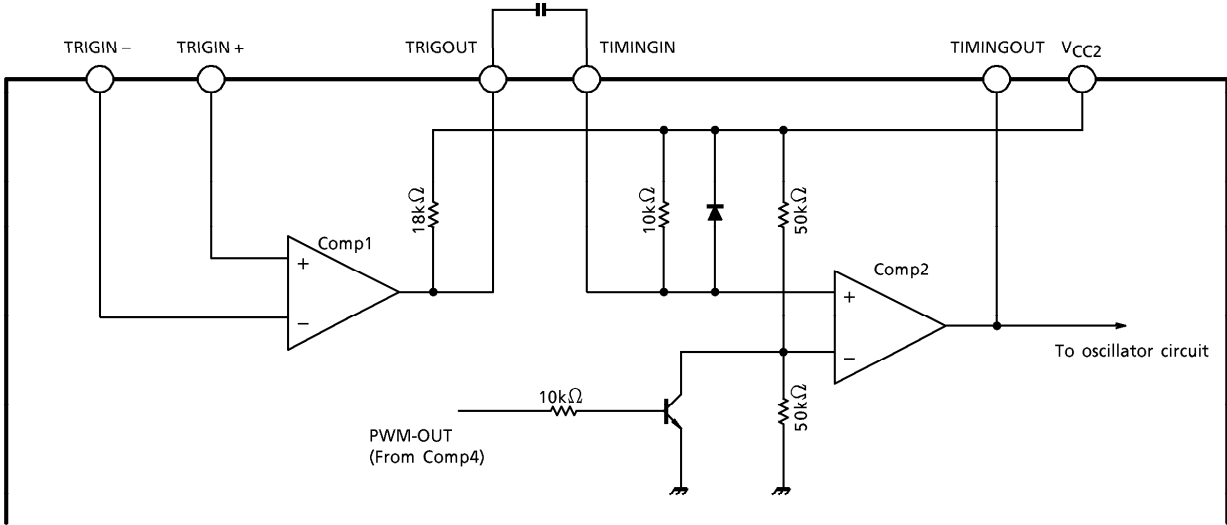

6. Oscillator circuit 1 (Oscillation comparator)

This circuit generates a saw-tooth wave signal for the IGBT driver that starts on a timing signal from the oscillation timing circuit.

R<sub>1</sub>, R<sub>2</sub> and R<sub>3</sub> in the IC are used to set the oscillation amplitude of this saw-tooth wave signal.

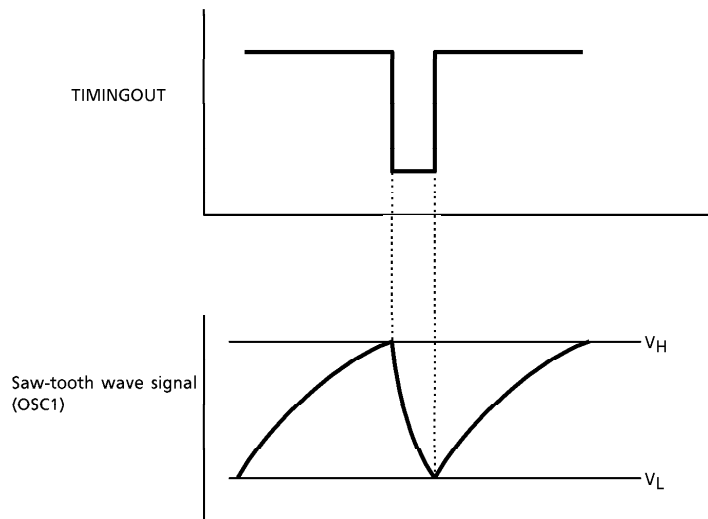
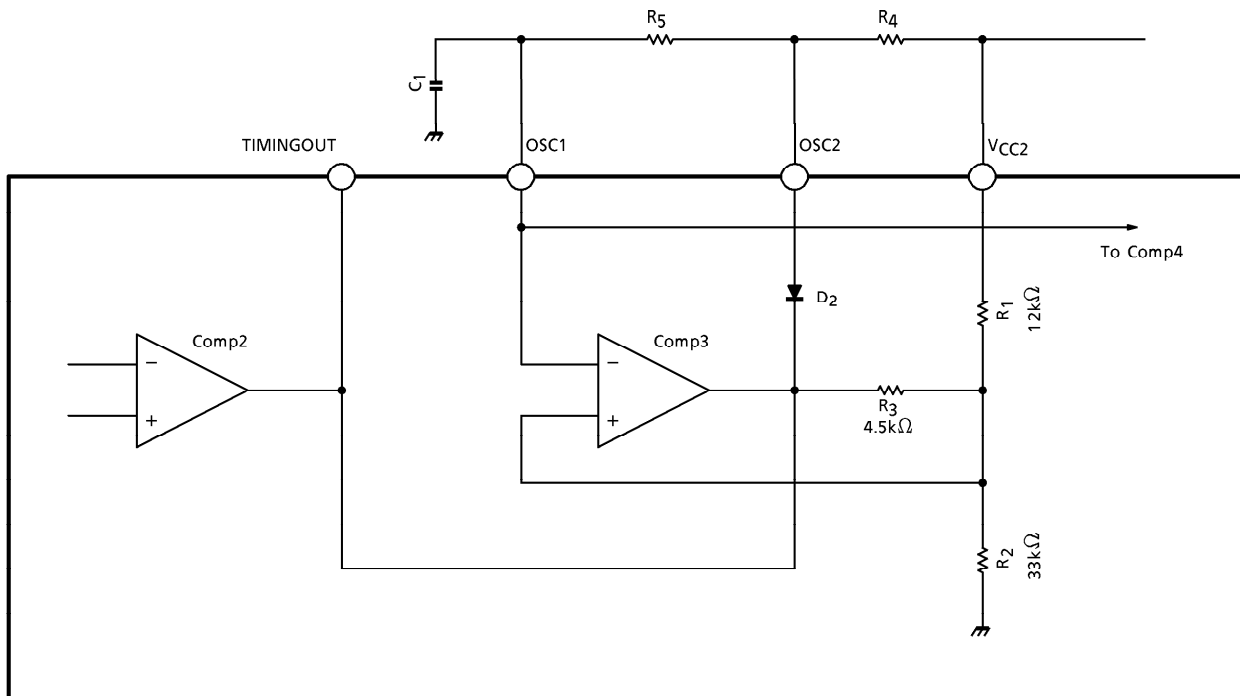

Here, V<sub>H</sub> and V<sub>L</sub> are as follows :

$$V_H = \frac{R_1}{R_1 + R_2} \times V_{CC2} \text{ (V)}$$

$$V_L = \frac{R_3}{R_1 + R_3} \times (V_{CC2} - V_{OL}) + V_{OL} \text{ (V)}$$

7. Oscillator circuit 2 (PWM comparator)

The width of the pulse for the IGBT driver is set by the saw-tooth wave signal from the oscillation comparator and the external output adjustment level.

Input to the PWM-SET pin the PWM output adjustment level from a source such as the microcontroller.

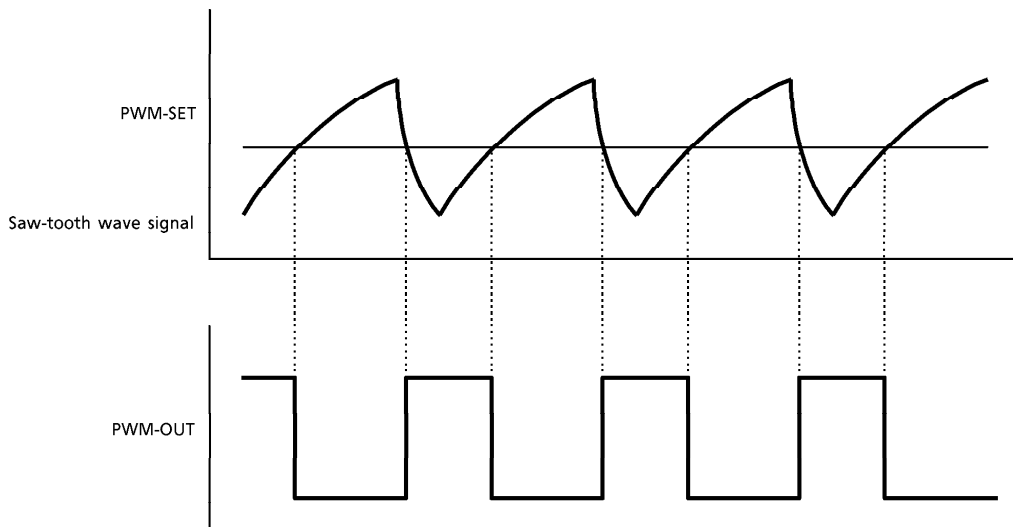
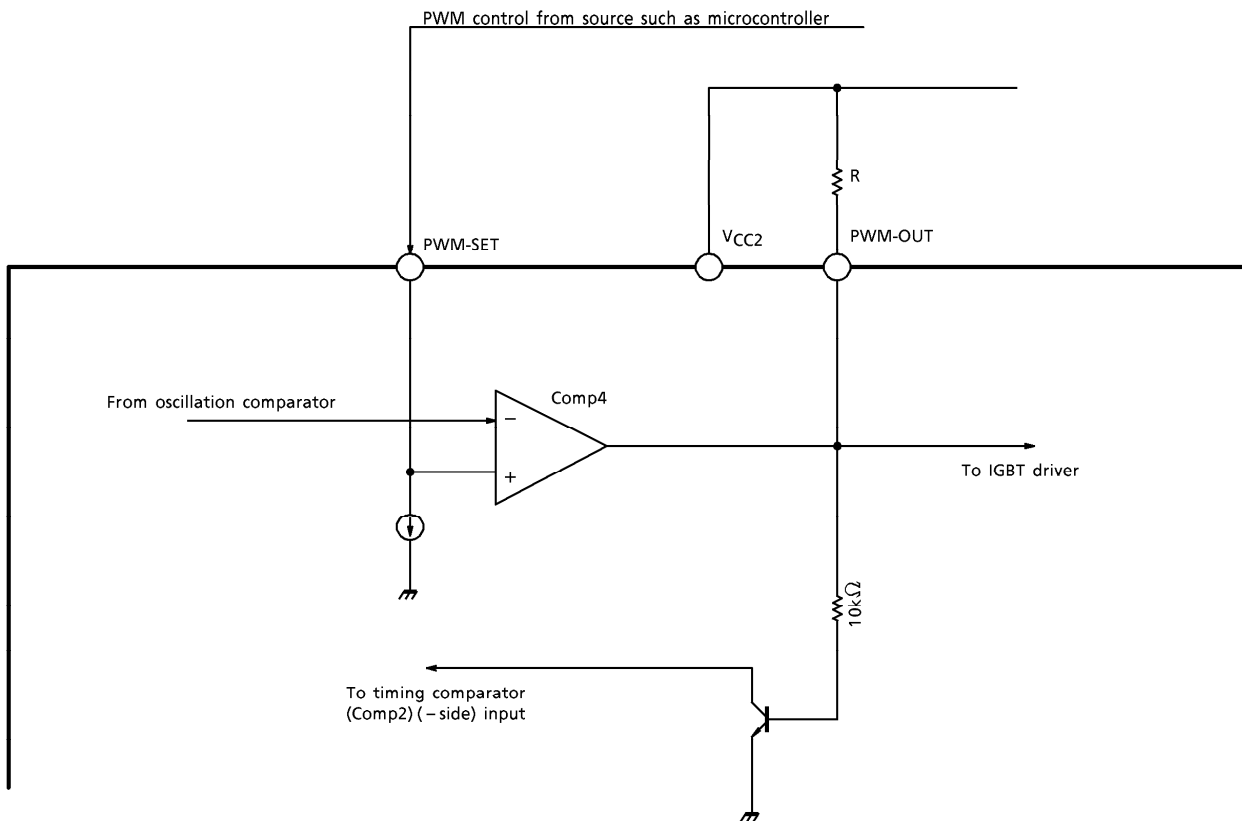

8. IGBT driver

The IGBT driver can be directly driven by a PWM signal from the PWM control block.

Source current : -200mA (max)

Sink current : 1A (max)

In addition, the device incorporates an IGBT gate protector diode to prevent malfunction at power on.

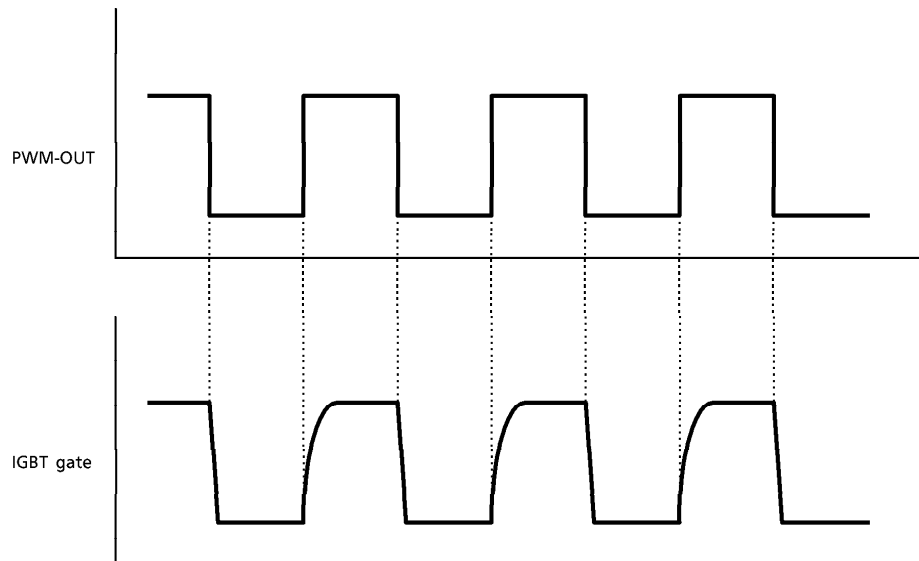
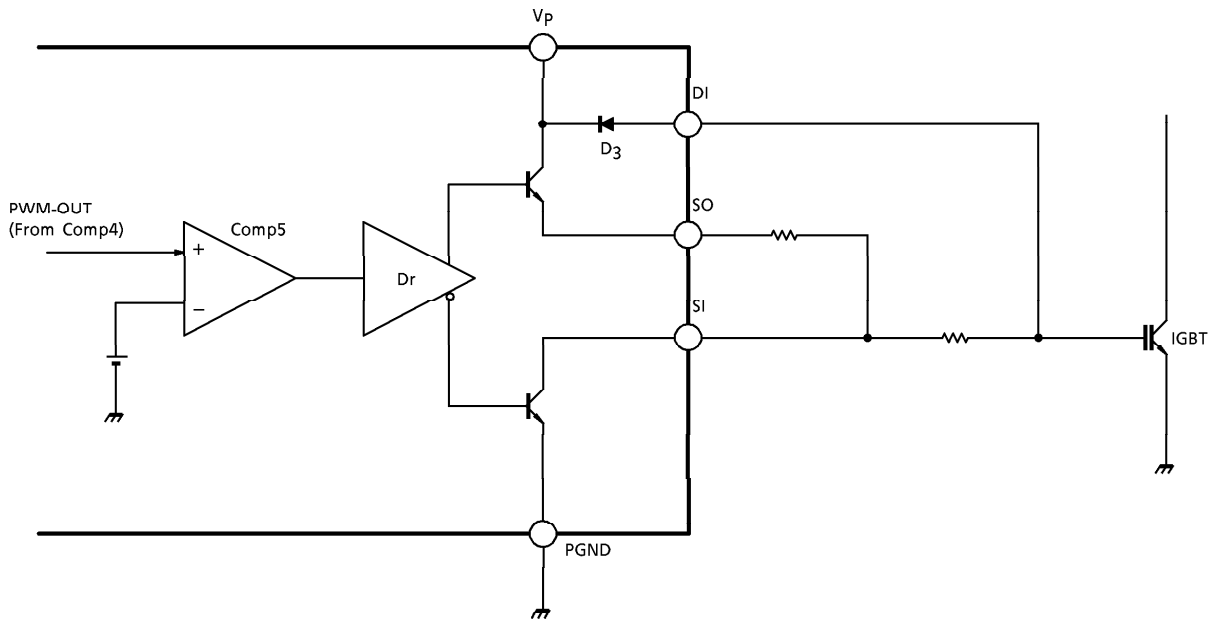

\* Reference data

Load capacitance – Output rise / fall time characteristics  
 ( $V_{CC} = 5.6V$ ,  $V_{CC2} = 12V$ ,  $V_p = 20V$ , at room temperature)

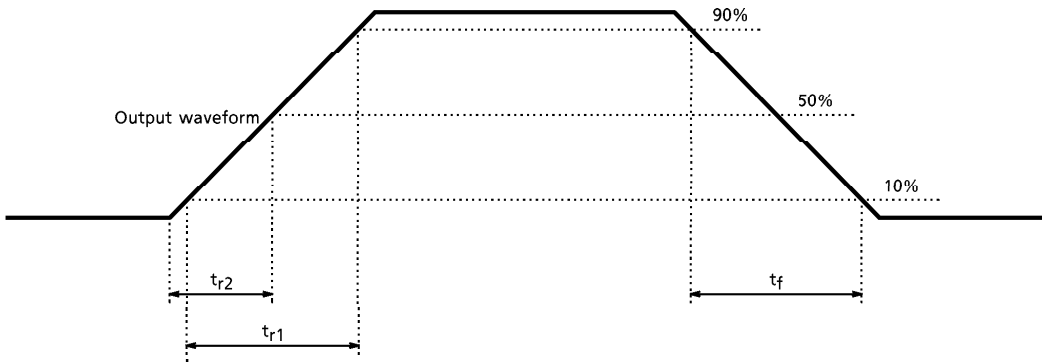

① Load capacitance – Output rise time characteristics 1

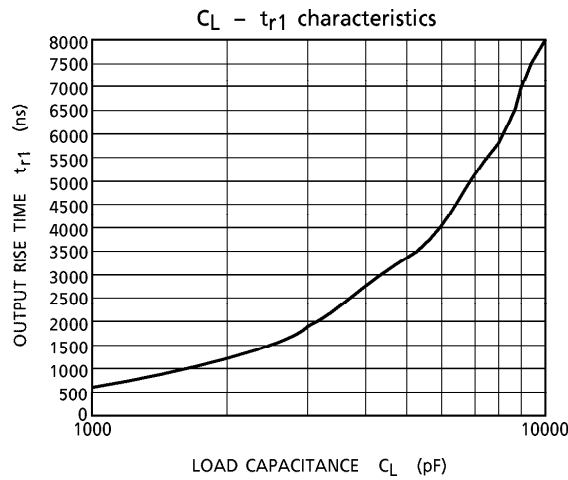

② Load capacitance – Output rise time characteristics 2

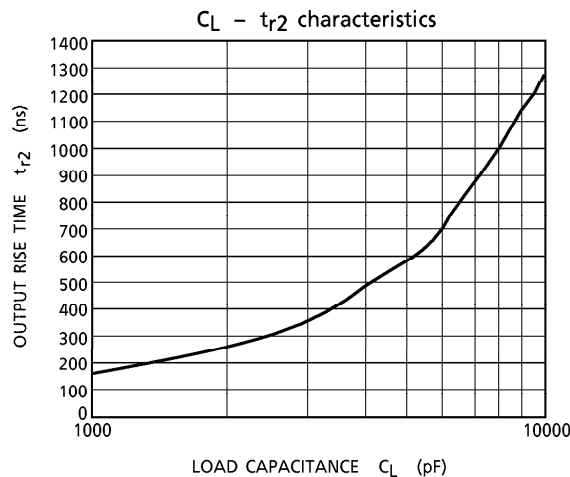

③ Load capacitance – Output fall time characteristics

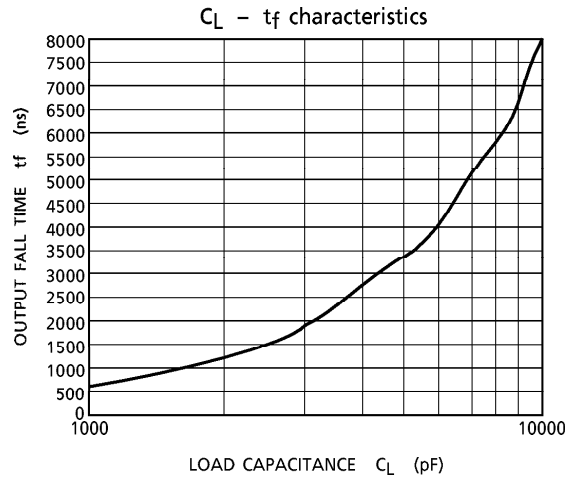

9. Low voltage detection function

The device incorporates a comparator to detect a fall in voltage, for example at an outage, and output a detection signal to an external device such as a microcontroller.

Monitoring of switching power supply output voltage

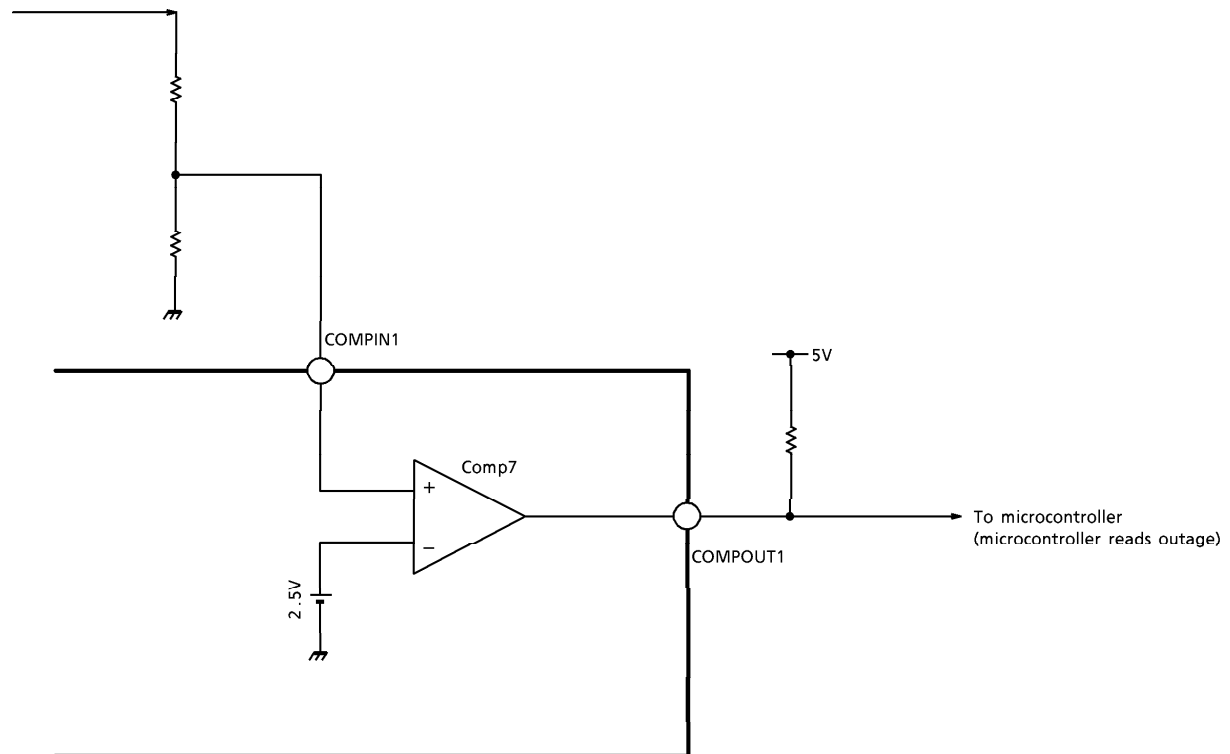

10. Over-voltage detection function 1

The device incorporates a comparator to detect over-voltage and output a detection signal to an external device such as a microcontroller.

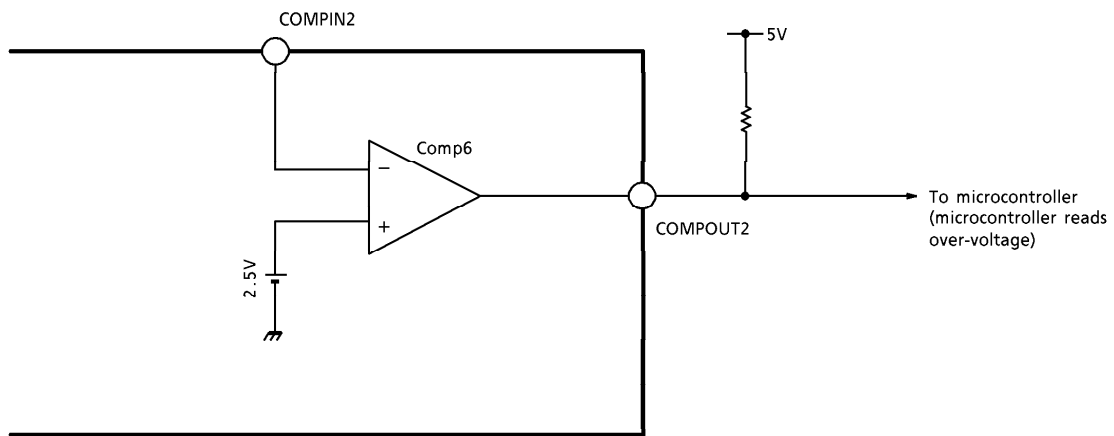



11. Over-voltage detection function 2

The device incorporates a function to detect over-voltages such as surges and to stop the PWM signal that drives the IGBT.

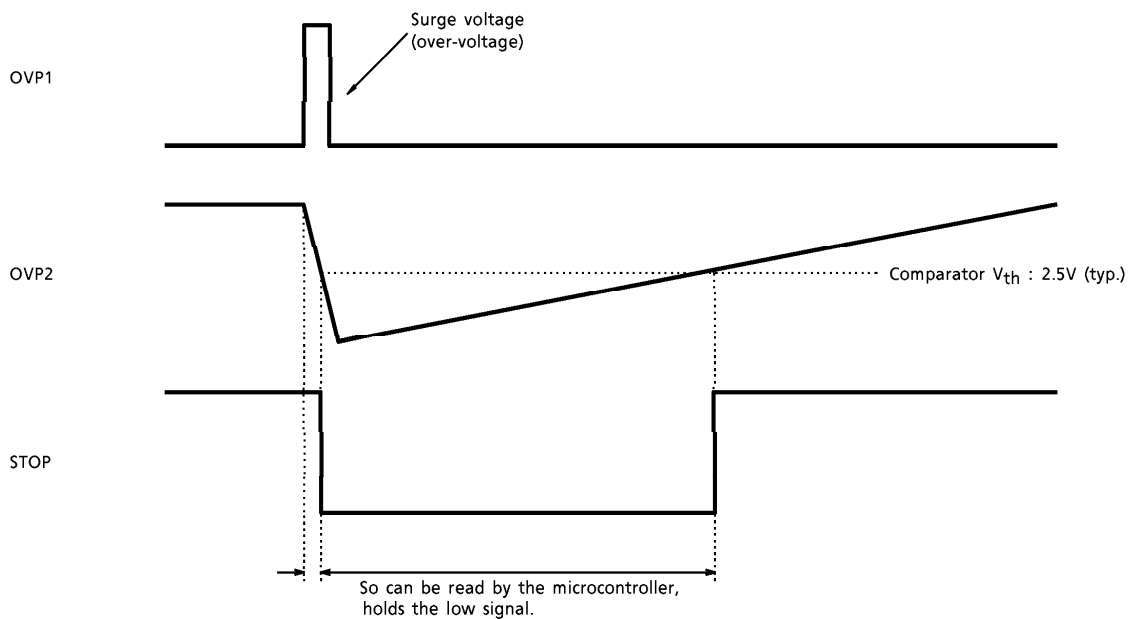
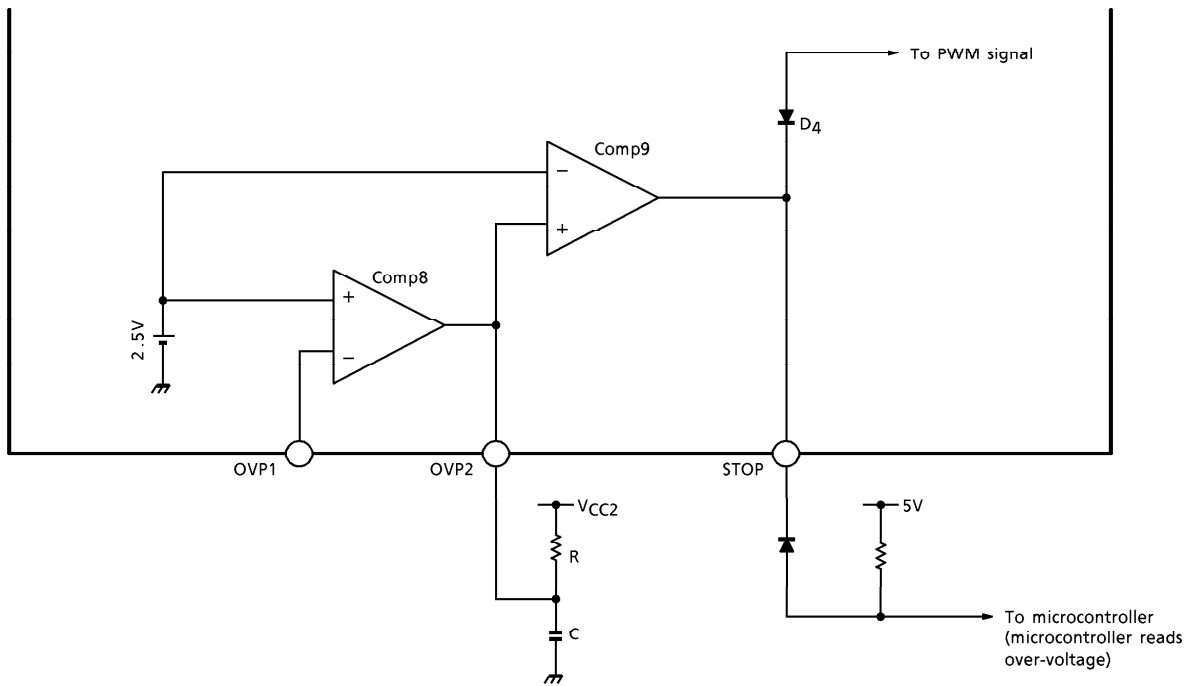

12. Power supply / GND

The device's power supply and GND are as follows. (See block diagram.)

(1) Switching power supply control block  $V_{CC}$  / SGND / PGND (switching driver only)

(2) PWM control block / protector circuit block  $V_{CC2}$  / SGND

(3) IGBT driver block  $V_p$  / PGND

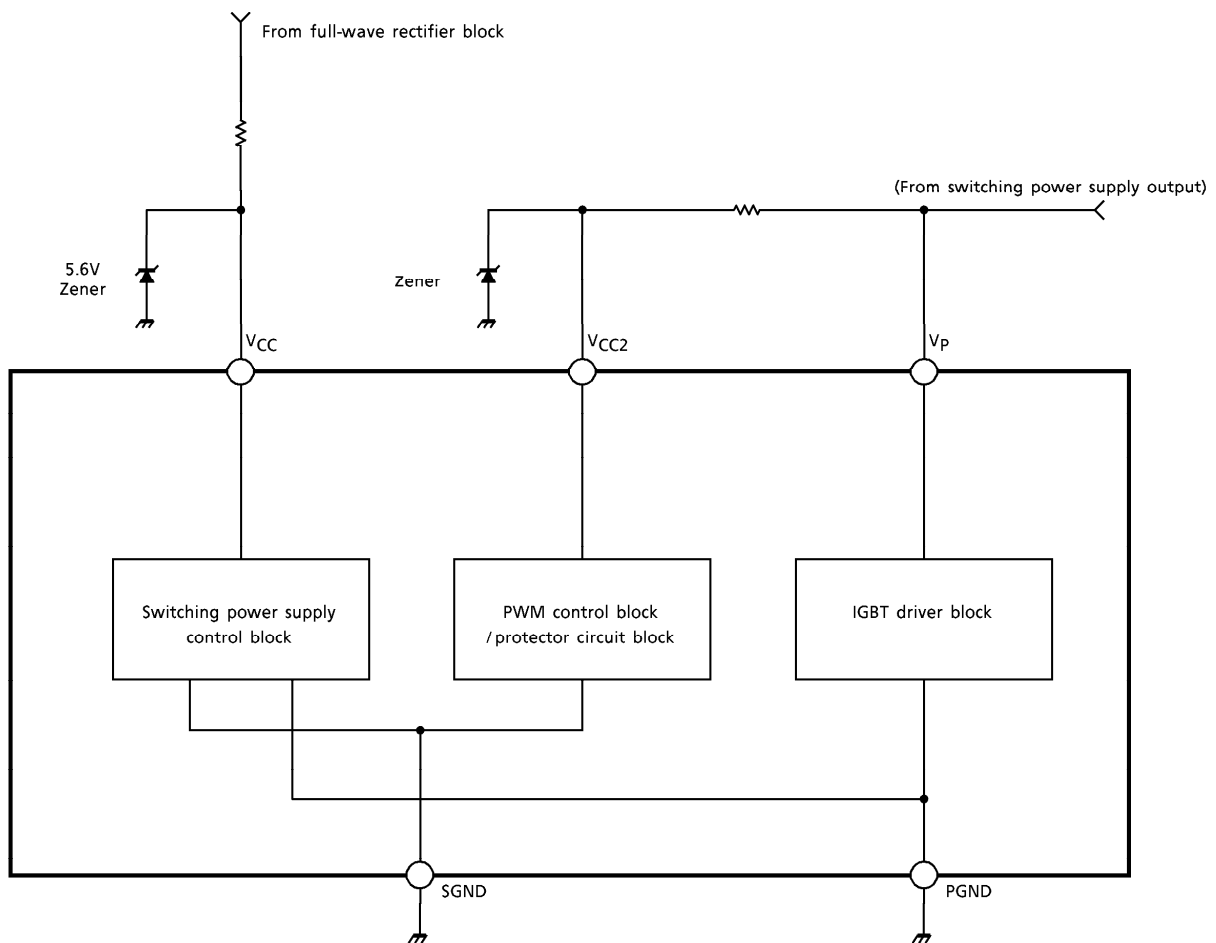

**MAXIMUM RATINGS (Ta = 25°C)**

CHARACTERISTIC	SYMBOL	RATING	UNIT
Supply Voltage	V <sub>p</sub>	25	V
Input Voltage	V <sub>in</sub>	GND - 0.3~V <sub>p</sub> + 0.3	V
Operating Temperature	T <sub>opr</sub>	- 20~85	°C
Storage Temperature	T <sub>stg</sub>	- 55~150	°C
Power Dissipation (*)	P <sub>D</sub>	1.56	W

(\*) When device is operated at Ta > 25°C, power dissipation decreases 12.5mW per degree.

**ELECTRICAL CHARACTERISTICS (Ta = 25°C ; unless otherwise specified : V<sub>CC</sub> = 5.6V, V<sub>CC2</sub> = 12V, V<sub>p</sub> = 20V)**

CHARACTERISTIC	SYMBOL	TEST CIRCUIT	TEST CONDITION	MIN	TYP.	MAX	UNIT
<b>Power Supply Block</b>							
Switching Power Supply Block Startup Power Supply Voltage	V <sub>CC START</sub>	—	At circuit startup, switching power supply block only	4.46	4.8	5.15	V
Switching Power Supply Block Shutdown Power Supply Voltage	V <sub>CC STOP</sub>	—	At circuit shutdown, switching power supply block only	3.8	4.2	4.62	V
Switching Power Supply Block Operating Power Supply Voltage Range	V <sub>CC</sub>	—	—	5.2	—	6.2	V
Control Block Operating Power Supply Voltage	V <sub>CC2</sub>	—	Inverter control block, protector circuit block, IGBT driver block (excluding output stage)	4.5	—	15	V
Power Supply Voltage For Power	V <sub>p</sub>	—	IGBT driver block (output stage only)	15	—	23	V
Operating Current Consumption 1 (V <sub>CC</sub> )	I <sub>CC1</sub>	—	V <sub>CC</sub> = 5.6V, OUT = open (OFF) (switching power supply block)	2	3	5	mA
Operating Current Consumption 2 (V <sub>CC</sub> )	I <sub>CC2</sub>	—	V <sub>CC</sub> = 5.6V, OUT = "L" (ON), no load (switching power supply block only)	2	3	5	mA
Operating Current Consumption 3 (V <sub>CC2</sub> )	I <sub>CC3</sub>	—	V <sub>CC2</sub> = 12V (PWM control block, protector circuit block)	4	6.5	10	mA
Operating Current consumption 4 (V <sub>p</sub> )	I <sub>CC4</sub>	—	V <sub>p</sub> = 20V, PWMOUT = "H", no load	0.7	1.25	1.9	mA
Operating Dissipation Current 5 (V <sub>p</sub> )	I <sub>CC5</sub>	—	V <sub>p</sub> = 20V, PWMOUT = "L", no load	4.2	6.25	8.8	mA

CHARACTERISTIC	SYMBOL	TEST CIR-CUIT	TEST CONDITION	MIN	TYP.	MAX	UNIT
<b>Switching Power Supply Control Block</b>							
<b>Reference Voltage Block</b>							
<b>(V<sub>REF</sub> Pin)</b>							
Reference Voltage	V <sub>ref</sub>	—	No load	2.32	2.5	2.68	V
Power Supply Voltage Fluctuation	ΔV <sub>ref1</sub>	—	V <sub>CC</sub> = 4.2 to 6.0V (after circuit startup), no load	- 10	0	10	mV
Temperature Fluctuation	ΔV <sub>ref2</sub>	—	T <sub>a</sub> = - 25 to 85°C, no load	- 20	0	20	mV
Load Fluctuation	ΔV <sub>ref3</sub>	—	I <sub>OUT</sub> = - 3mA	- 15	0	5	mV
<b>Oscillator Circuit Block (OSC Pin)</b>							
Oscillation Frequency Range	f <sub>OSC1</sub>	—	(Design target)	20	—	100	kHz
<b>Voltage Error Amp (OP Amp1)</b>							
<b>(V<sub>SENSE</sub> Pin)</b>							
Input Dynamic Range	V <sub>in</sub> EAV	—	—	0	—	V <sub>CC</sub> - 1.9	V
Input Bias Current	I <sub>B</sub> EAV	—	—	- 1	—	1	μA
Input Offset Voltage	V <sub>off</sub> EAV	—	—	- 10	0	10	mV
Reference Voltage	V <sub>ref</sub> EAV	—	—	2.32	2.5	2.68	V
<b>(V<sub>AOUT</sub> Pin)</b>							
Output Current	I <sub>out</sub> V <sub>AOUT</sub>	—	—	- 1	—	—	mA
<b>Soft-start/Dead Time Control Block</b>							
<b>(SS/DTC Pin)</b>							
Reference Voltage	V <sub>th</sub> SS/DTC	—	—	2.32	2.5	2.68	V
<b>Output Driver Block</b>							
<b>(OUT Pin)</b>							
Low-level Output Voltage	V <sub>OL</sub> OUT	—	Output = "L", I <sub>OL</sub> = 2mA	—	—	0.3	V
Off Leakage Current	I <sub>off</sub> OUT	—	At V <sub>in</sub> = V <sub>CC</sub> = 5.6V, output OFF	- 1	—	1	μA
<b>Inverter Control Block</b>							
<b>Trigger Comparator (Comp1)</b>							
<b>(TRIGIN + Pin)</b>							
Input Dynamic Range	V <sub>in</sub> TRIG +	—	—	0	—	V <sub>CC2</sub> - 1.9	V
Input Bias Current	I <sub>B</sub> TRIG +	—	—	- 2	—	2	μA
<b>(TRIGIN - Pin)</b>							
Input Dynamic Range	V <sub>in</sub> TRIG -	—	—	0	—	V <sub>CC2</sub> - 1.9	V
Input Bias Current	I <sub>B</sub> TRIG -	—	—	- 2	—	2	μA
<b>(TRIGOUT Pin)</b>							
High-level Output Current	I <sub>OH</sub> TRIG	—	V <sub>CC2</sub> = 12V, output = "H", V <sub>in</sub> = 0V	512	667	952	μA
Low-level Output Voltage	V <sub>OL</sub> TRIG	—	Output = "L", I <sub>OL</sub> = 3mA	—	—	0.3	V

CHARACTERISTIC	SYMBOL	TEST CIR-CUIT	TEST CONDITION	MIN	TYP.	MAX	UNIT
<b>Timing Comparator (Comp2)</b>							
<b>(TIMING IN Pin)</b>							
Input Dynamic Range	V <sub>in</sub> TIMING	—	—	0	—	V <sub>CC2</sub> - 1.9	V
Input Pull-up Resistor	R TIMING	—	—	7	10	13	kΩ
Input Clamp Voltage (D1)	V <sub>F</sub> TIMING	—	I <sub>in</sub> = 3mA	—	—	V <sub>CC2</sub> + 0.9	V
Threshold Voltage	V <sub>th</sub> TIMING	—	V <sub>CC2</sub> = 12V	5.82	6	6.18	V
<b>(TIMING OUT Pin)</b>							
Low-level Output Voltage 1	V <sub>OL</sub> TIMING1	—	Comp 2 side, output = "L", I <sub>OL</sub> = 8mA	—	—	0.3	V
Low-level Output Voltage 2	V <sub>OL</sub> TIMING2	—	Comp 3 side, output = "L", I <sub>OL</sub> = 8mA	—	—	0.3	V
<b>Oscillation Comparator (Comp3), PWM Comparator (Comp4)</b>							
<b>(OSC1 Pin)</b>							
Input Dynamic Range	V <sub>in</sub> OSC1-1	—	(Comp3 side)	0	—	V <sub>CC2</sub> - 1.9	V
Input Bias Current	I <sub>B</sub> OSC1-1	—	(Comp3 side)	-1	—	1	μA
Input Offset Voltage	V <sub>off</sub> OSC1-1	—	(Comp3 side)	-10	0	10	mV
Input Dynamic Range	V <sub>in</sub> OSC1-2	—	(Comp4 side)	0	—	V <sub>CC2</sub> - 1.9	V
Input Bias Current	I <sub>B</sub> OSC1-2	—	(Comp4 side)	-1	—	1	μA
Input Offset Voltage	V <sub>off</sub> OSC1-2	—	(Comp4 side)	-10	0	10	mV
<b>(OSC2 Pin)</b>							
Input Clamp Voltage (D2)	V <sub>F</sub> OSC2	—	I <sub>in</sub> = 7mA	—	—	0.95	V
Oscillator Waveform Upper Limit Voltage	V <sub>H</sub> OSC2	—	V <sub>CC2</sub> = 12V (Design target)	8.53	8.8	9.07	V
Oscillator Waveform Lower Limit Voltage	V <sub>L</sub> OSC2	—	V <sub>CC2</sub> = 12V (Design target)	3.14	3.27	3.49	V
Oscillation Frequency Range	f <sub>OSC</sub>	—	(Design target)	—	—	50	kHz
<b>(PWM-SET Pin)</b>							
Input Dynamic Range	V <sub>in</sub> PWM	—	—	0.3	—	V <sub>CC2</sub> - 1.9	V
Input Offset Range	V <sub>off</sub> PWM	—	—	-10	0	10	mV
Sink Current	I <sub>sink</sub> PWM	—	Internal constant current	-0.5	-1	-2	μA
<b>(PWM-OUT Pin)</b>							
Low-level Output Voltage	V <sub>OL</sub> PWMOUT	—	Output = "L", I <sub>OL</sub> = 3mA	—	—	0.3	V

CHARACTERISTIC	SYMBOL	TEST CIR-CUIT	TEST CONDITION	MIN	TYP.	MAX	UNIT
<b>IGBT Driver Block</b>							
IGBT Drive Comparator (Comp5)							
Threshold Voltage 1	$V_{th}$ PWM1	—	GATE signal L→H	—	2.63	3.0	V
Threshold Voltage 2	$V_{th}$ PWM2	—	GATE signal H→L	1.5	2.27	—	V
PWM Frequency Range	f PWM	—	(Design target)	—	—	50	kHz
Output Driver Block (Sink Side)							
(SI Pin)							
Low-level Output Voltage 1	$V_{OL}$ SI1	—	PWM = "L", $I_{OL} = 30\text{mA}$	—	—	0.7	V
Low-level Output Voltage 2	$V_{OL}$ SI2	—	PWM = "L", $I_{OL} = 1\text{A}$	—	—	3.5	V
Off Leakage Current	$I_{off}$ SI	—	PWM = "H", $V_{in} = V_p = 20\text{V}$	-1	—	1	$\mu\text{A}$
Output Driver Block (Source Side)							
(SO Pin)							
High-level Output Voltage 1	$V_{OH}$ SO1	—	PWM = "H", $I_{OH} = -30\text{mA}$	$V_p - 2$	—	—	V
High-level Output Voltage 2	$V_{OH}$ SO2	—	PWM = "H", $I_{OH} = -200\text{mA}$	$V_p - 5$	—	—	V
Off Leakage Current	$I_{off}$ SO	—	PWM = "L", $V_{in} = 0\text{V}$	-1	—	1	$\mu\text{A}$
IGBT Gate Protection Block							
(DI Pin)							
Input Clamp Voltage (D3)	$V_F$ DI	—	$I_{in} = 500\text{mA}$	—	—	$V_p + 1.5$	V
<b>Protector Circuit Block</b>							
Low-voltage Detection Comparator (Comp6)							
(COMPIN1 Pin)							
Input Dynamic Range	$V_{in}$ COMP1	—	—	0	—	$V_{CC2} - 1.9$	V
Input Bias Current	$I_B$ COMP1	—	—	-2	—	2	$\mu\text{A}$
Input Offset Voltage	$V_{off}$ COMP1	—	—	-10	0	10	mV
Threshold Voltage	$V_{th}$ COMP1	—	—	2.32	2.5	2.68	V

CHARACTERISTIC	SYMBOL	TEST CIR-CUIT	TEST CONDITION	MIN	TYP.	MAX	UNIT
<b>(COMPOUT1 Pin)</b>							
Low-level Output Voltage	V <sub>OL</sub> COMP1	—	Output = "L", I <sub>OL</sub> = 1mA	—	—	0.5	V
<b>Over-Voltage Detection Comparator 1 (Comp7)</b>							
<b>(COMPIN2 Pin)</b>							
Input Dynamic Range	V <sub>in</sub> COMP2	—	—	0	—	V <sub>CC2</sub> - 1.9	V
Input Bias Current	I <sub>B</sub> COMP2	—	—	-2	—	2	μA
Input Offset Voltage	V <sub>off</sub> COMP2	—	—	-10	0	10	mV
Threshold Voltage	V <sub>th</sub> COMP2	—	—	2.32	2.5	2.68	V
<b>(COMPOUT2 Pin)</b>							
Low-level Output Voltage	V <sub>OL</sub> COMP2	—	Output = "L", I <sub>OL</sub> = 1mA	—	—	0.5	V
<b>Over-voltage Detection Comparators 2, 3 (Comp8, Comp9)</b>							
<b>(OVP1 Pin)</b>							
Input Dynamic Range	V <sub>in</sub> OVP1	—	—	0	—	V <sub>CC2</sub> - 1.9	V
Input Bias Current	I <sub>B</sub> OVP1	—	—	-2	—	2	μA
Input Offset Voltage	V <sub>off</sub> OVP1	—	—	-10	0	10	mV
Threshold Voltage	V <sub>th</sub> OVP1	—	—	2.32	2.5	2.68	V
<b>(OVP2 Pin)</b>							
Low-level Output Voltage	V <sub>OL</sub> OVP2	—	(Comp8 side) Output = "L", I <sub>OL</sub> = 10mA	—	—	0.3	V
Input Dynamic Range	V <sub>in</sub> OVP2	—	(Comp9 side)	0	—	V <sub>CC2</sub> - 1.9	V
Input Bias Current	I <sub>B</sub> OVP2	—	(Comp9 side)	-2	—	2	μA
Input Offset Voltage	V <sub>off</sub> OVP2	—	(Comp9 side)	-10	0	10	mV
Threshold Voltage	V <sub>th</sub> OVP2	—	(Comp9 side)	2.32	2.5	2.68	V
<b>(STOP Pin)</b>							
Low-level Output voltage	V <sub>OL</sub> STOP	—	Output = "L", I <sub>OL</sub> = 1mA	—	—	0.25	V

APPLICATION CIRCUIT

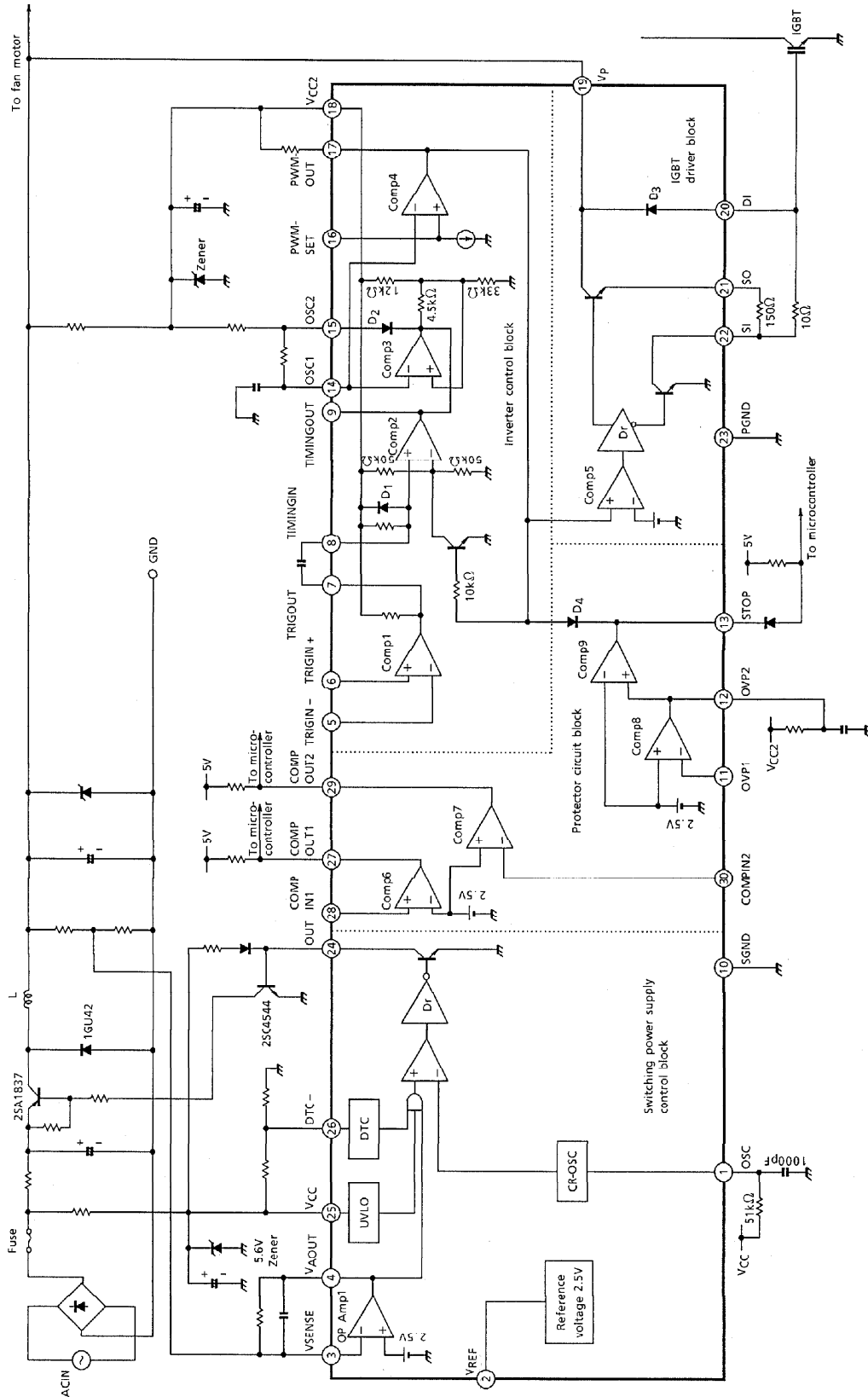



OUTLINE DRAWING  
SDIP30-P-400-1.78

Unit : mm

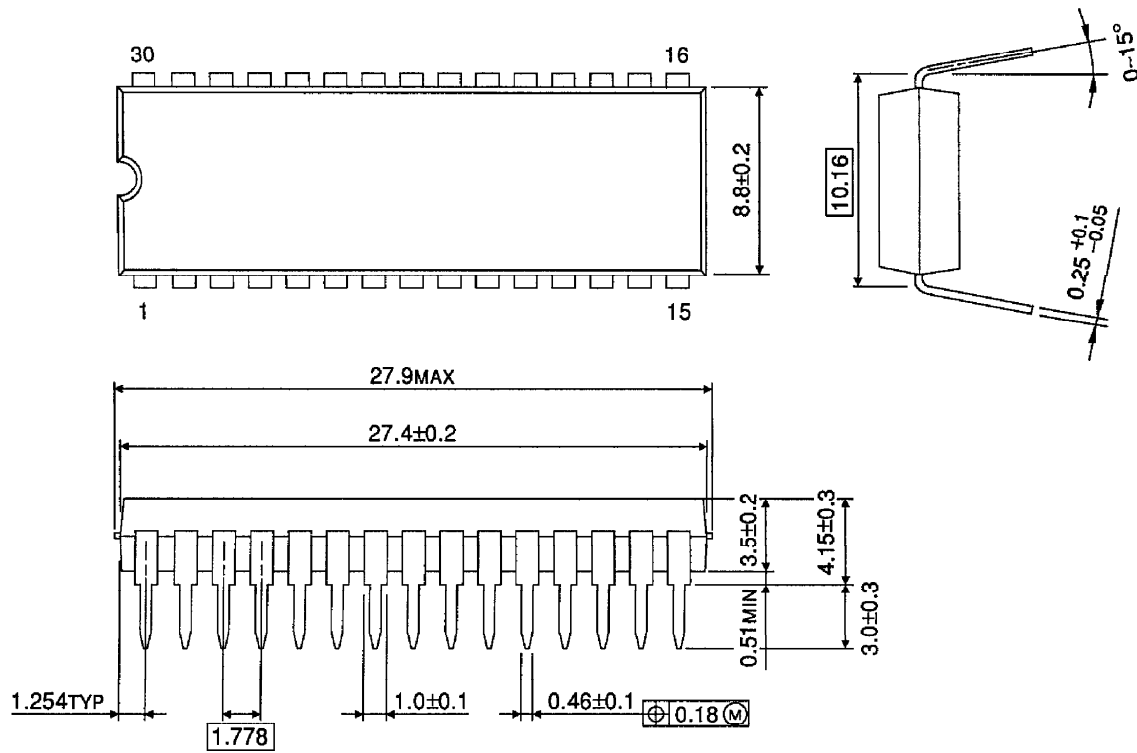

Weight : 1.99g (Typ.)