

TOSHIBA BIPOLAR LINEAR INTEGRATED CIRCUIT SILICON MONOLITHIC

TA8470AF

3 PHASE FULL WAVE BRUSHLESS DC MOTOR DRIVER IC

TA8470AF is a low-noise type 3 Phase Bi-direction Motor Driver IC, developed as a 3 Phase Hall motor driver for VTRs (capstan, cylinder), etc.

FEATURES

- Operating Voltage Range : $V_{CC} = 7 \sim 17V$
- Output Current : $I_O (MAX.) = 1.2A$
- Three Phase Bi-direction, current control mode
- Low Noise (Quasi Sinusoidal Drive)
- Built-in FG Amplifier
- Low Output Impedance with B Class Push-Pull Driver, Capable of Short Brakes (Dumping Brakes)
- Position Detecting Circuit (Hall Input) with High Sensitivity : $V_H = 50mV_{p-p}$
- Enclosed in Space-saving Power Flat Package
- Built-in Thermal Shutdown Circuit

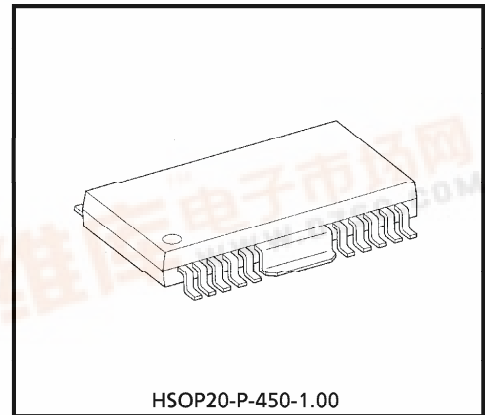

Weight : 0.79g (Typ.)

961001EBA1

● TOSHIBA is continually working to improve the quality and the reliability of its products. Nevertheless, semiconductor devices in general can malfunction or fail due to their inherent electrical sensitivity and vulnerability to physical stress. It is the responsibility of the buyer, when utilizing TOSHIBA products, to observe standards of safety, and to avoid situations in which a malfunction or failure of a TOSHIBA product could cause loss of human life, bodily injury or damage to property. In developing your designs, please ensure that TOSHIBA products are used within specified operating ranges as set forth in the most recent products specifications. Also, please keep in mind the precautions and conditions set forth in the TOSHIBA Semiconductor Reliability Handbook.

● The products described in this document are subject to foreign exchange and foreign trade control laws.

● The information contained herein is presented only as a guide for the applications of our products. No responsibility is assumed by TOSHIBA CORPORATION for any infringements of intellectual property or other rights of the third parties which may result from its use. No license is granted by implication or otherwise under any intellectual property or other rights of TOSHIBA CORPORATION or others.

● The information contained herein is subject to change without notice.



BLOCK DIAGRAM

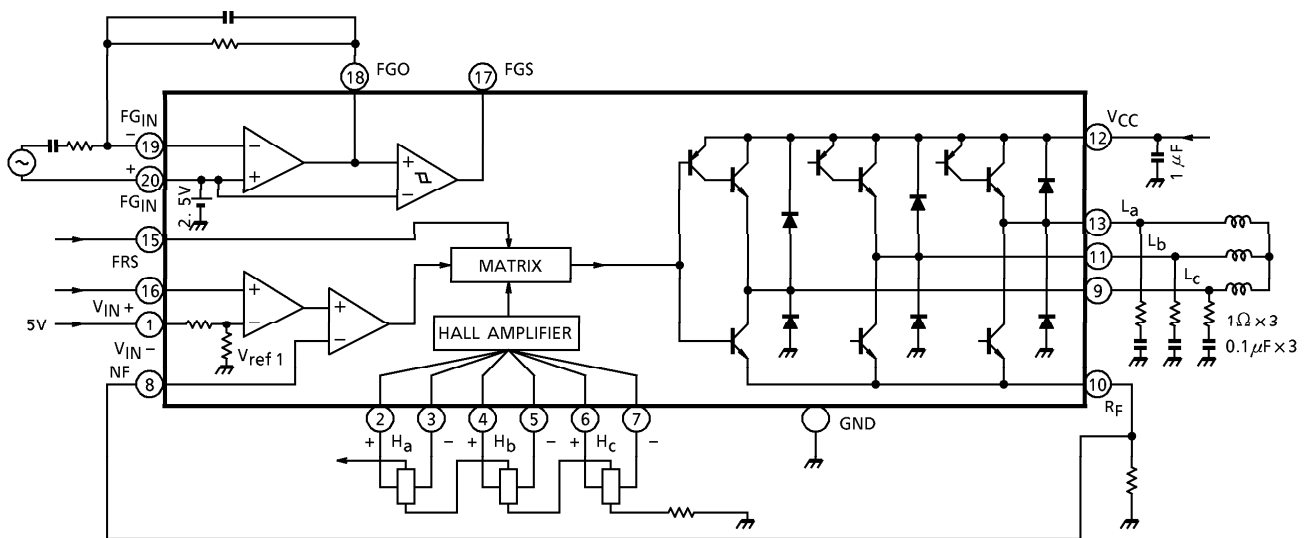

FUNCTION (VIN- = 5V)

MODE	FRS	VIN	OUTPUT
CW	L	$V_{IN+} > 2.3V$	$L_a = H_a - H_b$ $L_b = H_b - H_c$ $L_c = H_c - H_a$
CCW	H	$V_{IN+} > 2.3V$	$L_a = -(H_a - H_b)$ $L_b = -(H_b - H_c)$ $L_c = -(H_c - H_a)$
Standby	M	—	Mid-point potential (Note)
Brake	—	$V_{IN+} < 2.3V$	Mid-point potential (Note)

(Note) Low-impedance Mode

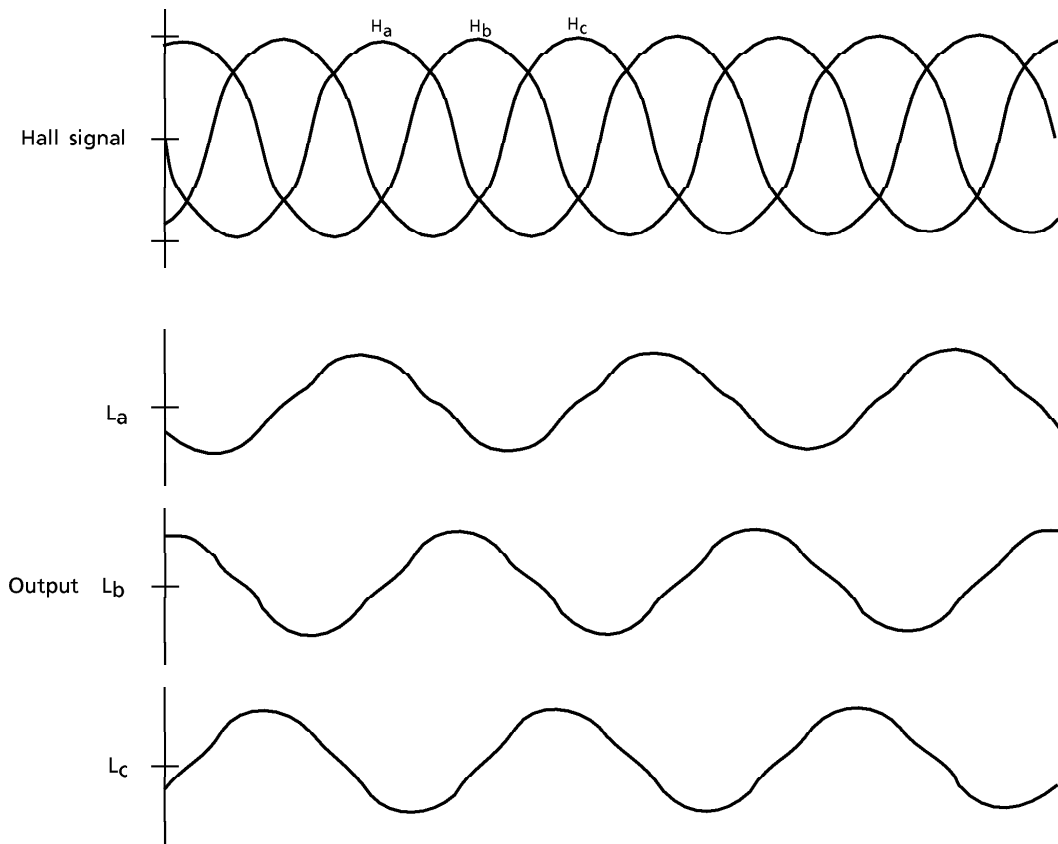

1. Control input circuit

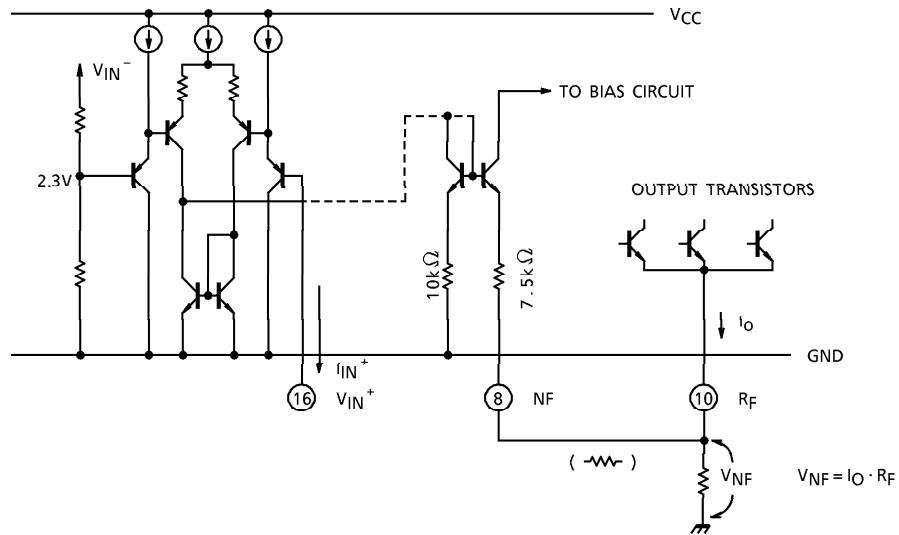

In the case of output current feedback to the motor, connect feedback resistance to R_F pin (10) and feed it back to N_F pin (8).

The feedback amount can be adjusted by connecting a resistor between pin (10) and (8) pin.

2. FG amplifier and schmitt circuit

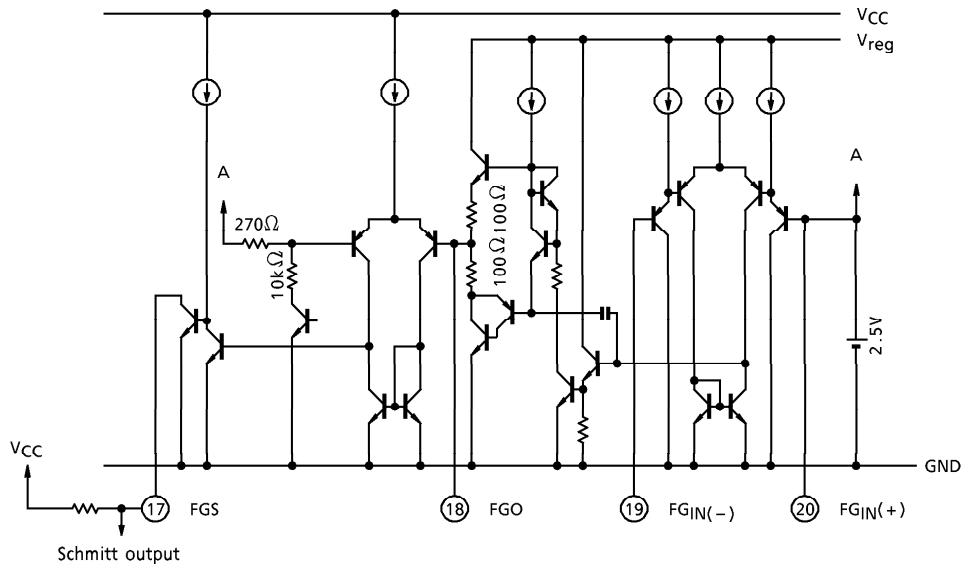

The FG amplifier is stored with internal reference voltage (2.5V), making it possible to directly input the FG signal from pattern FG. The Schmitt circuit stored within can output wave-shaped FG signals.

FGO is in push-pull mode with low impedance.

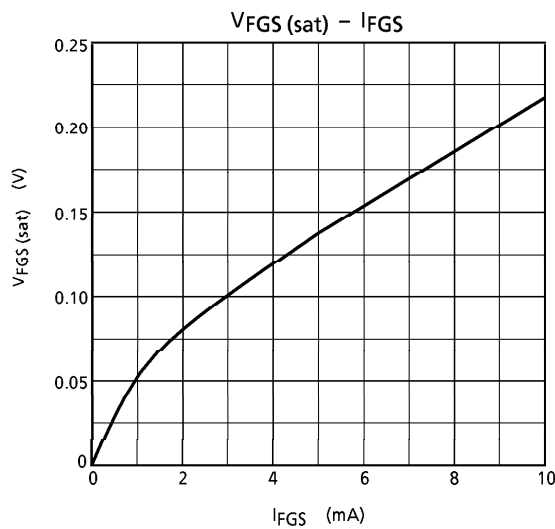

3. FRS section

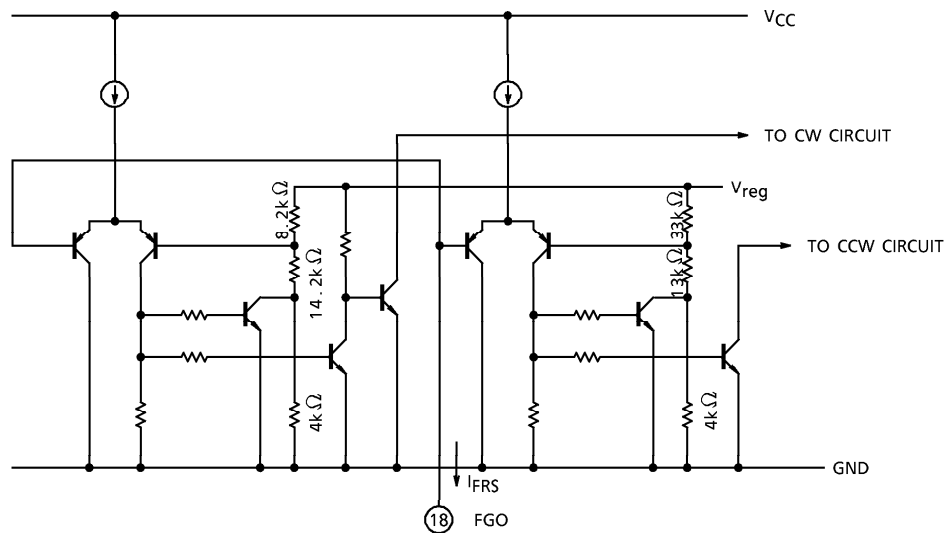

Voltage applied to FRS pin (18) makes it possible to select forward, reverse, and stop modes. For the relationships between FRS, control input, and output, refer to the item on these functions. The relationship between input voltage (V_{FRS}) and input current (I_{FRS}) to the DRS pin (18) is shown as a feature in the following graph :

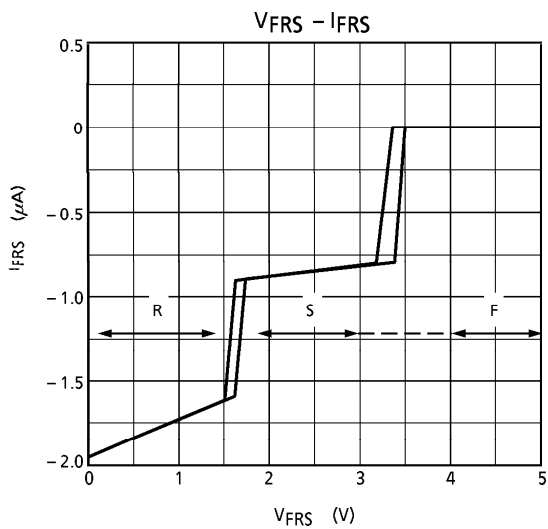

MAXIMUM RATINGS (Ta = 25°C)

CHARACTERISTIC	SYMBOL	RATING	UNIT
Supply Voltage	V _{CC}	18	V
Output Current	I _O	1.2	A
FG Output Current	I _{FGO}	12	mA
	I _{FGS}	14	
Power Dissipation	P _D	(Note 1) 1.0	W
		(Note 2) 3.2	
		(Note 3) 5.8	
Operating Temperature	T _{opr}	- 30~75	°C
Storage Temperature	T _{stg}	- 55~150	°C

(Note 1) Without heat sink

(Note 2) 50 × 50 × 1mm Fe board mounting

(Note 3) Infinite heat sink mounting

ELECTRICAL CHARACTERISTICS ($V_{CC} = 12V$, $V_{IN^-} = 5V$, $T_a = 25^\circ C$)

CHARACTERISTIC		SYMBOL	TEST CIR-CUIT	TEST CONDITIONS	MIN.	TYP.	MAX.	UNIT	
Supply Current		I_{CC1}	1	Output Open, FRS = 2.5V	—	12.5	28	mA	
		I_{CC2}	1	Output Open, FRS = GND	—	14	28		
		I_{CC3}	1	Output Open, FRS = 5V	—	14	28		
Speed Control Circuit	Input Voltage Range	V_{CIN}	2		GND	—	$V_{CC} - 2.5$	V	
	Control Output Voltage Gain	G_{VCO}	2	$V_H = 25mV_{p-p}$	7.5	13	18	dB	
	Input Current	I_{CIN}	2	$V_{IN^+} = GND$ (Sink Current)	—	0.2	5	μA	
	Internal Reference Voltage 1	V_{ref1}	—		2.15	2.30	2.45	V	
Position Detecting Circuit	Common Mode Input Voltage Range	V_{CMRH}	3		1.5	—	5	V	
	Input Current	I_H	3	$V_{INH} = 2.5V$	—	0.2	3	μA	
	Input Voltage Gain	G_{VHO}	4	$V_{IN^+} = 5V$	40	47	51	dB	
Output Circuit	Saturation Voltage	Upper Side	$V_{sat(U)}$	5	$I_O = 1.0A$	—	1.2	1.9	V
		Lower side	$V_{sat(L)}$	5	$I_O = 1.0A$	—	0.7	1.5	
	Quiescent Voltage	V_{OS}	5	$V_{IN^+} = 1.0V$	5.0	5.5	7.0	V	
	Quiescent Voltage Difference	V_{OOF}	5	Each Output to Output	—	25	50	mV	
FG Amp	Open Loop Voltage Gain	G_{VFG}	—	$f_{FG} = 1kHz$	—	70	—	dB	
	Band Width	f_{FG}	6		DC	—	50	kHz	
	FGO Output Amplitude	V_{FGO}	6	$I_{FGO} = 5mA$	1.0	2.1	4	V	
	FGS Output Saturation Voltage	$V_{sat(FGS)}$	6	$I_{FGS} = 4mA$	—	0.15	0.25	V	
	Internal Reference Voltage 2	V_{ref2}	6		2.1	2.5	2.9	V	
	Schmitt Circuit Hysteresis Width	V_{HYS}	6		—	100	250	mV	
Rotation Direction Control Circuit	FWD Operating Voltage	V_{FWD}	5		4.0	—	V_{CC}	V	
	Stop Operating Voltage	V_{STOP}	5		1.9	—	3.1	V	
	Reverse Operating Voltage	V_{REV}	5		0	—	1.3	V	
Thermal Shutdown Operating Temperature		T_{SD}	—		150	—	—	$^\circ C$	

CHARACTERISTICS OF OUTPUT AMP SATURATION VOLTAGE

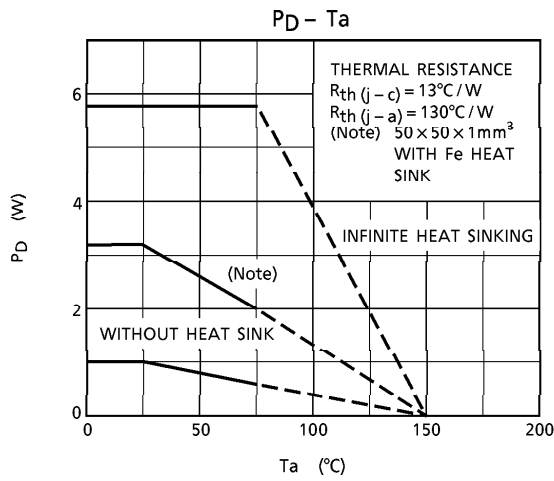
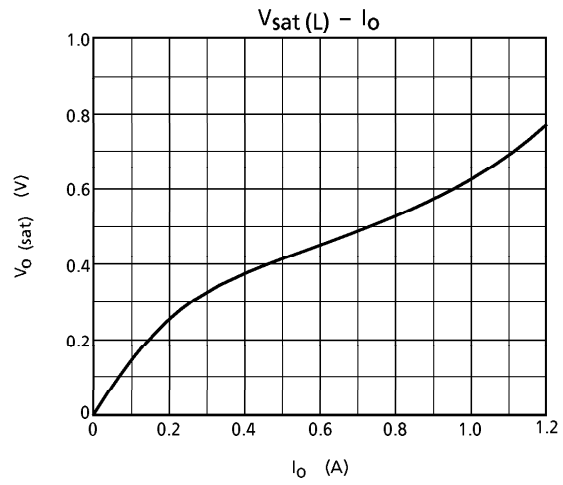
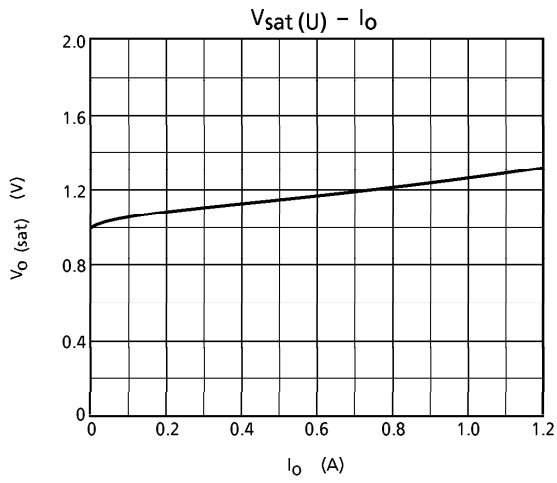

TEST CIRCUIT 1

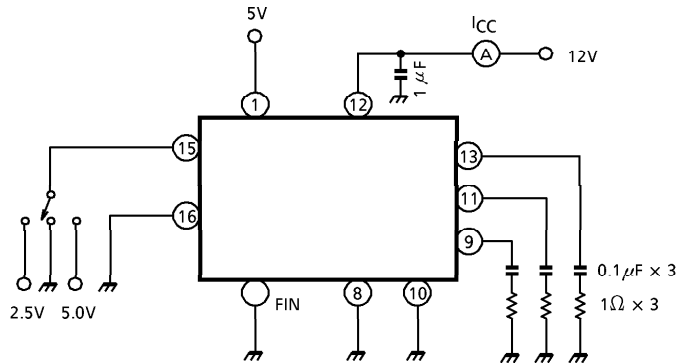

TEST CIRCUIT 2

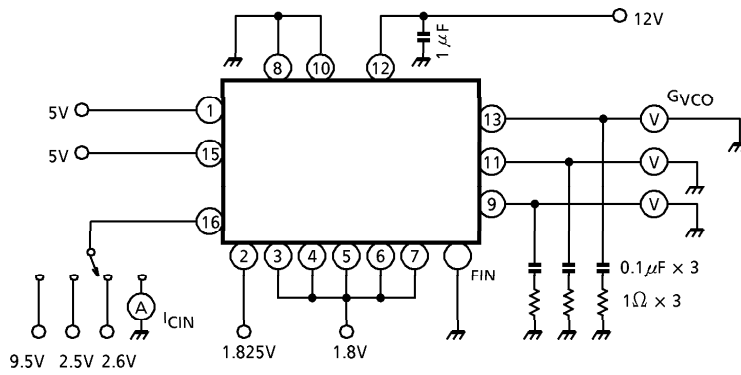

TEST CIRCUIT 3

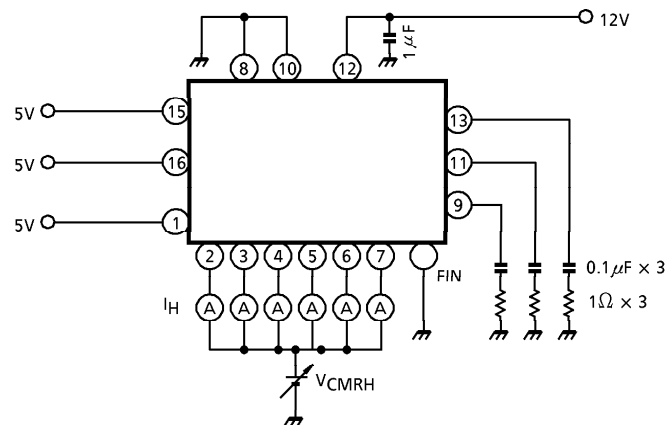

TEST CIRCUIT 4

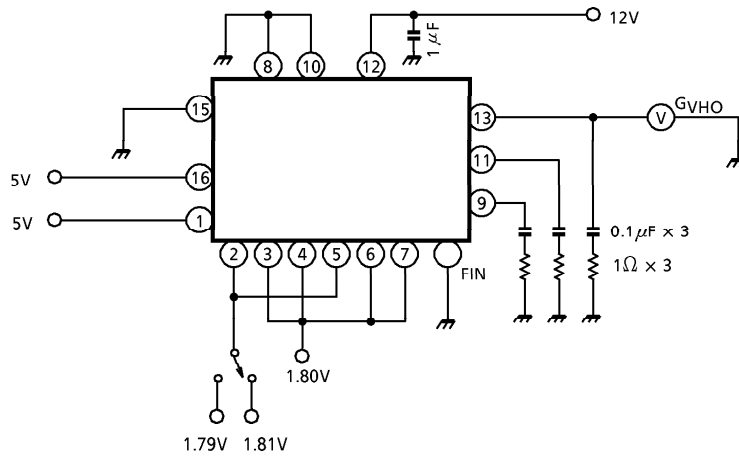

TEST CIRCUIT 5

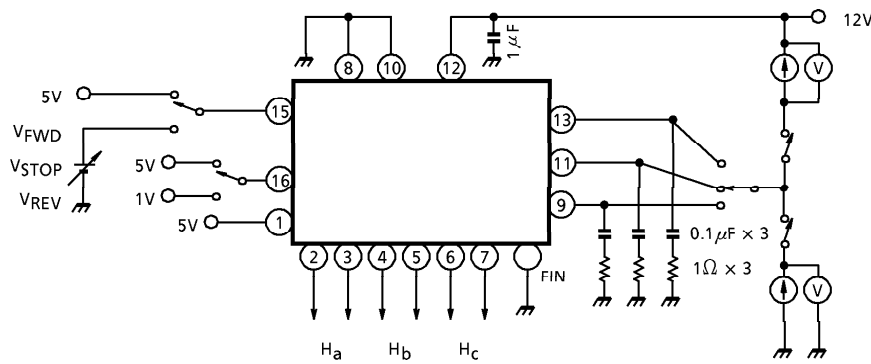

TEST CIRCUIT 6

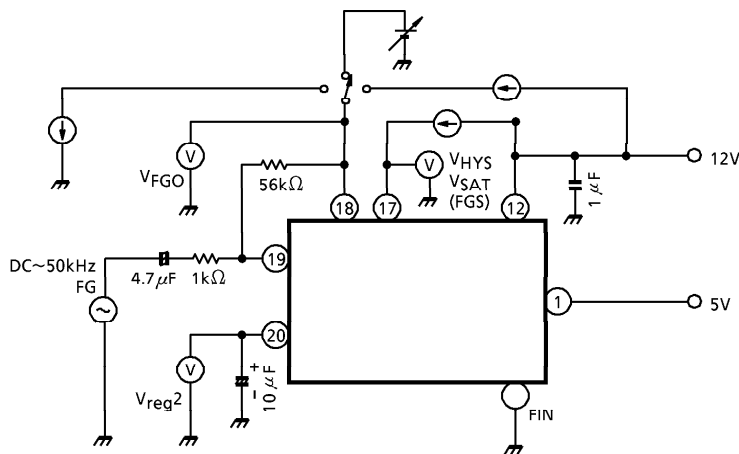

APPLICATION CIRCUIT

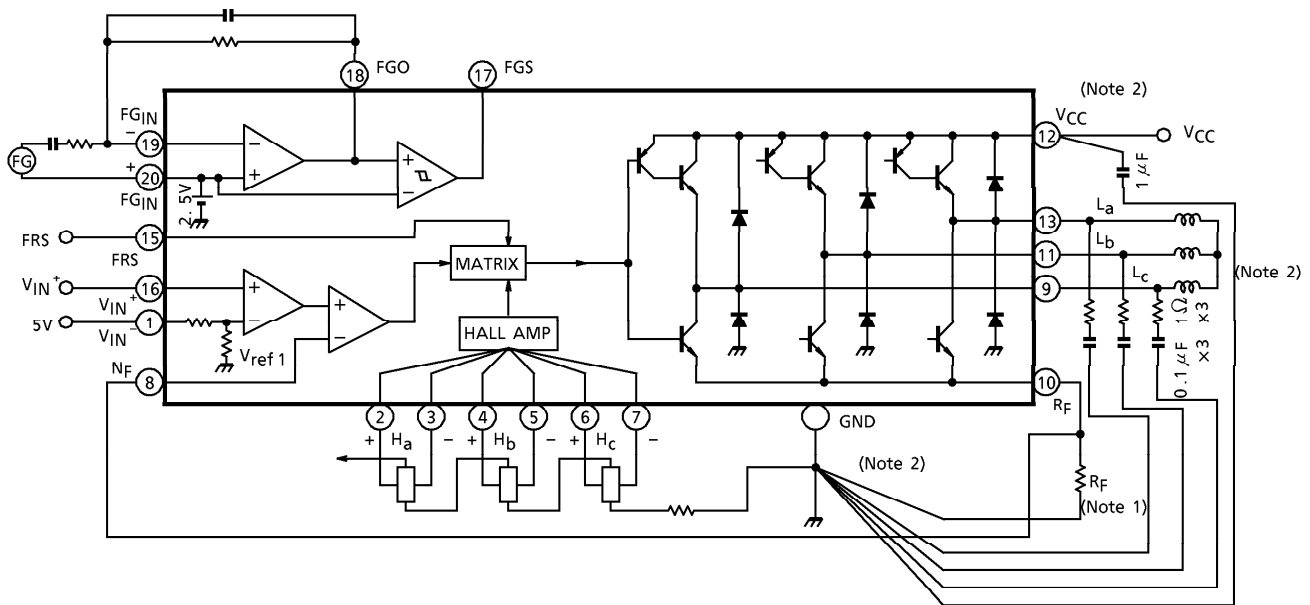

- (Note 1) All output currents flow into R_F pins ; therefore, be sure to provide GND separately from other GND lines.
Care should be taken not to have common impedance among other GND lines, either, in making pattern designs (especially for Hall Sensor GND line).
- (Note 2) Utmost care is necessary in the design of the output line, V_{CC} and GND line since IC may be destroyed due to short-circuit between outputs, air contamination fault, or fault by improper grounding.

OUTLINE DRAWING
HSOP20-P-450-1.00

Unit : mm

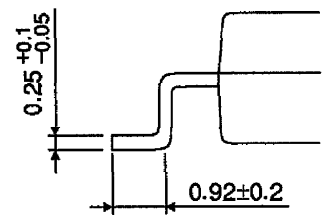
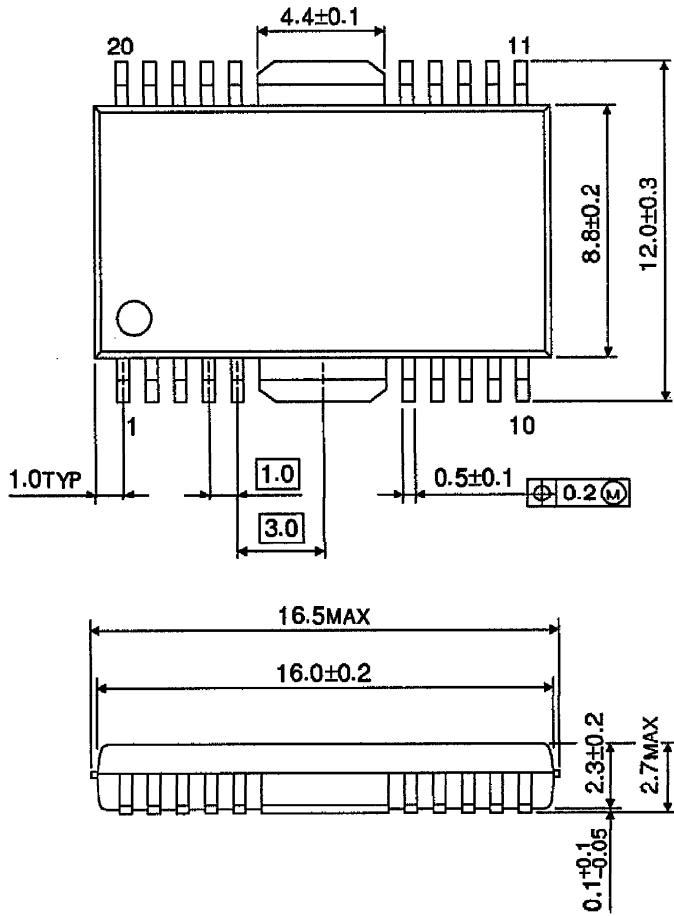

Weight : 0.79g (Typ.)