

FOUR-CHANNEL AUTOMOTIVE DIGITAL AMPLIFIERS

FEATURES

- TAS5414 – Single-Ended Input
- TAS5424 – Differential Input
- Four-Channel Digital Power Amplifier
- Four Analog Inputs, Four BTL Power Outputs
- Typical Output Power per Channel at 10% THD+N
 - 28 W/Ch Into 4 Ω at 14.4 Vdc
 - 45 W/Ch Into 2 Ω at 14.4 Vdc
 - 58 W/Ch Into 4 Ω at 21 Vdc
 - 116 W/Ch Into 2 Ω at 21 Vdc PBTL
- Channels Can Be Paralleled (PBTL) for 1- Ω Applications
- THD+N < 0.02%, 1 kHz, 1 W Into 4 Ω
- Patented Pop- and Click-Reduction Technology
 - Soft Muting With Gain Ramp Control
 - Common-Mode Ramping
- Patented AM Interference Avoidance
- Patented Cycle-by-Cycle Current Limit
- 75-dB PSRR
- Four-Address I²C Serial Interface for Device Configuration and Control
- Configurable Channel Gains: 12-dB, 20-dB, 26-dB, 32-dB
- Load Diagnostic Functions:
 - Output Open and Shorted Load
 - Output-to-Power and -to-Ground Shorts
 - Patented Tweeter Detection
- Protection and Monitoring Functions:
 - Short-Circuit Protection
 - Load-Dump Protection to 50 V
 - Fortuitous Open Ground and Power Tolerant
 - Patented Output DC Level Detection While Music Playing
 - Overtemperature Protection
 - Over- and Undervoltage Conditions
 - Clip Detection
- 36-Pin PSOP3 (DKD) Power SOP Package

With Heat Slug Up for the TAS5414

- 44-Pin PSOP3 (DKD) Power SOP Package With Heat Slug Up for the TAS5424
- Designed for Automotive EMC Requirements
- Pb-Free Soldering Supported
- AECQ100 Compliant
- ISO9000:2002 TS16949 Certified
- –40°C to 105°C Ambient Temperature Range

APPLICATIONS

- High-power OEM/retail head units and amplifier modules where feature densities and system configurations require reduction in heat from the audio power amplifier

DESCRIPTION

The TAS5414 and TAS5424 are four-channel digital audio amplifiers designed for use in automotive head units and external amplifier modules. The TAS5414 and TAS5424 provide four channels at 23 W continuously into 4 Ω at less than 1% THD+N from a 14.4-V supply. Each channel can also deliver 38 W into 2 Ω at 1% THD+N. The TAS5414 uses single-ended analog inputs, while the TAS5424 employs differential inputs for increased immunity to common-mode system noise. The digital PWM topology of the TAS5414 and TAS5424 provides dramatic improvements in efficiency over traditional linear amplifier solutions. This reduces the power dissipated by the amplifier by a factor of ten under typical music playback conditions. High efficiency is accomplished without the need for complicated power-supply schemes. Multiple TAS5414s or TAS5424s can be synchronized to meet high-channel-count applications.

The TAS5414 and TAS5424 incorporate all the functionality needed to perform in the demanding OEM applications area. They have built-in load diagnostic functions for detecting and diagnosing misconnected outputs to help to reduce test time during the manufacturing process.



Please be aware that an important notice concerning availability, standard warranty, and use in critical applications of Texas Instruments semiconductor products and disclaimers thereto appears at the end of this data sheet.

TAS5414 FUNCTIONAL BLOCK DIAGRAM

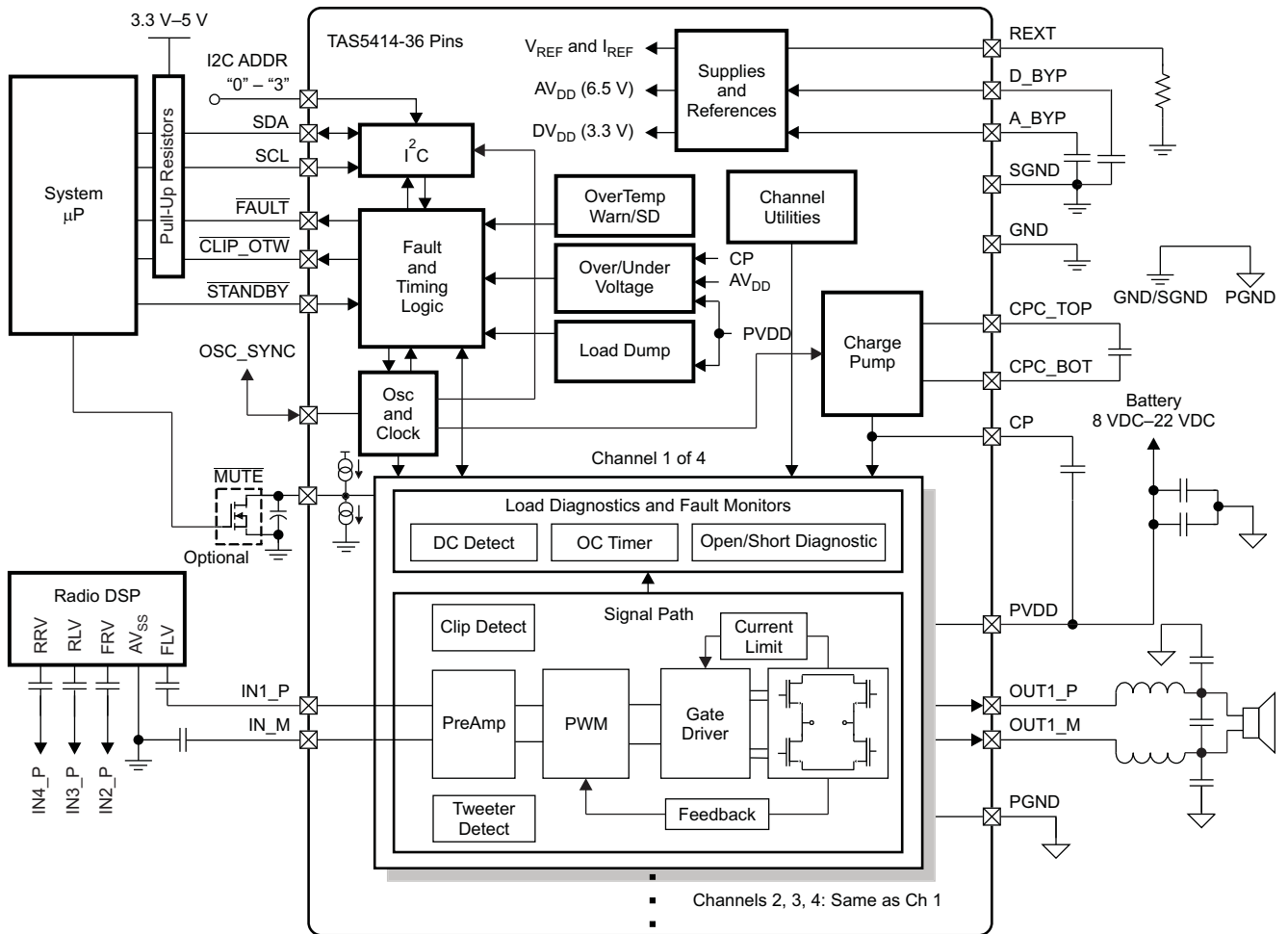

B0198-01

TAS5424 FUNCTIONAL BLOCK DIAGRAM

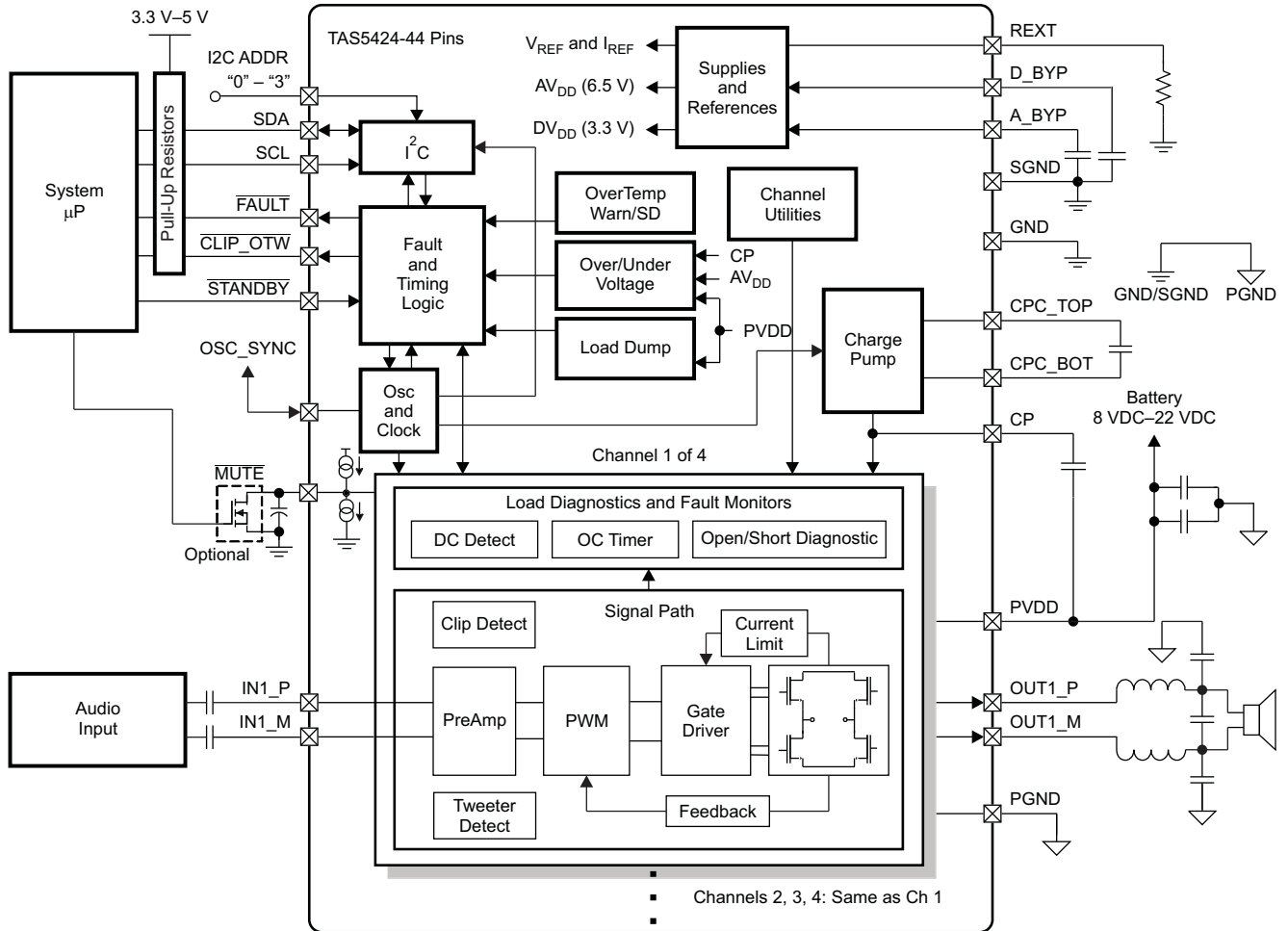

B0198-02

PIN ASSIGNMENTS AND FUNCTIONS

The pin assignments for the TAS5414 and TAS5424 are shown as follows.

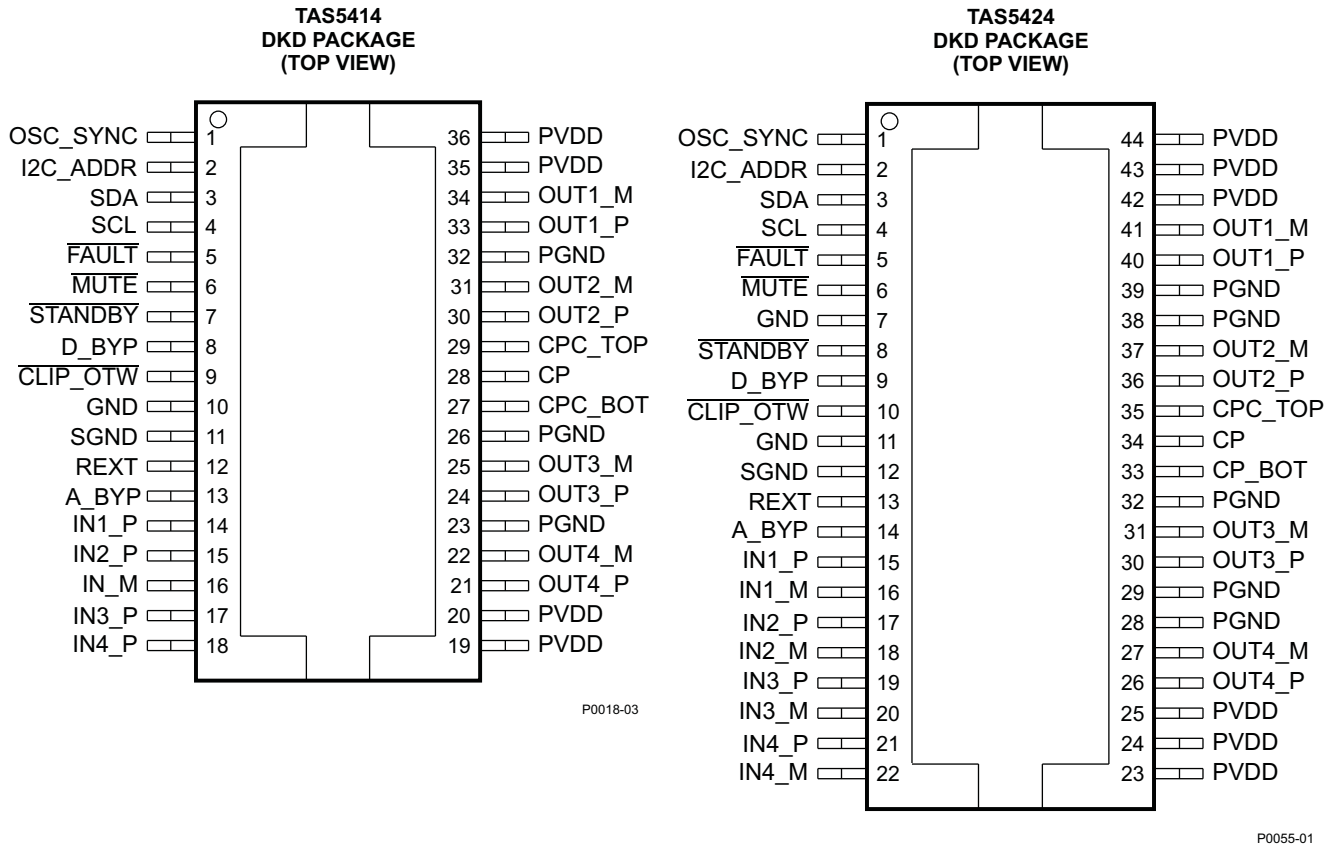

Table 1. TERMINAL FUNCTIONS

| TERMINAL | | | TYPE ⁽¹⁾ | DESCRIPTION |
|----------|----------------|------------------------|---------------------|---|
| NAME | DKD Package | | | |
| | TAS5414 NO. | TAS5424 NO. | | |
| A_BYP | 13 | 14 | PBY | Bypass capacitor for the AVDD analog regulator |
| CLIP_OTW | 9 | 10 | DO | Open-drain CLIP, OTW, or logical OR of the CLIP and OTW outputs. It also reports tweeter detection during tweeter mode. |
| CP | 28 | 34 | CP | Top of main storage capacitor for charge pump (bottom goes to PVDD) |
| CPC_BOT | 27 | 33 | CP | Bottom of flying capacitor for charge pump |
| CPC_TOP | 29 | 35 | CP | Top of flying capacitor for charge pump |
| D_BYP | 8 | 9 | PBY | Bypass pin for DVDD regulator output |
| FAULT | 5 | 5 | DO | Global fault output (open drain): UV, OV, OTSD, OCSD, DC |
| GND | 10 | 7, 11 | DG | Ground |
| I2C_ADDR | 2 | 2 | AI | I ² C address bit |
| IN1_M | N/A | 16 | AI | Inverting analog input for channel 1 (TAS5424 only) |
| IN1_P | 14 | 15 | AI | Non-inverting analog input for channel 1 |
| IN2_M | N/A | 18 | AI | Inverting analog input for channel 2 (TAS5424 only) |
| IN2_P | 15 | 17 | AI | Non-inverting analog input for channel 2 |
| IN3_M | N/A | 20 | AI | Inverting analog input for channel 3 (TAS5424 only) |
| IN3_P | 17 | 19 | AI | Non-inverting analog input for channel 3 |
| IN4_M | N/A | 22 | AI | Inverting analog input for channel 4 (TAS5424 only) |
| IN4_P | 18 | 21 | AI | Non-inverting analog input for channel 4 |
| IN_M | 16 | N/A | ARTN | Signal return for the 4 analog channel inputs (TAS5414 only) |
| MUTE | 6 | 6 | AI | Gain ramp control: mute (low), play (high) |
| OSC_SYNC | 1 | 1 | DI/DO | Oscillator sync input from master or output to slave amplifiers (20 MHz divided by 5, 6, or 7) |
| OUT1_M | 34 | 41 | PO | – polarity output for bridge 1 |
| OUT1_P | 33 | 40 | PO | + polarity output for bridge 1 |
| OUT2_M | 31 | 37 | PO | – polarity output for bridge 2 |
| OUT2_P | 30 | 36 | PO | + polarity output for bridge 2 |
| OUT3_M | 25 | 31 | PO | – polarity output for bridge 3 |
| OUT3_P | 24 | 30 | PO | + polarity output for bridge 3 |
| OUT4_M | 22 | 27 | PO | – polarity output for bridge 4 |
| OUT4_P | 21 | 26 | PO | + polarity output for bridge 4 |
| PGND | 23, 26, 32 | 28, 29, 32, 38, 39 | PGND | Power GND |
| PVDD | 19, 20, 35, 36 | 23, 24, 25, 42, 43, 44 | PWR | PVDD supply |
| REXT | 12 | 13 | AI | Precision resistor pin to set clock frequency |
| SCL | 4 | 4 | DI | I ² C clock input from system I ² C master |
| SDA | 3 | 3 | DI/DO | I ² C data I/O for communication with system I ² C master |
| SGND | 11 | 12 | AG/DG | Signal ground (analog and digital signal ground) |
| STANDBY | 7 | 8 | DI | Active-low STANDBY pin. Standby (low), power up (high) |

(1) DI = digital input, DO = digital output, AI = analog input, ARTN = analog signal return, PWR = power supply, PGND = power ground, PBY = power bypass, PO = power output, AG = analog ground, DG = digital ground, CP = charge pump.

ABSOLUTE MAXIMUM RATINGS

over operating free-air temperature range (unless otherwise noted)

| | | | VALUE | UNIT |
|-----------------------------------|--|--|----------------------|------------------|
| PVDD | DC supply voltage range | Relative to PGND | –0.3 to 30 | V |
| PVDD _{MAX} | Pulsed supply voltage range | t ≤ 100 ms exposure | –1 to 50 | V |
| PVDD _{RAMP} | Supply voltage ramp rate | Voltage rising up to PVDD _{MAX} | 25 | V/ms |
| I _{PVDD} | Externally imposed dc supply current per PVDD or PGND pin | | ±12 | A |
| I _{PVDD_MAX} | Pulsed supply current per PVDD pin (one shot) | t < 100 ms | 17 | A |
| I _O | Maximum allowed dc current per output pin | | ±13.5 | A |
| I _{O_MAX} ⁽¹⁾ | Pulsed output current per output pin (single pulse) | t < 100 ms | ±17 | A |
| I _{IN_MAX} | Maximum current, all digital and analog input pins ⁽²⁾ | DC or pulsed | ±1 | mA |
| I _{MUTE_MAX} | Maximum current on $\overline{\text{MUTE}}$ pin | DC or pulsed | ±20 | mA |
| I _{IN_ODMAX} | Maximum sinking current for open-drain pins | | 7 | mA |
| V _{LOGIC} | Input voltage range for logic pin relative to SGND (SCL and SDA pins) | Supply voltage range: 6.5 V < PVDD < 24 V | –0.3 to 7 | V |
| V _{I2C_ADDR} | Input voltage range for I2C_ADDR pin relative to SGND | Supply voltage range: 6.5 V < PVDD < 24 V | –0.3 to 7 | V |
| V _{STANDBY} | Input voltage range for $\overline{\text{STANDBY}}$ pin | Supply voltage range: 6.5 V < PVDD < 24 V | –0.3 to 5.8 | V |
| V _{OSC_SYNC} | Input voltage range for OSC_SYNC pin relative to SGND | Supply voltage range: 6.5 V < PVDD < 24 V | –0.3 to 3.6 | V |
| V _{AIN_MAX} | Maximum instantaneous input voltage (per pin), analog input pins | Supply voltage range: 6.5 V < PVDD < 24 V | 6.5 | V |
| V _{AIN_AC_MAX_5414} | Maximum ac coupled input voltage for TAS5414 ⁽²⁾ , analog input pins | Supply voltage range: 6.5 V < PVDD < 24 V | 1.9 | V _{rms} |
| V _{AIN_AC_MAX_5424} | Maximum ac coupled differential input voltage for TAS5424 ⁽²⁾ , analog input pins | Supply voltage range: 6.5 V < PVDD < 24 V | 3.8 (1.9 per pin) | V _{rms} |
| V _{AIN_DC} | Input voltage range for analog pin relative to AGND (INx pins) | Supply voltage range: 6.5 V < PVDD < 24 V | –0.3 to 6.5 | V |
| T _J | Maximum operating junction temperature range | | –55 to 150 | °C |
| T _{stg} | Storage temperature range | | –55 to 150 | °C |
| T _{SOLDER} | Lead temperature during soldering 1,6 mm (1/16 inch) from case for 10 seconds | | 260 | °C |
| Power dissipation | Continuous power dissipation | T _{case} = 70°C | 80 | W |

- (1) Pulsed current ratings are maximum survivable currents externally applied to the TAS5414 and TAS5424. High currents may be encountered during reverse battery, fortuitous open ground, and fortuitous open supply fault conditions.
- (2) See [Application Information](#) section for information on analog input voltage and ac coupling.

THERMAL CHARACTERISTICS

| PARAMETER | VALUE | UNIT |
|--|---|------|
| R _{θJC} Junction-to-case (heat slug) thermal resistance | 1 | °C/W |
| R _{θJA} Junction-to-ambient thermal resistance | This device is not intended to be used without a heatsink. Therefore, R _{θJA} is not specified. See the Thermal Information section. | °C/W |

RECOMMENDED OPERATING CONDITIONS⁽¹⁾

| | | | MIN | TYP | MAX | UNIT |
|--------------------------------------|---|---|------|----------|-----------------------|------------------|
| PVDD _{OP} | DC supply voltage range relative to PGND | | 8 | 14.4 | 22 | V |
| PVDD _{I2C} | DC supply voltage range for I ² C reporting | | 6 | 14.4 | 26.5 | V |
| V _{AIN_5414} ⁽²⁾ | Analog audio input signal level (TAS5414) | AC-coupled input voltage | 0 | | 0.25–1 ⁽³⁾ | V _{rms} |
| V _{AIN_5424} ⁽²⁾ | Analog audio input signal level (TAS5424) | AC-coupled input voltage | 0 | | 0.5–2 ⁽³⁾ | V _{rms} |
| f _{AUDIO_TW} | Audio frequency for tweeter detect | | 10 | 20 | 25 | kHz |
| T _A | Ambient temperature | | –40 | | 105 | °C |
| T _J | Junction temperature | An adequate heat sink is required to keep T _J within specified range | –40 | | 115 | °C |
| R _L | Nominal speaker load impedance | | 2 | 4 | | Ω |
| V _{PU} | Pullup voltage supply (for open-drain logic outputs) | | 3 | 3.3 or 5 | 5.5 | V |
| R _{PU_EXT} | External pullup resistor on open-drain logic outputs | Resistor connected between open-drain logic output and V _{PU} supply | 10 | 50 | 100 | kΩ |
| R _{PU_I2C} | I ² C pullup resistance on SDA and SCL pins | | 1 | 5 | 10 | kΩ |
| R _{I2C_ADD} | Total resistance of voltage divider for I ² C address slave 1 or slave 2, connected between D _{BYP} and SGND pins | | 10 | | 100 | kΩ |
| R _{REXT} | External resistance on REXT pin | 1% tolerance required | 19.8 | 20 | 20.2 | kΩ |
| C _{D_BYP} | External capacitance on D _{BYP} pin | | 10 | | 120 | nF |
| C _{A_BYP} | External capacitance on A _{BYP} pin | | 10 | | 120 | nF |
| C _{IN} | External capacitance to analog input pin in series with input signal | | | 1 | | μF |
| C _{FLY} | Flying capacitor on charge pump | | 0.47 | 1 | 1.5 | μF |
| C _P | Charge pump capacitor | | 0.47 | 1 | 1.5 | μF |
| C _{MUTE} | Capacitance on MUTE pin | | 3.3 | 330 | | nF |
| C _{OSCSYNC_MAX} | Allowed loading capacitance on OSC_SYNC pin | | | 5 | | pF |

- (1) The *Recommended Operating Conditions* table specifies only that the device is functional in the given range. See the *Electrical Characteristics* table for specified performance limits.
- (2) Signal input for full unclipped output with gains of 32 dB, 26 dB, 20 dB, and 12 dB
- (3) Maximum recommended input voltage is determined by the gain setting.

ELECTRICAL CHARACTERISTICS

Test conditions (unless otherwise noted): $T_{Case} = 25^{\circ}C$, $PVDD = 14.4 V$, $R_L = 4 \Omega$, $f_s = 417 kHz$, $R_{ext} = 20 k\Omega$, master mode operation (see application diagram)

| PARAMETER | | TEST CONDITIONS | MIN | TYP | MAX | UNIT | |
|---|--|--|------|----------|----------|------------|-----|
| OPERATING CURRENT | | | | | | | |
| I_{PVDD_IDLE} | PVDD idle current | All four channels running in MUTE mode | | 240 | 300 | mA | |
| I_{PVDD_HI-Z} | | All four channels in Hi-Z mode | | 80 | | | |
| I_{PVDD_STBY} | PVDD standby current | STANDBY mode, $T_J \leq 85^{\circ}C$ | | 2 | 20 | μA | |
| OUTPUT POWER | | | | | | | |
| P_{OUT} | Output power per channel | 4 Ω , PVDD = 14.4V, THD+N \leq 1%, 1 kHz, $T_c = 75^{\circ}C$ | | 23 | | W | |
| | | 4 Ω , PVDD = 14.4V, THD+N = 10%, 1 kHz, $T_c = 75^{\circ}C$ | 25 | 28 | | | |
| | | 4 Ω , PVDD = 14.4V, square wave, 1 kHz, $T_c = 75^{\circ}C$ | | 43 | | | |
| | | 4 Ω , PVDD = 21 V, THD+N = 1%, 1 kHz, $T_c = 75^{\circ}C$ | | 47 | | | |
| | | 4 Ω , PVDD = 21 V, THD+N = 10%, 1 kHz, $T_c = 75^{\circ}C$ | 50 | 58 | | | |
| | | 2 Ω , PVDD = 14.4V, THD+N = 1%, 1 kHz, $T_c = 75^{\circ}C$ | | 38 | | | |
| | | 2 Ω , PVDD = 14.4V, THD+N = 10%, 1 kHz, $T_c = 75^{\circ}C$ | 40 | 45 | | | |
| | | 2 Ω , PVDD = 14.4 V, square wave 1 kHz, $T_c = 75^{\circ}C$ | | 70 | | | |
| | | PBTL 2- Ω operation, PVDD = 21 V, THD+N = 10%, 1 kHz, $T_c = 75^{\circ}C$ | | 116 | | | |
| | | PBTL 1- Ω operation, PVDD = 14.4 V, THD+N = 10%, 1 kHz, $T_c = 75^{\circ}C$ | | 90 | | | |
| EFF_P | Power efficiency | 4 channels operating, 23W output power/ch, L = 10 μH , $T_J \leq 85^{\circ}C$ | | 90% | | | |
| AUDIO PERFORMANCE | | | | | | | |
| V_{NOISE} | Noise voltage at output | G = 26 dB, zero input, AES17 filter, and A-weighting | | 60 | 100 | μV | |
| Crosstalk | Channel crosstalk | 1W, G = 26 dB, 1 kHz | 60 | 75 | | dB | |
| $CMRR_{5424}$ | Common-mode rejection ratio (TAS5424) | 1 kHz, 1 Vrms referenced to SGND, G = 26 dB | 60 | 75 | | dB | |
| PSRR | Power supply rejection ratio | G = 26 dB, PVDD = 14.4 Vdc + 1 Vrms, f = 1 kHz | 60 | 75 | | dB | |
| THD+N | Total harmonic distortion + noise | P = 1 W, G = 26 dB, f = 1 kHz, $0^{\circ}C \leq T_J \leq 75^{\circ}C$ | | 0.02% | 0.1% | | |
| f_s | Switching frequency | Switching frequency selectable for AM interference avoidance | | 336 | 357 | 378 | kHz |
| | | | | 392 | 417 | 442 | |
| | | | | 470 | 500 | 530 | |
| R_{AIN} | Analog input resistance | Internal shunt resistance on each input pin | 60 | 80 | 100 | k Ω | |
| V_{IN_CM} | Common-mode input voltage (non-clipping) | AC-coupled common-mode input voltage (zero differential input) | | | 1.3 | Vrms | |
| V_{CM_INT} | Internal common-mode input bias voltage | Internal bias applied to IN_M pin | | 3.25 | | V | |
| G | Voltage gain (V_O/V_{IN}) | Source impedance = 0 Ω | | 11 | 12 | 13 | dB |
| | | | | 19 | 20 | 21 | |
| | | | | 25 | 26 | 27 | |
| | | | | 31 | 32 | 33 | |
| G_{CH} | Channel-to-channel variation | Any gain commanded | -1 | 0 | 1 | dB | |
| t_{CM} | Output-voltage common-mode ramping time | | | 35 | | ms | |
| t_{GAIN} | Gain ramping time | External $C_{MUTE} = 330 nF$ | | 30 | | ms | |
| PWM OUTPUT STAGE | | | | | | | |
| R_{Dson} | FET Drain-to-source resistance | Not including bond wire resistance, $T_J = 25^{\circ}C$ | | 75 | 95 | m Ω | |
| V_{O_OFFSET} | Output offset voltage | Zero input signal and G = 26 dB | | ± 10 | ± 25 | mV | |
| PVDD OVER VOLTAGE (OV) PROTECTION | | | | | | | |
| V_{OV} | PVDD over voltage shutdown | | 22.1 | 23.7 | 26.3 | V | |
| LOAD DUMP (LD) PROTECTION | | | | | | | |
| $V_{LD_SD_SET}$ | Load-dump shutdown voltage | | 26.6 | 29 | 32 | V | |
| $V_{LD_SD_CLEAR}$ | Recovery voltage for load-dump shutdown | | 23.5 | 26.4 | 28.4 | V | |
| PVDD UNDER VOLTAGE (UV) PROTECTION | | | | | | | |
| V_{UV_SET} | PVDD under voltage shutdown | | 6.5 | 7 | 7.5 | V | |
| V_{UV_CLEAR} | Recovery voltage for PVDD UV | | 7 | 7.5 | 8 | V | |

ELECTRICAL CHARACTERISTICS (continued)

Test conditions (unless otherwise noted): $T_{Case} = 25^{\circ}C$, $PVDD = 14.4 V$, $R_L = 4 \Omega$, $f_s = 417 kHz$, $R_{ext} = 20 k\Omega$, master mode operation (see application diagram)

| PARAMETER | | TEST CONDITIONS | MIN | TYP | MAX | UNIT |
|---|--|--|------|------|------|---------|
| AVDD | | | | | | |
| V_{A_BYP} | A_BYP pin voltage | | | 6.5 | | V |
| $V_{A_BYP_UV_SET}$ | A_BYP UV voltage | | | 4.8 | | V |
| $V_{A_BYP_UV_CLEAR}$ | Recovery voltage A_BYP UV | | | 5.3 | | V |
| DVDD | | | | | | |
| V_{D_BYP} | D_BYP pin voltage | | | 3.3 | | V |
| POWER-ON RESET (POR) | | | | | | |
| V_{POR} | Maximum PVDD voltage for POR; I ² C active above this voltage | | | | 6 | V |
| V_{POR_HY} | PVDD recovery hysteresis voltage for POR | | | 0.1 | | V |
| REXT | | | | | | |
| V_{REXT} | Rext pin voltage | | | 1.24 | | V |
| CHARGE PUMP (CP) | | | | | | |
| V_{CPUV_SET} | CP undervoltage | | | 4.8 | | V |
| V_{CPUV_CLEAR} | Recovery voltage for CP UV | | | 5.2 | | V |
| OVERTEMPERATURE (OV) PROTECTION | | | | | | |
| T_{OTW1_CLEAR} | Junction temperature for overtemperature warning | | 102 | 115 | 128 | °C |
| $T_{OTW1_SET} / T_{OTW2_CLEAR}$ | | | 112 | 125 | 138 | |
| $T_{OTW2_SET} / T_{OTW3_CLEAR}$ | | | 122 | 135 | 148 | |
| $T_{OTW3_SET} / T_{OTWD_CLEAR}$ | | | 132 | 145 | 158 | |
| T_{OTSD} | Junction temperature for overtemperature shutdown | | 142 | 155 | 168 | |
| CURRENT LIMITING PROTECTION | | | | | | |
| I_{LIM1} | Current limit 1 (load current) | Load < 4 Ω | 5.5 | 7.3 | 9 | A |
| I_{LIM2} | Current limit 2 (load current), I ² C setting current limit level 2 | Load < 2 Ω | 8.5 | 11 | 13.5 | A |
| OVERCURRENT (OC) SHUTDOWN PROTECTION | | | | | | |
| I_{MAX1} | Maximum current 1 (peak output current) | Any short to supply, ground, or other channels | 9.5 | 11.3 | 13 | A |
| I_{MAX2} | Maximum current 2 (peak output current) | | 11.5 | 14.3 | 17 | A |
| TWEETER DETECT | | | | | | |
| I_{TH_TW} | Load current threshold for tweeter detect | | 325 | 540 | 750 | mA |
| I_{LIM_TW} | Load current limit for tweeter detect | | | 2 | | A |
| STANDBY MODE | | | | | | |
| V_{IH_STBY} | STANDBY input voltage for logic-level high | | 2 | | 5.5 | V |
| V_{IL_STBY} | STANDBY input voltage for logic-level low | | 0 | | 0.7 | V |
| I_{STBY_PIN} | STANDBY pin current | | | 0.1 | 0.2 | μA |
| MUTE MODE | | | | | | |
| G_{MUTE} | Output attenuation | MUTE pin $\leq 0.9V_{dc}$, $V_{IN} = 1 V_{rms}$ on all inputs | | 85 | | dB |
| DC DETECT | | | | | | |
| $V_{TH_DCD_POS}$ | DC detect positive threshold default value | PVDD = 14.4 Vdc, register 0x0E = 8EH | | 6.5 | | V |
| $V_{TH_DCD_NEG}$ | DC detect negative threshold default value | PVDD = 14.4 Vdc, register 0x0F = 3DH | | -6.5 | | V |
| t_{DCD} | DC detect step response time for four channels | | | | 4.3 | s |
| CLIP_OTW REPORT | | | | | | |
| $V_{OH_CLIPOTW}$ | CLIP_OTW pin output voltage for logic level high (open-drain logic output) | External 47-k Ω pullup resistor to 3 V–5.5 V | | 2.4 | | V |
| $V_{OL_CLIPOTW}$ | CLIP_OTW pin output voltage for logic level low (open-drain logic output) | | | | 0.5 | |

ELECTRICAL CHARACTERISTICS (continued)

Test conditions (unless otherwise noted): $T_{Case} = 25^{\circ}C$, $PVDD = 14.4 V$, $R_L = 4 \Omega$, $f_S = 417 kHz$, $R_{ext} = 20 k\Omega$, master mode operation (see application diagram)

| PARAMETER | | TEST CONDITIONS | MIN | TYP | MAX | UNIT |
|---------------------------------------|---|--|------|------|------|--------------|
| $t_{DELAY_CLIPDET}$ | CLIP_OTW signal delay when output clipping detected | | | | 20 | μs |
| FAULT REPORT | | | | | | |
| V_{OH_FAULT} | FAULT pin output voltage for logic-level high (open-drain logic output) | External 47-k Ω pullup resistor to 3 V–5.5 V | 2.4 | | | V |
| V_{OL_FAULT} | FAULT pin output voltage for logic-level low (open-drain logic output) | | 0.5 | | | |
| OPEN/SHORT DIAGNOSTICS | | | | | | |
| R_{S2P}, R_{S2G} | Maximum resistance to detect a short from OUT pin(s) to PVDD or ground | | 200 | | | Ω |
| R_{OPEN_LOAD} | Minimum load resistance to detect open circuit | Including speaker wires | 300 | 800 | 1300 | Ω |
| $R_{SHORTED_LOAD}$ | Maximum load resistance to detect short circuit | Including speaker wires | 0.5 | 1 | 1.5 | Ω |
| I²C ADDRESS DECODER | | | | | | |
| $t_{LATCH_I2CADDR}$ | Time delay to latch I ² C address after POR | | 300 | | | μs |
| V_{I2C_ADDR} | Voltage on I2C_ADDR pin for address 0 | Connect to SGND | 0% | 0% | 15% | V_{D_BYP} |
| | Voltage on I2C_ADDR pin for address 1 | External resistors in series between D_BYP and SGND as a voltage divider | 25% | 35% | 45% | |
| | Voltage on I2C_ADDR pin for address 2 | | 55% | 65% | 75% | |
| | Voltage on I2C_ADDR pin for address 3 | Connect to D_BYP | 85% | 100% | 100% | |
| I²C | | | | | | |
| t_{HOLD_I2C} | Power-on hold time before I ² C communication | STANDBY high | 1 | | | ms |
| f_{SCL} | SCL clock frequency | | 100 | | | kHz |
| V_{IH_SCL} | SCL pin input voltage for logic-level high | $R_{PU_I2C} = 5\text{-k}\Omega$ pullup, supply voltage = 3.3 V or 5 V | 2.1 | | | V |
| V_{IL_SCL} | SCL pin input voltage for logic-level low | | –0.5 | | | V |
| V_{OH_SDA} | SDA pin output voltage for logic-level high | I ² C read, $R_{I2C} = 5\text{-k}\Omega$ pullup, supply voltage = 3.3 V or 5 V | 2.4 | | | V |
| V_{OL_SDA} | SDA pin output voltage for logic-level low | I ² C read, 3-mA sink current | 0 | | | V |
| V_{IH_SDA} | SDA pin input voltage for logic-level high | I ² C write, $R_{I2C} = 5\text{-k}\Omega$ pullup, supply voltage = 3.3 V or 5 V | 2.1 | | | V |
| V_{IL_SDA} | SDA pin input voltage for logic-level low | I ² C write, $R_{I2C} = 5\text{-k}\Omega$ pullup, supply voltage = 3.3 V or 5 V | –0.5 | | | V |
| C_i | Capacitance for SCL and SDA pins | | 10 | | | pF |
| OSCILLATOR | | | | | | |
| $V_{OH_OSCSYNC}$ | OSC_SYNC pin output voltage for logic-level high | I2C_ADDR pin set to MASTER mode | 2.4 | | | V |
| $V_{OL_OSCSYNC}$ | OSC_SYNC pin output voltage for logic-level low | | 0.5 | | | |
| $V_{IH_OSCSYNC}$ | OSC_SYNC pin input voltage for logic-level high | I2C_ADDR pin set to SLAVE mode | 2 | | | V |
| $V_{IL_OSCSYNC}$ | OSC_SYNC pin input voltage for logic-level low | | 0.8 | | | |
| f_{OSC_SYNC} | OSC_SYNC pin clock frequency | I2C_ADDR pin set to MASTER mode, $f_S = 500 kHz$, maximum capacitive loading = 5 pF | 3.76 | 4.0 | 4.24 | MHz |
| | | I2C_ADDR pin set to MASTER mode, $f_S = 417 kHz$, maximum capacitive loading = 5 pF | 3.13 | 3.33 | 3.63 | |
| | | I2C_ADDR pin set to MASTER mode, $f_S = 357 kHz$, maximum capacitive loading = 5 pF | 2.68 | 2.85 | 3.0 | |

TIMING REQUIREMENTS FOR I²C INTERFACE SIGNALS

over recommended operating conditions (unless otherwise noted)

| PARAMETER | | MIN | TYP | MAX | UNIT |
|-------------|--|------------------|-----|------|---------|
| t_r | Rise time for both SDA and SCL signals | | | 1000 | ns |
| t_f | Fall time for both SDA and SCL signals | | | 300 | ns |
| $t_{w(H)}$ | SCL pulse duration, high | 4 | | | μ s |
| $t_{w(L)}$ | SCL pulse duration, low | 4.7 | | | μ s |
| t_{su2} | Setup time for START condition | 4.7 | | | μ s |
| t_{h2} | START condition hold time after which first clock pulse is generated | 4 | | | μ s |
| t_{su1} | Data setup time | 250 | | | ns |
| t_{h1} | Data hold time | 0 ⁽¹⁾ | | | ns |
| t_{su3} | Setup time for STOP condition | 4 | | | μ s |
| $t_{(buf)}$ | Time between a STOP and START condition | 4.7 | | | μ s |
| C_B | Load capacitance for each bus line | | | 400 | pF |

- (1) A device must internally provide a hold time of at least 300 ns for the SDA signal to bridge the undefined region of the falling edge of SCL.

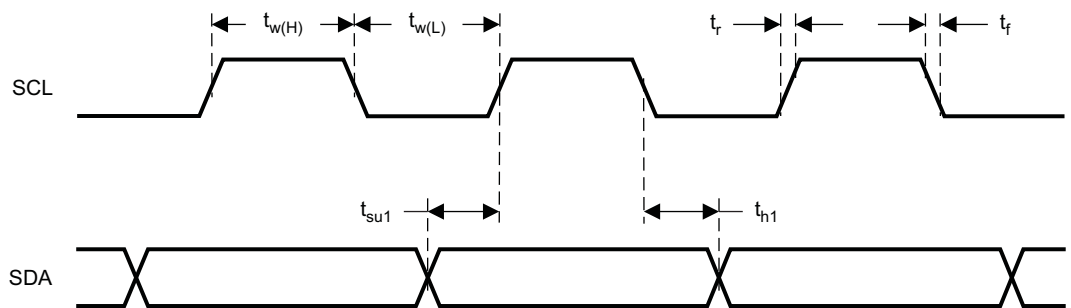

T0027-01

Figure 1. SCL and SDA Timing

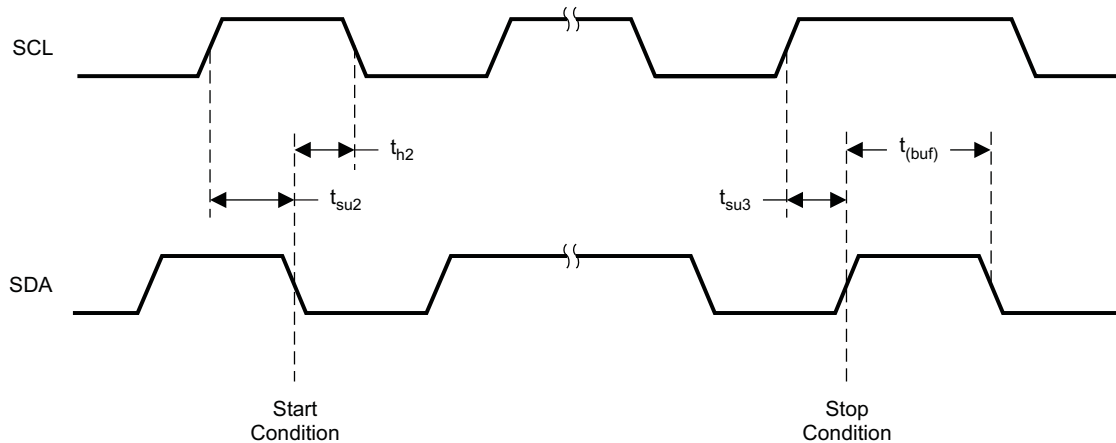

T0028-01

Figure 2. Timing for Start and Stop Conditions

TYPICAL CHARACTERISTICS

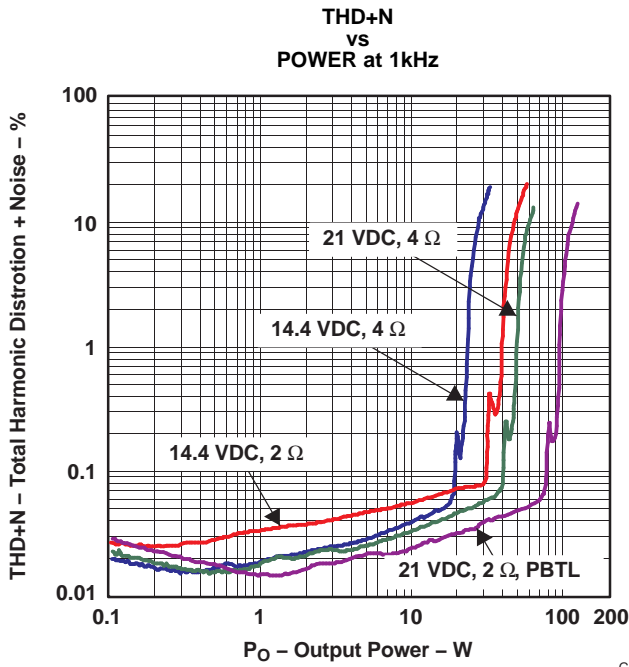

Figure 3.

G001

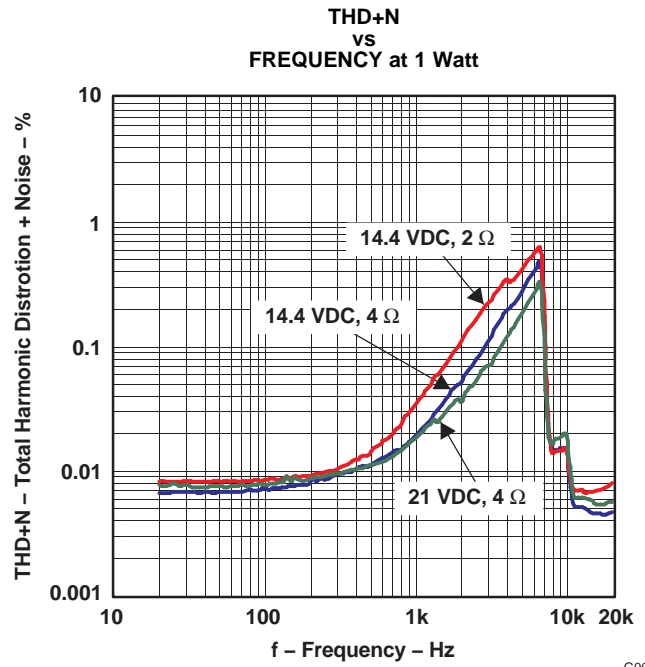

Figure 4.

G002

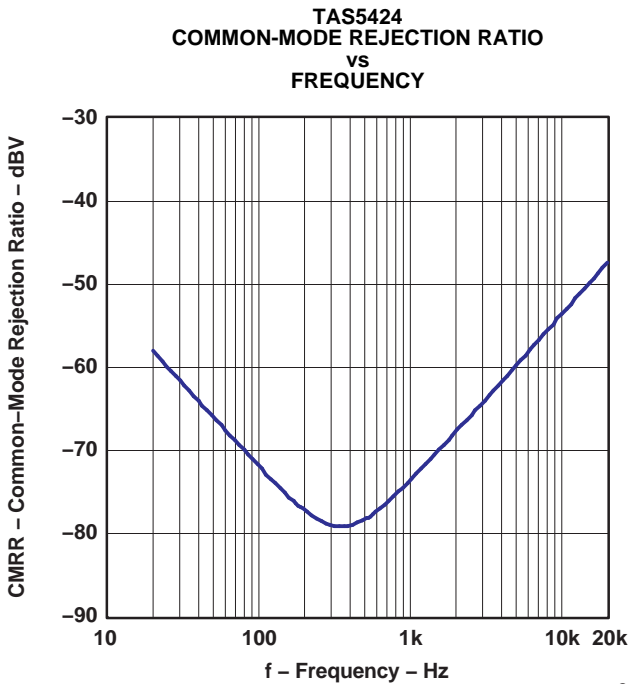

Figure 5.

G003

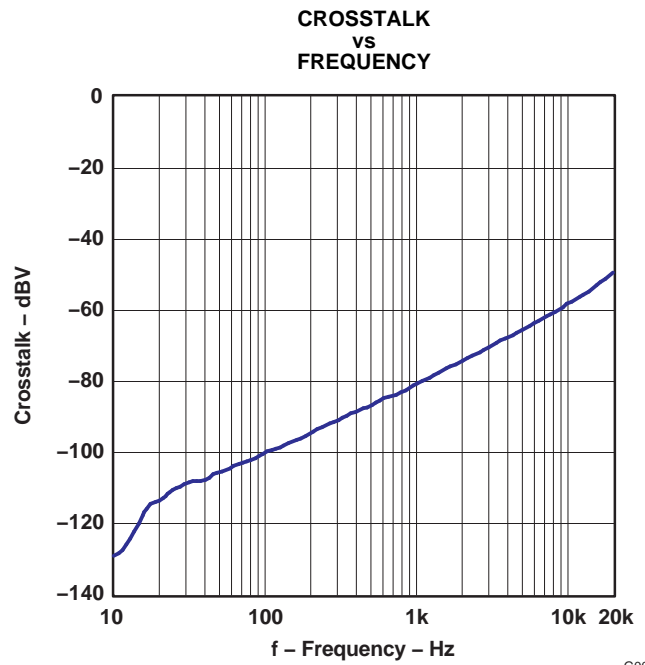

Figure 6.

G004

TYPICAL CHARACTERISTICS (continued)

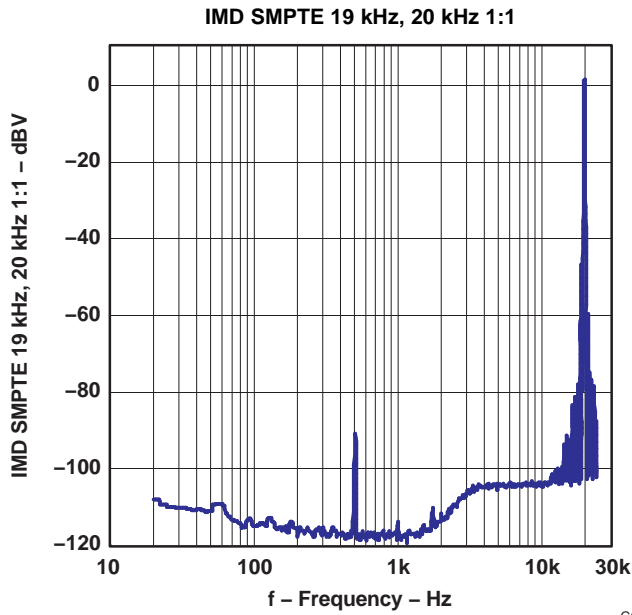

Figure 7.

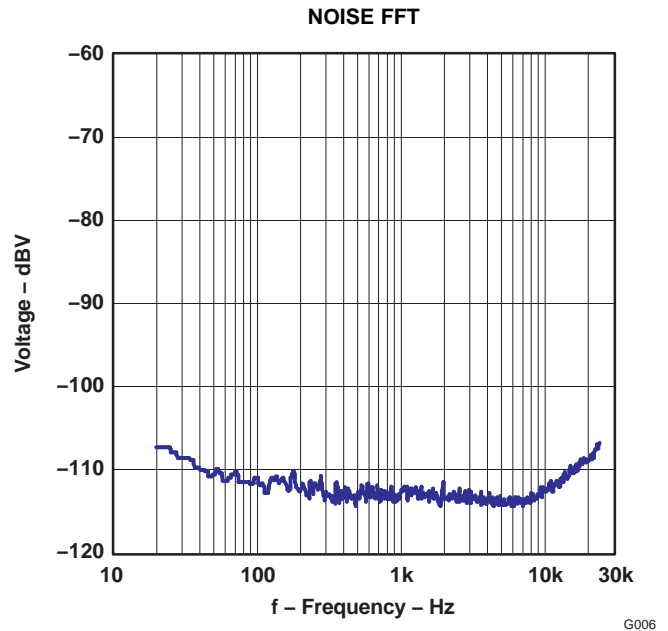

Figure 8.

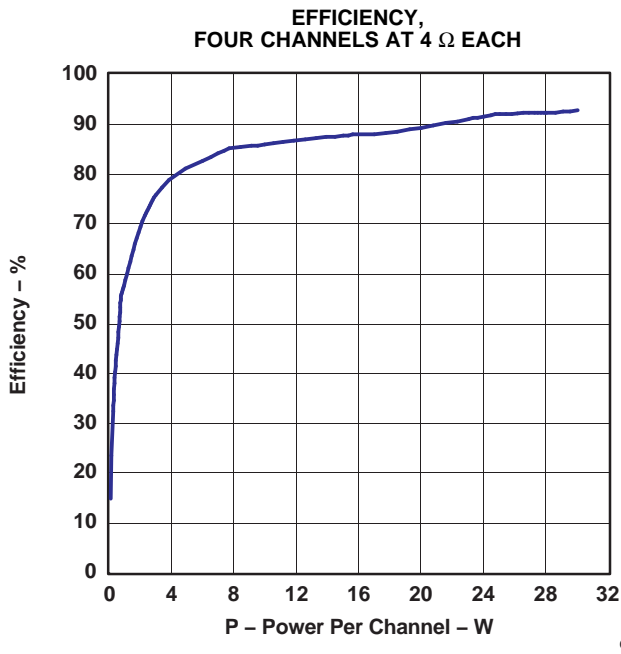

Figure 9.

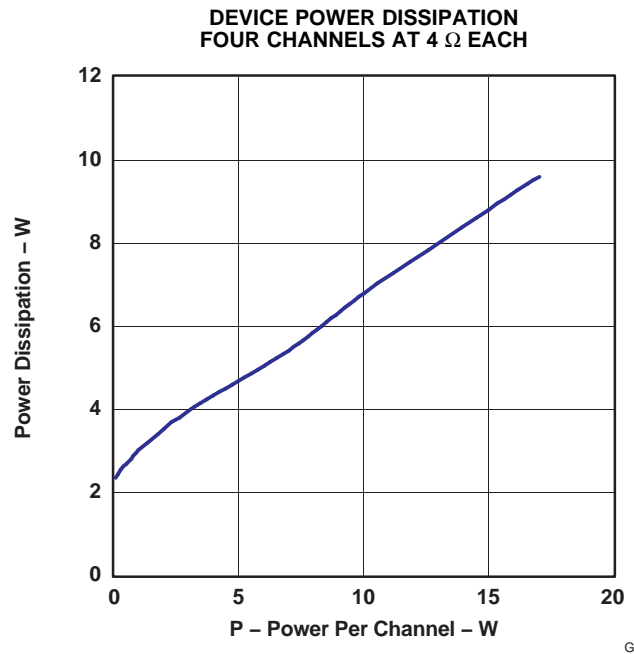

Figure 10.

TYPICAL CHARACTERISTICS (continued)

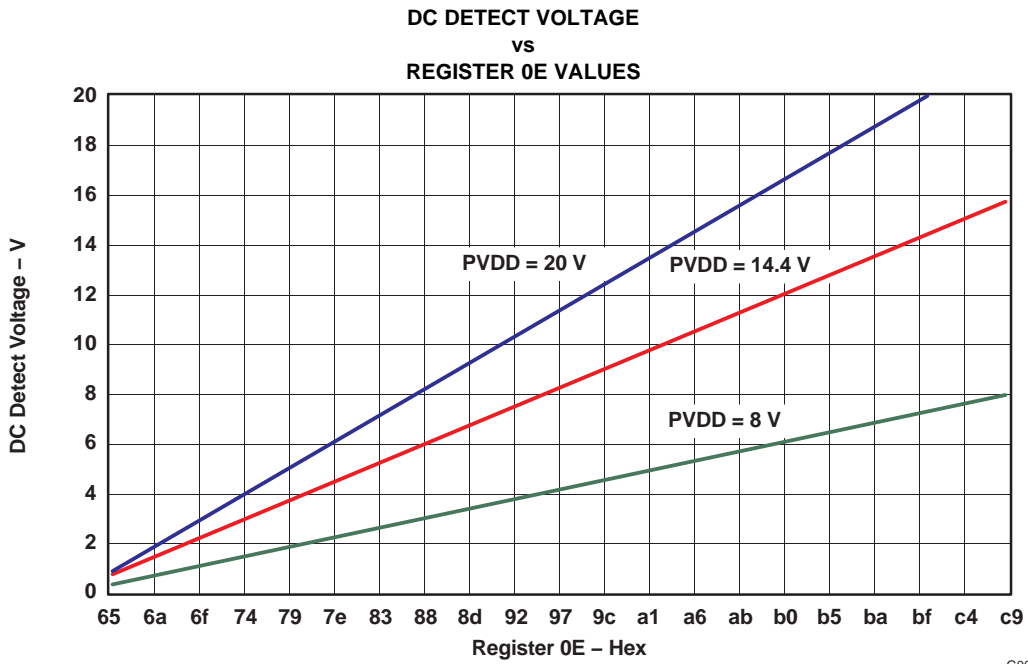

Figure 11.

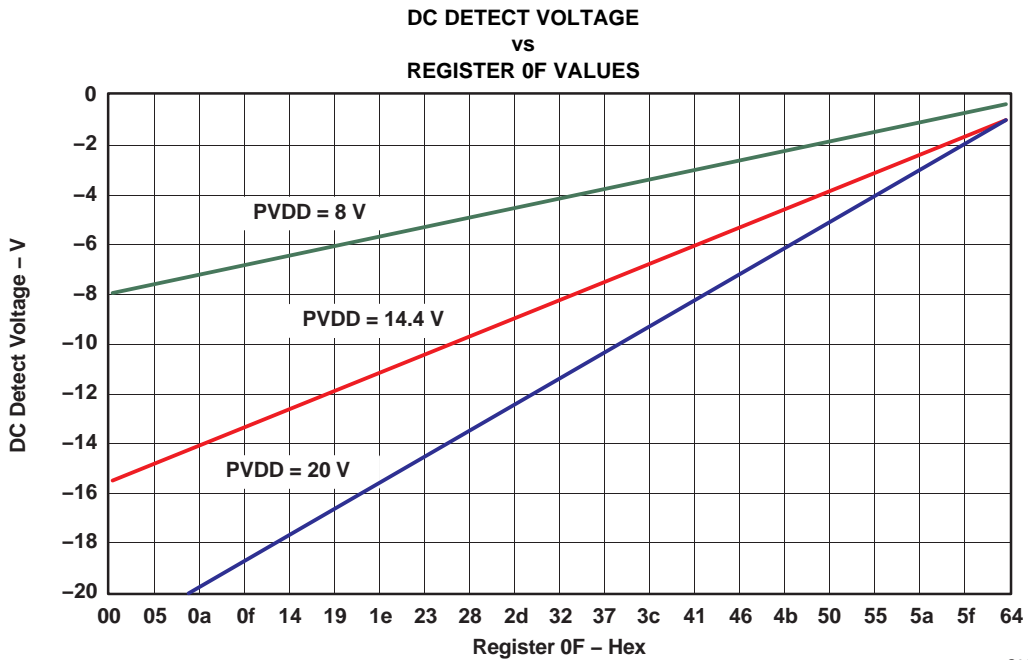

Figure 12.

DESCRIPTION OF OPERATION

OVERVIEW

The TAS5414 and TAS5424 are single-chip, four-channel, analog-input audio amplifiers for use in the automotive environment. The design uses an ultra-efficient class-D technology developed by Texas Instruments, but with changes needed by the automotive industry. This technology allows for reduced power consumption, reduced heat, and reduced peak currents in the electrical system. The TAS5414 and TAS5424 realize an audio sound system design with smaller size and lower weight than traditional class-AB solutions.

The TAS5414 and TAS5424 are composed of eight elements:

- Preamplifier
- PWM
- Gate drive
- Power FETs
- Diagnostics
- Protection
- Power supply
- I²C serial communication bus

Preamplifier

The preamplifier of the TAS5414 and TAS5424 is a high-input-impedance, low-noise, low-offset-voltage input stage with adjustable gain. The high input impedance of the TAS5414 and TAS5424 allows the use of low-cost 1- μ F input capacitors while still achieving extended low-frequency response. The preamplifier is powered by a dedicated, internally regulated supply, which gives it excellent noise immunity and channel separation. Also included in the preamp are:

1. **Mute Pop-and-Click Control**—An audio input signal is reshaped and amplified as a step when a mute is applied at the crest or trough of the signal. Such a step is perceived as a loud click. This is avoided in the TAS5414 and TAS5424 by ramping the gain gradually when a mute or play command is received. Another form of click and pop can be caused by the start or stopping of switching in a class-D amplifier. The TAS5414 and TAS5424 incorporate a patented method to reduce the pop energy during the switching startup and shutdown sequence. Fault conditions require rapid protection response by the TAS5414 and the TAS5424, which do not have time to ramp the gain down in a pop-free manner. The device transitions into Hi-Z mode when an OV, UV, OC, OT, or DC fault is encountered. Also, activation of the STANDBY pin may not be pop-free.
2. **Gain Control**—The four gain settings are set in the preamplifier via I²C control registers. The gain is set outside of the global feedback resistors of the TAS5414 and the TAS5424, thus allowing for stability in the system under all load conditions and gain settings.
3. **DC Offset Reduction Circuitry**—Circuitry has been incorporated to reduce the dc offset. DC offset in high-gain amplifiers can produce audible clicks and pops when the amplifier is started or stopped. The offset reduction circuitry can be disabled or enabled via I²C.

Pulse-Width Modulator (PWM)

The PWM converts the analog signal from the preamplifier into a switched signal of varying duty cycle. This is the critical stage that defines the class-D architecture. In the TAS5414 and TAS5424, the modulator is an advanced design with high bandwidth, low noise, low distortion, excellent stability, and full 0–100% modulation capability. The patented PWM uses clipping recovery circuitry to eliminate the deep saturation characteristic of PWMs when the input signal exceeds the modulator waveform.

Gate Drive

The gate driver accepts the low-voltage PWM signal and level shifts it to drive a high-current, full-bridge, power FET stage. The TAS5414 and TAS5424 use patent-pending techniques to avoid shoot-through and are optimized for EMI and audio performance.

DESCRIPTION OF OPERATION (continued)

Power FETs

The BTL output for each channel comprises four rugged N-channel 30-V FETs, each of which has an R_{DSon} of 75 m Ω for high efficiency and maximum power transfer to the load. These FETs are designed to handle large voltage transients during load dump.

Load Diagnostics

The TAS5414 and TAS5424 incorporate load diagnostic circuitry designed to help pinpoint the nature of output misconnections during installation. The TAS5414 and the TAS5424 include functions for detecting and determining the status of output connections. The following diagnostics are supported:

- Short to GND
- Short to PVDD
- Short across load ($R < 1 \Omega$, typical)
- Open load ($R > 800 \Omega$, typical)
- Tweeter detection

The presence of any of the short or open conditions is reported to the system via I²C register read. The tweeter detect status can be read from the $\overline{CLIP_OTW}$ pin when properly configured.

1. **Output Short and Open Diagnostics**—The TAS5414 and TAS5424 contain circuitry designed to detect shorts and open conditions on the outputs. The load diagnostic function can only be invoked when the output is in the Hi-Z mode. There are four phases of test during load diagnostics and two levels of test. In the full level, all channels must be in the Hi-Z state. All four phases are tested on each channel, all four channels at the same time. When fewer than four channels are in Hi-Z, the reduced level of test is the only available option. In the reduced level, only short to PVDD and short to GND can be tested. Load diagnostics can occur at power up before the amplifier is moved out of Hi-Z mode. If the amplifier is already in play mode, it must *Mute* and then *Hi-Z* before the load diagnostic can be performed. By performing the mute function, the normal pop- and click-free transitions occur before the diagnostics begin. The diagnostics are performed as shown in Figure 13. Figure 14 shows the impedance ranges for the open-load and shorted-load diagnostics. The results of the diagnostic are read from the diagnostic register for each channel via I²C. **Note:** Do not send a command via I²C to register 0x0C during the load diagnostic test.

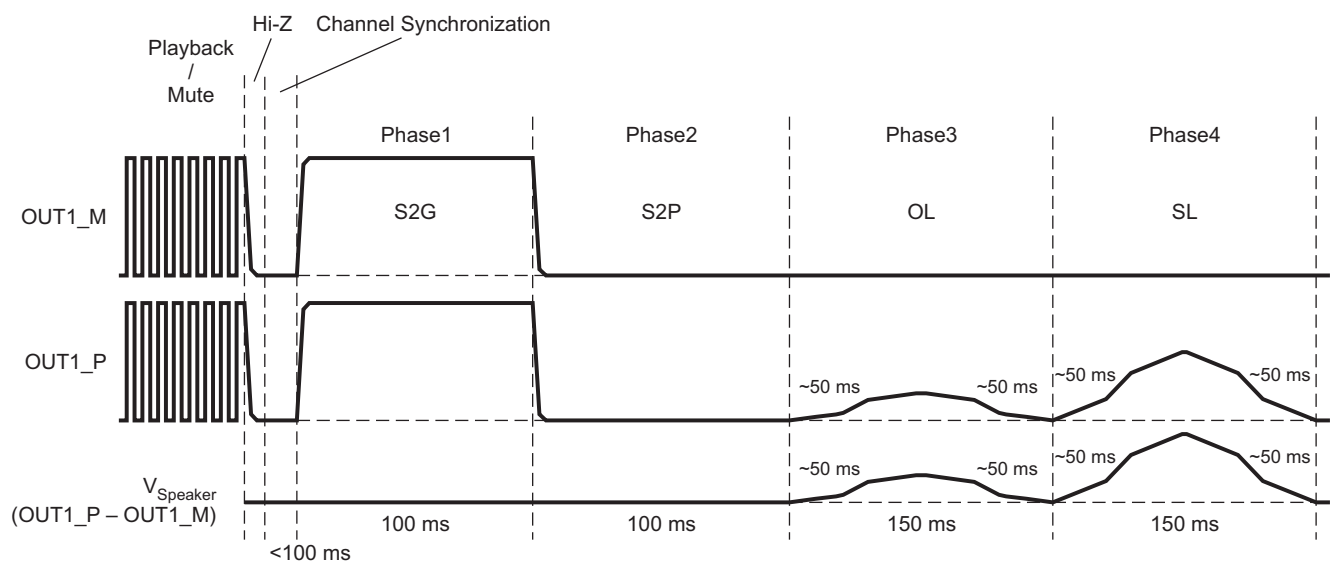

T0188-01

Figure 13. Load Diagnostics Sequence of Events

DESCRIPTION OF OPERATION (continued)

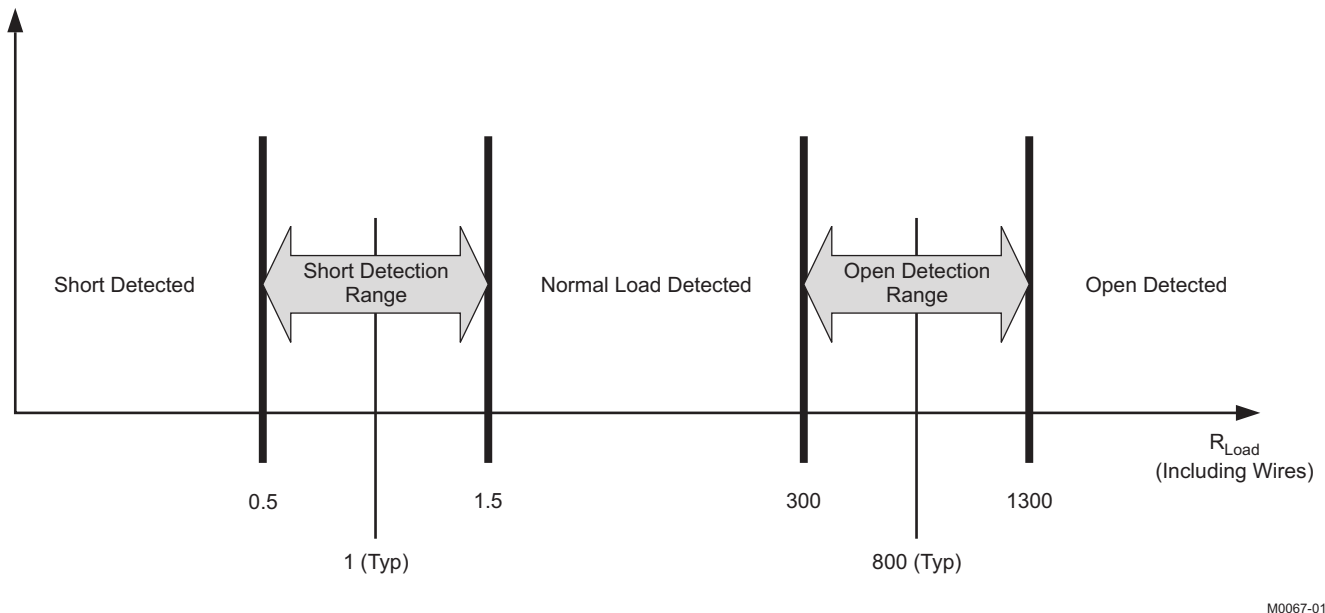

M0067-01

Figure 14. Open and Shorted Load Detection

- 2. Tweeter Detection**—The tweeter detection function is an ac diagnostic used to determine proper connection of the tweeter when a passive crossover is used. The proper implementation of this diagnostic function is dependent on the amplitude of a user-supplied test signal and on the impedance vs frequency curve of the acoustic package. The tweeter function is invoked via I²C, and all four channels should be tested individually. The tweeter detection uses the average cycle-by-cycle current limit circuit (see [CBC](#) section) to measure the current to the load. The current level for the tweeter detection threshold is typically 550 mA. The system (external to the TAS5414 and TAS5424) must generate a tone burst in the 10-kHz to 25-kHz range. If the tone burst employs a frequency higher than 20 kHz, and if a sufficiently smooth amplitude ramp is used, the tweeter detection signal is silent. The frequency and amplitude of this tone burst must be calibrated by the user to result in a current draw greater than the selected threshold level when the tweeter is present. The tweeter detection results are monitored on the CLIP_OTW pin during the application of the test tone. If the current threshold is attained during measurement, the tweeter is present; then the CLIP_OTW pin is asserted. When the tweeter detector is activated, pulses on the CLIP_OTW pin begin to toggle at 250 kHz to 500 kHz. As the detection signal gets stronger due to higher load current, the density (or duty cycle) of the pulses increases.

Protection and Monitoring

- 1. Cycle-By-Cycle Current Limit (CBC)**—The CBC current-limiting circuit terminates each PWM pulse to limit the output current flow when the average current limit (I_{LIM}) threshold is exceeded. The overall effect on the audio in the case of a current overload is quite similar to a voltage-clipping event, where power is temporarily limited at the peaks of the musical signal and normal operation continues without disruption when the overload is removed. The TAS5414 and TAS5424 do not prematurely shut down in this condition. All four channels continue in play mode and pass signal.
- 2. Overcurrent Shutdown (OCS)**—Under severe short-circuit events, such as a short to PVDD or ground, a peak-current detector is used, and the affected channel shuts down in 200 μ s to 390 μ s if the conditions are severe enough. The shutdown speed depends on a number of factors, such as the impedance of the short circuit, supply voltage, and switching frequency. Only the shorted channels are shut down in such a scenario. The user may restart the affected channel via I²C. An OCS event activates the fault pin, and the affected channel(s) are recorded in the I²C fault register. If the supply or ground short is strong enough to exceed the peak current threshold but not severe enough to trigger the OCS, the peak current limiter prevents excess current from damaging the output FETs, and operation returns to normal after the short is removed.
- 3. DC Detect**—This circuit detects a dc offset continuously during normal operation at the output of the

DESCRIPTION OF OPERATION (continued)

amplifier. If the dc offset reaches the level defined in the I²C registers for the specified time period, the circuit triggers. By default a dc detection event does not shut the output down. The shutdown function can be enabled or disabled via I²C. If enabled, the triggered channel shuts down, but the others remain playing and the FAULT pin is asserted. The positive dc level and negative dc level are defined in I²C registers and can have separate thresholds.

4. **Clip Detect**—The clip detect circuit alerts the user to the presence of a 100% duty-cycle PWM due to a clipped waveform. When this occurs, a signal is passed to the CLIP_OTW pin and it is asserted until the 100% duty-cycle PWM signal is no longer present. All four channels are connected to the same CLIP_OTW pin. Through I²C, the CLIP_OTW signal can be changed to clip-only, OTW-only, or both. A fourth mode, used only during diagnostics, is the option to report tweeter detection events on this pin (see the [Tweeter Detection](#) section). The microcontroller in the system can monitor the signal at the CLIP_OTW pin and may be configured to reduce the volume to all four channels in an active clipping-prevention circuit.
5. **Overtemperature Warning (OTW) and Overtemperature Shutdown (OTSD)**—By default, the CLIP_OTW pin is set to indicate an OTW. This can be changed via I²C commands. If selected to indicate a temperature warning, the CLIP_OTW pin is asserted when the die temperature reaches 125°C. The OTW has three temperature thresholds with a 10°C hysteresis. Each threshold is indicated in I²C register 0x04 bits 5, 6, and 7. The TAS5414 and TAS5424 still function until the temperature reaches the OTSD threshold, 155°C, at which time the outputs are placed into Hi-Z mode and the FAULT pin is asserted. I²C is still active in the event of an OTSD and the registers can be read for faults, but all audio ceases abruptly. The OTSD resets at 145°C, to allow the TAS5414/5424 to be turned back on through I²C. The OTW is still indicated until the temperature drops below 115°C. All temperatures are nominal values.
6. **Undervoltage (UV) and Power-on-Reset (POR)**—The undervoltage (UV) protection detects low voltages on PVDD, AVDD, and CP. In the event of an undervoltage, the FAULT pin is asserted and the I²C register is updated, depending on which voltage caused the event. Power-on-reset (POR) occurs when PVDD drops low enough. A POR event causes the I²C to go into a high-impedance state. After the device recovers from the POR event, the device must be re-initialized via I²C.
7. **Overvoltage (OV) and Load Dump**—The OV protection detects high voltages on PVDD. If PVDD reaches the overvoltage threshold, the FAULT pin is asserted and the I²C register is updated. If the voltage increases beyond the load dump threshold of 29 Vdc, the device shuts down and must be restarted once the voltage returns to a safe value. After the device recovers from the ≈ load dump event, the device must be re-initialized via I²C. The TAS5414 and TAS5424 can withstand 50-V load-dump voltage spikes (see [Figure 15](#)). Also depicted in this graph are the voltage thresholds for normal operation region, overvoltage operation region, and load-dump protection region. [Figure 13](#) shows the regions of operating voltage and the profile of the load dump event. Battery charger voltages from 25 V to 35 V can be withstood for up to 1 hour.

DESCRIPTION OF OPERATION (continued)

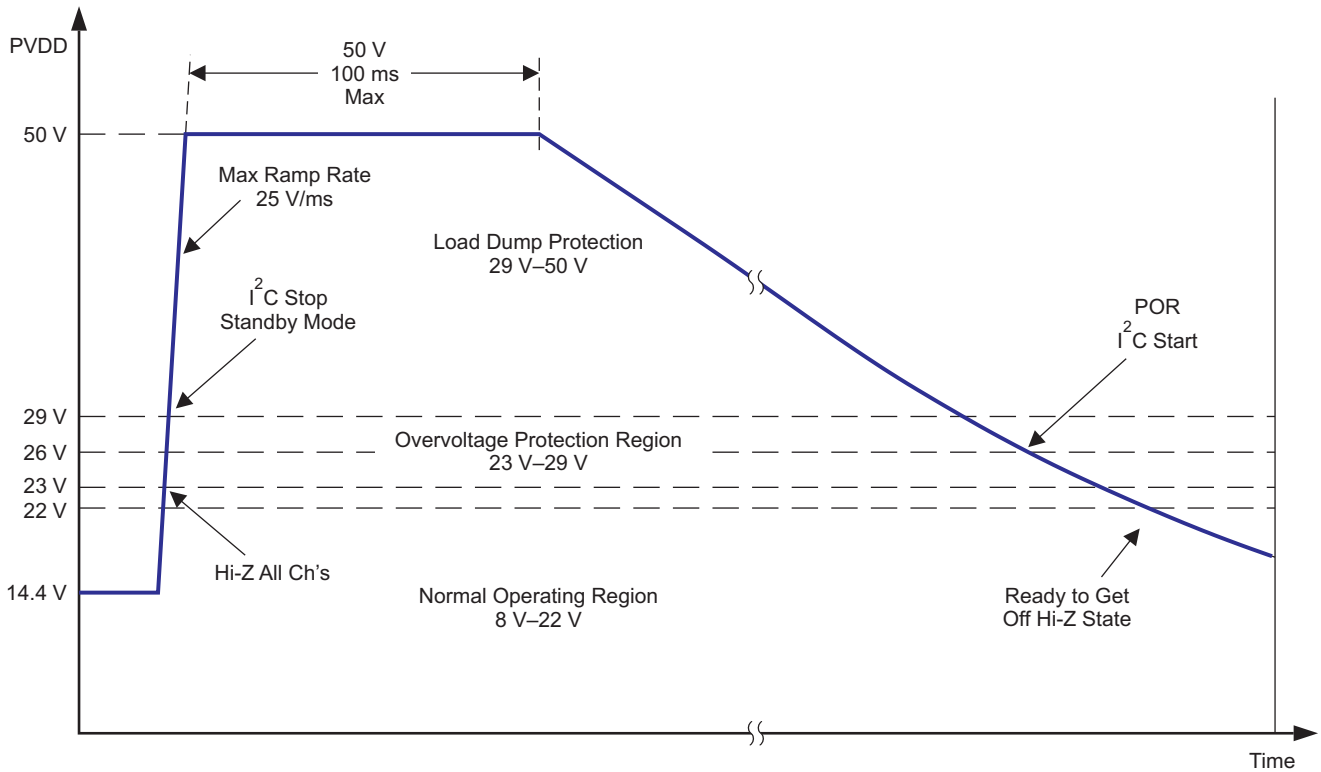

T0189-01

Figure 15. Voltage Operating Regions With Load Dump Transition Defined

Power Supply

The power for the device is most commonly provided by a car battery that can have a large voltage swing, 8 Vdc to 18 Vdc. PVDD is a filtered battery voltage, and it is the supply for the output FETS and the low-side FET gate driver. The high-side FET gate driver is supplied by a charge pump (CP) supply. The charge pump supplies the gate drive voltage for all four channels. The analog circuitry is powered by AVDD, which is provided by an internal linear regulator. A 0.1µF/10V external bypass capacitor is needed at the A_BYP pin for this supply. It is recommended that no external components except the bypass capacitor be attached to this pin. The digital circuitry is powered by DVDD, which is provided by an internal linear regulator. A 0.1µF/10V external bypass capacitor is needed at the D_BYP pin. It is recommended that no external components except the bypass capacitor be attached to this pin.

The TAS5414 and TAS5424 can withstand fortuitous open ground and power conditions. Fortuitous open ground usually occurs when a speaker wire is shorted to ground, allowing for a second ground path through the body diode in the output FETs. The uniqueness of the diagnostic capabilities allows the speakers and speaker wires to be debugged, eliminating the need to remove the amplifier to diagnose the problem.

I²C Serial Communication Bus

The TAS5414 and TAS5424 communicate with the system processor via the I²C serial communication bus. The TAS5414 and TAS5424 are I²C slave-only devices. The processor can poll the TAS5414 and the TAS5424 via I²C to determine the operating status of the device. All fault conditions and detections are reported via I²C. There are also numerous features and operating conditions that can be set via I²C.

The I²C bus allows control of the following configurations:

- Independent gain control of each channel. The gain can be set to 12 dB, 20 dB, 26 dB, and 32 dB.

DESCRIPTION OF OPERATION (continued)

- Select current limit (for 2-Ω and for 4-Ω loads). This allows optimal design of the filter inductor, and the use of smaller gauge speaker wires for 4-Ω applications.
- Select AM non-interference switching frequency
- Select the function of OTW_CLIP pin
- Enable or disable dc detect function with selectable threshold
- Place channel in Hi-Z (switching stopped) mode (mute)
- Select tweeter detect, set detect threshold and initiate function
- Initiate open/short load diagnostic
- Reset faults and return to normal switching operation from Hi-Z mode (unmute)

In addition to the standard SDA and SCL pins for the I²C bus, the TAS5414 and the TAS5424 include a single pin that allows up to four devices to work together in a system with no additional hardware required for communication or synchronization. The I2C_ADDR pin sets the device in master or slave mode and selects the I²C address for that device. Tie I2C_ADDR to DGND for master, to 1.2 Vdc for slave 1, to 2.4 Vdc for slave 2, and to D_BYN for slave 3. The OSC_SYNC pin is used to synchronize the internal clock oscillators and thereby avoid beat frequencies. An external oscillator can also be applied to this pin for external control of the switching frequency.

Table 2. Table 7. I2C_ADDR Pin Connection

| DESCRIPTION | I2C_ADDR PIN CONNECTION | I ² C ADDRESS |
|-----------------------------|--|--------------------------|
| TAS5414/5424 0 (OSC MASTER) | To SGND pin | 0xD8/D9 |
| TAS5414/5424 1 (OSC SLAVE1) | 35% DVDD (resistive voltage divider between D_BYN pin and SGND pin) ⁽¹⁾ | 0xDA/DB |
| TAS5414/5424 2 (OSC SLAVE2) | 65% DVDD (resistive voltage divider between D_BYN pin and SGND pin) ⁽¹⁾ | 0xDC/DD |
| TAS5414/5424 3 (OSC SLAVE3) | To D_BYN pin | 0xDE/DF |

(1) R_{I2C_ADDR} with 5% or better tolerance is recommended.

I²C Bus Protocol

The TAS5414 and TAS5424 have a bidirectional serial control interface that is compatible with the Inter IC (I²C) bus protocol and supports 100-kbps data transfer rates for random and sequential write and read operations. This is a slave-only device that does not support a multimaster bus environment or wait state insertion. The control interface is used to program the registers of the device and to read device status.

The I²C bus employs two signals, SDA (data) and SCL (clock), to communicate between integrated circuits in a system. Data is transferred on the bus serially, one bit at a time. The address and data are transferred in byte (8-bit) format with the most-significant bit (MSB) transferred first. In addition, each byte transferred on the bus is acknowledged by the receiving device with an acknowledge bit. Each transfer operation begins with the master device driving a start condition on the bus and ends with the master device driving a stop condition on the bus. The bus uses transitions on the data terminal (SDA) while the clock is HIGH to indicate a start and stop conditions. A HIGH-to-LOW transition on SDA indicates a start, and a LOW-to-HIGH transition indicates a stop. Normal data bit transitions must occur within the low time of the clock period. These conditions are shown in [Figure 16](#). The master generates the 7-bit slave address and the read/write (R/W) bit to open communication with another device and then wait for an acknowledge condition. The TAS5414 and TAS5424 hold SDA LOW during the acknowledge-clock period to indicate an acknowledgement. When this occurs, the master transmits the next byte of the sequence. Each device is addressed by a unique 7-bit slave address plus R/W bit (1 byte). All compatible devices share the same signals via a bidirectional bus using a wired-AND connection. An external pullup resistor must be used for the SDA and SCL signals to set the HIGH level for the bus. There is no limit on the number of bytes that can be transmitted between start and stop conditions. When the last word transfers, the master generates a stop condition to release the bus.

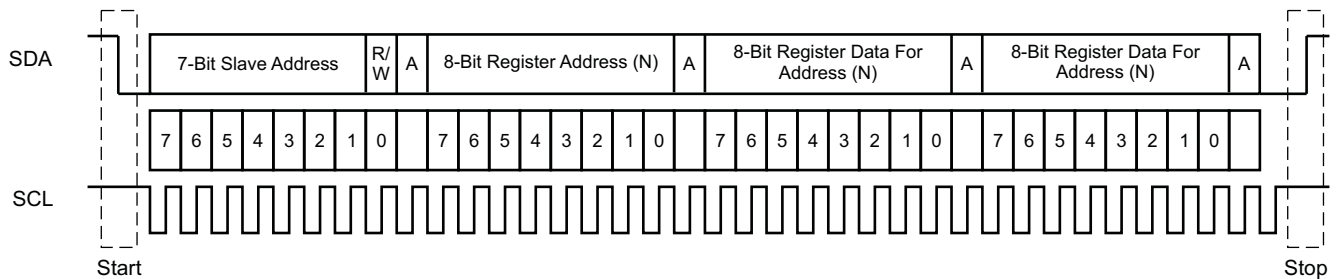

T0035-01

Figure 16. Typical I²C Sequence

Use the I2C_ADDR pin (pin 2) to program the device for one of four addresses. These four addresses are licensed I²C addresses and do not conflict with other licensed I²C audio devices. To communicate with the TAS5414 and the TAS5424, the I²C master uses addresses shown in Figure 16. Read and write data can be transmitted using single-byte or multiple-byte data transfers.

Random Write

As shown in Figure 17, a single-byte data-write transfer begins with the master device transmitting a start condition followed by the I²C device address and the read/write bit. The read/write bit determines the direction of the data transfer. For a write data transfer, the read/write bit is a 0. After receiving the correct I²C device address and the read/write bit, the TAS5414 or TAS5424 device responds with an acknowledge bit. Next, the master transmits the address byte or bytes corresponding to the internal memory address being accessed. After receiving the address byte, the TAS5414 or TAS5424 again responds with an acknowledge bit. Next, the master device transmits the data byte to be written to the memory address being accessed. After receiving the data byte, the TAS5414 or TAS5424 again responds with an acknowledge bit. Finally, the master device transmits a stop condition to complete the single-byte data-write transfer.

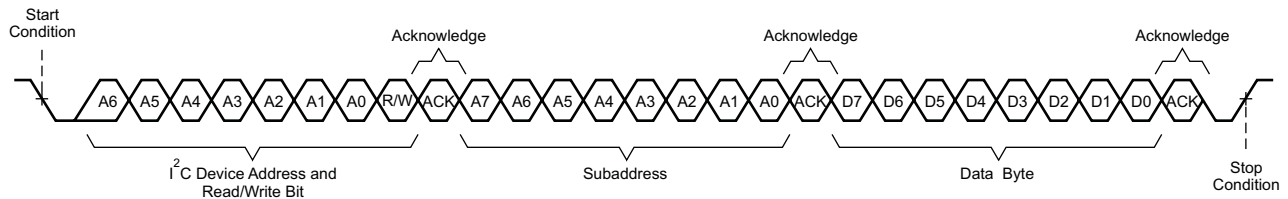

T0036-01

Figure 17. Random Write Transfer

Sequential Write

A sequential data-write transfer is identical to a single-byte data-write transfer except that multiple data bytes are transmitted by the master device to TAS5414 or TAS5424 as shown in Figure 17. After receiving each data byte, the TAS5414 or TAS5424 responds with an acknowledge bit and the I²C subaddress is automatically incremented by one.

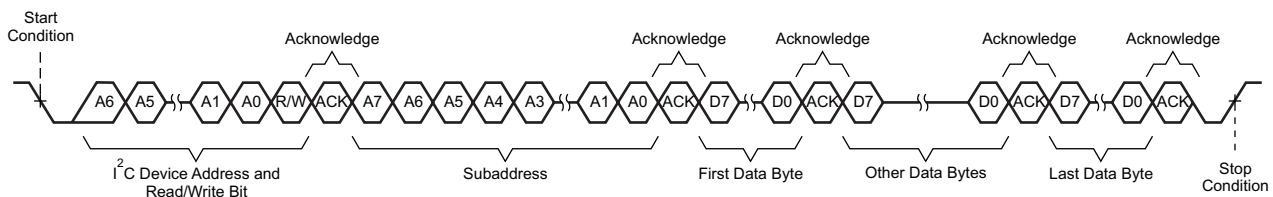

T0036-02

Figure 18. Sequential Write Transfer

Random Read

As shown in Figure 19, a single-byte data-read transfer begins with the master device transmitting a start condition followed by the I²C device address and the read/write bit. For the data-read transfer, both a write followed by a read are actually done. Initially, a write is done to transfer the address byte or bytes of the internal memory address to be read. As a result, the read/write bit is a 0. After receiving the address and the read/write bit, the TAS5414 or TAS5424 responds with an acknowledge bit. In addition, after sending the internal memory address byte or bytes, the master device transmits another start condition followed by the TAS5414 or TAS5424 address and the read/write bit again. This time the read/write bit is a 1, indicating a read transfer. After receiving the address and the read/write bit, the TAS5414 or TAS5424 again responds with an acknowledge bit. Next, the TAS5414 or TAS5424 transmits the data byte from the memory address being read. After receiving the data byte, the master device transmits a not-acknowledge followed by a stop condition to complete the single-byte data-read transfer.

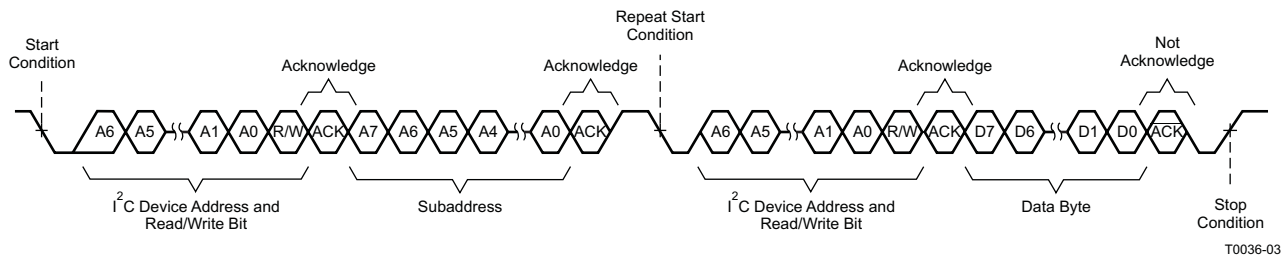

Figure 19. Random Read Transfer

Sequential Read

A sequential data-read transfer is identical to a single-byte data-read transfer except that multiple data bytes are transmitted by the TAS5414 or TAS5424 to the master device as shown in Figure 20. Except for the last data byte, the master device responds with an acknowledge bit after receiving each data byte and automatically increments the I²C subaddress by one. **Note:** The fault registers do not have sequential read capabilities.

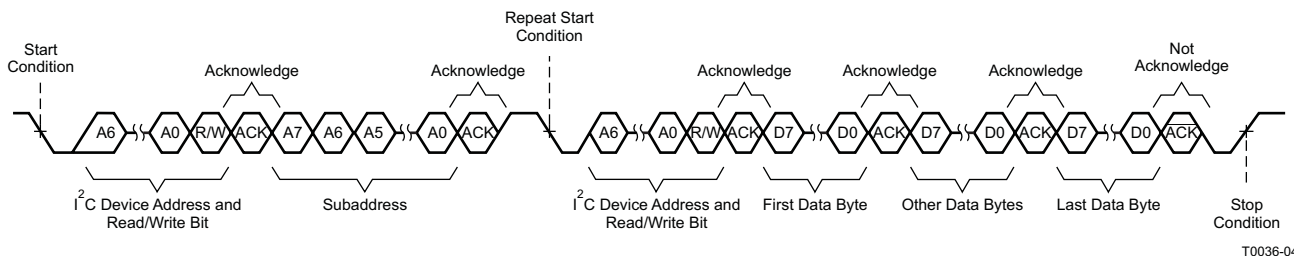

Figure 20. Sequential Read Transfer

Table 3. TAS5414/5424 I²C Addresses

| DESCRIPTION | | FIXED ADDRESS | | | | | SELECTABLE WITH ADDRESS PIN | | READ/WRITE BIT | I ² C ADDRESS |
|--------------------------------|------------------------|---------------|---|---|---|---|-----------------------------|---|----------------|--------------------------|
| | | MSB | 6 | 5 | 4 | 3 | 2 | 1 | LSB | |
| TAS5414/5424 0 (OSC MASTER) | I ² C WRITE | 1 | 1 | 0 | 1 | 1 | 0 | 0 | 0 | 0xD8 |
| | I ² C READ | 1 | 1 | 0 | 1 | 1 | 0 | 0 | 1 | 0xD9 |
| TAS5414/5424 1 (OSC SLAVE1) | I ² C WRITE | 1 | 1 | 0 | 1 | 1 | 0 | 1 | 0 | 0xDA |
| | I ² C READ | 1 | 1 | 0 | 1 | 1 | 0 | 1 | 1 | 0xDB |
| TAS5414/5424 2 (OSC SLAVE2) | I ² C WRITE | 1 | 1 | 0 | 1 | 1 | 1 | 0 | 0 | 0xDC |
| | I ² C READ | 1 | 1 | 0 | 1 | 1 | 1 | 0 | 1 | 0xDD |
| TAS5414/5424 3 (OSC SLAVE3) | I ² C WRITE | 1 | 1 | 0 | 1 | 1 | 1 | 1 | 0 | 0xDE |
| | I ² C READ | 1 | 1 | 0 | 1 | 1 | 1 | 1 | 1 | 0xDF |

Table 4. I²C Address Register Definitions

| ADDRESS | R/W | REGISTER DESCRIPTION |
|---------|-----|---|
| 0x00 | R | Latched fault register 1, global and channel fault |
| 0x01 | R | Latched fault register 2, dc offset and overcurrent detect |
| 0x02 | R | Latched fault register 3, load diagnostics |
| 0x03 | R | Latched fault register 4, load diagnostics |
| 0x04 | R | External status register 1, temperature and voltage detect |
| 0x05 | R | External status register 2, Hi-Z and low-low state |
| 0x06 | R | External status register 3, mute and play modes |
| 0x07 | R | External status register 4, load diagnostics |
| 0x08 | R/W | External control register 1, channel gain select |
| 0x09 | R/W | External control register 2, dc offset reduction and current-limit select |
| 0x0A | R/W | External control register 3, switching frequency and clip pin select |
| 0x0B | R/W | External control register 4, load diagnostic, master mode select |
| 0x0C | R/W | External control register 5, output state control |
| 0x0D | R/W | External control register 6, output state control |
| 0x0E | R/W | External control register 7, dc detect level select |
| 0x0F | R/W | External control register 8, dc detect level select |

Table 5. Fault Register 1 (0x00) Protection

| D7 | D6 | D5 | D4 | D3 | D2 | D1 | D0 | FUNCTION |
|----|----|----|----|----|----|----|----|--|
| 0 | 0 | 0 | 0 | 0 | 0 | 0 | 0 | No protection-created faults, default value |
| – | – | – | – | – | – | – | 1 | Overtemperature warning has occurred |
| – | – | – | – | – | – | 1 | – | DC offset has occurred in any channel |
| – | – | – | – | – | 1 | – | – | Overcurrent shutdown has occurred in any channel |
| – | – | – | – | 1 | – | – | – | Overtemperature shutdown has occurred |
| – | – | – | 1 | – | – | – | – | Charge pump undervoltage has occurred |
| – | – | 1 | – | – | – | – | – | AVDD, analog voltage, undervoltage has occurred |
| – | 1 | – | – | – | – | – | – | PVDD undervoltage has occurred |
| 1 | – | – | – | – | – | – | – | PVDD overvoltage has occurred |

Table 6. Fault Register 2 (0x01) Protection

| D7 | D6 | D5 | D4 | D3 | D2 | D1 | D0 | FUNCTION |
|----|----|----|----|----|----|----|----|---|
| 0 | 0 | 0 | 0 | 0 | 0 | 0 | 0 | No protection-created faults, default value |
| – | – | – | – | – | – | – | 1 | Overcurrent shutdown channel 1 has occurred |
| – | – | – | – | – | – | 1 | – | Overcurrent shutdown channel 2 has occurred |

Table 6. Fault Register 2 (0x01) Protection (continued)

| D7 | D6 | D5 | D4 | D3 | D2 | D1 | D0 | FUNCTION |
|----|----|----|----|----|----|----|----|---|
| – | – | – | – | – | 1 | – | – | Overcurrent shutdown channel 3 has occurred |
| – | – | – | – | 1 | – | – | – | Overcurrent shutdown channel 4 has occurred |
| – | – | – | 1 | – | – | – | – | DC offset channel 1 has occurred |
| – | – | 1 | – | – | – | – | – | DC offset channel 2 has occurred |
| – | 1 | – | – | – | – | – | – | DC offset channel 3 has occurred |
| 1 | – | – | – | – | – | – | – | DC offset channel 4 has occurred |

Table 7. Fault Register 3 (0x02) Load Diagnostics

| D7 | D6 | D5 | D4 | D3 | D2 | D1 | D0 | FUNCTION |
|----|----|----|----|----|----|----|----|--|
| 0 | 0 | 0 | 0 | 0 | 0 | 0 | 0 | No load-diagnostic-created faults, default value |
| – | – | – | – | – | – | – | 1 | Output short to ground channel 1 has occurred |
| – | – | – | – | – | – | 1 | – | Output short to PVDD channel 1 has occurred |
| – | – | – | – | – | 1 | – | – | Shorted load channel 1 has occurred |
| – | – | – | – | 1 | – | – | – | Open load channel 1 has occurred |
| – | – | – | 1 | – | – | – | – | Output short to ground channel 2 has occurred |
| – | – | 1 | – | – | – | – | – | Output short to PVDD channel 2 has occurred |
| – | 1 | – | – | – | – | – | – | Shorted load channel 2 has occurred |
| 1 | – | – | – | – | – | – | – | Open load channel 2 has occurred |

Table 8. Fault Register 4 (0x03) Load Diagnostics

| D7 | D6 | D5 | D4 | D3 | D2 | D1 | D0 | FUNCTION |
|----|----|----|----|----|----|----|----|--|
| 0 | 0 | 0 | 0 | 0 | 0 | 0 | 0 | No load-diagnostic-created faults, default value |
| – | – | – | – | – | – | – | 1 | Output short to ground channel 3 has occurred |
| – | – | – | – | – | – | 1 | – | Output short to PVDD channel 3 has occurred |
| – | – | – | – | – | 1 | – | – | Shorted load channel 3 has occurred |
| – | – | – | – | 1 | – | – | – | Open load channel 3 has occurred |
| – | – | – | 1 | – | – | – | – | Output short to ground channel 4 has occurred |
| – | – | 1 | – | – | – | – | – | Output short to PVDD channel 4 has occurred |
| – | 1 | – | – | – | – | – | – | Shorted load channel 4 has occurred |
| 1 | – | – | – | – | – | – | – | Open load channel 4 has occurred |

Table 9. External Status Register 1 (0x04) Fault Detection

| D7 | D6 | D5 | D4 | D3 | D2 | D1 | D0 | FUNCTION |
|----|----|----|----|----|----|----|----|---|
| 0 | 0 | 0 | 0 | 0 | 0 | 0 | 0 | No protection-created faults are present, default value |
| – | – | – | – | – | – | – | 1 | PVDD overvoltage fault is present |
| – | – | – | – | – | – | 1 | – | PVDD undervoltage fault is present |
| – | – | – | – | – | 1 | – | – | AVDD, analog voltage fault is present |
| – | – | – | – | 1 | – | – | – | Charge-pump voltage fault is present |
| – | – | – | 1 | – | – | – | – | Overtemperature shutdown is present |
| – | – | 1 | – | – | – | – | – | Overtemperature warning |
| – | 1 | 1 | – | – | – | – | – | Overtemperature warning level 1 |
| 1 | 0 | 1 | – | – | – | – | – | Overtemperature warning level 2 |
| 1 | 1 | 1 | – | – | – | – | – | Overtemperature warning level 3 |

Table 10. External Status Register 2 (0x05) Output State of Individual Channels

| D7 | D6 | D5 | D4 | D3 | D2 | D1 | D0 | FUNCTION |
|----|----|----|----|----|----|----|----|--|
| 0 | 0 | 0 | 0 | 1 | 1 | 1 | 1 | Output is in Hi-Z mode, not in low-low mode ⁽¹⁾ , default value |
| – | – | – | – | – | – | – | 0 | Channel 1 Hi-Z mode (0 = not Hi-Z, 1 = Hi-Z) |
| – | – | – | – | – | – | 0 | – | Channel 2 Hi-Z mode (0 = not Hi-Z, 1 = Hi-Z) |
| – | – | – | – | – | 0 | – | – | Channel 3 Hi-Z mode (0 = not Hi-Z, 1 = Hi-Z) |
| – | – | – | – | 0 | – | – | – | Channel 4 Hi-Z mode (0 = not Hi-Z, 1 = Hi-Z) |
| – | – | – | 1 | – | – | – | – | Channel 1 low-low mode (0 = not low-low, 1 = low-low) ⁽¹⁾ |
| – | – | 1 | – | – | – | – | – | Channel 2 low-low mode (0 = not low-low, 1 = low-low) ⁽¹⁾ |
| – | 1 | – | – | – | – | – | – | Channel 3 low-low mode (0 = not low-low, 1 = low-low) ⁽¹⁾ |
| 1 | – | – | – | – | – | – | – | Channel 4 low-low mode (0 = not low-low, 1 = low-low) ⁽¹⁾ |

(1) Low-low is defined as both outputs actively pulled to ground.

Table 11. External Status Register 3 (0x06) Play and Mute Modes

| D7 | D6 | D5 | D4 | D3 | D2 | D1 | D0 | FUNCTION |
|----|----|----|----|----|----|----|----|---|
| 0 | 0 | 0 | 0 | 0 | 0 | 0 | 0 | Mute mode is enabled, play mode disabled, default value |
| – | – | – | – | – | – | – | 1 | Channel 1 play mode is enabled |
| – | – | – | – | – | – | 1 | – | Channel 2 play mode is enabled |
| – | – | – | – | – | 1 | – | – | Channel 3 play mode is enabled |
| – | – | – | – | 1 | – | – | – | Channel 4 play mode is enabled |
| – | – | – | 1 | – | – | – | – | Channel 1 mute mode is disabled |
| – | – | 1 | – | – | – | – | – | Channel 2 mute mode is disabled |
| – | 1 | – | – | – | – | – | – | Channel 3 mute mode is disabled |
| 1 | – | – | – | – | – | – | – | Channel 4 mute mode is disabled |

Table 12. External Status Register 4 (0x07) Load Diagnostics

| D7 | D6 | D5 | D4 | D3 | D2 | D1 | D0 | FUNCTION |
|----|----|----|----|----|----|----|----|---|
| 0 | 0 | 0 | 0 | 0 | 0 | 0 | 0 | No channels are set in load diagnostics mode, default value |
| – | – | – | – | – | – | – | 1 | Channel 1 is in load diagnostics mode |
| – | – | – | – | – | – | 1 | – | Channel 2 is in load diagnostics mode |
| – | – | – | – | – | 1 | – | – | Channel 3 is in load diagnostics mode |
| – | – | – | – | 1 | – | – | – | Channel 4 is in load diagnostics mode |
| X | X | X | X | – | – | – | – | Reserved |

Table 13. External Control Register 1 (0x08) Gain Select

| D7 | D6 | D5 | D4 | D3 | D2 | D1 | D0 | FUNCTION |
|----|----|----|----|----|----|----|----|---|
| 1 | 0 | 1 | 0 | 1 | 0 | 1 | 0 | Set gain for all channels to 26 dB, default value |
| – | – | – | – | – | – | 0 | 0 | Set channel 1 gain to 12 dB |
| – | – | – | – | – | – | 0 | 1 | Set channel 1 gain to 20 dB |
| – | – | – | – | – | – | 1 | 1 | Set channel 1 gain to 32 dB |
| – | – | – | – | 0 | 0 | – | – | Set channel 2 gain to 12 dB |
| – | – | – | – | 0 | 1 | – | – | Set channel 2 gain to 20 dB |
| – | – | – | – | 1 | 1 | – | – | Set channel 2 gain to 32 dB |
| – | – | 0 | 0 | – | – | – | – | Set channel 3 gain to 12 dB |
| – | – | 0 | 1 | – | – | – | – | Set channel 3 gain to 20 dB |
| – | – | 1 | 1 | – | – | – | – | Set channel 3 gain to 32 dB |
| 0 | 0 | – | – | – | – | – | – | Set channel 4 gain to 12 dB |
| 0 | 1 | – | – | – | – | – | – | Set channel 4 gain to 20 dB |
| 1 | 1 | – | – | – | – | – | – | Set channel 4 gain to 32 dB |

Table 14. External Control Register 2 (0x09) DC Offset Reduction and Current Limit

| D7 | D6 | D5 | D4 | D3 | D2 | D1 | D0 | FUNCTION |
|----|----|----|----|----|----|----|----|--|
| 0 | 0 | 0 | 0 | 0 | 0 | 0 | 0 | Enable dc offset reduction, set current limit to level 1 |
| – | – | – | – | – | – | – | 1 | Disable channel 1 dc offset reduction |
| – | – | – | – | – | – | 1 | – | Disable channel 2 dc offset reduction |
| – | – | – | – | – | 1 | – | – | Disable channel 3 dc offset reduction |
| – | – | – | – | 1 | – | – | – | Disable channel 4 dc offset reduction |
| – | – | – | 1 | – | – | – | – | Set channel 1 current limit (0 = level 1, 1 = level 2) |
| – | – | 1 | – | – | – | – | – | Set channel 2 current limit (0 = level 1, 1 = level 2) |
| – | 1 | – | – | – | – | – | – | Set channel 3 current limit (0 = level 1, 1 = level 2) |
| 1 | – | – | – | – | – | – | – | Set channel 4 current limit (0 = level 1, 1 = level 2) |

Table 15. External Control Register 3 (0x0A) Switching Frequency Select and Clip_OTW Configuration

| D7 | D6 | D5 | D4 | D3 | D2 | D1 | D0 | FUNCTION |
|----|----|----|----|----|----|----|----|--|
| 0 | 0 | 0 | 0 | 1 | 1 | 0 | 1 | Set $f_S = 417$ kHz, configure clip and OTW, 45° phase, disable hard stop |
| – | – | – | – | – | – | 0 | 0 | Set $f_S = 500$ kHz |
| – | – | – | – | – | – | 1 | 0 | Set $f_S = 357$ kHz |
| – | – | – | – | – | – | 1 | 1 | Invalid frequency selection (do not set) |
| – | – | – | – | 0 | 0 | – | – | Configure $\overline{\text{CLIP_OTW}}$ pin for tweeter detect only |
| – | – | – | – | 0 | 1 | – | – | Configure $\overline{\text{CLIP_OTW}}$ pin for clip detect only |
| – | – | – | – | 1 | 0 | – | – | Configure $\overline{\text{CLIP_OTW}}$ pin for overtemperature warning only |
| – | – | – | 1 | – | – | – | – | Enable hard-stop mode |
| – | – | 1 | – | – | – | – | – | Set f_S to a 90° phase difference between adjacent channels |
| X | X | – | – | – | – | – | – | Reserved |

Table 16. External Control Register 4 (0x0B) Load Diagnostics and Master/Slave Control

| D7 | D6 | D5 | D4 | D3 | D2 | D1 | D0 | FUNCTION |
|----|----|----|----|----|----|----|----|--|
| 0 | 1 | 0 | 0 | 0 | 0 | 0 | 0 | Disable load diagnostics and dc detect SD, master mode |
| – | – | – | – | – | – | – | 1 | Enable channel 1, load diagnostics |
| – | – | – | – | – | – | 1 | – | Enable channel 2, load diagnostics |
| – | – | – | – | – | 1 | – | – | Enable channel 3, load diagnostics |
| – | – | – | – | 1 | – | – | – | Enable channel 4, load diagnostics |
| – | – | – | 1 | – | – | – | – | Enable dc detect shutdown on all channels |
| – | – | 1 | – | – | – | – | – | Enable tweeter-detect mode |
| – | 0 | – | – | – | – | – | – | Enable slave mode (external oscillator must be provided) |
| X | – | – | – | – | – | – | – | Reserved |

Table 17. External Control Register 5 (0x0C) Output Control

| D7 | D6 | D5 | D4 | D3 | D2 | D1 | D0 | FUNCTION |
|----|----|----|----|----|----|----|----|--|
| 0 | 0 | 0 | 1 | 1 | 1 | 1 | 1 | All channels, Hi-Z, mute, reset disabled |
| – | – | – | – | – | – | – | 0 | Set channel 1 to mute mode, non-Hi-Z |
| – | – | – | – | – | – | 0 | – | Set channel 2 to mute mode, non-Hi-Z |
| – | – | – | – | – | 0 | – | – | Set channel 3 to mute mode, non-Hi-Z |
| – | – | – | – | 0 | – | – | – | Set channel 4 to mute mode, non-Hi-Z |
| – | – | – | 0 | – | – | – | – | Set non-Hi-Z channels to play mode, (unmute) |
| – | 1 | 1 | – | – | – | – | – | Reserved |
| 1 | – | – | – | – | – | – | – | Reset device (I ² C does not respond with an ACK) |

Table 18. External Control Register 6 (0x0D) Output Control

| D7 | D6 | D5 | D4 | D3 | D2 | D1 | D0 | FUNCTION |
|----|----|----|----|----|----|----|----|-------------------------------------|
| 0 | 0 | 0 | 0 | 0 | 0 | 0 | 0 | Low-low state disabled all channels |
| – | – | – | – | – | – | – | 1 | Set channel 1 to low-low state |
| – | – | – | – | – | – | 1 | – | Set channel 2 to low-low state |
| – | – | – | – | – | 1 | – | – | Set channel 3 to low-low state |
| – | – | – | – | 1 | – | – | – | Set channel 4 to low-low state |
| X | X | X | X | – | – | – | – | Reserved |

Table 19. External Control Register 7 (0x0E) Positive DC Detect Threshold Selection

| D7 | D6 | D5 | D4 | D3 | D2 | D1 | D0 | FUNCTION |
|----|----|----|----|----|----|----|----|---|
| 1 | 0 | 0 | 0 | 1 | 1 | 1 | 0 | Default positive dc detect value |
| 0 | 1 | 1 | 0 | 0 | 1 | 0 | 1 | Minimum positive dc detect value |
| X | X | X | X | X | X | X | X | See Figure 11 to set positive dc detect value |
| 1 | 1 | 0 | 0 | 1 | 0 | 1 | 1 | Maximum positive dc detect value |

Table 20. External Control Register 8 (0x0F) Negative DC Detect Threshold Selection

| D7 | D6 | D5 | D4 | D3 | D2 | D1 | D0 | FUNCTION |
|----|----|----|----|----|----|----|----|---|
| 0 | 0 | 1 | 1 | 1 | 1 | 0 | 1 | Default negative dc detect value |
| 0 | 1 | 1 | 0 | 0 | 1 | 0 | 1 | Minimum negative dc detect value |
| X | X | X | X | X | X | X | X | See Figure 12 to set negative dc detect value |
| 0 | 0 | 0 | 0 | 0 | 0 | 0 | 0 | Maximum negative dc detect value |

Hardware Control Pins

The TAS5414 and TAS5424 incorporate four discrete hardware pins for real-time control and indication of device status.

FAULT pin: This active-low, open-drain output pin indicates the presence of a fault condition that requires the TAS5414 and TAS5424 to go automatically into the Hi-Z mode or standby mode. When this pin is asserted high, the device has acted to protect itself and the system from potential damage. The exact nature of the fault can be read via I²C with the exception of faults that are the result of PVDD voltage excursions above 25 Vdc or below 5.5 Vdc. In these instances, the device goes into standby mode and the I²C bus is no longer operational. However, the fault is still indicated due to the fact that the **FAULT** pin is open-drain and active-high.

CLIP_OTW pin: The function of this active-high pin is configured by the user to indicate one of the following conditions: overtemperature warning, the detection of clipping, or the logical OR of both of these conditions. The configuration is selected via I²C. During tweeter detect diagnostics, this pin also is asserted when a tweeter is present.

MUTE pin: This active-low pin is used for hardware control of the mute/unmute function for all four channels. Capacitor C_{MUTE} is used to control the time constant for the gain ramp needed to produce a pop- and click-free mute function. For pop- and click-free operation, the mute function should be implemented through I²C commands. The use of a hard mute with an external transistor does not ensure pop- and click-free operation, and is not recommended unless an *emergency hard mute* function is required in case of a loss of I²C control. The value of C_{MUTE} must be 330 nF for proper pop- and click-free operation.

STANDBY pin: When this active-low pin is asserted, the device goes into a complete shutdown, and current draw is limited to 2 μA, typical. This pin typically asserted when the car ignition is in the off position. It can also be used to shut down the device rapidly when certain operating conditions are violated. All I²C register content is lost when this pin is asserted. The I²C bus goes into the high-impedance state when the **STANDBY** pin is asserted.

EMI Considerations

Automotive level EMI performance depends on both careful integrated circuit design and good system level design. Controlling sources of electromagnetic interference (EMI) was a major consideration in all aspects of the TAS5414 and TAS5424 design.

The TAS5414 and TAS5424 have minimal parasitic inductances due to the short leads on the PSOP3 package. This dramatically reduces the EMI that results from current passing from the die to the system PCB. Each channel of the TAS5414 and TAS5424 also operates at a different phase. The phase between channels is I²C selectable to either 45° or 90°, to reduce EMI caused by high-current switching. The TAS5414 and TAS5424 incorporate patent-pending circuitry that optimizes output transitions that cause EMI.

AM Radio EMI Reduction

To reduce interference in the AM radio band, the TAS5414 and TAS5424 have the ability to change the switching frequency via I²C commands. The recommended frequencies are listed in Table 21. The fundamental frequency and its second harmonic straddle the AM radio band listed. This eliminates the tones that can be present due to the switching frequency being demodulated by the AM radio. To function properly, AM avoidance requires the use of a 20-kΩ, 1% tolerance Rext resistor.

Table 21. Recommended Switching Frequencies for AM Mode Operation

| US | | EUROPEAN | |
|--------------------|---------------------------|--------------------|---------------------------|
| AM FREQUENCY (kHz) | SWITCHING FREQUENCY (kHz) | AM FREQUENCY (kHz) | SWITCHING FREQUENCY (kHz) |
| | | 522-540 | 417 |
| 540-917 | 500 | 540-914 | 500 |
| 917-1125 | 417 | 914-1122 | 417 |
| 1125-1375 | 500 | 1122-1373 | 500 |
| 1375-1547 | 417 | 1373-1548 | 417 |
| 1547-1700 | 357 | 1548-1701 | 357 |

Operating States

The operating regions, or states, of the TAS5414 and TAS5424 are depicted in the following tables.

Table 22. Operating States and Supplies

| STATE NAME | OUTPUT FETS | CHARGE PUMP | OSCILLATOR | I ² C | AVDD and DVDD |
|------------------|----------------------|-------------|------------|------------------|---------------|
| STANDBY | Hi-Z, floating | Stopped | Stopped | Stopped | OFF |
| Hi-Z | Hi-Z, weak pulldown | Active | Active | Active | ON |
| Mute | Switching at 50% | Active | Active | Active | ON |
| Normal operation | Switching with audio | Active | Active | Active | ON |

Table 23. Global Faults and Actions

| FAULT/ EVENT | FAULT/EVENT CATEGORY | MONITORING MODES | REPORTING METHOD | ACTION TYPE | ACTION RESULT | LATCHED/ SELF-CLEARING |
|--------------|----------------------|--------------------|--|---------------------|---------------|------------------------|
| POR | Voltage fault | All | $\overline{\text{FAULT}}$ pin | Hard mute (no ramp) | Standby | Self-clearing |
| UV | | Hi-Z, mute, normal | I ² C + $\overline{\text{FAULT}}$ pin | | Hi-Z | |
| CP UV | | | | | Hi-Z | |
| OV | | | | | Hi-Z | |
| Load dump | | All | $\overline{\text{FAULT}}$ pin | | Standby | |
| OTW | Thermal warning | Hi-Z, mute, normal | I ² C + $\overline{\text{CLIP_OTW}}$ pin | None | None | Self-clearing |
| OT | Thermal fault | Hi-Z, mute, normal | I ² C + $\overline{\text{FAULT}}$ pin | Hard mute | Standby | Self-clearing |

Table 24. Channel Faults and Actions

| FAULT/ EVENT | FAULT/EVENT CATEGORY | MONITORING MODES | REPORTING METHOD | ACTION TYPE | ACTION RESULT | LATCHED/ SELF-CLEARING |
|------------------------|----------------------|-----------------------------------|-----------------------------------|---------------|----------------|------------------------|
| Open/short diagnostic | Diagnostic | Hi-Z (I ² C activated) | I ² C | None | None | Latched |
| Clipping online | Warning | Normal | $\overline{\text{CLIP_OTW}}$ pin | None | None | Self-clearing |
| CBC load current limit | Online protection | Mute, normal | $\overline{\text{CLIP_OTW}}$ pin | Current limit | Start OC timer | Self-clearing |
| OC fault | Output channel fault | Mute, normal | I ² C + FAULT pin | Hard mute | Hi-Z | Latched |
| DC detect | | Normal | I ² C + FAULT pin | Hard mute | Hi-Z | Latched |

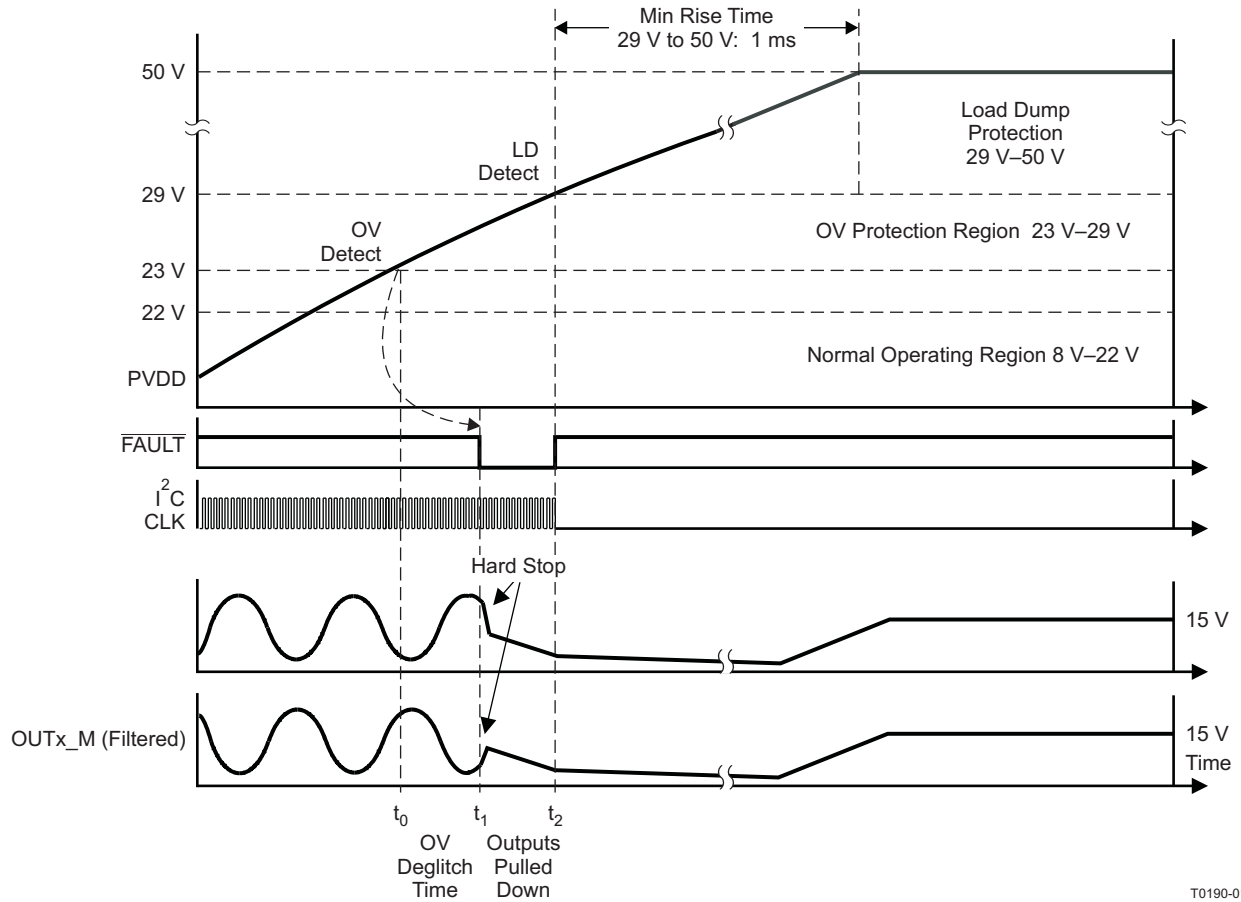

Figure 21. Sequence of Events for Supply Transition Out of Normal Operating Region

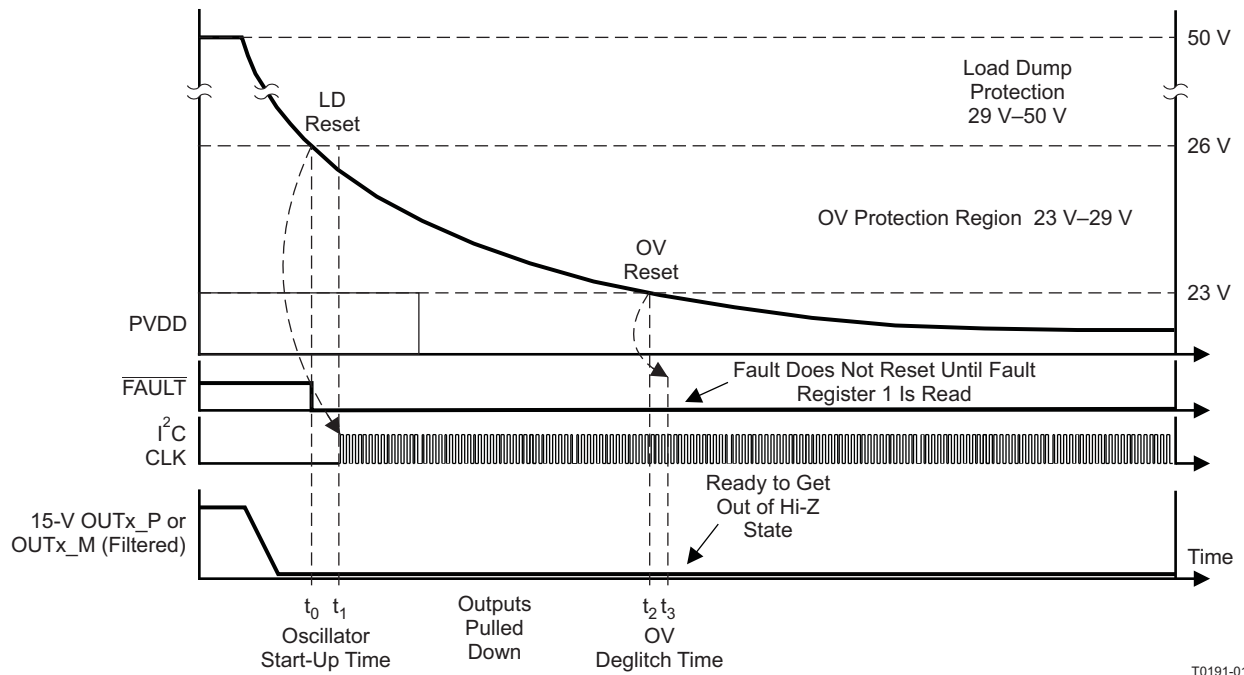
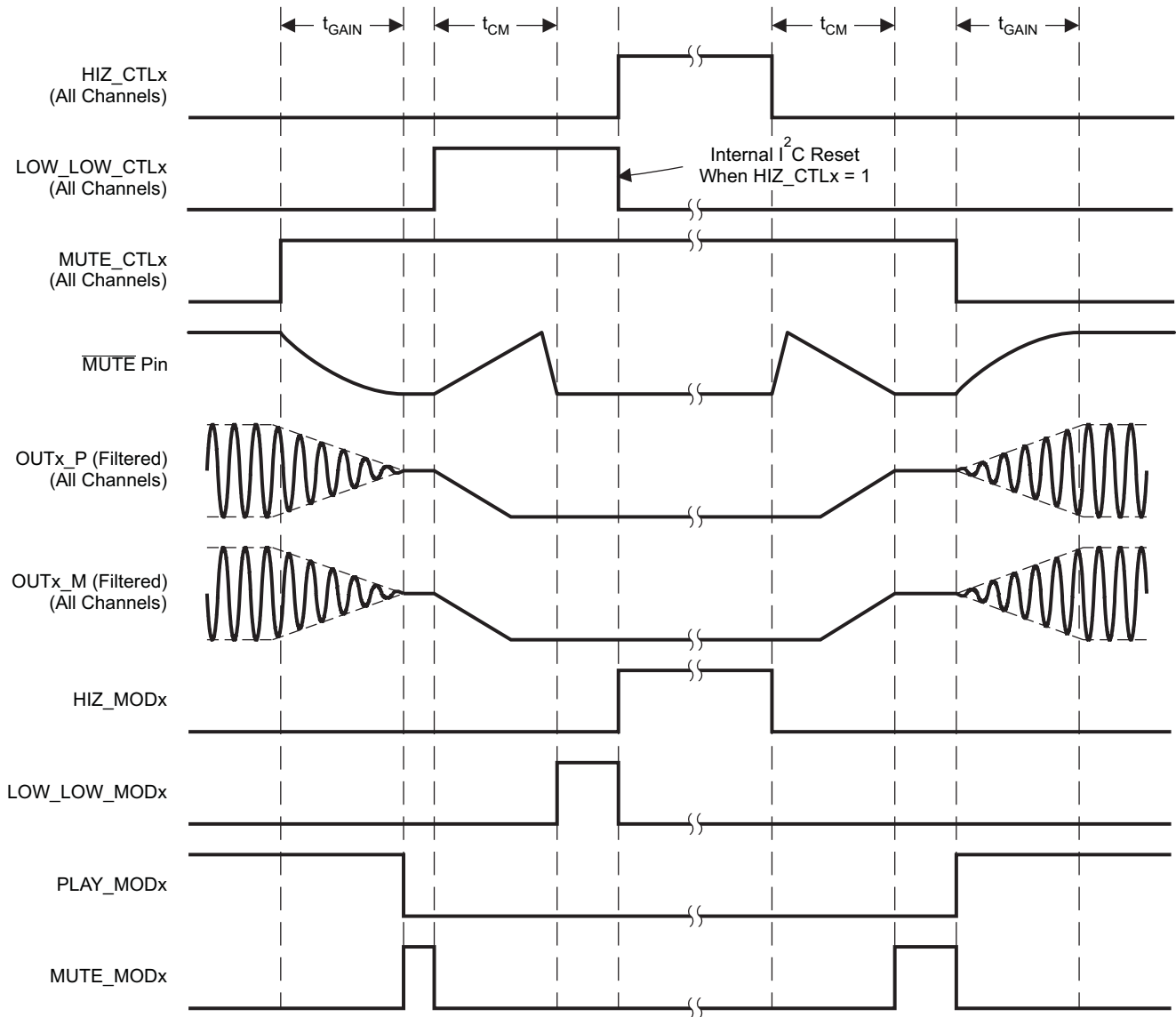

Figure 22. Sequence of Events for Supply Transition Back Into Normal Operating Region

Power Shutdown and Restart Sequence Control



T0192-01

**Figure 23. Click- and Pop-Free Shutdown and Restart Sequence Timing Diagram
With Four Channels Sharing the Mute Pin**

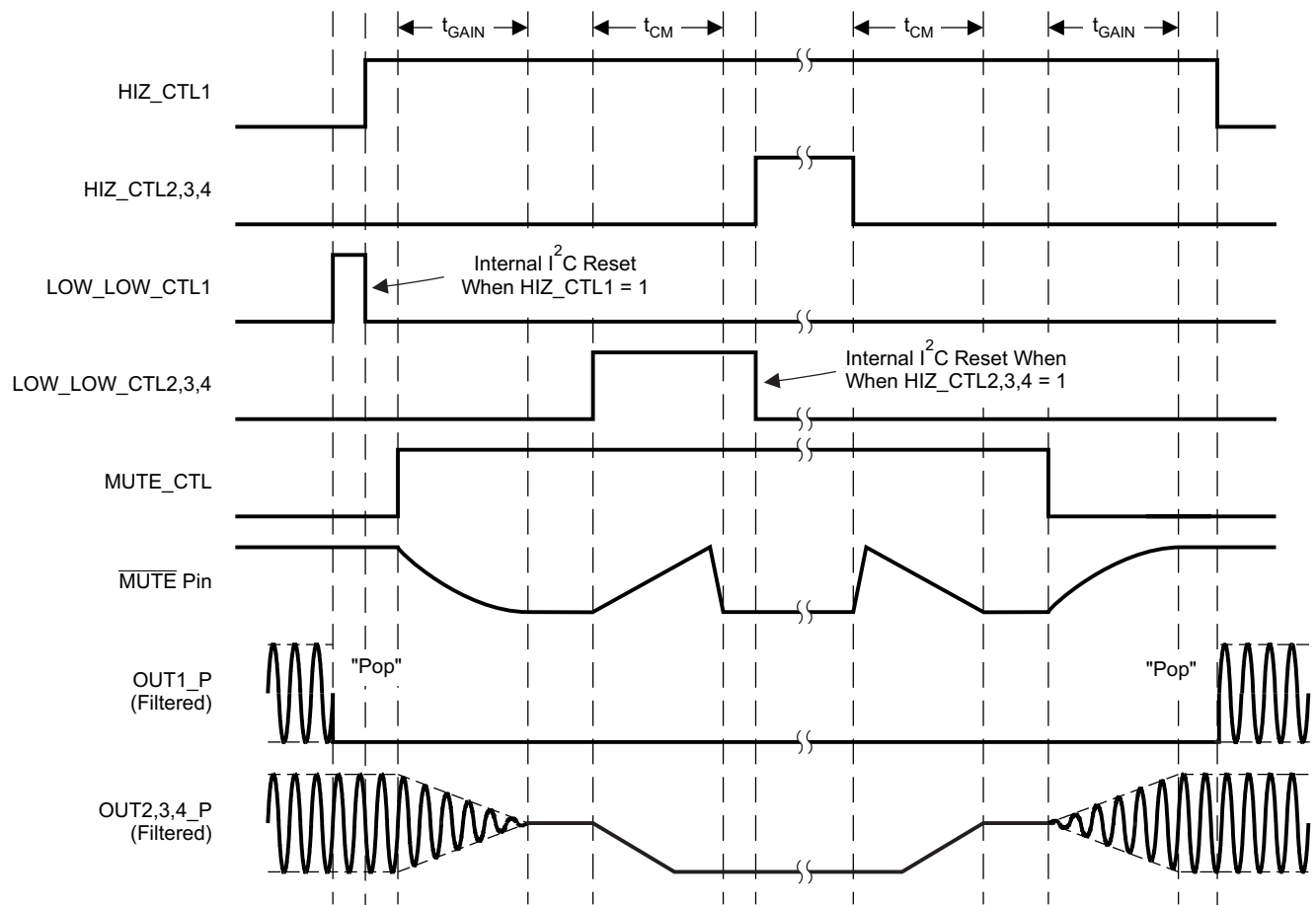

T0193-01

Figure 24. Individual Channel Shutdown and Restart Sequence Timing Diagram

Latched Fault Shutdown and Restart Sequence Control

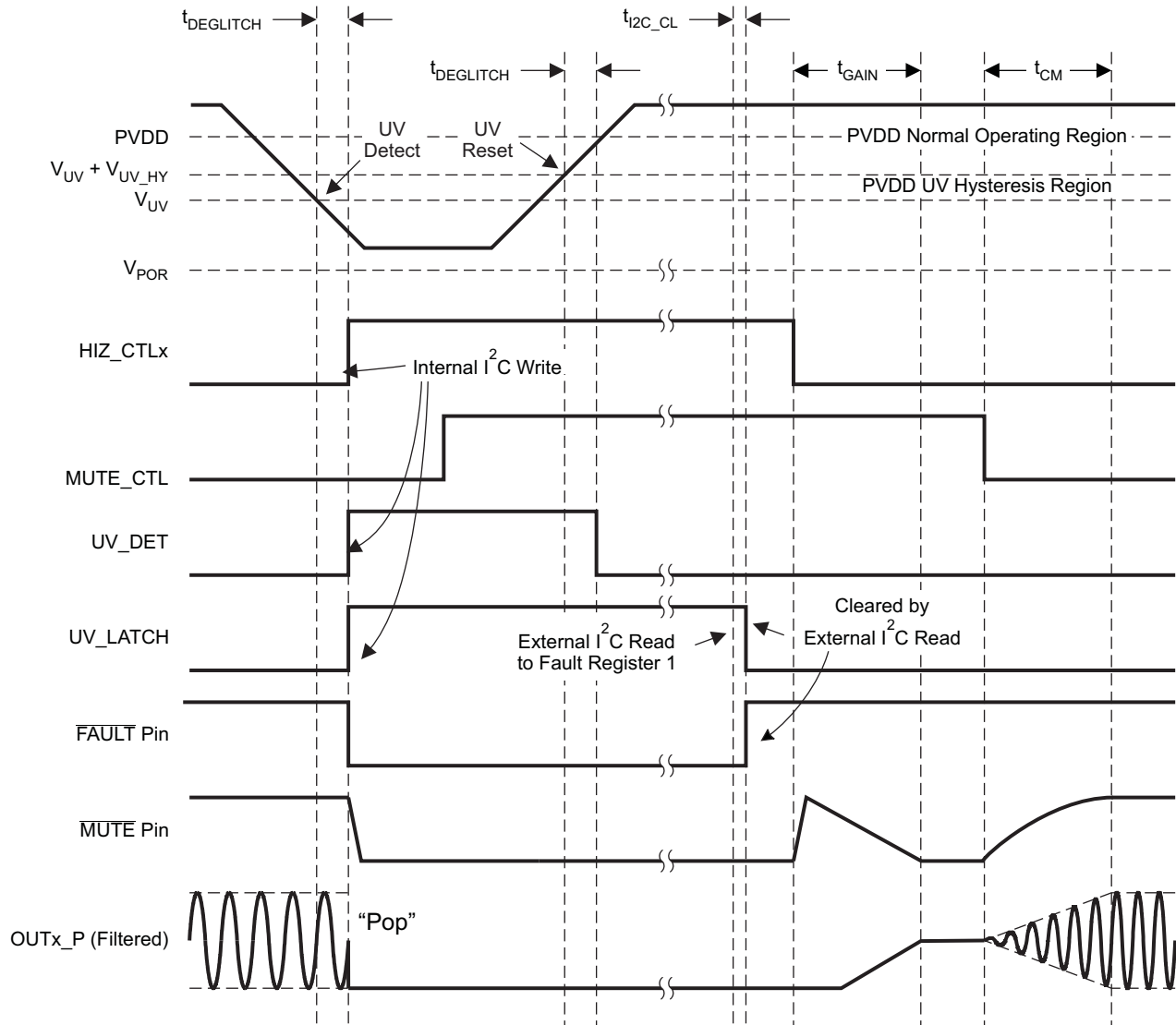

T0194-01

**Figure 25. Latched Global Fault Shutdown and Restart Timing Diagram
(UV Shutdown and Recovery)**

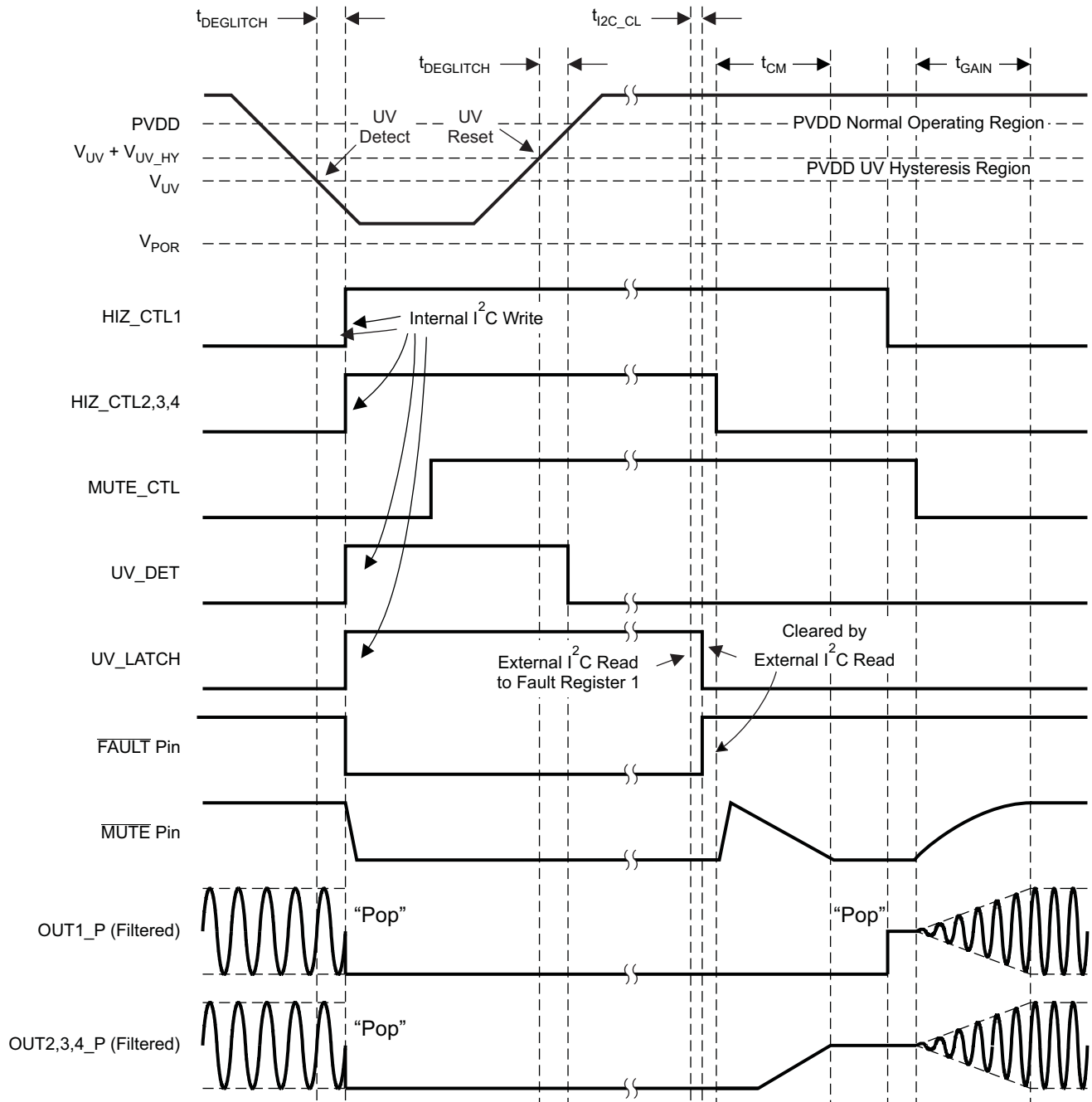

T0195-01

Figure 26. Latched Global Fault Shutdown and Individual Channel Restart Timing Diagram (UV Shutdown and Recovery)

APPLICATION INFORMATION

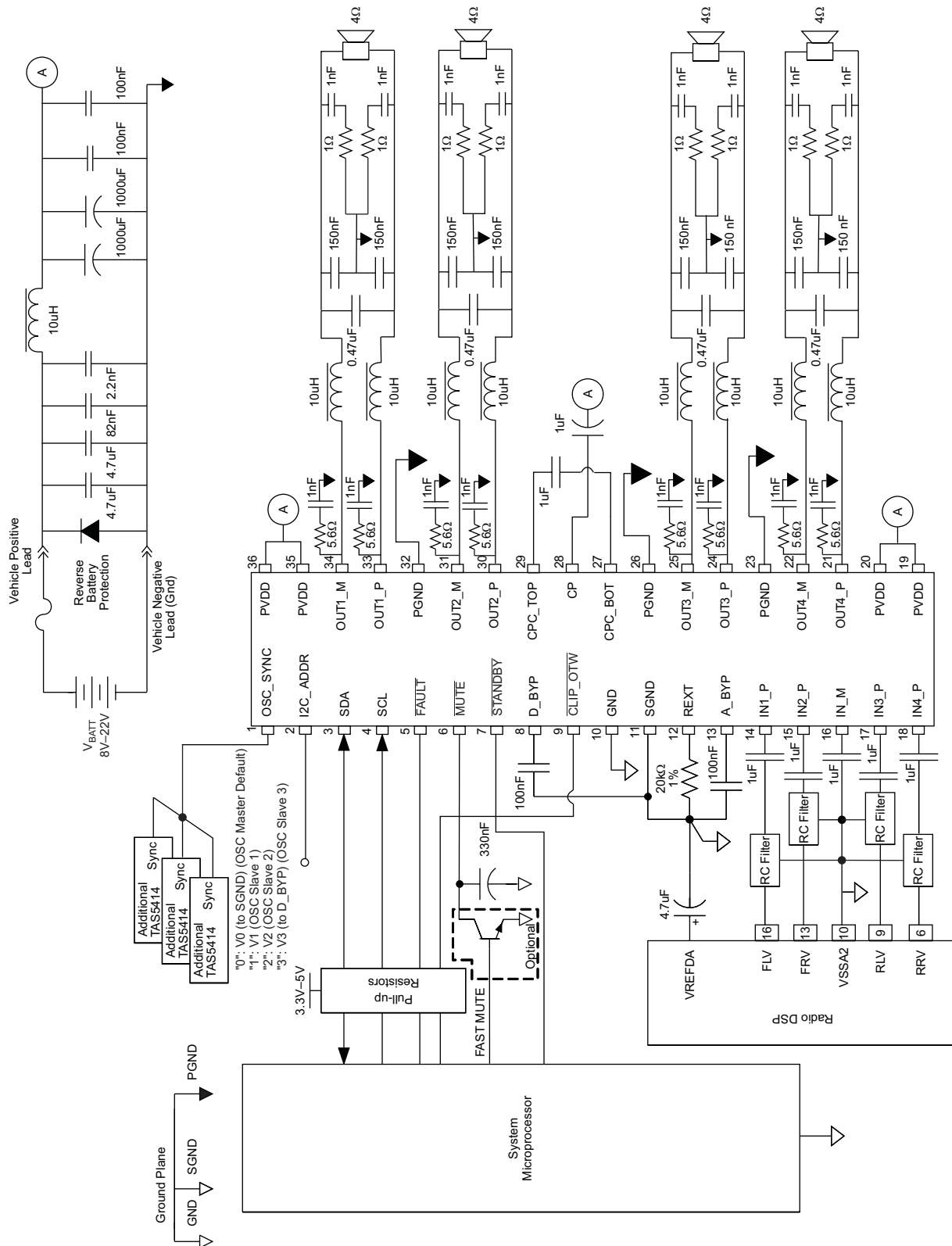

S0235-01

Figure 27. TAS5414 Application Schematic

APPLICATION INFORMATION (continued)

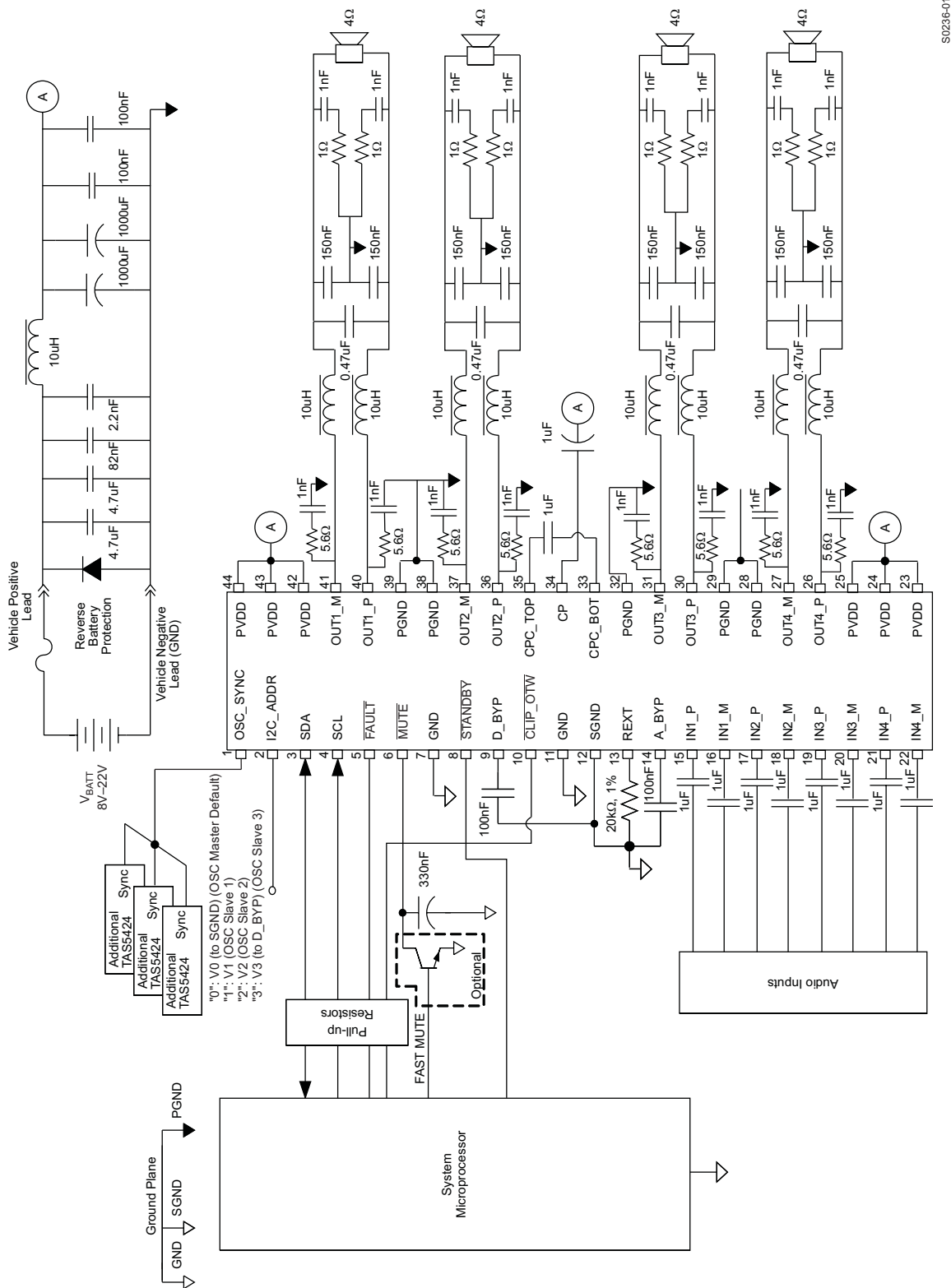

S0236-01

Figure 28. TAS5424 Typical Application Schematic

APPLICATION INFORMATION (continued)

Parallel Operation (PBTL)

TAS5414 and TAS5424 can be used to drive four 4Ω loads, two 2Ω loads, or even one 1Ω load by paralleling BTL channels on the load side of the LC output filter. For parallel operation, identical I²C settings are required for any two paralleled channels (especially gain and current-limit settings) in order to have reliable system performance and evenly dissipated power on multiple channels. Having identical gain and current-limit settings can also prevent energy feeding back from one channel to the other. For smooth power up, power down, and mute operation, the same control commands (such as mute, play, Hi-Z, etc.) should be sent to the paralleled channels at the same time. Load diagnostic is also supported for parallel connection. Paralleling on the TAS5414 and TAS5424 side of the LC output filter is not supported, and can result in device failure.

DEMODULATION FILTER DESIGN

The TAS5414 and TAS5424 amplifier outputs are driven by high-current LDMOS transistors in an H-bridge configuration. These transistors are either off or fully on. The result is a square-wave output signal with a duty cycle that is proportional to the amplitude of the audio signal. It is recommended that a second-order LC filter be used to recover the audio signal. The main purpose of the demodulation filter is to attenuate the high-frequency components of the output signals that are out of the audio band. Design of the demodulation filter significantly affects the audio performance of the power amplifier. Therefore, to meet the device THD+N specification, the selection of the inductors used in the output filter should be carefully considered. The rule is that the inductance should remain stable within the range of peak current seen at maximum output power and deliver approximately $5\ \mu\text{H}$ of inductance at 16 A. If this rule is observed, the TAS5414 and TAS5424 should not have distortion issues due to the output inductors. Another parameter to be considered is the idle-current loss in the inductor. This can be measured or specified as inductor dissipation (D). The target specification for dissipation is less than 0.05. If the dissipation factor is above this value, idle current increases. In general, $10\text{-}\mu\text{H}$ inductors suffice for most applications. The frequency response of the amplifier is slightly altered by the change in output load resistance; however, unless tight control of frequency response is necessary (better than 0.5 dB), it is not necessary to deviate from $10\ \mu\text{H}$.

THERMAL INFORMATION

The thermally augmented package provided with the TAS5414 and TAS5424 is designed to interface directly to heat sinks using a thermal interface compound (for example, Artic Silver, Ceramique thermal compound.) The heat sink then absorbs heat from the ICs and couples it to the local air. If louvers or fans are supplied, this process can reach equilibrium and heat can be continually removed from the ICs. Because of the efficiency of the TAS5414 and TAS5424, heat sinks can be smaller than those required for linear amplifiers of equivalent performance.

$R_{\theta JA}$ is a system thermal resistance from junction to ambient air. As such, it is a system parameter with the following components:

- $R_{\theta JC}$ (the thermal resistance from junction to case, or in this case the heat slug)
- Thermal grease thermal resistance
- Heat sink thermal resistance

The thermal grease thermal resistance can be calculated from the exposed heat slug area and the thermal grease manufacturer's area thermal resistance (expressed in $^{\circ}\text{C}\text{-in}^2/\text{W}$ or $^{\circ}\text{C}\text{-mm}^2/\text{W}$). The area thermal resistance of the example thermal grease with a 0.001-inch (0.0254-mm) thick layer is about $0.007^{\circ}\text{C}\text{-in}^2/\text{W}$ ($4.52^{\circ}\text{C}\text{-mm}^2/\text{W}$). The approximate exposed heat slug size is as follows:

| | |
|-----------------------------|--|
| TAS5424, 44-pin PSOP3 | $0.124\ \text{in}^2$ ($80\ \text{mm}^2$) |
| TAS5414, 36-pin PSOP3 | $0.124\ \text{in}^2$ ($80\ \text{mm}^2$) |

Dividing the example thermal grease area resistance by the area of the heat slug gives the actual resistance through the thermal grease for both parts:

| | |
|-----------------------------|---------------------------------|
| TAS5424, 44-pin PSOP3 | $0.40^{\circ}\text{C}/\text{W}$ |
| TAS5414, 36-pin PSOP3 | $0.40^{\circ}\text{C}/\text{W}$ |

APPLICATION INFORMATION (continued)

The thermal resistance of thermal pads is generally considerably higher than a thin thermal grease layer. Thermal tape has an even higher thermal resistance and should not be used at all. Heat sink thermal resistance generally is predicted by the heat sink vendor, modeled using a continuous flow dynamics (CFD) model, or measured.

Thus, for a single monaural channel in the IC, the system $R_{\theta JA} = R_{\theta JC} + \text{thermal grease resistance} + \text{heat sink resistance}$.

The following table indicates modeled parameters for one TAS5414 or TAS5424 IC on a heat sink. The junction temperature is set at 115°C in both cases while delivering 20 Wrms per channel into 4-Ω loads with no clipping. It is assumed that the thermal grease is about 0.001 inches (0.0254 mm) thick (this is critical).

| Device | TAS5414, 36-Pin PSOP3 |
|---|-----------------------|
| Ambient temperature | 25°C |
| Power to load | 20 W × 4 |
| Power dissipation | 1.90 W × 4 |
| ΔT inside package | 7.6°C |
| ΔT through thermal grease | 3°C |
| Required heatsink thermal resistance | 10.45°C/W |
| Junction temperature | 115°C |
| System $R_{\theta JA}$ | 11.85°C/W |
| $R_{\theta JA} \times \text{power dissipation}$ | 90°C |

As an indication of the importance of keeping the thermal grease layer thin, if the thermal grease layer increases to 0.002 inches (0.0508 mm) thick, the required heat sink thermal resistance changes to 6°C/W for the PSOP3.

PACKAGING INFORMATION

| Orderable Device | Status ⁽¹⁾ | Package Type | Package Drawing | Pins | Package Qty | Eco Plan ⁽²⁾ | Lead/Ball Finish | MSL Peak Temp ⁽³⁾ |
|-------------------|-----------------------|--------------|-----------------|------|-------------|-------------------------|------------------|------------------------------|
| TAS5414TDKDMQ1 | NRND | SSOP | DKD | 36 | 29 | Green (RoHS & no Sb/Br) | CU NIPDAU | Level-3-245C-168 HR |
| TAS5414TDKDMQ1G4 | NRND | SSOP | DKD | 36 | 29 | Green (RoHS & no Sb/Br) | CU NIPDAU | Level-3-245C-168 HR |
| TAS5414TDKDQ1 | NRND | SSOP | DKD | 36 | 29 | Green (RoHS & no Sb/Br) | CU NIPDAU | Level-3-245C-168 HR |
| TAS5414TDKDQ1G4 | NRND | SSOP | DKD | 36 | 29 | Green (RoHS & no Sb/Br) | CU NIPDAU | Level-3-245C-168 HR |
| TAS5414TDKDRMQ1 | NRND | SSOP | DKD | 36 | 500 | Green (RoHS & no Sb/Br) | CU NIPDAU | Level-3-245C-168 HR |
| TAS5414TDKDRMQ1G4 | NRND | SSOP | DKD | 36 | 500 | Green (RoHS & no Sb/Br) | CU NIPDAU | Level-3-245C-168 HR |
| TAS5414TDKDRQ1 | NRND | SSOP | DKD | 36 | 500 | Green (RoHS & no Sb/Br) | CU NIPDAU | Level-3-245C-168 HR |
| TAS5414TDKDRQ1G4 | NRND | SSOP | DKD | 36 | 500 | Green (RoHS & no Sb/Br) | CU NIPDAU | Level-3-245C-168 HR |
| TAS5424TDKDQ1 | NRND | SSOP | DKD | 44 | 29 | Green (RoHS & no Sb/Br) | CU NIPDAU | Level-3-245C-168 HR |
| TAS5424TDKDQ1G4 | NRND | SSOP | DKD | 44 | 29 | Green (RoHS & no Sb/Br) | CU NIPDAU | Level-3-245C-168 HR |
| TAS5424TDKDRQ1 | NRND | SSOP | DKD | 44 | 500 | Green (RoHS & no Sb/Br) | CU NIPDAU | Level-3-245C-168 HR |
| TAS5424TDKDRQ1G4 | NRND | SSOP | DKD | 44 | 500 | Green (RoHS & no Sb/Br) | CU NIPDAU | Level-3-245C-168 HR |

⁽¹⁾ The marketing status values are defined as follows:

ACTIVE: Product device recommended for new designs.

LIFEBUY: TI has announced that the device will be discontinued, and a lifetime-buy period is in effect.

NRND: Not recommended for new designs. Device is in production to support existing customers, but TI does not recommend using this part in a new design.

PREVIEW: Device has been announced but is not in production. Samples may or may not be available.

OBSOLETE: TI has discontinued the production of the device.

⁽²⁾ Eco Plan - The planned eco-friendly classification: Pb-Free (RoHS), Pb-Free (RoHS Exempt), or Green (RoHS & no Sb/Br) - please check <http://www.ti.com/productcontent> for the latest availability information and additional product content details.

TBD: The Pb-Free/Green conversion plan has not been defined.

Pb-Free (RoHS): TI's terms "Lead-Free" or "Pb-Free" mean semiconductor products that are compatible with the current RoHS requirements for all 6 substances, including the requirement that lead not exceed 0.1% by weight in homogeneous materials. Where designed to be soldered at high temperatures, TI Pb-Free products are suitable for use in specified lead-free processes.

Pb-Free (RoHS Exempt): This component has a RoHS exemption for either 1) lead-based flip-chip solder bumps used between the die and package, or 2) lead-based die adhesive used between the die and leadframe. The component is otherwise considered Pb-Free (RoHS compatible) as defined above.

Green (RoHS & no Sb/Br): TI defines "Green" to mean Pb-Free (RoHS compatible), and free of Bromine (Br) and Antimony (Sb) based flame retardants (Br or Sb do not exceed 0.1% by weight in homogeneous material)

⁽³⁾ MSL, Peak Temp. -- The Moisture Sensitivity Level rating according to the JEDEC industry standard classifications, and peak solder temperature.

Important Information and Disclaimer: The information provided on this page represents TI's knowledge and belief as of the date that it is provided. TI bases its knowledge and belief on information provided by third parties, and makes no representation or warranty as to the accuracy of such information. Efforts are underway to better integrate information from third parties. TI has taken and continues to take reasonable steps to provide representative and accurate information but may not have conducted destructive testing or chemical analysis on incoming materials and chemicals. TI and TI suppliers consider certain information to be proprietary, and thus CAS numbers and other limited information may not be available for release.

In no event shall TI's liability arising out of such information exceed the total purchase price of the TI part(s) at issue in this document sold by TI to Customer on an annual basis.

TAPE AND REEL BOX INFORMATION

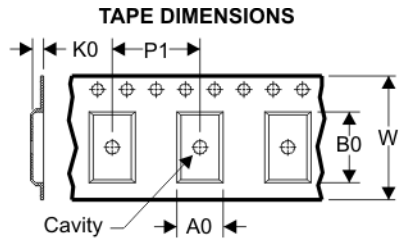

| | |
|----|---|
| A0 | Dimension designed to accommodate the component width |
| B0 | Dimension designed to accommodate the component length |
| K0 | Dimension designed to accommodate the component thickness |
| W | Overall width of the carrier tape |
| P1 | Pitch between successive cavity centers |

QUADRANT ASSIGNMENTS FOR PIN 1 ORIENTATION IN TAPE

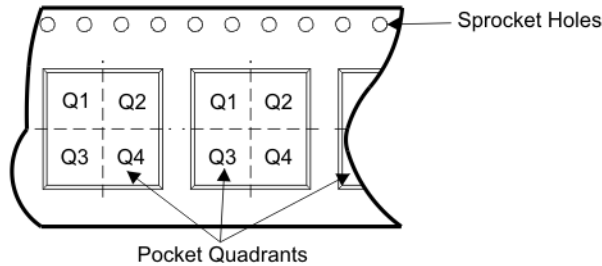

| Device | Package | Pins | Site | Reel Diameter (mm) | Reel Width (mm) | A0 (mm) | B0 (mm) | K0 (mm) | P1 (mm) | W (mm) | Pin1 Quadrant |
|-----------------|---------|------|---------|--------------------|-----------------|---------|---------|---------|---------|--------|---------------|
| TAS5414TDKDRMQ1 | DKD | 36 | SITE 60 | 330 | 24 | 14.7 | 16.4 | 4.0 | 20 | 24 | Q1 |
| TAS5414TDKDRQ1 | DKD | 36 | SITE 60 | 330 | 24 | 14.7 | 16.4 | 4.0 | 20 | 24 | Q1 |
| TAS5424TDKDRQ1 | DKD | 44 | SITE 60 | 330 | 24 | 14.7 | 16.4 | 4.0 | 20 | 24 | Q1 |

TAPE AND REEL BOX DIMENSIONS



| Device | Package | Pins | Site | Length (mm) | Width (mm) | Height (mm) |
|-----------------|---------|------|---------|-------------|------------|-------------|
| TAS5414TDKDRMQ1 | DKD | 36 | SITE 60 | 367.0 | 367.0 | 45.0 |
| TAS5414TDKDRQ1 | DKD | 36 | SITE 60 | 367.0 | 367.0 | 45.0 |
| TAS5424TDKDRQ1 | DKD | 44 | SITE 60 | 367.0 | 367.0 | 45.0 |

DKD (R-PDSO-G36)

PLASTIC SMALL OUTLINE

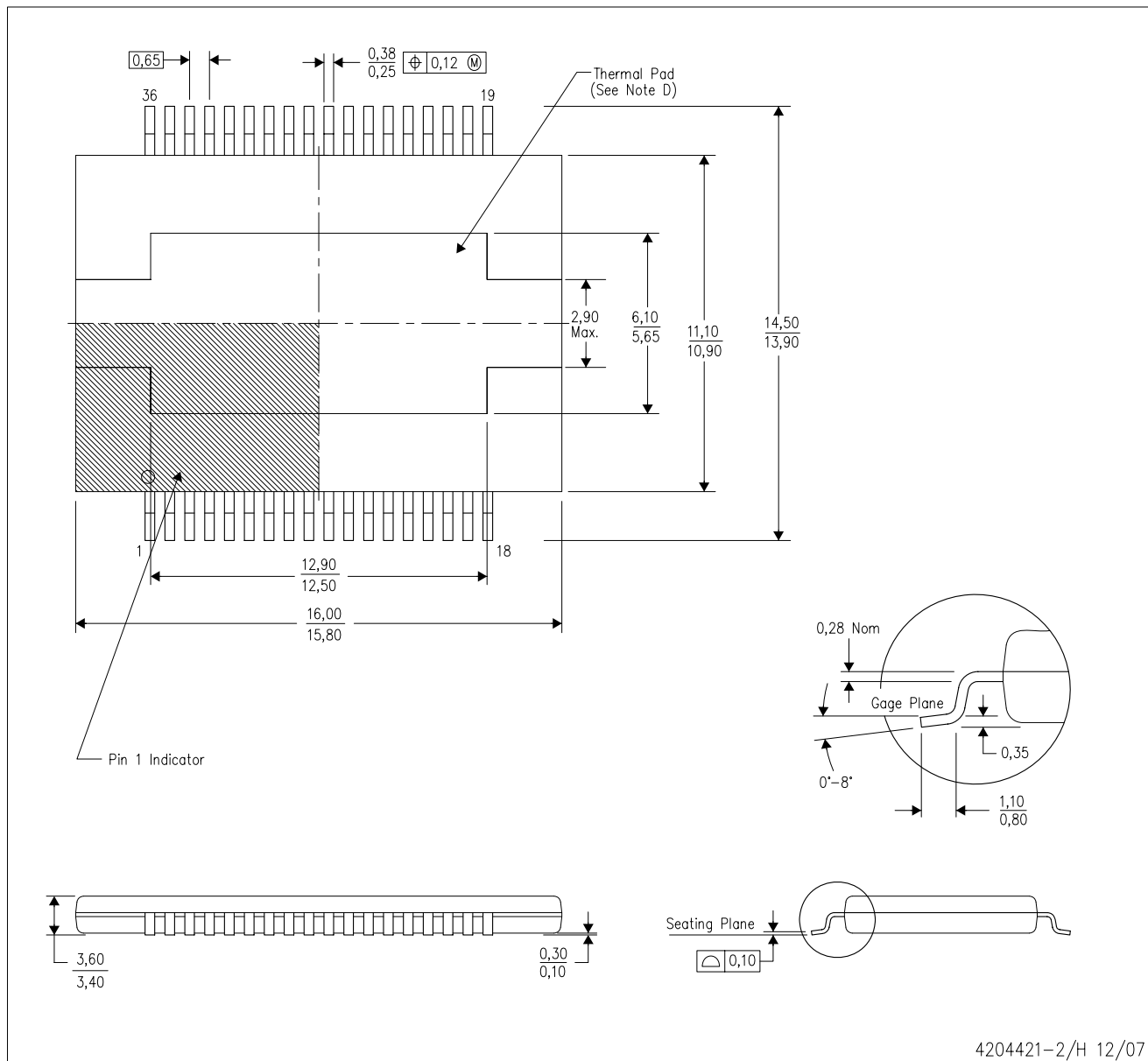

- NOTES:
- A. All linear dimensions are in millimeters.
 - B. This drawing is subject to change without notice.
 - C. Body dimensions do not include mold flash or protrusion not to exceed 0.15mm.
 - D. The package thermal performance is optimized for conductive cooling with attachment to an external heat sink. See the product data sheet for details regarding the exposed thermal pad dimensions.

DKD (R-PDSO-G44)

PLASTIC SMALL OUTLINE

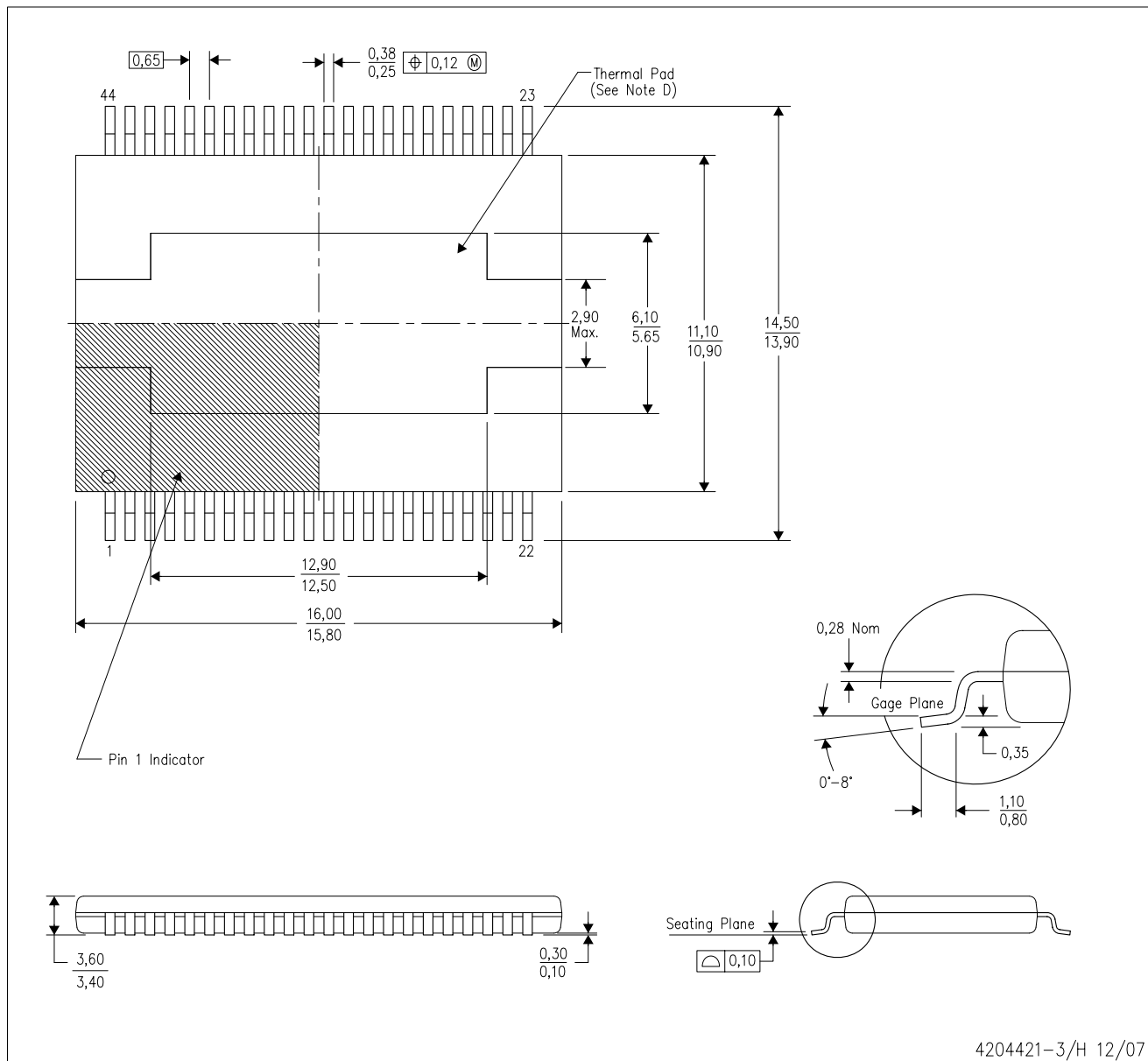

- NOTES:
- A. All linear dimensions are in millimeters.
 - B. This drawing is subject to change without notice.
 - C. Body dimensions do not include mold flash or protrusion not to exceed 0.15mm.
 - D. The package thermal performance is optimized for conductive cooling with attachment to an external heat sink. See the product data sheet for details regarding the exposed thermal pad dimensions.

IMPORTANT NOTICE

Texas Instruments Incorporated and its subsidiaries (TI) reserve the right to make corrections, modifications, enhancements, improvements, and other changes to its products and services at any time and to discontinue any product or service without notice. Customers should obtain the latest relevant information before placing orders and should verify that such information is current and complete. All products are sold subject to TI's terms and conditions of sale supplied at the time of order acknowledgment.

TI warrants performance of its hardware products to the specifications applicable at the time of sale in accordance with TI's standard warranty. Testing and other quality control techniques are used to the extent TI deems necessary to support this warranty. Except where mandated by government requirements, testing of all parameters of each product is not necessarily performed.

TI assumes no liability for applications assistance or customer product design. Customers are responsible for their products and applications using TI components. To minimize the risks associated with customer products and applications, customers should provide adequate design and operating safeguards.

TI does not warrant or represent that any license, either express or implied, is granted under any TI patent right, copyright, mask work right, or other TI intellectual property right relating to any combination, machine, or process in which TI products or services are used. Information published by TI regarding third-party products or services does not constitute a license from TI to use such products or services or a warranty or endorsement thereof. Use of such information may require a license from a third party under the patents or other intellectual property of the third party, or a license from TI under the patents or other intellectual property of TI.

Reproduction of TI information in TI data books or data sheets is permissible only if reproduction is without alteration and is accompanied by all associated warranties, conditions, limitations, and notices. Reproduction of this information with alteration is an unfair and deceptive business practice. TI is not responsible or liable for such altered documentation. Information of third parties may be subject to additional restrictions.

Resale of TI products or services with statements different from or beyond the parameters stated by TI for that product or service voids all express and any implied warranties for the associated TI product or service and is an unfair and deceptive business practice. TI is not responsible or liable for any such statements.

TI products are not authorized for use in safety-critical applications (such as life support) where a failure of the TI product would reasonably be expected to cause severe personal injury or death, unless officers of the parties have executed an agreement specifically governing such use. Buyers represent that they have all necessary expertise in the safety and regulatory ramifications of their applications, and acknowledge and agree that they are solely responsible for all legal, regulatory and safety-related requirements concerning their products and any use of TI products in such safety-critical applications, notwithstanding any applications-related information or support that may be provided by TI. Further, Buyers must fully indemnify TI and its representatives against any damages arising out of the use of TI products in such safety-critical applications.

TI products are neither designed nor intended for use in military/aerospace applications or environments unless the TI products are specifically designated by TI as military-grade or "enhanced plastic." Only products designated by TI as military-grade meet military specifications. Buyers acknowledge and agree that any such use of TI products which TI has not designated as military-grade is solely at the Buyer's risk, and that they are solely responsible for compliance with all legal and regulatory requirements in connection with such use.

TI products are neither designed nor intended for use in automotive applications or environments unless the specific TI products are designated by TI as compliant with ISO/TS 16949 requirements. Buyers acknowledge and agree that, if they use any non-designated products in automotive applications, TI will not be responsible for any failure to meet such requirements.

Following are URLs where you can obtain information on other Texas Instruments products and application solutions:

| Products | | Applications | |
|-----------------------|--|---------------------|--|
| Amplifiers | amplifier.ti.com | Audio | www.ti.com/audio |
| Data Converters | dataconverter.ti.com | Automotive | www.ti.com/automotive |
| DSP | dsp.ti.com | Broadband | www.ti.com/broadband |
| Interface | interface.ti.com | Digital Control | www.ti.com/digitalcontrol |
| Logic | logic.ti.com | Military | www.ti.com/military |
| Power Mgmt | power.ti.com | Optical Networking | www.ti.com/opticalnetwork |
| Microcontrollers | microcontroller.ti.com | Security | www.ti.com/security |
| RFID | www.ti-rfid.com | Telephony | www.ti.com/telephony |
| Low Power Wireless | www.ti.com/lpw | Video & Imaging | www.ti.com/video |
| | | Wireless | www.ti.com/wireless |

Mailing Address: Texas Instruments, Post Office Box 655303, Dallas, Texas 75265
Copyright © 2007, Texas Instruments Incorporated